

High Power Bi-Directional Coupler

BDCN-15-25+

50Ω 15dB Coupling DC Pass 824 to 2525 MHz

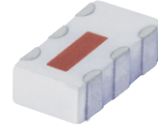

Generic photo used for illustration purposes only

CASE STYLE: FV1206-1

+RoHS Compliant
The +Suffix identifies RoHS Compliance. See our web site for RoHS Compliance methodologies and qualifications

Available Tape and Reel at no extra cost
Reel Size 7" Devices/Reel 20, 50, 100, 200, 500, 1000, 3000

Maximum Ratings

Operating Temperature	-55°C to 100°C
Storage Temperature	-55°C to 100°C
DC Current	0.5A
Permanent damage may occur if any of these limits are exceeded.	

Pin Connections

INPUT	1
OUTPUT	4
COUPLED (forward)	6
COUPLED (reverse)	3
GROUND	2,5

Product Marking: CM

Outline Drawing

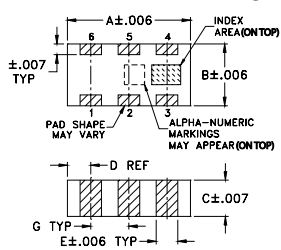

PCB Land Pattern

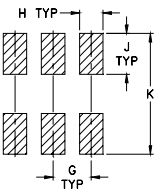

Suggested Layout, Tolerance to be within ±0.02

Outline Dimensions (inch mm)

A	B	C	D	E	F
.126	.063	.035	.024	.022	.011
3.20	1.60	0.89	0.61	0.56	0.28
G	H	J	K	wt	
.039	.024	.042	.123	grams	
0.99	0.61	1.07	3.12	.020	

Demo Board MCL P/N: TB-255+ Suggested PCB Layout (PL-131)

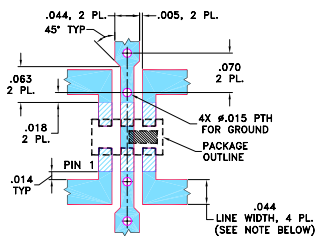

- NOTES: 1. TRACE WIDTH IS SHOWN FOR ROGERS R04350B WITH DIELECTRIC THICKNESS 0.020" ± 0.0015"; COPPER: 1/2 OZ. EACH SIDE. FOR OTHER MATERIALS TRACE WIDTH MAY NEED TO BE MODIFIED.
2. BOTTOM SIDE OF THE PCB IS CONTINUOUS GROUND PLANE.
3. DENOTES PCB COPPER LAYOUT WITH SMOBC (SOLDER MASK OVER BARE COPPER)
4. DENOTES COPPER LAND PATTERN FREE OF SOLDER MASK

Notes

- A. Performance and quality attributes and conditions not expressly stated in this specification document are intended to be excluded and do not form a part of this specification document.
B. Electrical specifications and performance data contained in this specification document are based on Mini-Circuits' applicable established test performance criteria and measurement instructions.
C. The parts covered by this specification document are subject to Mini-Circuits' standard limited warranty and terms and conditions (collectively, "Standard Terms"); Purchasers of this part are entitled to the rights and benefits contained therein. For a full statement of the Standard Terms and the exclusive rights and remedies thereunder, please visit Mini-Circuits' website at www.minicircuits.com/MCLStore/terms.jsp

Features

- four-port coupler
- wideband, 824 to 2525 MHz
- excellent VSWR, 1.2:1 typ., all ports
- ultra small size, hermetically sealed
- minimal variation with temperature variation
- protected by US Patent 7,049,905
- DC Current through input to output 0.5A Max. at 1.0 watt RF input.

Applications

- UMTS
- PCS
- GPS
- TDMA
- CDMA
- ISM
- DCS

Electrical Specifications

FREQUENCY (MHz)	COUPLING (dB)		MAINLINE LOSS ¹ (dB)		DIRECTIVITY (dB)		VSWR (:1)	POWER INPUT ² (W)	
	Nom.	Max. Flatness	Typ.	Max.	Typ.	Min.		Typ.	Max.
f _c -f _u									
824-2525	14.5±2.0	±3.0	0.6	1.0	13	8	1.2		16
824-894	15.0±0.6	±0.6	0.4	0.8	12	8	1.2		16
880-960	14.5±0.6	±0.6	0.5	0.9	13	8	1.2		16
1710-1880	12.5±0.6	±0.4	0.6	0.9	22	16	1.2		16
1850-1990	12.6±0.6	±0.4	0.5	0.9	22	16	1.2		16
2110-2170	13.3±0.6	±0.5	0.6	1.0	22	16	1.2		16
2375-2525	15.5±0.6	±1.5	0.6	1.0	12	8	1.2		16

1. Includes theoretical power loss of 0.14 dB at 15 dB coupling.

2. Derate linearly 8W at 100°C

Typical Performance Data

Frequency (MHz)	Mainline Loss (dB)		Coupling (dB)		Directivity (dB)		Return Loss (dB)		
	In-Out	In-Cpl Fwd	Out-Cpl Rev	Out-Cpl Fwd	In-Cpl Rev	In	Out	Cpl Fwd	Cpl Rev
824	0.37	15.28	15.27	11.53	11.52	26.01	27.03	25.99	25.58
1000	0.44	14.11	14.11	12.25	12.24	25.11	25.83	24.37	24.79
1500	0.59	12.54	12.55	16.08	16.10	24.39	23.75	23.65	24.79
1700	0.61	12.47	12.47	19.01	19.05	25.23	23.52	24.34	26.21
1840	0.62	12.61	12.61	22.34	22.42	25.17	24.04	25.02	26.08
1990	0.62	12.94	12.93	29.95	29.96	25.23	24.26	26.32	26.52
2070	0.62	13.21	13.20	45.18	45.15	25.18	24.44	26.72	26.51
2170	0.60	13.65	13.63	29.61	29.91	25.36	25.28	27.35	27.20
2350	0.58	14.78	14.74	18.39	18.50	25.16	25.93	28.29	26.93
2525	0.55	16.45	16.40	12.11	12.23	24.12	25.98	28.45	25.25

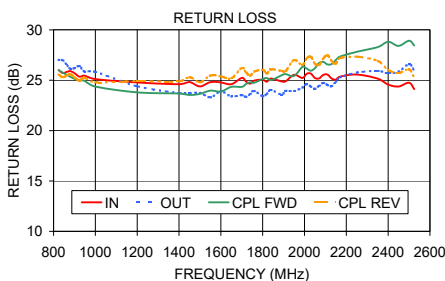
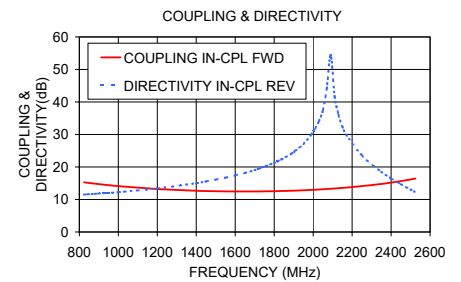
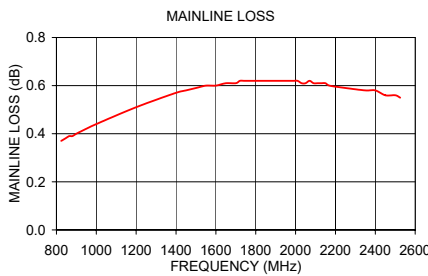

Electrical Schematic

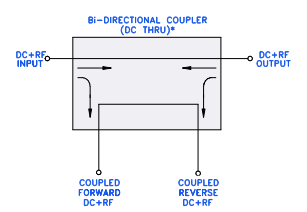

* ELECTRICAL SCHEMATIC IS FOR BI-DIRECTIONAL COUPLER WITHOUT INTERNAL TRANSFORMERS AND RESISTORS.



Bi-Directional Coupler

BDCN-15-25+

Typical Performance Data

FREQUENCY (MHz)	INSERTION LOSS (dB)	COUPLING (dB)		DIRECTIVITY (dB)		RETURN LOSS (dB)			TERM (dB)
		IN	OUT	IN	OUT	IN	OUT	CPL	
824.0	0.37	15.28	15.27	11.52	11.53	26.01	27.03	25.99	25.58
844.0	0.38	15.12	15.12	11.60	11.60	25.72	26.97	25.76	25.29
864.0	0.39	14.98	14.97	11.67	11.68	25.84	26.50	25.52	25.49
880.0	0.39	14.86	14.85	11.74	11.75	25.91	26.15	25.35	25.60
900.0	0.40	14.72	14.71	11.82	11.82	25.70	26.20	25.14	25.31
924.0	0.41	14.56	14.56	11.91	11.92	25.35	26.41	25.00	24.97
948.0	0.42	14.42	14.41	12.00	12.01	25.46	25.87	24.94	25.25
1000.0	0.44	14.11	14.11	12.24	12.25	25.11	25.83	24.37	24.79
1200.0	0.51	13.22	13.22	13.39	13.41	24.78	24.40	23.80	24.91
1400.0	0.57	12.68	12.69	15.02	15.02	24.61	23.73	23.68	24.90
1450.0	0.58	12.60	12.61	15.53	15.53	24.82	23.73	23.54	25.31
1500.0	0.59	12.54	12.55	16.10	16.08	24.39	23.75	23.65	24.79
1550.0	0.60	12.49	12.49	16.70	16.70	24.81	23.30	23.97	25.47
1600.0	0.60	12.47	12.47	17.42	17.39	24.78	23.89	23.88	25.38
1650.0	0.61	12.46	12.46	18.16	18.12	24.61	23.40	24.34	25.19
1700.0	0.61	12.47	12.47	19.05	19.01	25.23	23.52	24.34	26.21
1720.0	0.62	12.48	12.48	19.45	19.41	24.88	23.34	24.62	25.79
1740.0	0.62	12.49	12.50	19.89	19.83	24.66	23.63	24.80	25.46
1760.0	0.62	12.51	12.51	20.32	20.27	24.97	23.93	24.76	25.86
1800.0	0.62	12.55	12.55	21.27	21.23	25.05	23.41	25.12	26.03
1820.0	0.62	12.58	12.58	21.83	21.77	24.86	23.65	25.22	25.68
1840.0	0.62	12.61	12.61	22.42	22.34	25.17	24.04	25.02	26.08
1890.0	0.62	12.69	12.69	24.14	24.08	24.88	23.56	25.49	25.94
1910.0	0.62	12.74	12.73	25.04	24.96	24.90	23.95	25.61	25.91
1950.0	0.62	12.83	12.82	27.03	26.99	25.54	23.92	25.43	26.99
1990.0	0.62	12.94	12.93	29.96	29.95	25.23	24.26	26.32	26.52
2010.0	0.62	13.00	12.99	31.81	31.91	25.63	24.61	26.17	27.16
2030.0	0.61	13.07	13.05	34.14	34.36	25.66	24.38	25.95	27.33
2050.0	0.61	13.14	13.12	37.46	37.95	25.22	24.14	26.21	26.64
2070.0	0.62	13.21	13.20	44.15	45.18	25.18	24.44	26.72	26.51
2090.0	0.61	13.29	13.27	54.32	57.06	25.53	24.75	26.82	27.16
2110.0	0.61	13.37	13.35	41.73	41.27	25.56	24.53	26.57	27.47
2130.0	0.61	13.46	13.44	36.00	35.55	25.17	24.40	26.61	26.89
2150.0	0.61	13.56	13.53	32.41	32.03	25.06	24.85	27.01	26.65
2170.0	0.60	13.65	13.63	29.91	29.61	25.36	25.28	27.35	27.20
2250.0	0.59	14.10	14.06	23.53	23.36	25.57	25.76	27.82	27.34
2350.0	0.58	14.78	14.74	18.50	18.39	25.16	25.93	28.29	26.93
2400.0	0.58	15.20	15.15	16.48	16.37	24.57	25.69	28.82	26.02
2450.0	0.56	15.65	15.61	14.71	14.61	24.38	25.85	28.41	25.72
2500.0	0.56	16.16	16.11	13.05	12.93	24.76	26.59	28.92	26.08
2525.0	0.55	16.45	16.40	12.23	12.11	24.12	25.98	28.45	25.25



P.O. Box 350166, Brooklyn, New York 11235-0003 (718) 934-4500 Fax (718) 332-4661 www.minicircuits.com The Design Engineers Search Engine www.minicircuits.com Provides ACTUAL Data Instantly at [minicircuits.com](http://www.minicircuits.com)

For detailed performance specs & shopping online see web site

Notes: 1. Performance and quality attributes and conditions not expressly stated in this specification sheet are intended to be excluded and do not form a part of this specification sheet. 2. Electrical specifications and performance data contained herein are based on Mini-Circuits' applicable established test performance criteria and measurement instructions. 3. The parts covered by this specification sheet are subject to Mini-Circuits standard limited warranty and terms and conditions (collectively, "Standard Terms"); Purchasers of this part are entitled to the rights and benefits contained therein. For a full statement of the Standard Terms and the exclusive rights and remedies thereunder, please visit Mini-Circuits' website at www.minicircuits.com/MCLStore/terms.jsp.

REV. OR
BDCN-15-25+
120520
Page 1 of 1

Bi-Directional Coupler

BDCN-15-25+

Typical Performance Curves

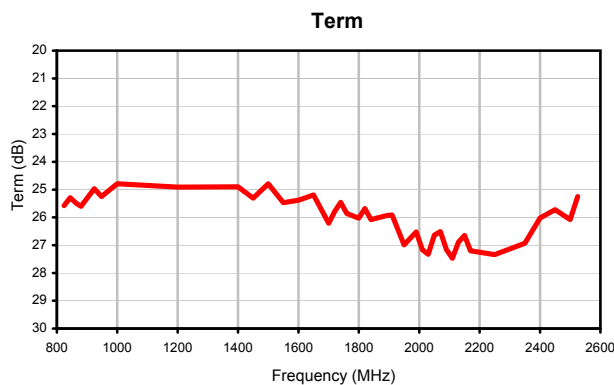
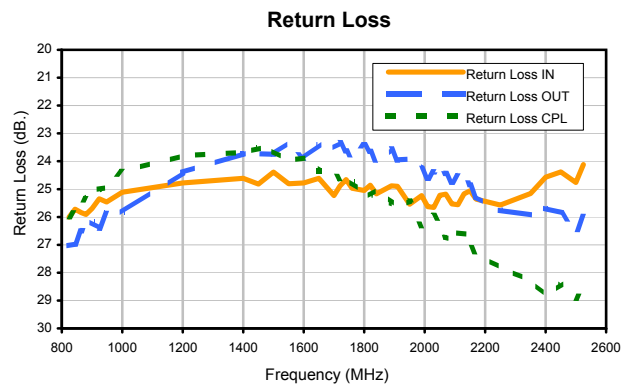
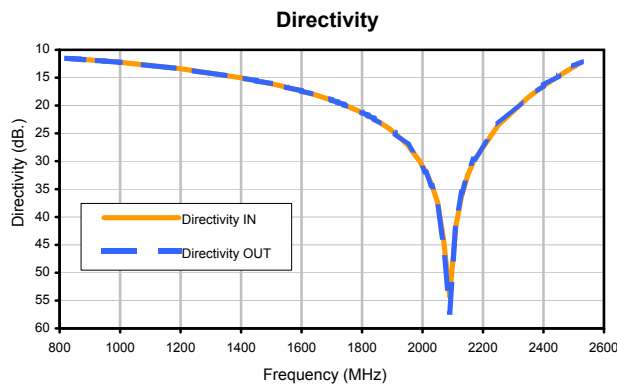
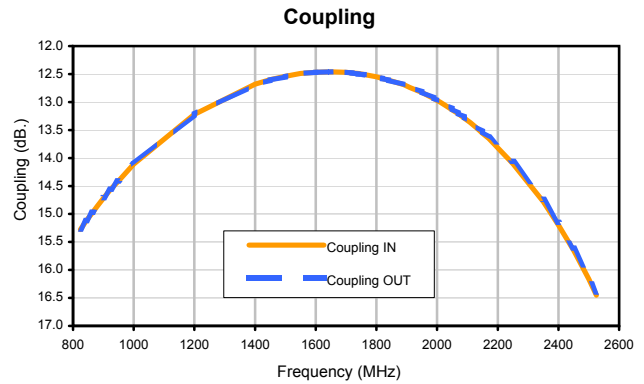

P.O. Box 350166, Brooklyn, New York 11235-0003 (718) 934-4500 Fax (718) 332-4661 The Design Engineers Search Engine Provides ACTUAL Data Instantly at minicircuits.com

For detailed performance specs & shopping online see web site

Notes: 1. Performance and quality attributes and conditions not expressly stated in this specification sheet are intended to be excluded and do not form a part of this specification sheet. 2. Electrical specifications and performance data contained herein are based on Mini-Circuits' applicable established test performance criteria and measurement instructions. 3. The parts covered by this specification sheet are subject to Mini-Circuits' standard limited warranty and terms and conditions (collectively, "Standard Terms"); Purchasers of this part are entitled to the rights and benefits contained therein. For a full statement of the Standard Terms and the exclusive rights and remedies thereunder, please visit Mini-Circuits' website at www.minicircuits.com/MCLStore/terms.jsp.

REV. OR
BDCN-15-25+
120520
Page 1 of 1

Outline Dimensions

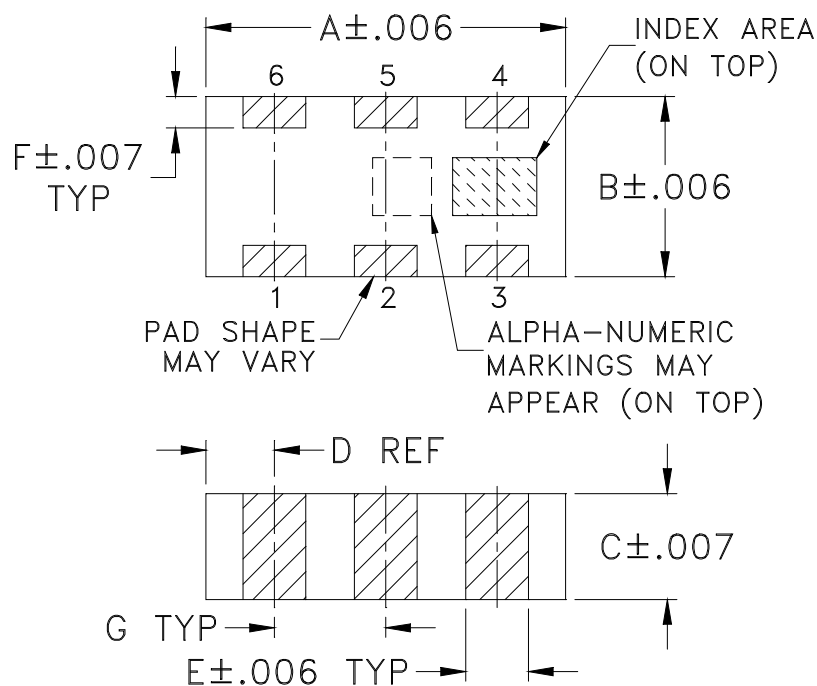

PCB Land Pattern

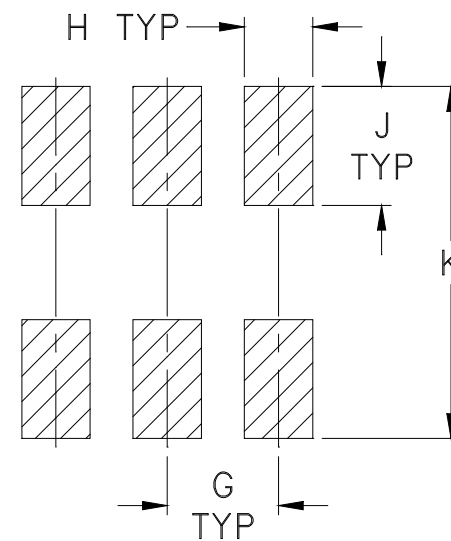

Suggested Layout,
Tolerance to be within $\pm.002$

CASE #	A	B	C	D	E	F	G	H	J	K	L	M	N	P	WT. GRAM
FV1206-1	.126 (3.20)	.063 (1.60)	.035 (0.89)	.024 (0.61)	.022 (0.56)	.011 (0.28)	.039 (0.99)	.024 (0.61)	.042 (1.07)	.123 (3.12)	--	--	--	--	.020

Dimensions are in inches (mm). Tolerances: 2 Pl. $\pm.01$; 3 Pl. $\pm.005$

Notes:

- Open style, ceramic base.
- Termination finish: **as shown below or indicated on Data Sheet.**
For RoHS Case Styles: Tin plate over Nickel plate. All models, (+) suffix.
For RoHS-5 Case Styles: Tin-Lead plate. All models, no (+) suffix.



P.O. Box 350166, Brooklyn, New York 11235-0003 (718) 934-4500 Fax (718) 332-4661 For detailed performance specs & shopping online see Mini-Circuits web site



The Design Engineers Search Engine Provides ACTUAL Data Instantly From MINI-CIRCUITS At: www.minicircuits.com

RF/IF MICROWAVE COMPONENTS

DEVICE ORIENTATION IN T&R

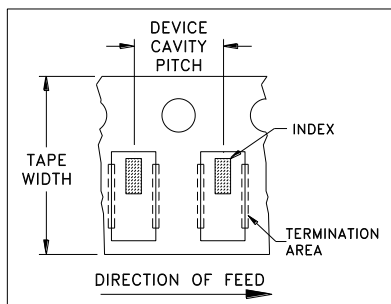

ILLUSTRATION 1

Applicable Case Styles

FV1206-1
FV1206-3

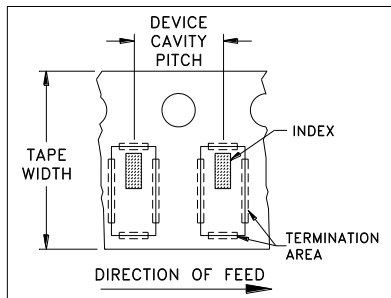

ILLUSTRATION 2

Applicable Case Styles

FV1206-4
FV1206-5
FV1206-6
FV1206-7
FV1206-9

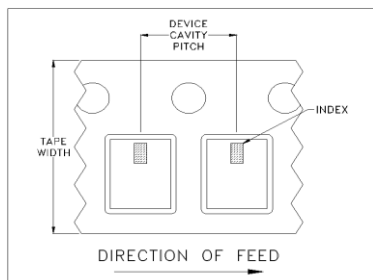

ILLUSTRATION 3

Applicable Case Styles

FV1206-12
GE0805C-18
NL1008C-6
NL1008C-7
NL1008C-9
NL1008C-10

Tape Width, mm	Device Cavity Pitch, mm	Reel Size, inches	Devices per Reel	
8	4	7	Small quantity standards (see note)	20
				50
				100
				200
				500
			1000	
			Standard	3000

Note: Please consult individual model data sheet to determine device per reel availability.

Mini-Circuits carrier tape materials provide protection from ESD (Electro-Static Discharge) during handling and transportation. Tapes are static dissipative and comply with industry standards EIA-481/EIA-541.

Go to: www.minicircuits.com/pages/pdfs/tape.pdf

Mini-Circuits ISO 9001 & ISO 14001 Certified

Mini-Circuits[®]

INTERNET <http://www.minicircuits.com>

P.O. Box 350166, Brooklyn, New York 11235-0003 (718) 934-4500 Fax (718) 332-4661

Distribution Centers NORTH AMERICA 800-654-7949 • 417-335-5935 • Fax 417-335-5945 • EUROPE 44-1252-832600 • Fax 44-1252-837010

Mini-Circuits ISO 9001 & ISO 14001 Certified

THIRD ANGLE PROJECTION

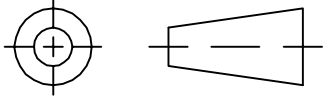

REVISIONS

REV	ECN No.	DESCRIPTION	DATE	DR	AUTH
OR	M87001	NEW RELEASE	05/20/03	MMG	ABD
A	M87231	CORRECTED DWG.	05/28/03	MMG	ABD
B	M91636	ADDED "pn" PIN CONNECTION	04/07/04	AV	ABD
C	M102713	ADDED "...WITH SMOBC"	01/16/06	GF	IL

SUGGESTED MOUNTING CONFIGURATION
FOR FV1206-1 CASE STYLE, "pb/pn" PIN CONNECTIONS

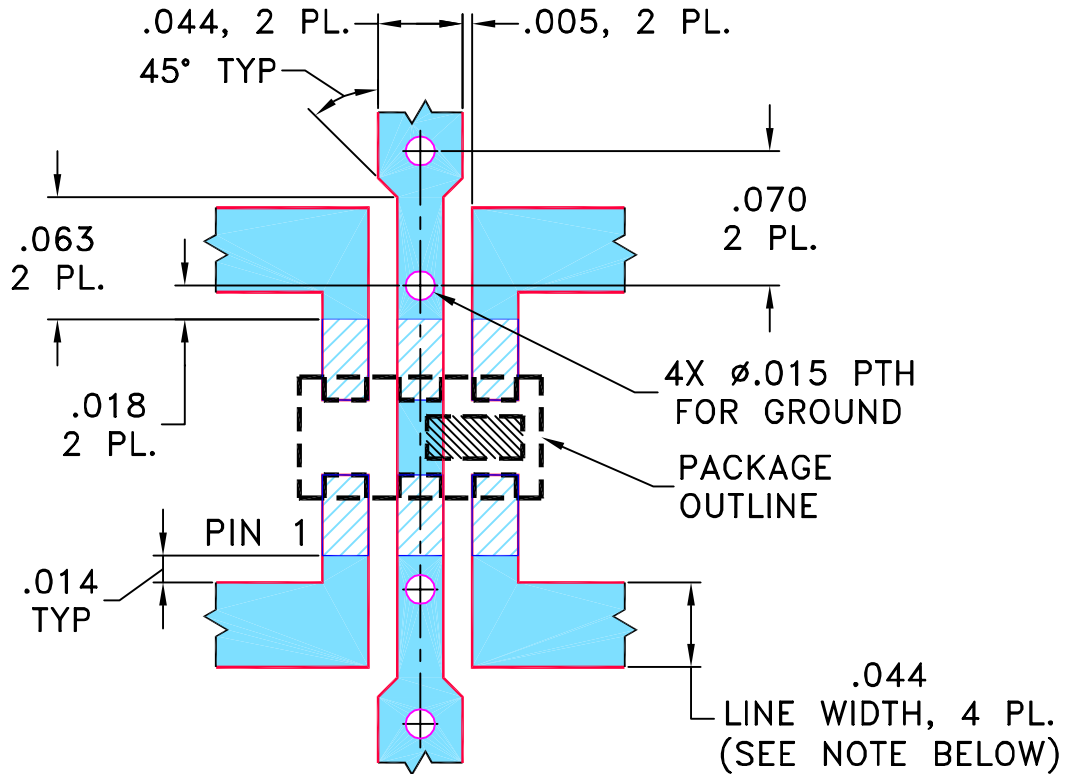

NOTES: 1. TRACE WIDTH IS SHOWN FOR ROGERS RO4350B WITH DIELECTRIC THICKNESS 0.020" ± 0.0015"; COPPER: 1/2 OZ. EACH SIDE. FOR OTHER MATERIALS TRACE WIDTH MAY NEED TO BE MODIFIED.

2. BOTTOM SIDE OF THE PCB IS CONTINUOUS GROUND PLANE.



DENOTES PCB COPPER LAYOUT WITH SMOBC (SOLDER MASK OVER BARE COPPER)

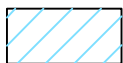

DENOTES COPPER LAND PATTERN FREE OF SOLDER MASK

UNLESS OTHERWISE SPECIFIED	INITIALS	DATE
DIMENSIONS ARE IN INCHES TOLERANCES ON: 2 PL DECIMALS ± 3 PL DECIMALS ± .005 ANGLES ± FRACTIONS ±	DRAWN	MMG 05/14/03
	CHECKED	AV 05/19/03
	APPROVED	ABD 05/20/03



Mini-Circuits®

13 Neptune Avenue
Brooklyn NY 11235

PL, pb/pn, FV1206-1, QCN/BDCN, TB-255

Mini-Circuits®
 THIS DOCUMENT AND ITS CONTENTS ARE THE PROPERTY OF MINI-CIRCUITS. EXCEPT FOR USE EXPRESSLY GRANTED, IN WRITING, TO ITS VENDORS, VENDEE AND THE UNITED STATES GOVERNMENT, MINI-CIRCUITS RESERVES ALL PROPRIETARY DESIGN, USE, MANUFACTURING AND REPRODUCTION RIGHTS THERETO. THESE CONTENTS SHALL NOT BE USED, DUPLICATED OR DISCLOSED TO ANY OUTSIDE PARTY, IN WHOLE OR IN PART, WITHOUT WRITTEN PERMISSION OF MINI-CIRCUITS.

SIZE A	CODE IDENT 15542	DRAWING NO: 98-PL-131	REV: C
FILE: 98PL131	SCALE: 10:1	SHEET: 1 OF 1	

Evaluation Board and Circuit

For Pin Connections refer to Data Sheet of the DUT

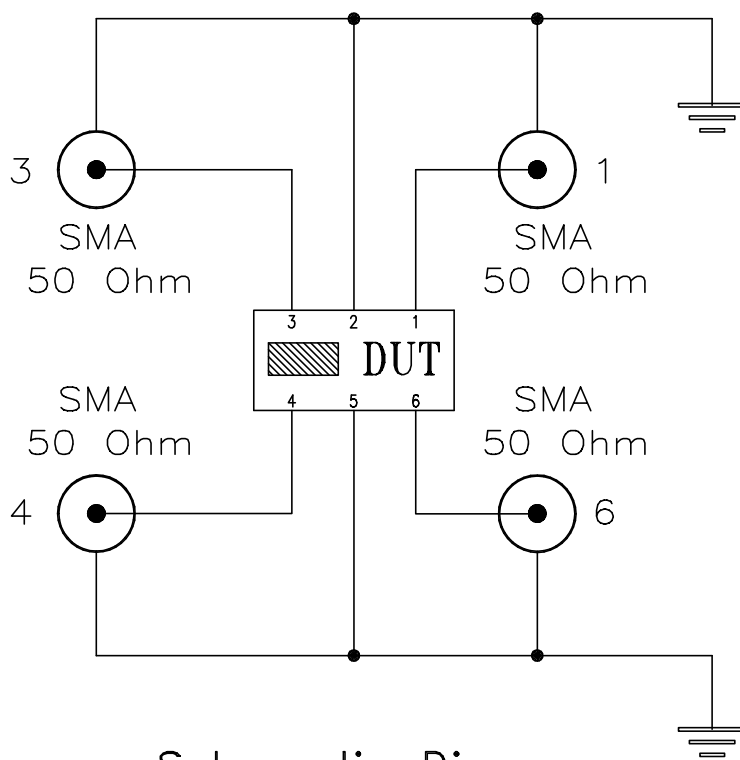
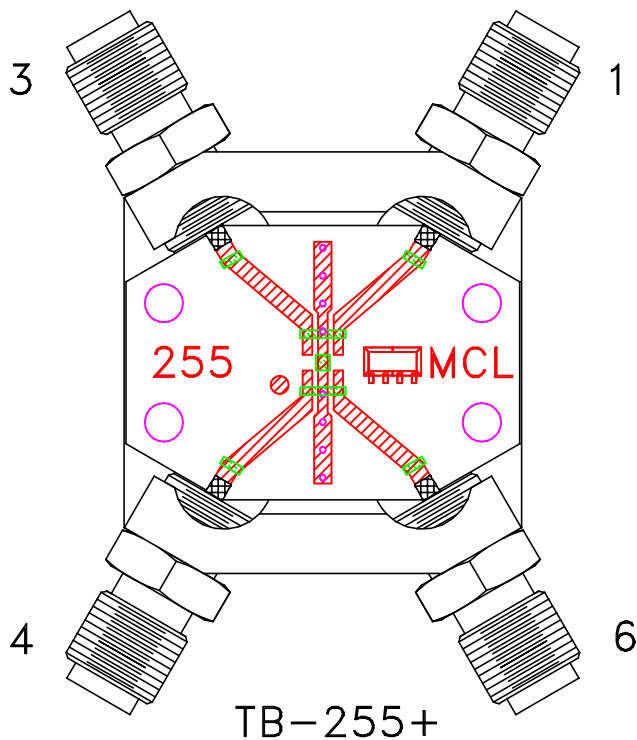

Schematic Diagram

Notes:

1. SMA Female connectors.
2. PCB Material: Rogers R04350 or equivalent, Dielectric Constant=3.5, Thickness=.020 inch.

 **Mini-Circuits®**

All Mini-Circuits products are manufactured under exacting quality assurance and control standards, and are capable of meeting published specifications after being subjected to any or all of the following physical and environmental test.

Specification	Test/Inspection Condition	Reference/Spec
Operating Temperature	-55° to 100°C Ambient Environment	Individual Model Data Sheet
Storage Temperature	-55° to 100° C Ambient Environment	Individual Model Data Sheet
Humidity	90 to 95% RH, 240 hours, 50°C	MIL-STD-202, Method 103, Condition A, Except 50°C and end-point electrical test done within 12 hours
Solder Reflow Heat	Sn-Pb Eutetic Process: 225°C peak Pb-Free Process 245° - 250°C peak	J-STD-020, Table 4-1, 4-2 and 5-2, Figure 5-1
Solderability	10X Magnification	J-STD-002, Para 4.2.5, Test S, 95% Coverage
Vibration (High Frequency)	20g peak, 10-2000 Hz, 12 times in each of three perpendicular directions (total 36)	MIL-STD-202, Method 204, Condition D
Mechanical Shock	50g, 11 ms, 1/2-sine, 18 shocks: 3 each direction, each of 3 axes	MIL-STD-202, Method 213, Condition A