

LTCC

# Bandpass Filter & Balun

50Ω 2400 to 2500 MHz

**BFGE1-252R+**



Generic photo used for illustration purposes only  
CASE STYLE: GE0805C-2

**+RoHS Compliant**

The +Suffix identifies RoHS Compliance. See our web site for RoHS Compliance methodologies and qualifications

## Features

- Low amplitude unbalance 0.3 dB typ.
- Small size (0.079"x0.049"x0.037")
- Temperature stable
- Hermetically sealed

## Applications

- ISM Band
- Bluetooth
- Zigbee
- WiFi / WLAN

### Simplified Schematic

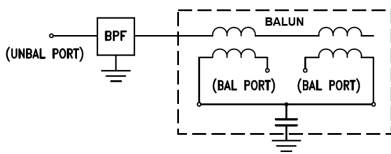

### Top View

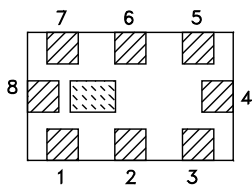

### Pad Connections

Unbalanced Port	1
Balanced Port	5, 7
GND	4, 6, 8
NC	3
NC or DC Feed	2

## Electrical Specifications at 25°C

Parameter	F#	Frequency (MHz)	Min.	Typ.	Max.	Unit
<b>Impedance Ratio</b>			1			
<b>Pass Band</b>	Insertion Loss <sup>1</sup>	F1-F2	2400 - 2500	—	1.9	2.3 dB
	Return Loss	F1-F2	2400 - 2500	9.5	25	— dB
<b>Stop Band, Lower</b>	Rejection		DC - 1000	35	44	— dB
			1000 - 2000	31	39	— dB
<b>Stop Band, Upper</b>	Rejection		4800 - 5000	34	49	— dB
			7200 - 7500	23	34	— dB
<b>Amplitude Unbalance</b>		2400 - 2500	—	0.3	1.5	dB
<b>Phase Unbalance</b>		2400 - 2500	—	1.5	10	degree

1. Tested on Evaluation Board TB-1034+

### Maximum Ratings

Operating Temperature	-40°C to +85°C
Storage Temperature*	-40°C to +85°C
RF Power Input**	1W @25°C

\* Refer to product storage temperature after installation  
Suggestion for T&R unused product storage condition: +5 ~ +35 °C,  
Humidity 45-75%RH, 12 month Max  
\*\*Derate linearly to 0.5W at 85°C.

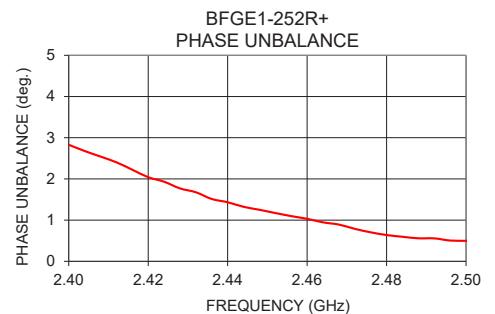
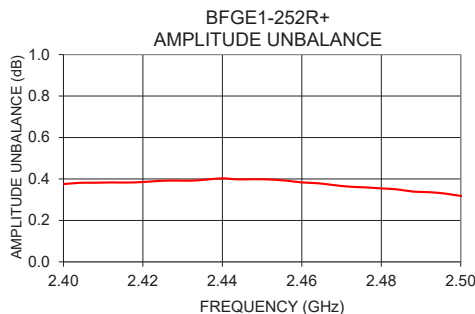
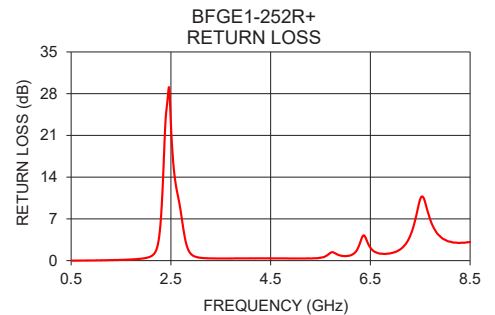
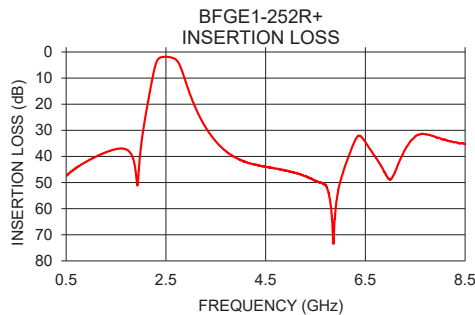

### Typical Performance Data

Frequency (GHz)	Insertion Loss (dB)	Return Loss (dB)	Amplitude Unbalance (dB)	Phase Unbalance (Deg.)
0.50	47.45	0.01	5.69	156.12
0.70	44.41	0.01	5.95	161.63
1.00	41.01	0.04	6.31	165.18
1.50	37.18	0.13	6.50	167.44
2.00	36.33	0.45	3.63	156.15
2.40	2.05	24.38	0.38	2.83
2.45	1.87	28.71	0.40	1.17
2.50	1.83	22.94	0.32	0.50
3.50	34.20	0.35	3.82	175.71
4.80	45.05	0.37	1.36	179.32
4.90	45.38	0.37	1.36	179.13
5.00	45.90	0.36	1.35	178.90
5.90	60.87	0.85	0.25	177.26
7.20	41.18	2.70	0.24	174.36
7.50	32.30	10.33	0.14	174.80
8.50	35.24	3.11	0.42	175.67

### Outline Drawing

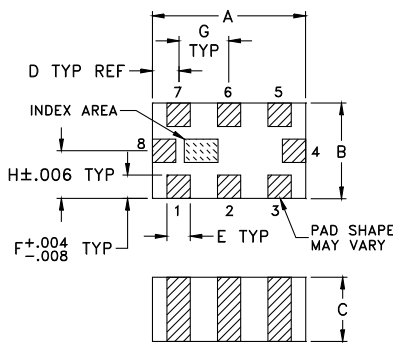

### PCB Land Pattern

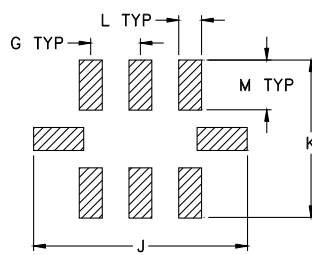

Suggested Layout,  
Tolerance to be within .002

### Demo Board MCL P/N: TB-1034+ Suggested PCB Layout (PL-551)

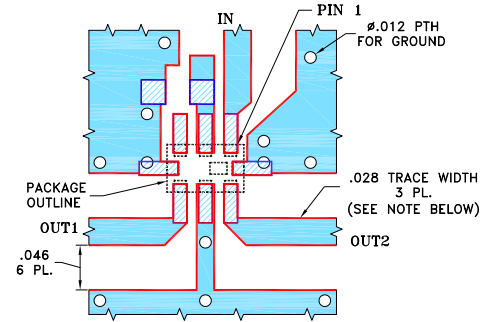

#### NOTES:

- TRACE WIDTH IS SHOWN FOR FR4, GRADE IT-180TC (ITEQ CORP.) WITH DIELECTRIC THICKNESS .016±.0015. COPPER: 1/2 OZ. EACH SIDE. FOR OTHER MATERIALS TRACE WIDTH & GAP MAY NEED TO BE MODIFIED.
  - BOTTOM SIDE OF THE PCB IS CONTINUOUS GROUND PLANE.
- DENOTES PCB COPPER LAYOUT WITH SMOBC (SOLDER MASK OVER BARE COPPER).
  - DENOTES COPPER LAND PATTERN FREE OF SOLDER MASK.

### Outline Dimensions (inch/mm)

A	B	C	D	E	F	G
.079	.049	.037	.014	.012	.012	.026
2.01	1.24	0.94	0.36	0.30	0.30	0.66
H	J	K	L	M	wt	
.025	.134	.104	0.014	.039	grams	
0.64	3.40	2.64	0.36	0.99	.008	

### Additional Notes

- Performance and quality attributes and conditions not expressly stated in this specification document are intended to be excluded and do not form a part of this specification document.
- Electrical specifications and performance data contained in this specification document are based on Mini-Circuits' applicable established test performance criteria and measurement instructions.
- The parts covered by this specification document are subject to Mini-Circuits' standard limited warranty and terms and conditions (collectively, "Standard Terms"); Purchasers of this part are entitled to the rights and benefits contained therein. For a full statement of the Standard Terms and the exclusive rights and remedies thereunder, please visit Mini-Circuits' website at [www.minicircuits.com/MCLStore/terms.jsp](http://www.minicircuits.com/MCLStore/terms.jsp)

*Typical Performance Data*

FREQUENCY (MHz)	INSERTION LOSS (dB)	RETURN LOSS (dB)	AMPLITUDE UNBAL (dB)	PHASE UNBAL <sup>(1)</sup> (Deg)
500	47.45	0.01	5.69	156.12
600	45.76	0.01	5.85	159.31
800	43.17	0.02	6.08	163.27
1000	41.01	0.04	6.31	165.18
1200	39.15	0.06	6.45	166.29
1400	37.69	0.10	6.56	167.07
1600	36.98	0.16	6.27	167.99
1800	38.94	0.25	4.45	173.13
2000	36.33	0.45	3.63	156.15
2200	13.08	1.64	2.62	23.18
2300	4.45	7.09	0.24	8.92
2400	2.05	24.38	0.38	2.83
2420	1.96	25.96	0.39	2.04
2440	1.90	27.59	0.40	1.43
2460	1.86	29.10	0.38	1.03
2480	1.84	26.99	0.35	0.64
2500	1.83	22.94	0.32	0.50
2600	2.08	12.67	0.18	0.40
2800	6.07	3.08	0.96	0.22
3000	16.99	0.64	13.14	31.29
3200	25.59	0.40	10.18	172.09
3400	31.77	0.35	4.96	174.56
3600	36.23	0.36	3.08	176.83
4000	41.43	0.38	1.79	178.90
4100	42.15	0.38	1.69	179.20
4200	42.71	0.38	1.58	179.40
4300	43.20	0.38	1.51	179.55
4400	43.63	0.38	1.44	179.90
4500	43.93	0.38	1.41	179.88
4600	44.24	0.38	1.39	179.63
4700	44.65	0.38	1.38	179.57
4800	45.05	0.37	1.36	179.32
4900	45.38	0.37	1.36	179.13
5000	45.90	0.36	1.35	178.90
5100	46.35	0.36	1.39	178.89
5200	47.00	0.35	1.42	178.48
5300	47.52	0.37	1.50	178.14
5400	48.31	0.40	1.62	177.26
5500	49.21	0.49	1.85	174.16
5600	50.07	0.73	1.05	167.81
5700	50.92	1.31	0.11	172.66
5800	58.23	1.20	0.09	176.80
5900	60.87	0.85	0.25	177.26
6000	49.51	0.75	1.14	179.71
6100	43.32	0.88	1.12	177.78
6200	38.23	1.43	1.01	176.69
6300	33.60	3.14	0.94	176.26
6400	32.18	3.92	0.88	175.90
6500	34.41	2.18	0.82	175.58
6600	37.35	1.43	0.78	175.42
6700	40.18	1.18	0.74	175.13
6800	43.11	1.12	0.72	174.87
6900	46.39	1.21	0.74	174.20
7000	48.74	1.45	0.56	172.88
7100	45.64	1.89	0.30	173.88
7200	41.18	2.70	0.24	174.36
7300	37.22	4.18	0.21	174.46
7400	34.26	6.86	0.19	174.58
7500	32.30	10.33	0.14	174.80
7600	31.54	9.74	0.10	174.92
7700	31.50	6.92	0.05	175.01
7800	31.84	5.08	0.00	175.01
7900	32.54	4.06	0.06	175.10
8000	33.05	3.49	0.12	175.19
8100	33.54	3.17	0.17	175.35
8200	34.23	3.02	0.24	175.46
8300	34.52	2.97	0.30	175.55
8400	35.04	3.01	0.37	175.61
8500	35.24	3.11	0.42	175.67

<sup>(1)</sup> Relative to 180°



## Typical Performance Curves

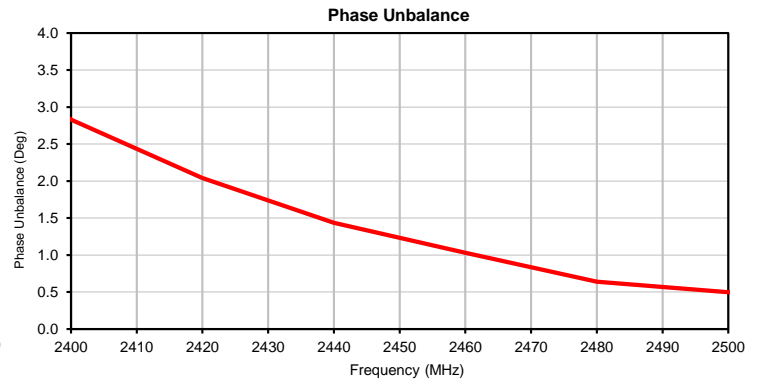
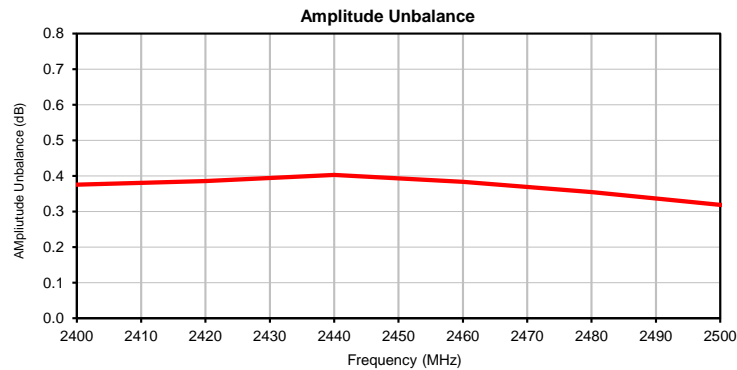
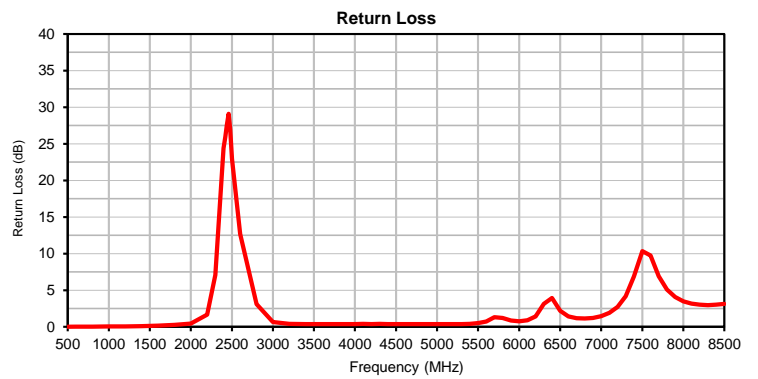
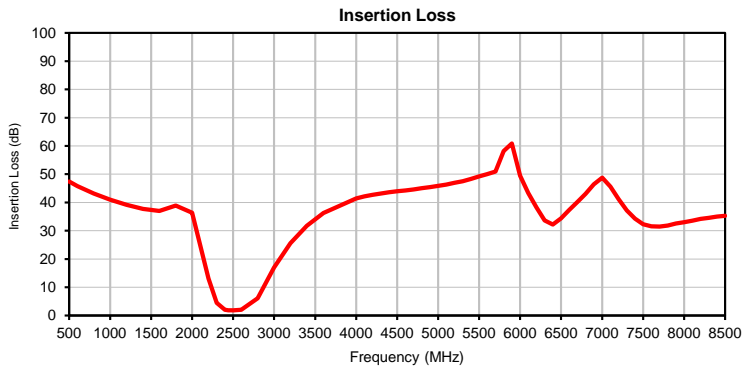

### Outline Dimensions

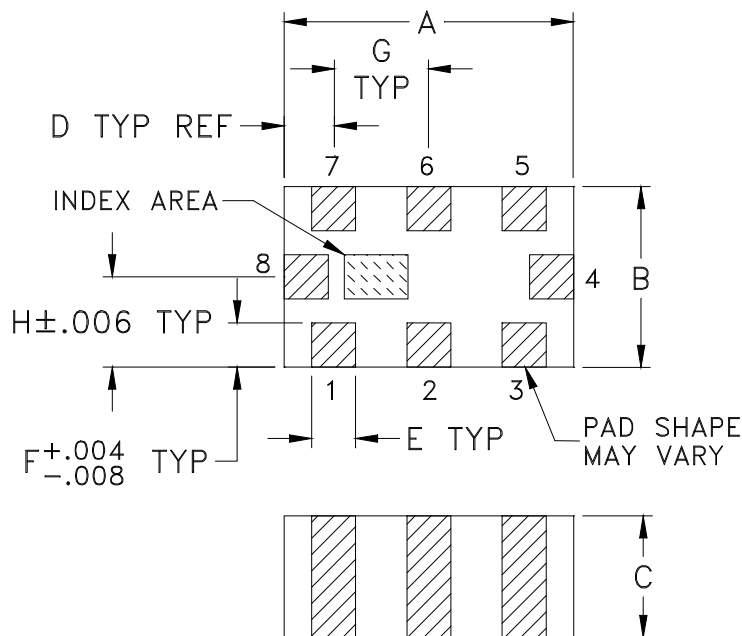

### PCB Land Pattern

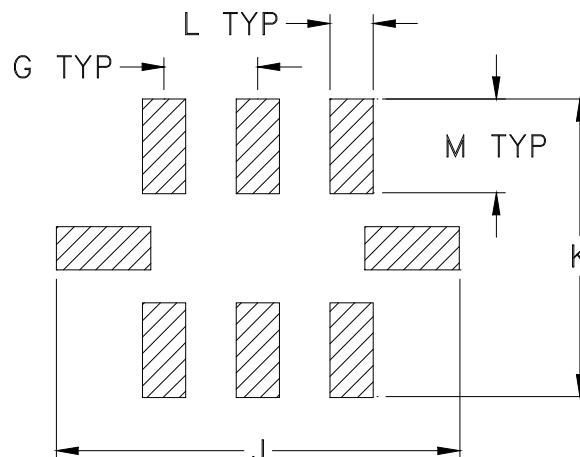

Suggested Layout,  
Tolerance to be within  $\pm .002$

CASE #	A	B	C	D	E	F	G	H	J	K	L
GE0805C-2	.079 (2.00)	.049 (1.25)	.037 (0.95)	.014 (0.35)	.012 (0.30)	.012 (0.30)	.026 (0.65)	.025 (0.63)	.134 (3.40)	.110 (2.80)	.014 (0.35)

CASE #	M	WT. GRAM
GE0805C-2	.039 (1.00)	.008

Dimensions are in inches (mm). Tolerances: 2Pl.  $\pm .01$ ; 3 Pl.  $\pm .005$

#### Notes:

- Open style, ceramic base.
- Termination finish: For RoHS Case Styles: Tin plate over Nickel plate. All models, (+) suffix.  
For RoHS-5 Case Styles: Tin-Lead plate over Nickel plate. All models, no (+) suffix.
- Pad tolerance to be non-cumulative. Minimum spacing between each pad is .004 (0.1).



P.O. Box 350166, Brooklyn, New York 11235-0003 (718) 934-4500 Fax (718) 332-4661 For detailed performance specs & shopping online see Mini-Circuits web site



The Design Engineers Search Engine Provides ACTUAL Data Instantly From MINI-CIRCUITS At: [www.minicircuits.com](http://www.minicircuits.com)

RF/IF MICROWAVE COMPONENTS

# Tape & Reel Packaging TR-F114

## DEVICE ORIENTATION IN T&R



ILLUSTRATION 1

Applicable Case Styles	
GE0805C	JC0603C
GE0805C-1	JC0603C-4
GE0805C-1AP	JC0603C-6
GE0805C-7	
GE0805C-9	
GE0805C-10	
GE0805C-11	
GE0805C-12	

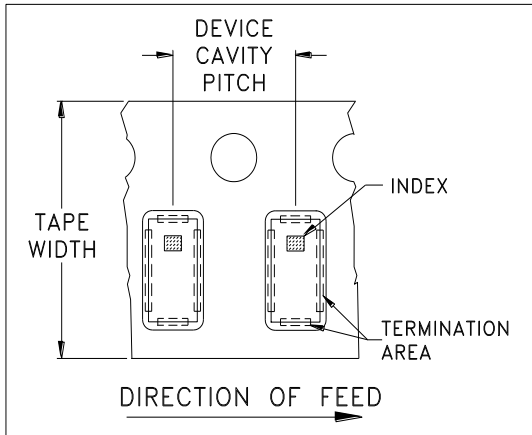

ILLUSTRATION 2

Applicable Case Styles	
GE0805C-2	JC0603C-1
GE0805C-3	JC0603C-2
GE0805C-4	JC0603C-3
GE0805C-5	JC0603C-5
GE0805C-6	JC0603C-7
GE0805C-8	
GE0805C-15	

Tape Width, mm	Device Cavity Pitch, mm	Reel Size, inches	Devices per Reel	
8	4	7	Small quantity standards (see note)	20
				50
				100
				200
				500
			Standard	1000
			Standard	4000

Note: Please Consult individual model data sheet to determine device per reel availability.

Mini-Circuits carrier tape materials provide protection from ESD (Electro-Static Discharge) during handling and transportation. Tapes are static dissipative and comply with industry standards EIA-481/EIA-541.

Go to: [www.minicircuits.com/pages/pdfs/tape.pdf](http://www.minicircuits.com/pages/pdfs/tape.pdf)



INTERNET <http://www.minicircuits.com>

P.O. Box 350166, Brooklyn, New York 11235-0003 (718) 934-4500 Fax (718) 332-4661

Distribution Centers NORTH AMERICA 800-654-7949 • 417-335-5935 • Fax 417-335-5945 • EUROPE 44-1252-832600 • Fax 44-1252-837010

Mini-Circuits ISO 9001 & ISO 14001 Certified

THIRD ANGLE PROJECTION

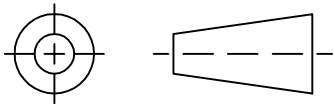

REVISIONS

REV	ECN No.	DESCRIPTION	DATE	DR	AUTH
OR	M168200	NEW RELEASE	05/31/18	NP	SL

SUGGESTED MOUNTING CONFIGURATION  
FOR GE0805C-2 CASE STYLE, "08TJ01" PIN CODE

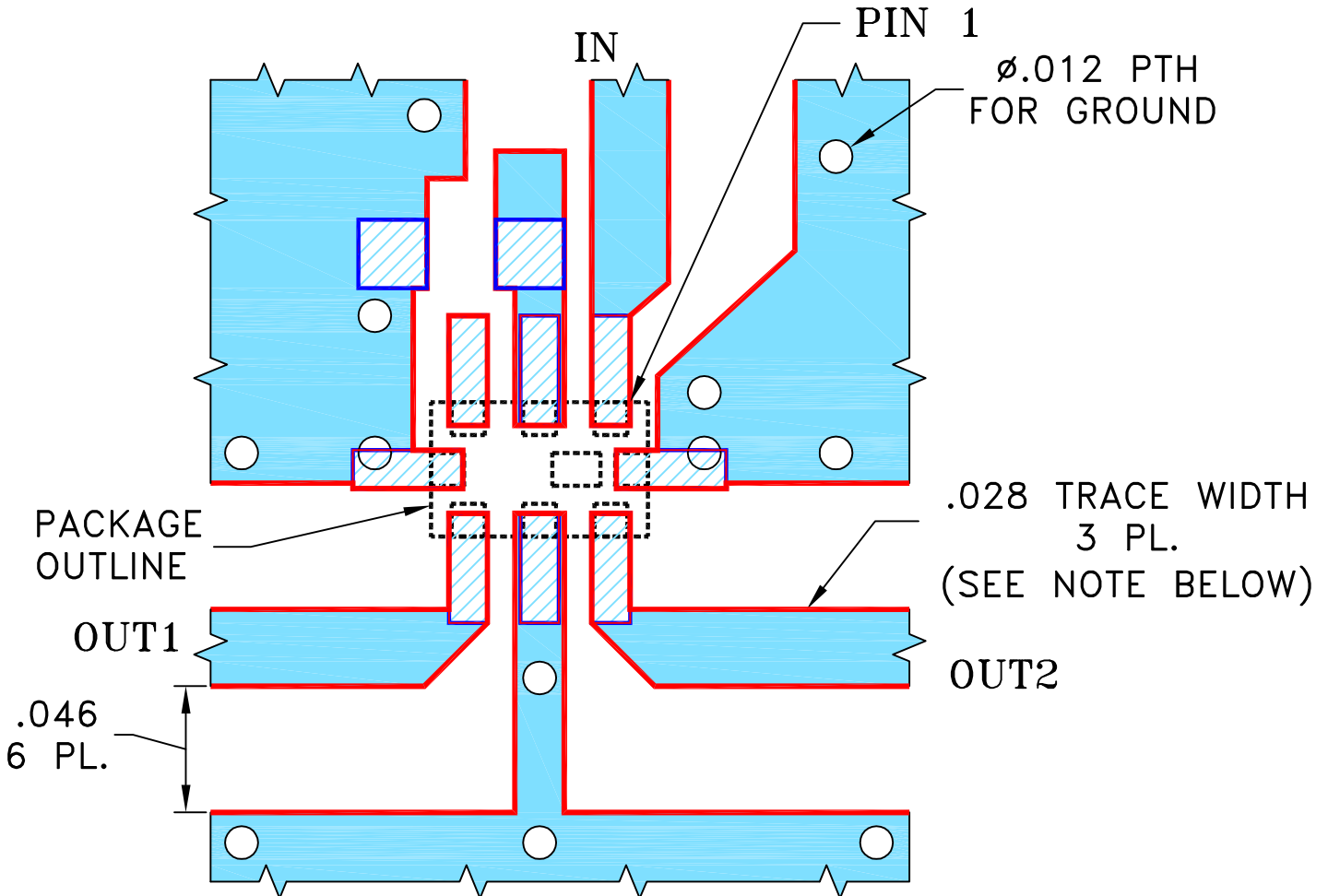

NOTES:

- TRACE WIDTH IS SHOWN FOR FR4, GRADE IT-180TC (ITEQ CORP.) WITH DIELECTRIC THICKNESS  $.016 \pm .0015$ . COPPER: 1/2 OZ. EACH SIDE. FOR OTHER MATERIALS TRACE WIDTH & GAP MAY NEED TO BE MODIFIED.
- BOTTOM SIDE OF THE PCB IS CONTINUOUS GROUND PLANE.

- DENOTES PCB COPPER LAYOUT WITH SMOBC (SOLDER MASK OVER BARE COPPER).
- DENOTES COPPER LAND PATTERN FREE OF SOLDER MASK.

UNLESS OTHERWISE SPECIFIED	INITIALS	DATE
DRAWN	NP	05/30/18
CHECKED	GF	05/30/18
APPROVED	SL	05/31/18

**Mini-Circuits®** 13 Neptune Avenue  
Brooklyn NY 11235

PL, 08TJ01, GE0805C-2, TB-1034+

Mini-Circuits®  
THIS DOCUMENT AND ITS CONTENTS ARE THE PROPERTY OF MINI-CIRCUITS. EXCEPT FOR USE EXPRESSLY GRANTED, IN WRITING, TO ITS VENDORS, VENDEE AND THE UNITED STATES GOVERNMENT, MINI-CIRCUITS RESERVES ALL PROPRIETARY DESIGN, USE, MANUFACTURING AND REPRODUCTION RIGHTS THERETO. THESE CONTENTS SHALL NOT BE USED, DUPLICATED OR DISCLOSED TO ANY OUTSIDE PARTY, IN WHOLE OR IN PART, WITHOUT WRITTEN PERMISSION OF MINI-CIRCUITS.

SIZE	CODE IDENT	DRAWING NO:	REV:
A	15542	98-PL-551	OR
FILE:	98PL551	SCALE: 15:1	SHEET: 1 OF 1

# Evaluation Board and Circuit

UNBALANCED PORT

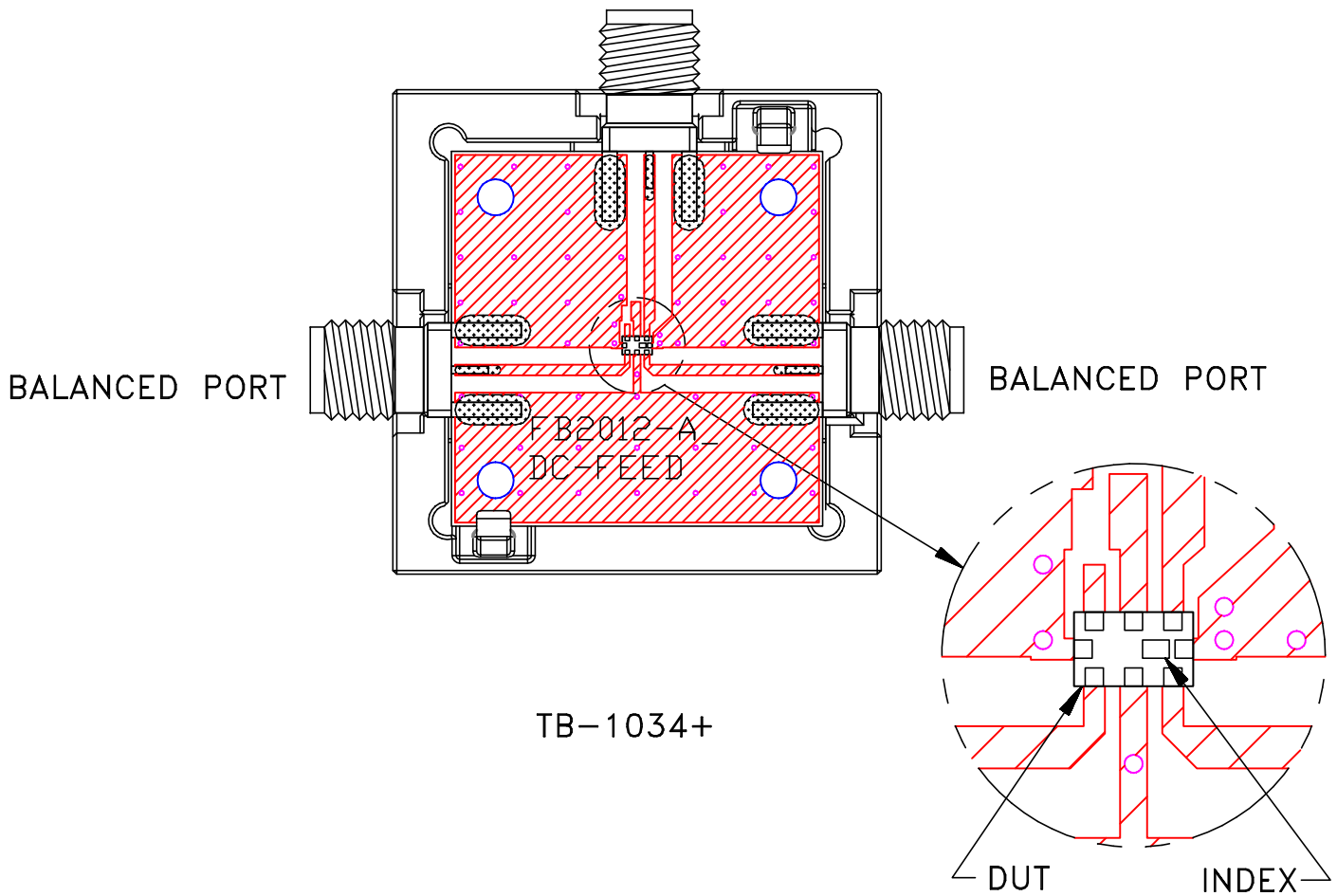

TB-1034+

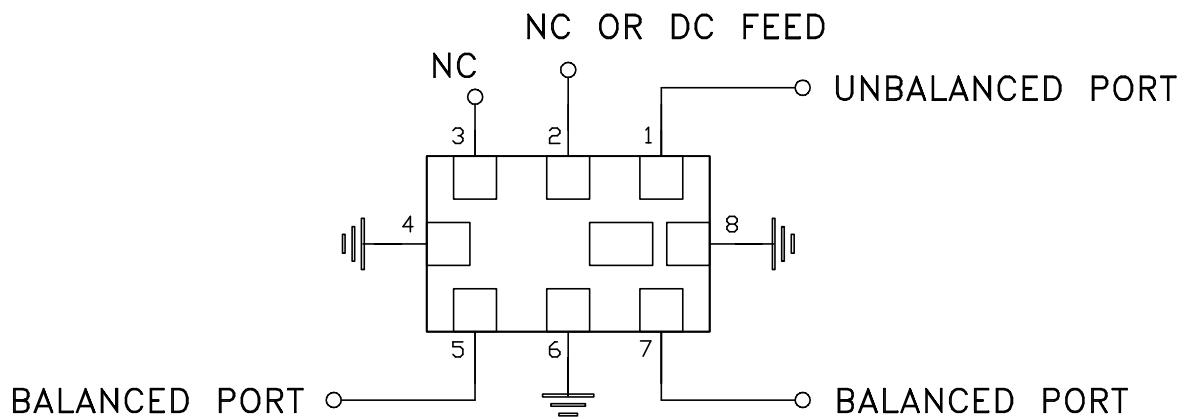

Schematic Diagram

## Notes:

1. 50 Ohm SMA Female connectors.
2. PCB Material: FR4 or equivalent,  
Dielectric Constant=4.5, Thickness=.016 inch.

 **Mini-Circuits®**



All Mini-Circuits products are manufactured under exacting quality assurance and control standards, and are capable of meeting published specifications after being subjected to any or all of the following physical and environmental test.

Specification	Test/Inspection Condition	Reference/Spec
Operating Temperature	-40° to 85° C Ambient Environment	Individual Model Data Sheet
Storage Temperature	-40° to 85° C Ambient Environment	Individual Model Data Sheet
Humidity	90 to 95% RH, 240 hours, 50°C	MIL-STD-202, Method 103, Condition A, Except 50°C and end-point electrical test done within 12 hours
Thermal Shock	-55° to 100°C, 100 cycles	MIL-STD-202, Method 107, Condition A-3, except +100°C
Solder Reflow Heat	Sn-Pb Eutectic Process: 225°C peak Pb-Free Process: 250°C peak	J-STD-020C, Table 4-1, 4-2 and 5-2; Figure 5-1
Solderability	10X Magnification	J-STD-002, Para 4.2.5, Test S, 95% Coverage
Vibration (High Frequency)	20g peak, 10-2000 Hz, 12 times in each of three perpendicular directions (total 36)	MIL-STD-202, Method 204, Condition D
Mechanical Shock	50g, 11 ms, 1/2-sine, 18 shocks: 3 each direction, each of 3 axes	MIL-STD-202, Method 213, Condition A