

# Surface Mount Bandpass Filter

## BPF-B59+

50Ω 57 to 61 MHz

### The Big Deal

- High rejection, 65dB typical
- Good VSWR, 1.6:1 typical
- Sharp insertion loss roll off
- SMT shielded case

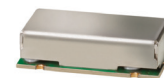

CASE STYLE: HZ1198

### Product Overview

The BPF-B59+ is a narrow-band bandpass filter in a shielded package (size of 0.472" x 0.826" x .22") fabricated using SMT technology and offers sharp shape factor. Covering 59 MHz  $\pm$  2 MHz band width, these units offer good matching within the passband and high rejection. This unit uses a miniature high Q capacitors and wire welded inductors for high reliability. In addition it has repeatable performance across production lots and consistent performance across temperature.

### Key Features

Feature	Advantages
Narrow bandwidth filter (fractional bandwidth of 7 %)	Fast roll-off; this will attenuate frequencies closer to the passband with good rejection value of > 20 dB.
Good VSWR, 1.6:1 typical in passband	The BPF-B59+ has very good return loss for a narrow bandwidth which provides good matching when used with other devices.
More than 40dB rejection up to 2200MHz	This enables the filter to attenuate spurious signals and reject harmonics for broad band of frequency.
Shielded case	Reduced interference with and from the surrounding components.

#### Notes

- A. Performance and quality attributes and conditions not expressly stated in this specification document are intended to be excluded and do not form a part of this specification document.  
B. Electrical specifications and performance data contained in this specification document are based on Mini-Circuit's applicable established test performance criteria and measurement instructions.  
C. The parts covered by this specification document are subject to Mini-Circuits standard limited warranty and terms and conditions (collectively, "Standard Terms"); Purchasers of this part are entitled to the rights and benefits contained therein. For a full statement of the Standard Terms and the exclusive rights and remedies thereunder, please visit Mini-Circuits' website at [www.minicircuits.com/MCLStore/terms.jsp](http://www.minicircuits.com/MCLStore/terms.jsp)



# Bandpass Filter

## BPF-B59+

50Ω 57 to 61 MHz

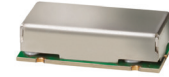

CASE STYLE: HZ1198

### Features

- Good VSWR, 1.6:1 typical in passband
- High rejection, 65 dB typical
- Sharp insertion loss roll off
- Shielded case
- Aqueous washable

### Applications

- Harmonic rejection
- Transmitters / receivers
- ILS / Localiser
- Radio communications

### Electrical Specifications at 25°C

Parameter	F#	Frequency (MHz)	Min.	Typ.	Max.	Unit	
Pass Band	Center Frequency	—	—	59	—	MHz	
	Insertion Loss	F1-F2	57-61	—	3.9	5.5	dB
	VSWR	F1-F2	57-61	—	1.6	1.9	:1
Stop Band, Lower	Insertion Loss	DC-F3	DC-52	20	33	—	dB
	VSWR	DC-F3	DC-52	—	27	—	:1
Stop Band, Upper	Insertion Loss	F4-F5	68-2600	20	32	—	dB
	VSWR	F4-F5	68-2600	—	17	—	:1

### Maximum Ratings

Operating Temperature	-40°C to 85°C
Storage Temperature	-55°C to 100°C
RF Power Input	0.08W max.

Permanent damage may occur if any of these limits are exceeded.

### Functional Schematic

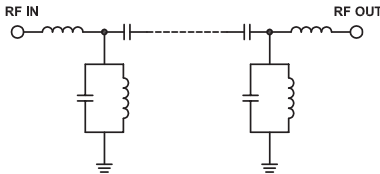

### Typical Frequency Response

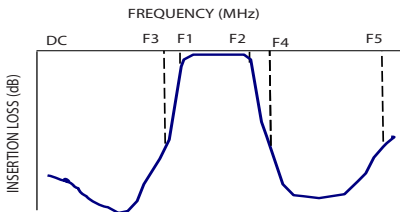

### Typical Performance Data at 25°C

Frequency (MHz)	Insertion Loss (dB)	VSWR (:1)	Frequency (MHz)	Group Delay (nsec)
0.5	84.65	11.69	57.00	175.41
15.0	78.34	17.39	57.25	171.92
49.0	49.77	86.86	57.50	166.70
52.0	34.89	48.26	57.75	160.62
53.0	28.63	31.60	58.00	154.85
54.5	17.03	11.03	58.15	152.00
55.5	8.36	3.18	58.25	150.10
56.5	4.25	1.28	58.50	146.52
57.0	3.78	1.33	58.75	144.02
59.0	3.42	1.53	58.90	143.05
61.0	3.82	1.18	59.00	142.41
62.0	5.21	1.27	59.10	142.07
63.0	10.50	3.38	59.25	141.56
64.0	17.62	6.97	59.50	141.34
68.0	37.62	22.29	59.75	142.03
72.0	49.37	36.20	60.00	143.64
100.0	85.53	91.43	60.25	146.26
500.0	80.23	434.30	60.50	149.72
1000.0	81.36	133.63	60.75	153.58
2200.0	52.21	69.49	61.00	157.15

**+RoHS Compliant**  
The +Suffix identifies RoHS Compliance. See our web site for RoHS Compliance methodologies and qualifications

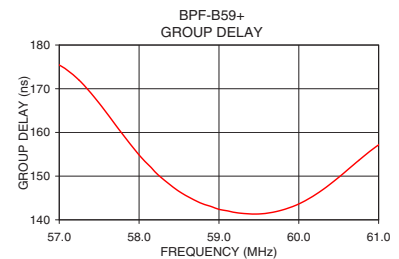
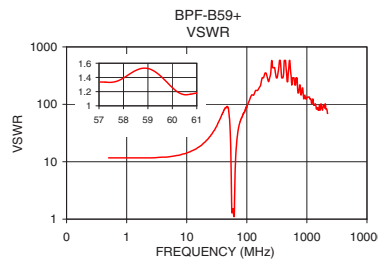
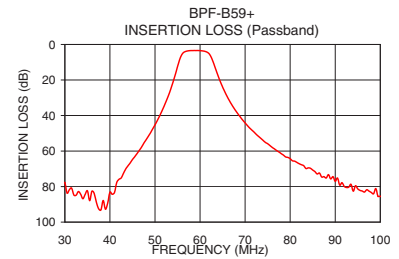
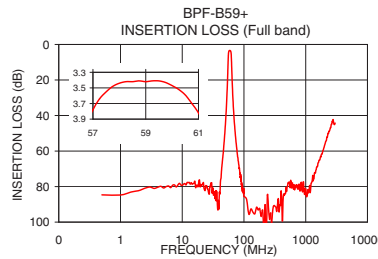

### Notes

- Performance and quality attributes and conditions not expressly stated in this specification document are intended to be excluded and do not form a part of this specification document.
- Electrical specifications and performance data contained in this specification document are based on Mini-Circuit's applicable established test performance criteria and measurement instructions.
- The parts covered by this specification document are subject to Mini-Circuits standard limited warranty and terms and conditions (collectively, "Standard Terms"); Purchasers of this part are entitled to the rights and benefits contained therein. For a full statement of the Standard Terms and the exclusive rights and remedies thereunder, please visit Mini-Circuits' website at [www.minicircuits.com/MCLStore/terms.jsp](http://www.minicircuits.com/MCLStore/terms.jsp)



## Pad Connections

INPUT	1
OUTPUT	2
GROUND	3,4,5,6

## Demo Board MCL P/N: TB-400 Suggested PCB Layout (PL-247)

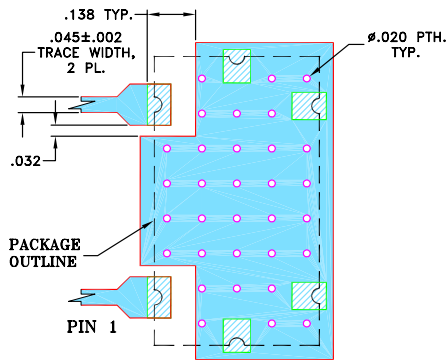

### NOTES:

- TRACE WIDTH IS SHOWN FOR FR4 WITH DIELECTRIC THICKNESS .025"±.002". COPPER: 1/2 OZ. EACH SIDE.  
FOR OTHER MATERIALS TRACE WIDTH MAY NEED TO BE MODIFIED.
- BOTTOM SIDE OF THE PCB IS CONTINUOUS GROUND PLANE.

- DENOTES PCB COPPER LAYOUT WITH SMOBC (SOLDER MASK OVER BARE COPPER)
- DENOTES COPPER LAND PATTERN FREE OF SOLDERMASK

## Outline Drawing

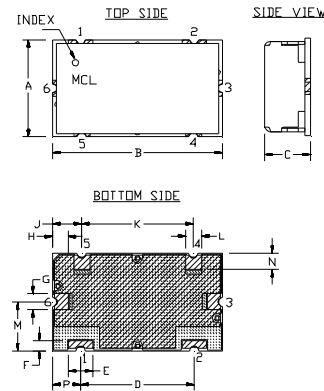

## PCB Land Pattern

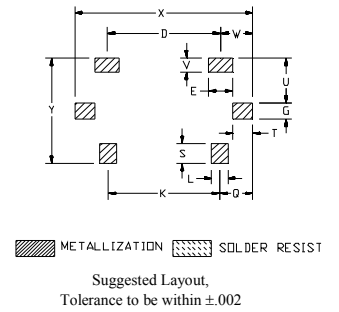

## Outline Dimensions ( inch / mm)

A	B	C	D	E	F	G	H	J	K	L	M
.472	.826	.220	.551	.118	.047	.078	.076	.142	.543	.078	.236
11.99	20.98	5.59	14.00	3.00	1.19	1.98	1.93	3.61	13.79	1.98	5.99
N	P	Q	S	T	U	V	W	X	Y	wt	
.079	.138	.162	.098	.096	.217	.067	.157	.866	.512	grams	
2.01	3.51	4.11	2.49	2.44	5.51	1.70	3.99	22.00	13.00	6.0	

### Notes

- Performance and quality attributes and conditions not expressly stated in this specification document are intended to be excluded and do not form a part of this specification document.
- Electrical specifications and performance data contained in this specification document are based on Mini-Circuit's applicable established test performance criteria and measurement instructions.
- The parts covered by this specification document are subject to Mini-Circuits standard limited warranty and terms and conditions (collectively, "Standard Terms"); Purchasers of this part are entitled to the rights and benefits contained therein. For a full statement of the Standard Terms and the exclusive rights and remedies thereunder, please visit Mini-Circuits' website at [www.minicircuits.com/MCLStore/terms.jsp](http://www.minicircuits.com/MCLStore/terms.jsp)

## Typical Performance Data

FREQ.  (MHz)	INSERTION LOSS			INPUT RETURN LOSS			OUTPUT RETURN LOSS		
	(dB)			(dB)			(dB)		
	@-40°C	@+25°C	@+85°C	@-40°C	@+25°C	@+85°C	@-40°C	@+25°C	@+85°C
0.5	94.04	96.20	93.64	1.10	1.44	1.74	1.14	1.49	1.80
5.0	84.43	83.98	83.29	1.06	1.38	1.66	1.09	1.42	1.71
10.0	79.54	78.71	78.46	0.90	1.17	1.39	0.93	1.20	1.43
15.0	78.21	77.25	79.02	0.72	0.92	1.09	0.74	0.95	1.12
20.0	77.94	77.49	77.60	0.56	0.71	0.83	0.57	0.72	0.85
25.0	78.08	78.22	78.60	0.43	0.54	0.63	0.44	0.55	0.64
30.0	78.47	78.91	78.66	0.33	0.41	0.48	0.34	0.42	0.48
35.0	80.89	82.79	81.36	0.25	0.31	0.36	0.26	0.31	0.36
40.0	92.39	90.56	92.03	0.19	0.23	0.27	0.20	0.24	0.27
45.0	65.05	64.76	64.53	0.16	0.18	0.21	0.16	0.18	0.21
50.0	45.39	45.03	44.71	0.20	0.23	0.25	0.18	0.21	0.25
52.0	35.34	34.91	34.50	0.34	0.38	0.42	0.29	0.34	0.40
55.0	14.05	13.58	13.19	2.21	2.60	3.06	1.93	2.30	2.75
55.5	9.82	9.52	9.33	4.09	4.81	5.62	3.62	4.31	5.10
56.0	6.35	6.35	6.44	8.37	9.66	11.04	7.54	8.74	10.05
56.5	4.38	4.61	4.89	17.41	19.65	21.91	15.70	17.54	19.35
56.8	3.89	4.17	4.48	25.08	28.43	30.20	21.82	23.49	24.06
57.0	3.58	3.88	4.22	34.25	33.25	29.09	24.99	24.27	22.84
57.5	3.27	3.59	3.93	28.50	24.96	22.69	19.76	18.88	18.08
58.0	3.15	3.46	3.80	20.53	19.13	18.16	16.09	15.59	15.26
58.5	3.11	3.42	3.75	16.05	15.72	15.52	13.86	13.81	13.89
59.0	3.10	3.39	3.72	14.37	14.59	14.80	13.28	13.68	14.16
59.5	3.07	3.37	3.71	14.77	15.30	15.67	14.67	15.60	16.58
60.0	3.07	3.40	3.78	16.82	17.13	17.04	19.07	20.88	22.49
60.5	3.17	3.54	3.94	18.00	17.23	16.48	26.25	24.81	23.36
61.0	3.37	3.76	4.20	16.26	15.62	15.28	19.42	18.51	18.16
62.0	4.09	4.65	5.30	19.85	20.59	20.46	19.28	19.22	18.21
62.8	6.40	7.40	8.42	9.60	8.80	8.27	9.50	8.64	8.02
63.0	7.88	8.97	10.04	6.82	6.43	6.21	6.82	6.39	6.10
64.0	15.26	16.29	17.21	2.54	2.65	2.78	2.57	2.68	2.80
65.0	22.07	22.89	23.61	1.49	1.63	1.77	1.51	1.65	1.79
68.0	36.58	37.07	37.46	0.71	0.80	0.89	0.70	0.81	0.91
70.0	43.39	43.77	44.07	0.53	0.61	0.69	0.52	0.62	0.70
80.0	64.72	64.85	65.16	0.26	0.30	0.34	0.24	0.30	0.35
90.0	78.56	77.90	78.39	0.18	0.21	0.24	0.16	0.21	0.25
100.0	92.20	93.18	92.36	0.14	0.17	0.19	0.12	0.16	0.20
200.0	101.89	97.06	102.14	0.04	0.06	0.08	0.02	0.06	0.08
300.0	95.09	94.86	90.91	0.04	0.06	0.08	0.01	0.06	0.08
400.0	91.38	91.74	91.46	0.04	0.07	0.09	0.01	0.07	0.09
500.0	88.60	87.64	88.02	0.05	0.09	0.11	0.01	0.08	0.11
600.0	86.83	85.28	86.15	0.06	0.11	0.13	0.02	0.11	0.14
700.0	86.70	86.72	87.86	0.08	0.13	0.15	0.03	0.13	0.16
800.0	83.69	84.45	86.23	0.10	0.15	0.18	0.05	0.15	0.18
900.0	87.43	86.60	87.08	0.11	0.17	0.19	0.06	0.17	0.21
1000.0	80.24	83.87	83.68	0.12	0.18	0.21	0.08	0.19	0.23
1500.0	67.06	62.43	65.37	0.15	0.23	0.28	0.11	0.25	0.32
2000.0	52.35	56.10	56.76	0.17	0.26	0.33	0.09	0.26	0.37
2500.0	46.20	48.09	49.39	0.15	0.28	0.38	0.05	0.29	0.40
2600.0	44.17	43.38	44.38	0.18	0.31	0.41	0.09	0.32	0.45
3000.0	41.82	41.45	41.35	0.31	0.44	0.53	0.16	0.41	0.58

## Typical Performance Data

FREQ.  (MHz)	GROUP DELAY		
	(nsec)		
	@-40°C	@+25°C	@+85°C
57.0	181.46	176.72	172.12
57.3	171.49	167.56	163.82
57.5	162.68	159.58	156.64
57.8	155.40	152.97	150.68
58.0	149.49	147.61	145.86
58.3	144.67	143.33	142.12
58.5	140.91	140.08	139.33
58.8	138.17	137.84	137.48
59.0	136.46	136.56	136.51
59.3	135.73	136.15	136.30
59.5	135.88	136.45	136.67
59.8	136.68	137.25	137.45
60.0	137.83	138.35	138.50
60.3	139.28	139.66	139.84
60.5	140.91	141.39	141.77
60.8	143.07	143.82	144.59
61.0	146.14	147.50	148.84

## Typical Performance Curves

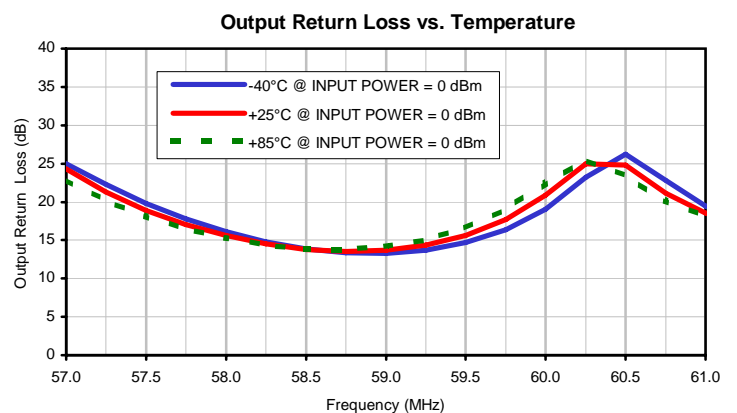
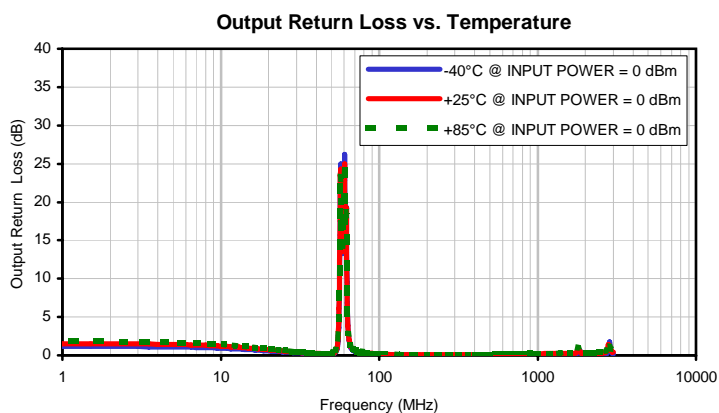
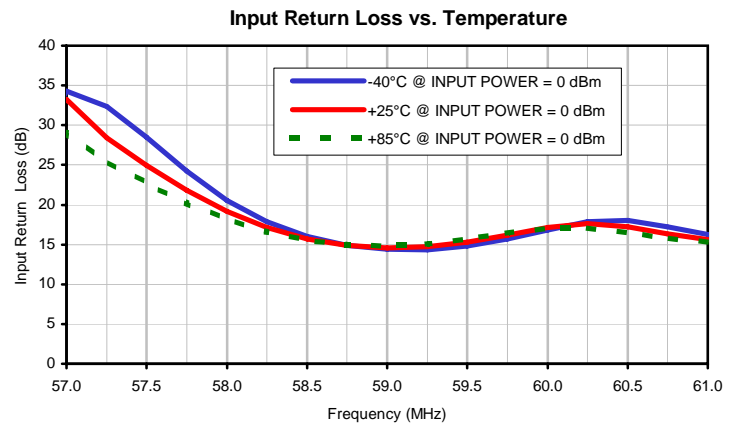
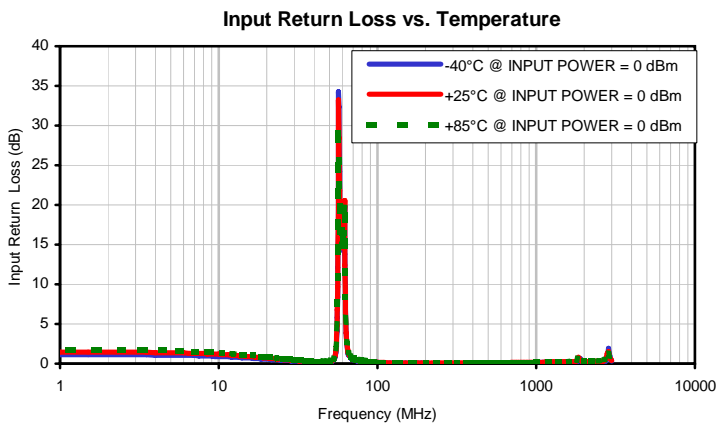
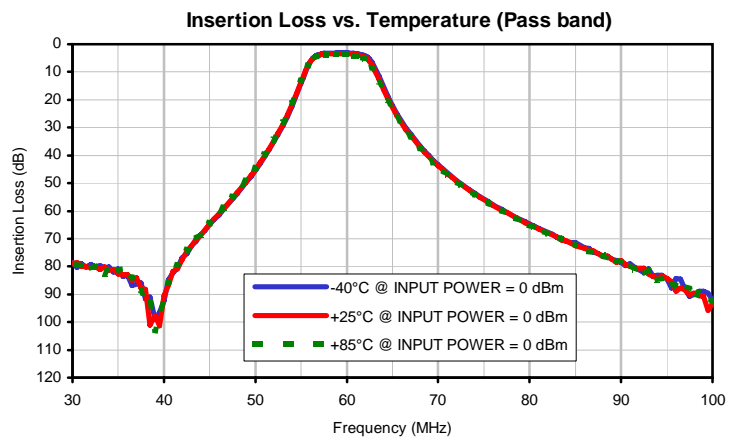
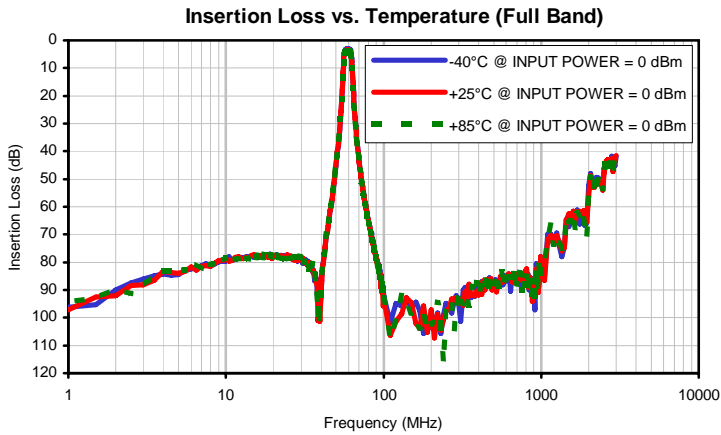

## Typical Performance Curves

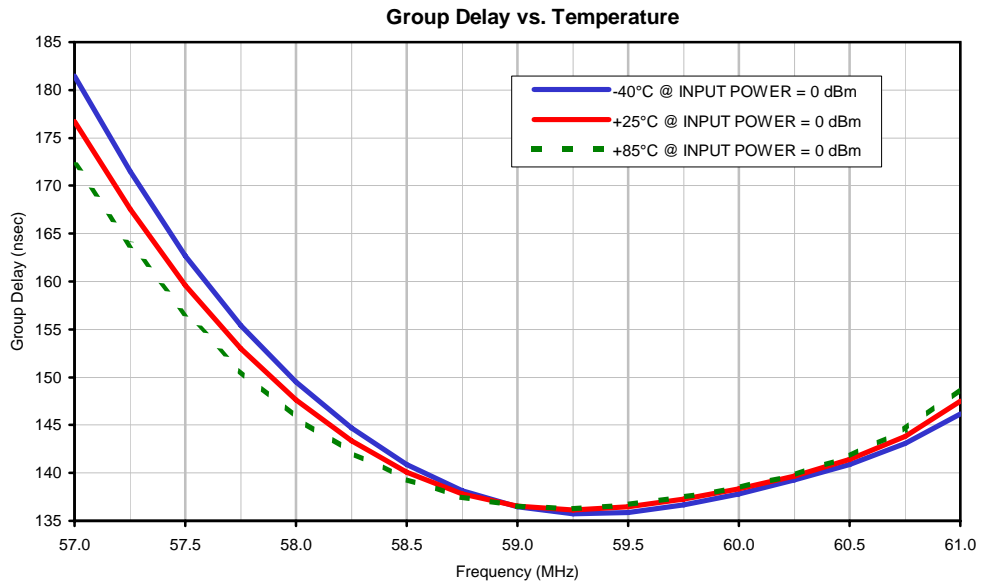

# Case Style

# HZ

## Outline Dimensions

## HZ1198

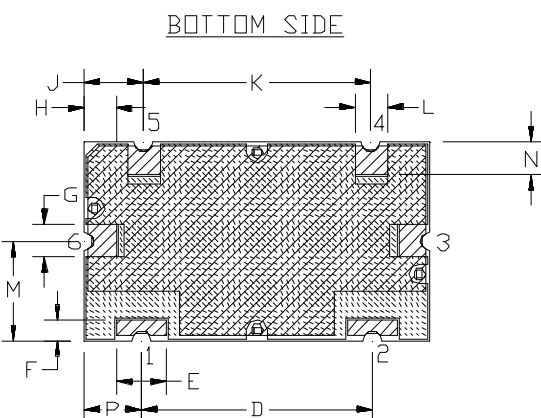
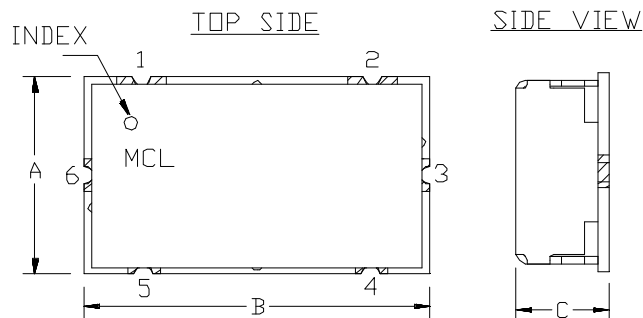

## PCB Land Pattern

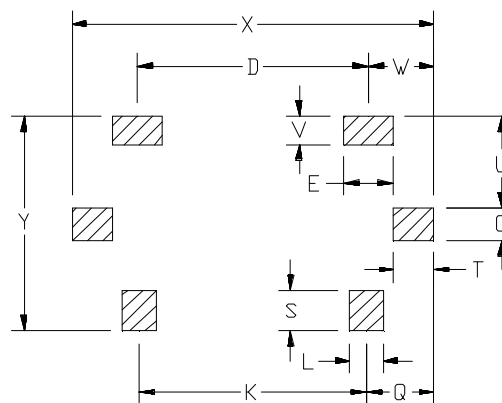

 METALLIZATION  SOLDER RESIST

Suggested Layout,  
Tolerance to be within  $\pm 0.02$

CASE #	A	B	C	D	E	F	G	H	J	K	L	M
HZ1198	.472" (11.99)	.826" (20.98)	.220" (5.59)	.551" (14.00)	.118" (3.00)	.047" (1.19)	.078" (1.98)	.076" (1.92)	.142" (3.61)	.543" (13.79)	.078" (1.98)	.236" (5.99)

CASE #	N	P	Q	S	T	U	V	W	X	Y	WT GRAMS	NOTES
HZ1198	.079" (2.01)	.138" (3.51)	.162" (4.11)	.098" (2.49)	.096" (2.44)	.217" (5.51)	.067" (1.70)	.157" (3.99)	.866" (22.00)	.512" (13.00)	6.0	A35

Dimensions are in inches (mm). Tolerances: 2PL. +/- .03; 3PL. +/- .015

### Notes:

1. Case material: Nickel-Silver alloy.
2. Base: Printed wiring laminate.
3. Termination finish:

For RoHS Case Styles: 3-5  $\mu$ inch (.08-13 microns) Gold over 120-240  $\mu$ inch (3.05-6.10 microns) Nickel plate.  
For RoHS-5 Case Styles: Tin-Lead plate.

  
ISO 9001 ISO 14001 CERTIFIED

ALL NEW  

P.O. Box 350166, Brooklyn, New York 11235-0003 (718) 934-4500 Fax (718) 332-4661 For detailed performance specs & shopping online see Mini-Circuits web site



The Design Engineers Search Engine Provides ACTUAL Data Instantly From MINI-CIRCUITS At: [www.minicircuits.com](http://www.minicircuits.com)

RF/IF MICROWAVE COMPONENTS



# Tape & Reel Packaging TR-F6

## DEVICE ORIENTATION IN T&R

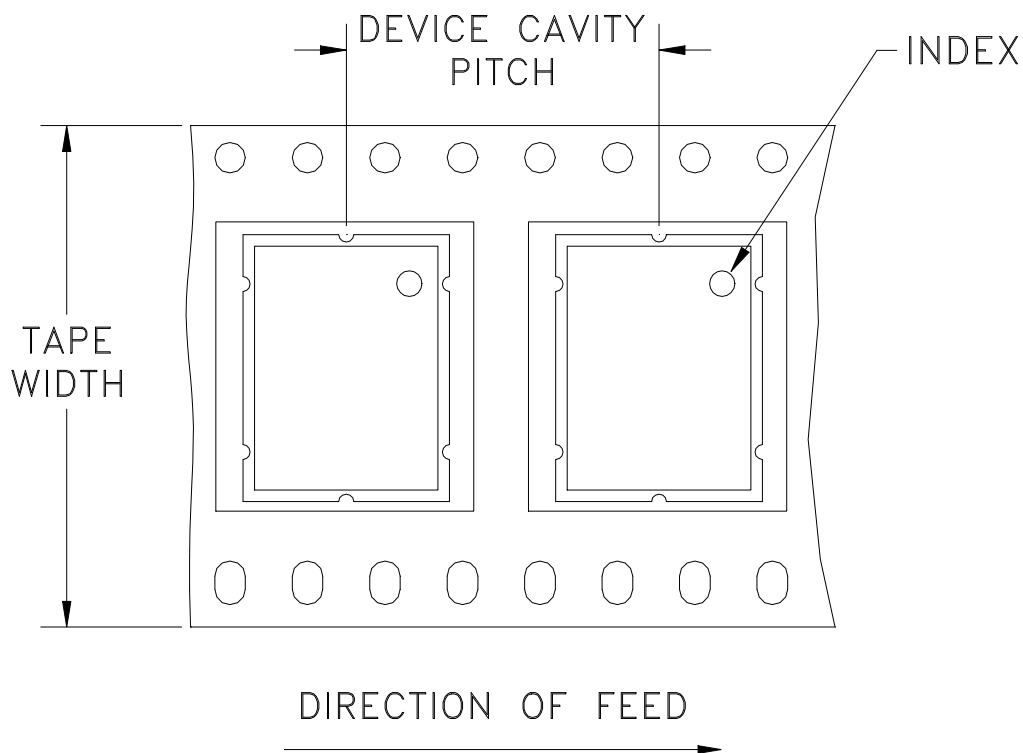

Tape Width, mm	Device Cavity Pitch, mm	Reel Size, inches	Devices per Reel
32	16	13	500

Mini-Circuits carrier tape materials provide protection from ESD (Electro-Static Discharge) during handling and transportation. Tapes are static dissipative and comply with industry standards EIA-481/EIA-541.

Go to: [www.minicircuits.com/pages/pdfs/tape.pdf](http://www.minicircuits.com/pages/pdfs/tape.pdf)



**Distribution Centers** NORTH AMERICA 800-654-7949 • 417-335-5935 • Fax 417-335-5945 • EUROPE 44-1252-832600 • Fax 44-1252-837010

Mini-Circuits ISO 9001 & ISO 14001 Certified

INTERNET <http://www.minicircuits.com>

P.O. Box 350166, Brooklyn, New York 11235-0003 (718) 934-4500 Fax (718) 332-4661

THIRD ANGLE PROJECTION

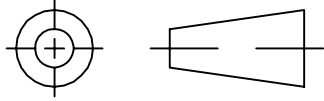

REVISIONS

REV	ECN No.	DESCRIPTION	DATE	DR	AUTH
OR	M107879	NEW RELEASE (FROM RAVON)	11/06	DK	HH
OR	R66100	NEW RELEASE (FROM RAVON)	11/06	DK	HH

**SUGGESTED MOUNTING CONFIGURATION FOR  
HZ1198 CASE STYLE, "rg" PIN CONNECTION, 50 Ω**

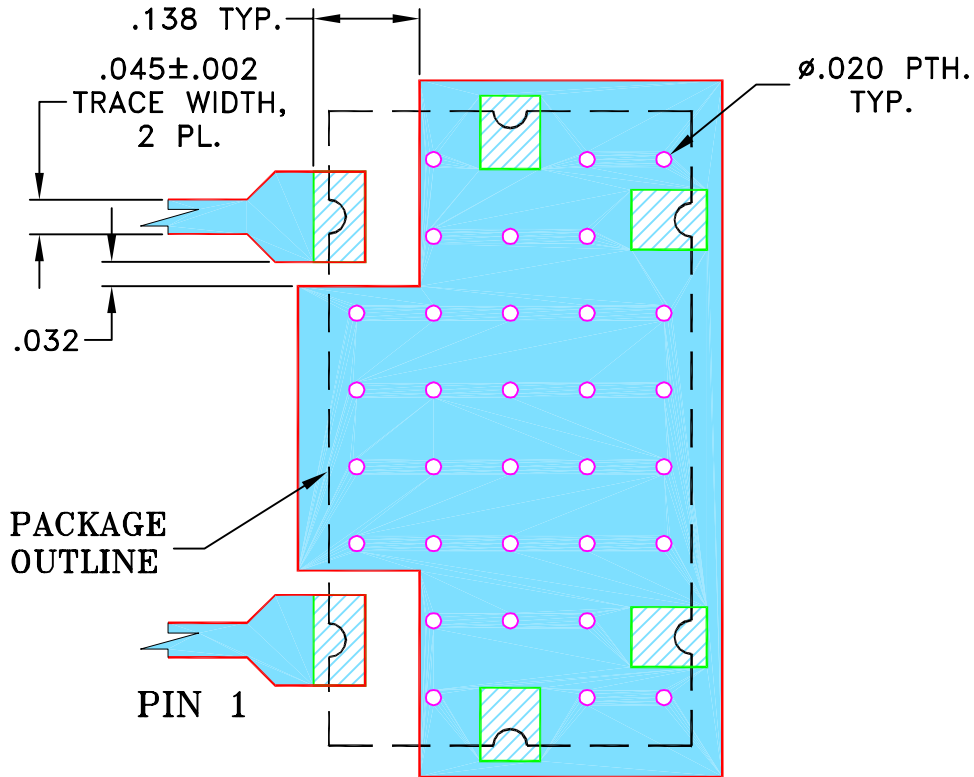

NOTES:

- TRACE WIDTH IS SHOWN FOR FR4 WITH DIELECTRIC THICKNESS  $.025 \pm .002$ ". COPPER: 1/2 OZ. EACH SIDE.  
FOR OTHER MATERIALS TRACE WIDTH MAY NEED TO BE MODIFIED.
- BOTTOM SIDE OF THE PCB IS CONTINUOUS GROUND PLANE.

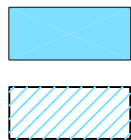

DENOTES PCB COPPER LAYOUT WITH SMOBC  
(SOLDER MASK OVER BARE COPPER)

DENOTES COPPER LAND PATTERN FREE OF SOLDERMASK

UNLESS OTHERWISE SPECIFIED	INITIALS	DATE
DIMENSIONS ARE IN INCHES TOLERANCES ON: 2 PL DECIMALS ± 3 PL DECIMALS ± .005 ANGLES ± FRACTIONS ±	DRAWN	DK (RAVON) 14 NOV 06
	CHECKED	RZ (RAVON) 14 NOV 06
	APPROVED	HH (RAVON) 14 NOV 06

 **Mini-Circuits®** 13 Neptune Avenue  
Brooklyn NY 11235

PL, rg, HZ1198, DPLX, TB-400+  
50 Ω

 Mini-Circuits®  
THIS DOCUMENT AND ITS CONTENTS ARE THE PROPERTY OF MINI-CIRCUITS. EXCEPT FOR USE EXPRESSLY GRANTED, IN WRITING, TO ITS VENDORS, VENDEE AND THE UNITED STATES GOVERNMENT, MINI-CIRCUITS RESERVES ALL PROPRIETARY DESIGN, USE, MANUFACTURING AND REPRODUCTION RIGHTS THERETO. THESE CONTENTS SHALL NOT BE USED, DUPLICATED OR DISCLOSED TO ANY OUTSIDE PARTY, IN WHOLE OR IN PART, WITHOUT WRITTEN PERMISSION OF MINI-CIRCUITS.

SIZE A	CODE IDENT 15542	DRAWING NO: 98-PL-247	REV: OR
FILE: 98PL247	SCALE: 4:1	SHEET: 1 OF 1	

# Evaluation Board and Circuit

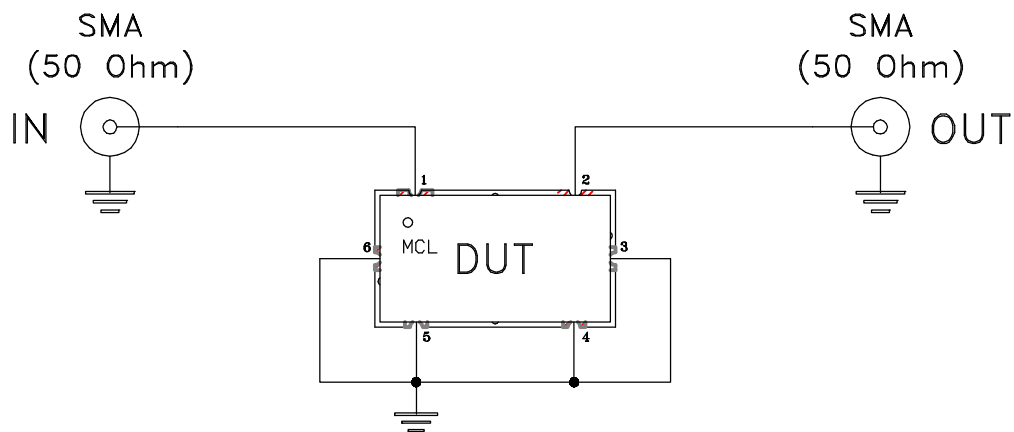
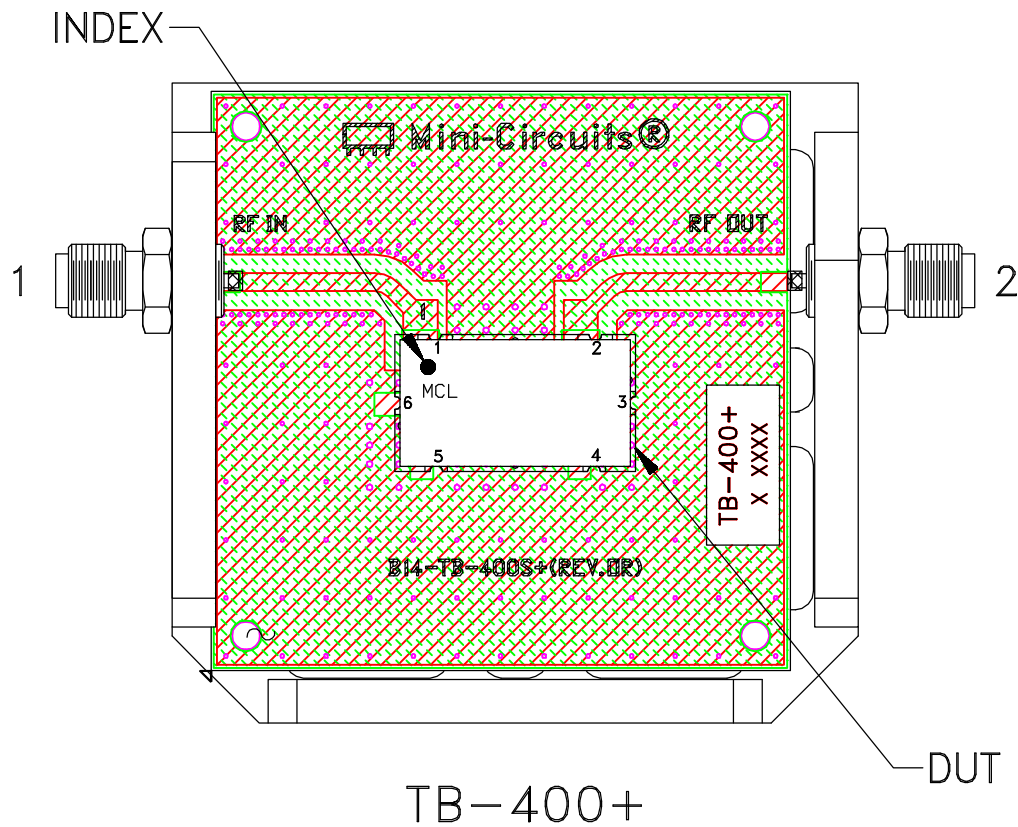

Schematic Diagram

## Notes:

1. 50 Ohm SMA Female connectors.
2. PCB Material: R04350 or equivalent.  
Dielectric Constant=3.5, Thickness=.030 inch.

 **Mini-Circuits®**

All Mini-Circuits products are manufactured under exacting quality assurance and control standards, and are capable of meeting published specifications after being subjected to any or all of the following physical and environmental test.

Specification	Test/Inspection Condition	Reference/Spec
Operating Temperature	-40° to 85° C Ambient Environment	Individual Model Data Sheet
Storage Temperature	-65° to 150° C Ambient Environment	Individual Model Data Sheet
Autoclave	15 psig, 100% RH, 121°C, 96 hours	JESD22-A102-C, Condition C
Temperature Cycling	-65° to 150°C, 100 cycles	JESD22-A104
Temperature Humidity	85°C/ 85% RH, 168 hours	JESD22-113
Solder Reflow Heat	Sn-Pb Eutetic Process: 240°C peak Pb-Free Process: 260°C peak	J-STD-020, Table 4-1, 4-2 and 5-2; Figure 5-1
Moisture Sensitivity: Level 1	Bake at 125°C for 24 hours Soak at 85°C/85% RH for 168 hours, Reflow 3 cycles at 240°C peak (Non-RoHS) or 260°C (RoHS)	J-STD-020
Solderability	10X magnification, 95% coverage	JESD22-B102, Method 1: Dip and Look Test
Mechanical Shock	50g, 11 ms, 1/2-sine, 18 shocks: 3 each direction, each of 3 axes	MIL-STD-202, Method 213, Condition A
Vibration (High Frequency)	20g peak, 10-2000 Hz, 12 times in each of three perpendicular directions (total 36)	MIL-STD-202, Method 204, Condition D