

Surface Mount Bandpass Filter

BPF-C73+

50Ω 63 to 85 MHz

Maximum Ratings

Operating Temperature	-40°C to 85°C
Storage Temperature	-55°C to 100°C
RF Power Input	0.5W Max.
Permanent damage may occur if any of these limits are exceeded.	

Pin Connections

INPUT	2
OUTPUT	9
NOT CONNECTED	6,13
GROUND	1, 3, 4, 5, 7,8,10,11,12,14

Outline Drawing

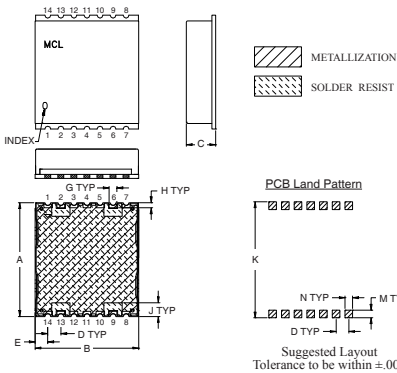

Outline Dimensions (inch/mm)

A	B	C	D	E	G	H	J	K	M	N	wt.
.870	.800	.25	.100	.097	.060	.040	.105	.910	.060	.060	grams
22.10	20.32	6.35	2.54	2.46	1.52	1.02	2.67	23.11	1.52	1.52	2.85

Note: Please refer to case style drawing for details

Demo Board MCL P/N: TB-500+ Suggested PCB Layout (PL-294)

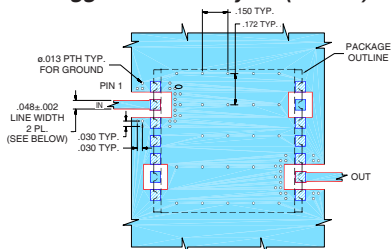

- NOTES:
- TRACE WIDTH IS SHOWN FOR ROGERS RO4350B, DIELECTRIC THICKNESS: .030±.002; COPPER: 1/2 OZ EACH SIDE. FOR OTHER MATERIALS TRACE WIDTH MAY NEED TO BE MODIFIED.
 - BOTTOM SIDE OF THE PCB IS CONTINUOUS GROUND PLANE.
- DENOTES PCB COPPER LAYOUT WITH SMOBC (SOLDER MASK OVER BARE COPPER)
 - DENOTES COPPER LAND PATTERN FREE OF SOLDER MASK

Features

- High rejection
- Good VSWR, 1.2:1 typ @ passband
- Flat group delay
- Shielded case
- Aqueous washable

Applications

- Industrial microwave and RF
- Receivers / transmitters
- Harmonic rejection



Generic photo used for illustration purposes only
CASE STYLE: HU1186

+RoHS Compliant

The +Suffix identifies RoHS Compliance. See our web site for RoHS Compliance methodologies and qualifications

Bandpass Filter Electrical Specifications (T_{AMB} = 25°C)

CENTER FREQ. (MHz)	PASSBAND (MHz) (Loss < 2dB)	STOPBANDS (MHz)				VSWR (:1)		
		Loss > 20dB		Loss > 40dB		Passband		Stopband
F _c	F ₁ - F ₂	F ₃	F ₄	F ₅	F ₆	Typ.	Max.	Typ.
73	63 - 85	45	105	40	110 - 550	1.2	1.6	18

Typical Frequency Response

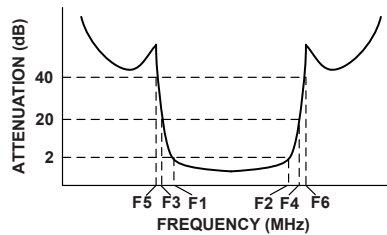

Functional Schematic

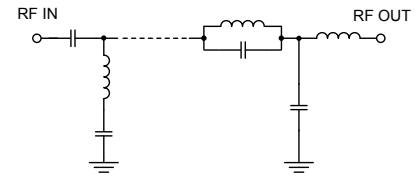

Typical Performance Data at 25°C

Frequency (MHz)	Insertion Loss (dB)		Return Loss (dB)	Frequency (MHz)	Group Delay (nSec)
	\bar{x}	σ			
1.0	72.16	0.34	0.01	60.0	48.69
40.0	62.23	5.02	0.13	61.0	45.08
45.0	39.35	4.53	0.24	62.0	41.06
50.0	18.88	3.18	0.49	63.0	38.21
53.0	9.99	2.53	1.12	64.0	36.00
55.0	5.38	1.66	2.61	66.0	33.01
57.0	2.48	0.69	6.51	70.0	29.66
63.0	0.84	0.05	21.21	72.0	28.69
70.0	0.77	0.02	22.12	73.0	28.29
73.0	0.82	0.02	18.54	74.0	27.98
80.0	1.00	0.03	16.98	75.0	27.81
85.0	1.16	0.02	19.23	76.0	27.71
94.0	2.44	0.05	18.08	80.0	28.33
97.0	6.11	0.31	5.16	82.0	29.28
100.0	14.51	0.29	2.20	84.0	30.65
105.0	30.91	0.28	1.32	85.0	31.49
110.0	52.83	1.53	1.04	87.0	33.60
550.0	55.83	0.26	0.94	90.0	38.60

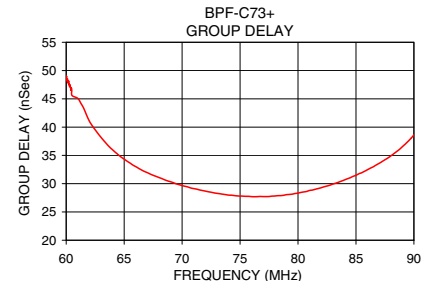
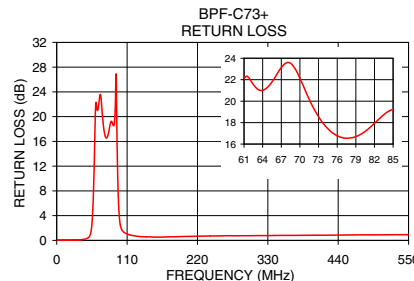
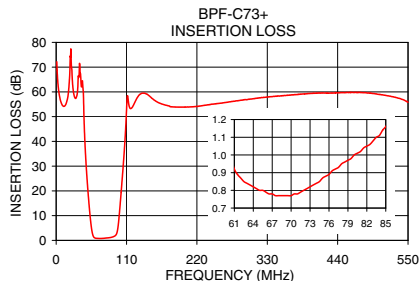

- Notes
- Performance and quality attributes and conditions not expressly stated in this specification document are intended to be excluded and do not form a part of this specification document.
 - Electrical specifications and performance data contained in this specification document are based on Mini-Circuit's applicable established test performance criteria and measurement instructions.
 - The parts covered by this specification document are subject to Mini-Circuit's standard limited warranty and terms and conditions (collectively, "Standard Terms"); Purchasers of this part are entitled to the rights and benefits contained therein. For a full statement of the Standard Terms and the exclusive rights and remedies thereunder, please visit Mini-Circuit's website at www.minicircuits.com/MCLStore/terms.jsp



www.minicircuits.com P.O. Box 350166, Brooklyn, NY 11235-0003 (718) 934-4500 sales@minicircuits.com

REV. B
M174392
EDR-9255/1UF1
BPF-C73+
URJ/RAV
190808
Page 1 of 1

Surface Mount Band Pass Filter

BPF-C73+

Typical Performance Data

FREQ. (MHz)	INSERTION LOSS (dB)			INPUT RETURN LOSS (dB)			OUTPUT RETURNLOSS (dB)		
	@ -40° C	@ +25° C	@ +85° C	@ -40° C	@ +25° C	@ +85° C	@ -40° C	@ +25° C	@ +85° C
1	72.94	72.06	72.55	0.00	0.00	0.00	0.00	0.00	0.00
10	55.00	54.99	54.93	0.00	0.01	0.01	0.04	0.06	0.06
15	55.49	55.66	55.53	0.01	0.01	0.01	0.09	0.13	0.14
20	62.36	62.40	62.26	0.02	0.02	0.02	0.17	0.21	0.23
25	68.89	69.20	68.84	0.03	0.04	0.04	0.25	0.29	0.30
30	66.12	66.80	66.67	0.05	0.06	0.07	0.32	0.35	0.36
35	57.38	57.03	56.93	0.09	0.11	0.12	0.37	0.40	0.42
40	56.88	57.40	57.62	0.16	0.18	0.21	0.45	0.50	0.55
45	29.07	28.62	28.51	0.32	0.36	0.39	0.64	0.73	0.78
50	10.61	10.41	10.48	1.27	1.38	1.42	1.53	1.66	1.68
53	3.45	3.37	3.43	5.16	5.53	5.62	5.10	5.44	5.46
55	1.50	1.51	1.55	11.77	12.64	13.03	10.93	11.60	11.80
57	0.97	1.02	1.07	19.45	20.73	21.23	17.28	18.02	18.08
60	0.83	0.89	0.94	18.70	18.79	18.34	18.28	18.26	17.71
63	0.76	0.82	0.86	20.19	20.51	20.15	19.53	19.69	19.29
64	0.74	0.80	0.84	21.45	21.95	21.67	20.46	20.75	20.46
65	0.73	0.78	0.83	22.89	23.62	23.51	21.53	21.94	21.82
66	0.72	0.78	0.82	24.26	25.21	25.39	22.51	23.04	23.13
67	0.72	0.78	0.82	24.96	25.95	26.48	23.13	23.67	23.96
68	0.72	0.78	0.82	24.66	25.37	26.03	23.15	23.55	23.90
69	0.73	0.79	0.83	23.61	24.00	24.54	22.62	22.81	23.10
70	0.74	0.81	0.85	22.40	22.55	22.94	21.77	21.76	21.95
73	0.80	0.87	0.92	19.60	19.47	19.65	19.36	19.11	19.16
74	0.83	0.90	0.95	19.03	18.87	19.04	18.79	18.52	18.59
75	0.85	0.93	0.98	18.68	18.48	18.66	18.37	18.09	18.20
80	0.98	1.07	1.12	19.12	18.95	19.44	18.75	18.72	19.46
85	1.20	1.32	1.40	24.22	22.91	22.43	26.53	25.88	26.06
90	2.05	2.25	2.39	13.87	13.26	12.85	17.11	16.91	16.91
94	6.04	6.55	6.86	4.56	4.40	4.33	6.07	5.98	6.01
97	14.09	14.79	15.19	1.92	1.94	1.96	2.48	2.49	2.50
100	24.23	24.94	25.31	1.26	1.33	1.36	1.43	1.48	1.48
101	27.88	28.58	28.93	1.16	1.23	1.27	1.26	1.31	1.32
102	31.71	32.42	32.77	1.09	1.15	1.19	1.13	1.18	1.19
103	35.85	36.59	36.92	1.02	1.09	1.13	1.02	1.08	1.09
104	40.50	41.26	41.59	0.97	1.04	1.07	0.94	1.00	1.01
105	45.96	46.84	47.08	0.92	0.99	1.03	0.87	0.93	0.94
106	52.51	53.19	53.41	0.89	0.95	0.99	0.82	0.87	0.88
107	56.07	55.83	55.45	0.85	0.92	0.95	0.77	0.82	0.83
108	53.52	53.22	53.15	0.82	0.88	0.92	0.73	0.78	0.79
109	51.63	51.51	51.30	0.79	0.85	0.89	0.69	0.75	0.76
110	50.56	50.57	50.55	0.77	0.83	0.86	0.66	0.71	0.73
120	56.16	56.27	56.36	0.61	0.66	0.70	0.48	0.53	0.55
130	63.80	63.99	63.48	0.56	0.60	0.63	0.41	0.45	0.47
140	62.00	62.18	61.97	0.54	0.58	0.61	0.36	0.40	0.42
150	58.45	58.39	58.58	0.56	0.59	0.62	0.34	0.38	0.38
160	56.01	56.02	56.11	0.59	0.62	0.64	0.32	0.35	0.35
170	54.65	54.71	54.79	0.61	0.64	0.66	0.30	0.33	0.34
200	53.54	53.48	53.52	0.65	0.71	0.72	0.26	0.30	0.32
250	54.91	54.76	54.75	0.65	0.77	0.78	0.23	0.28	0.30
300	56.65	56.55	56.36	0.65	0.79	0.80	0.21	0.27	0.29
350	58.01	58.04	58.00	0.66	0.82	0.82	0.21	0.28	0.31
400	58.90	58.99	58.89	0.66	0.86	0.84	0.21	0.29	0.31
450	59.39	59.34	59.13	0.69	0.90	0.88	0.21	0.30	0.33
500	58.56	58.80	58.60	0.71	0.95	0.92	0.21	0.31	0.35
550	55.32	55.38	55.07	0.74	1.00	0.96	0.22	0.33	0.36

REV. X1
BPF-C73+
091126



IF/RF MICROWAVE COMPONENTS • ISO 9001 ISO 14001 AS 9100 CERTIFIED • RoHS compliant
P.O. Box 350166, Brooklyn, New York 11235-0003 (718) 934-4500 Fax (718) 332-4661



The Design Engineers Search Engine finds the model you need, Instantly • For detailed performance specs & shopping online see



Page 1 of 2

Surface Mount Band Pass Filter

BPF-C73+

Typical Performance Data

FREQ. (MHz)	GROUP DELAY (nsec)		
	@ -40° C	@ +25° C	@ +85° C
63.00	32.57	32.46	32.41
63.50	32.00	31.93	31.88
64.00	31.53	31.46	31.43
64.50	31.08	31.03	30.99
65.00	30.67	30.63	30.60
65.50	30.33	30.31	30.26
66.00	29.98	29.96	29.94
66.50	29.65	29.64	29.64
67.00	29.39	29.38	29.37
67.50	29.12	29.12	29.11
68.00	28.87	28.86	28.87
68.50	28.67	28.66	28.68
69.00	28.46	28.45	28.47
69.50	28.29	28.28	28.29
70.00	28.12	28.13	28.13
70.50	27.98	27.99	28.00
71.00	27.87	27.86	27.88
71.50	27.77	27.78	27.79
72.00	27.66	27.70	27.69
72.50	27.61	27.64	27.62
73.00	27.56	27.60	27.61
73.50	27.56	27.57	27.58
74.00	27.53	27.55	27.57
74.50	27.55	27.60	27.59
75.00	27.60	27.64	27.64
75.50	27.68	27.70	27.72
76.00	27.75	27.79	27.82
76.50	27.86	27.90	27.92
77.00	27.99	28.05	28.08
77.50	28.17	28.24	28.25
78.00	28.34	28.42	28.46
78.50	28.56	28.65	28.70
79.00	28.79	28.86	28.93
79.50	29.01	29.10	29.18
80.00	29.25	29.33	29.43
80.25	29.44	29.57	29.67
80.50	29.69	29.79	29.91
80.75	29.91	30.03	30.15
81.00	30.10	30.23	30.36
81.25	30.29	30.48	30.56
81.50	30.52	30.70	30.82
81.75	30.72	30.94	31.03
82.00	31.01	31.17	31.30
82.25	31.21	31.42	31.53
82.50	31.46	31.69	31.78
82.75	31.75	31.99	32.06
83.00	32.07	32.27	32.41
83.25	32.27	32.51	32.64
83.50	32.64	32.86	32.99
83.75	32.95	33.22	33.29
84.00	33.27	33.53	33.67
84.25	33.65	33.89	34.03
84.50	33.97	34.21	34.37
84.75	34.33	34.59	34.72
85.00	34.77	35.05	35.16

REV. X1
BPF-C73+
091126
Page 2 of 2



IF/RF MICROWAVE COMPONENTS • ISO 9001 ISO 14001 AS 9100 CERTIFIED RoHS compliant
P.O. Box 350166, Brooklyn, New York 11235-0003 (718) 934-4500 Fax (718) 332-4661



The Design Engineers Search Engine finds the model you need, Instantly • For detailed performance specs & shopping online see



Typical Performance Curves

INSERTION LOSS vs. TEMPERATURE

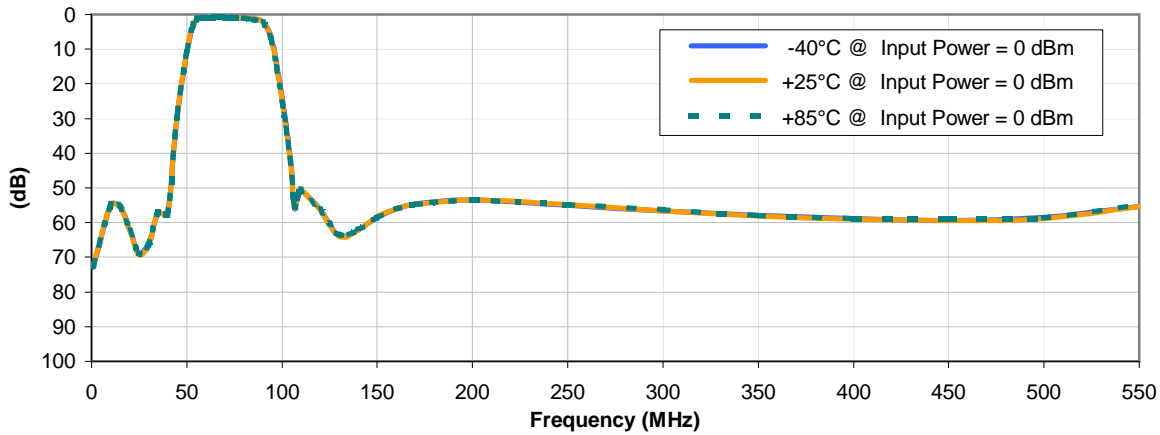

INPUT RETURN LOSS vs. TEMPERATURE

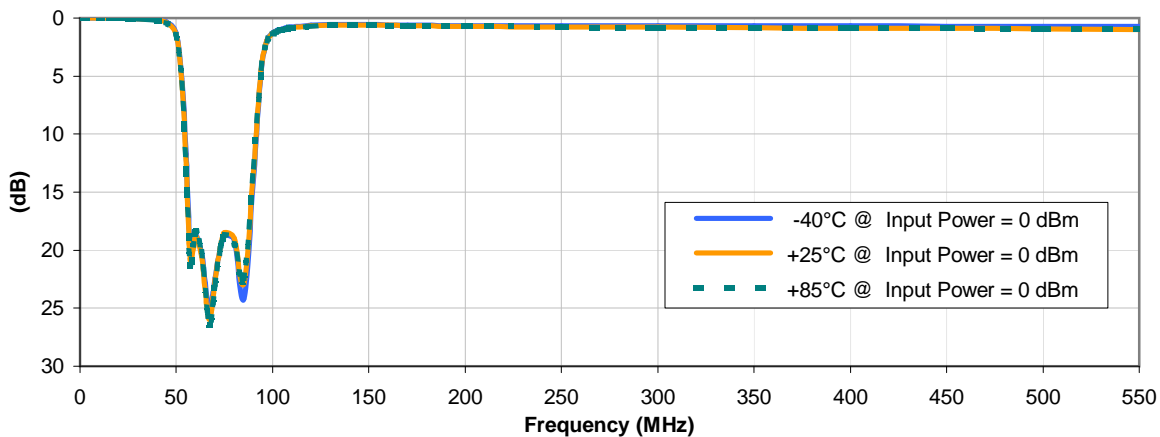

OUTPUT RETURN LOSS vs. TEMPERATURE

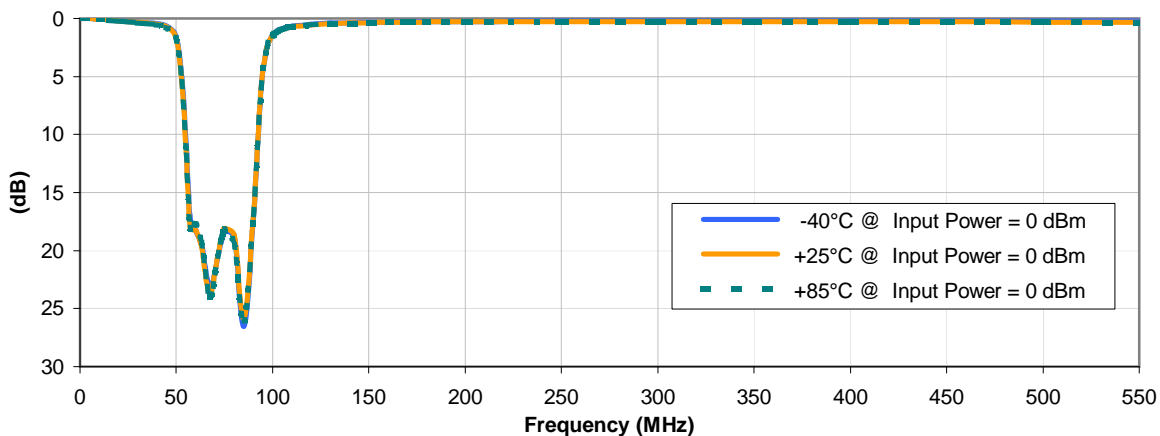

Typical Performance Curves

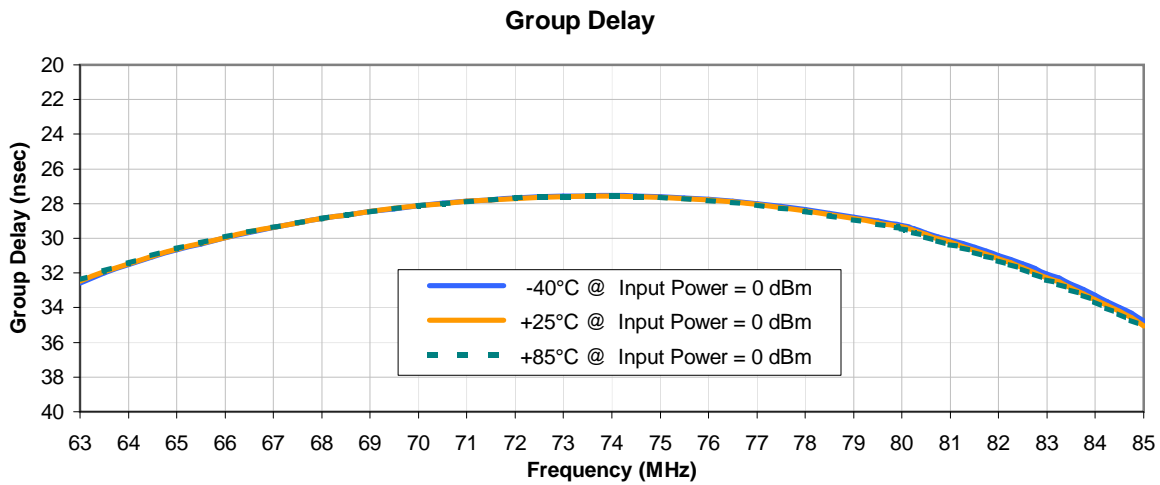

Outline Dimensions

HU1186

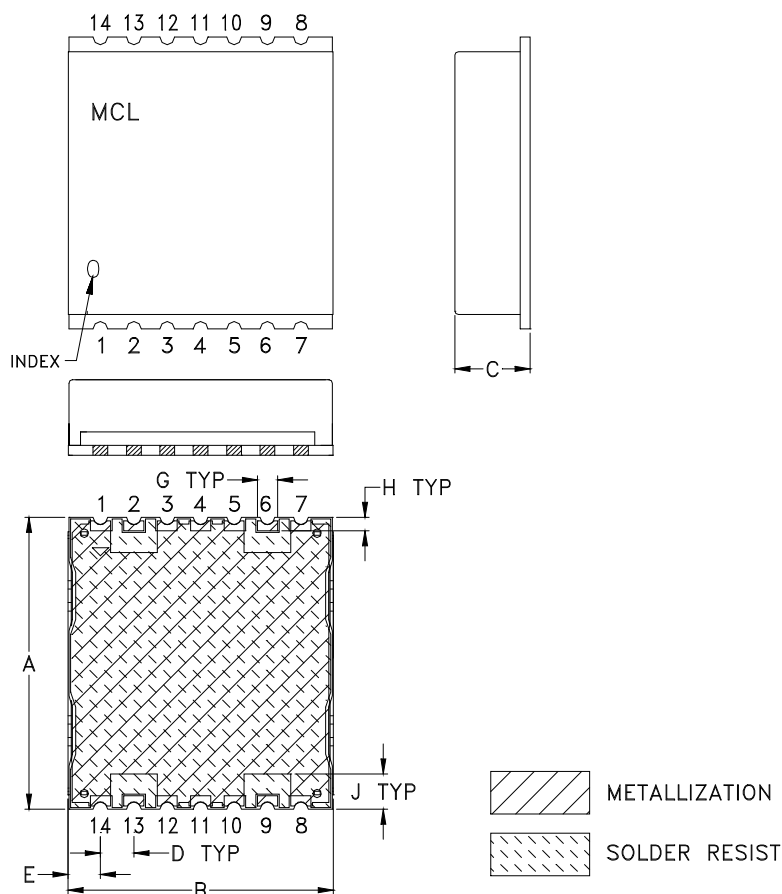

PCB Land Pattern

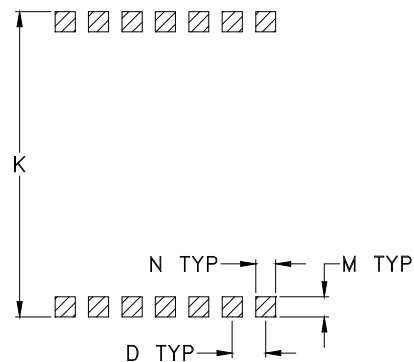

Suggested Layout,
Tolerance to be within ± 0.002

CASE#	A	B	C	D	E	F	G	H	J	K	L	M	N	P	WT, GRAM
HU1186	.870 (22.10)	.800 (20.32)	.25 (6.35)	.100 (2.54)	.097 (2.46)	-	.060 (1.52)	.040 (1.02)	.105 (2.67)	.910 (23.11)	-	.060 (1.52)	.060 (1.52)	-	2.85

Dimensions are in inches (mm). Tolerances: 2PL. +/- .03; 3PL. +/- .015

Notes:

- Case material: Nickel-Silver alloy.
- Base: Printed wiring laminate.
- Termination finish:
For RoHS Case Styles: 2-5 μ inch (.05-.13 microns) Gold over 120-240 μ inch (3.05-6.10 microns) Nickel plate.
For RoHS-5 Case Styles: Tin-Lead plate.



P.O. Box 350166, Brooklyn, New York 11235-0003 (718) 934-4500 Fax (718) 332-4661 For detailed performance specs & shopping online see Mini-Circuits web site



The Design Engineers Search Engine Provides ACTUAL Data Instantly From MINI-CIRCUITS At: www.minicircuits.com

RF/IF MICROWAVE COMPONENTS

Tape & Reel Packaging TR-F21

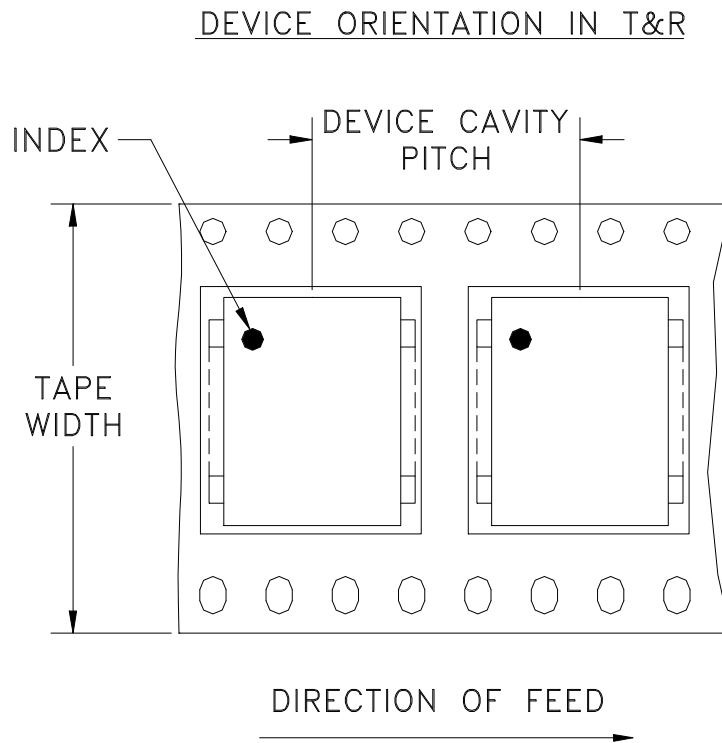

Tape Width, mm	Device Cavity Pitch, mm	Reel Size, inches	Devices per Reel
32	32	13	200

Mini-Circuits carrier tape materials provide protection from ESD (Electro-Static Discharge) during handling and transportation. Tapes are static dissipative and comply with industry standards EIA-481/EIA-541.

Go to: www.minicircuits.com/pages/pdfs/tape.pdf



INTERNET <http://www.minicircuits.com>

P.O. Box 350166, Brooklyn, New York 11235-0003 (718) 934-4500 Fax (718) 332-4661

Distribution Centers NORTH AMERICA 800-654-7949 • 417-335-5935 • Fax 417-335-5945 • EUROPE 44-1252-832600 • Fax 44-1252-837010

Mini-Circuits ISO 9001 & ISO 14001 Certified

THIRD ANGLE PROJECTION

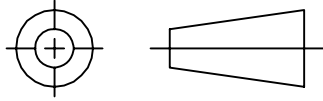

REVISIONS

REV	ECN No.	DESCRIPTION	DATE	DR	AUTH
OR	M119979	NEW RELEASE (FROM RAVON)	11/08	DK	HH
OR	R74463	NEW RELEASE (FROM RAVON)	11/08	DK	HH

SUGGESTED MOUNTING CONFIGURATION FOR HU1186 CASE STYLE, "14FL03" PIN CODE

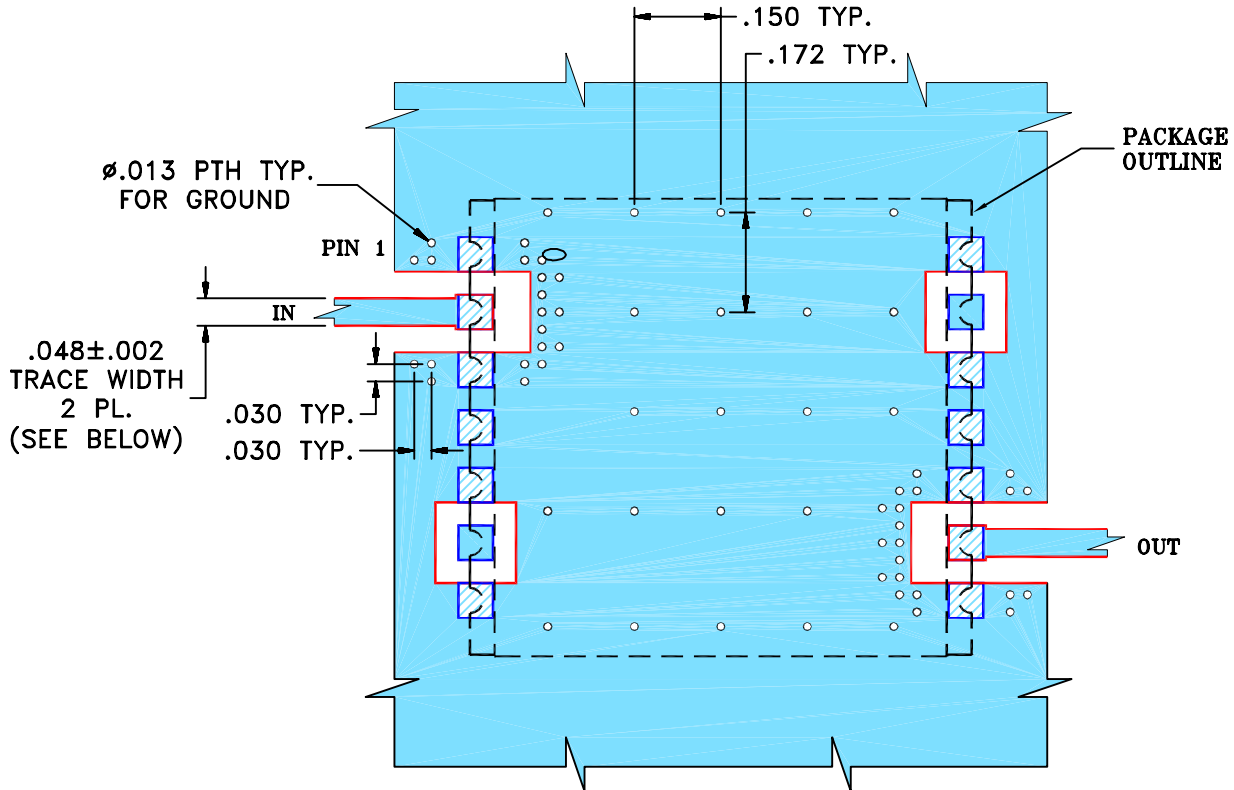

NOTES:

- TRACE WIDTH IS SHOWN FOR ROGERS R04350B, DIELECTRIC THICKNESS: .030" ± .002"; COPPER: 1/2 OZ ON EACH SIDE. FOR OTHER MATERIALS TRACE WIDTH MAY NEED TO BE MODIFIED.
- BOTTOM SIDE OF THE PCB IS CONTINUOUS GROUND PLANE.

- DENOTES PCB COPPER LAYOUT WITH SMOBC (SOLDER MASK OVER BARE COPPER)
- DENOTES COPPER LAND PATTERN FREE OF SOLDERMASK

UNLESS OTHERWISE SPECIFIED	INITIALS	DATE
DIMENSIONS ARE IN INCHES TOLERANCES ON: 2 PL DECIMALS ± 3 PL DECIMALS ± .005 ANGLES ± FRACTIONS ±	DRAWN	DK (RAVON) 02 NOV 08
	CHECKED	DH (RAVON) 02 NOV 08
	APPROVED	HH (RAVON) 02 NOV 08

Mini-Circuits® 13 Neptune Avenue
 Brooklyn NY 11235

PL, 14FL03, HU1186, BPF-C
TB-500+ (50 OHM)

Mini-Circuits®
 THIS DOCUMENT AND ITS CONTENTS ARE THE PROPERTY OF MINI-CIRCUITS. EXCEPT FOR USE EXPRESSLY GRANTED, IN WRITING, TO ITS VENDORS, VENDEE AND THE UNITED STATES GOVERNMENT, MINI-CIRCUITS RESERVES ALL PROPRIETARY DESIGN, USE, MANUFACTURING AND REPRODUCTION RIGHTS THERETO. THESE CONTENTS SHALL NOT BE USED, DUPLICATED OR DISCLOSED TO ANY OUTSIDE PARTY, IN WHOLE OR IN PART, WITHOUT WRITTEN PERMISSION OF MINI-CIRCUITS.

SIZE A	CODE IDENT 15542	DRAWING NO: 98-PL-294	REV: OR
FILE: 98PL294	SCALE: 3:1	SHEET: 1 OF 1	

Evaluation Board and Circuit

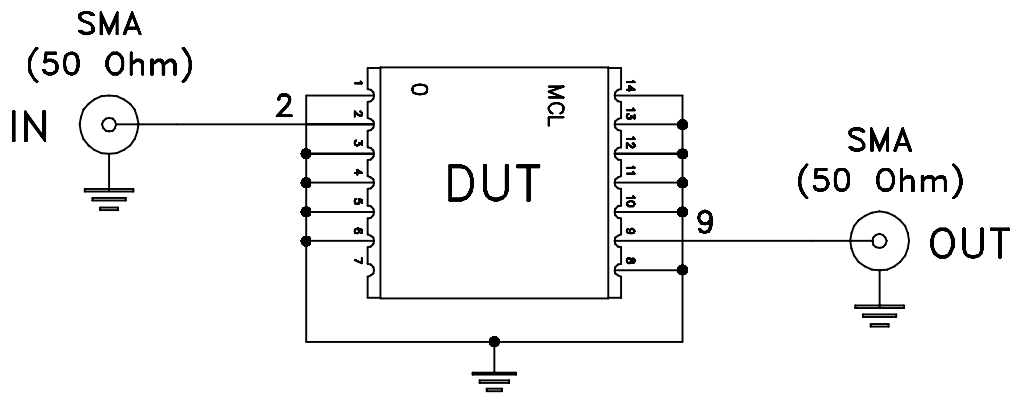
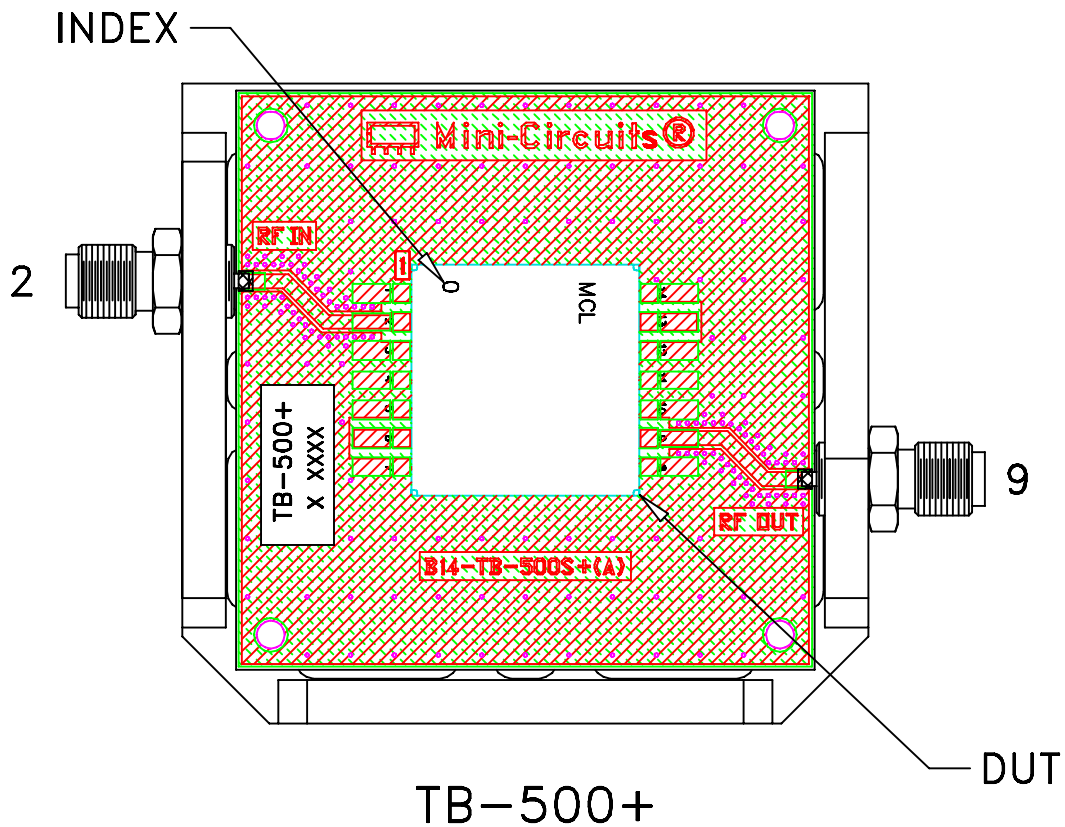

Notes:

1. 50 Ohm SMA Female connectors.
2. PCB Material: R04350 or equivalent.
Dielectric Constant=3.5, Thickness=.030 inch.

Mini-Circuits®

All Mini-Circuits products are manufactured under exacting quality assurance and control standards, and are capable of meeting published specifications after being subjected to any or all of the following physical and environmental test.

Specification	Test/Inspection Condition	Reference/Spec
Operating Temperature	-40° to 85° C Ambient Environment	Individual Model Data Sheet
Storage Temperature	-65° to 150° C Ambient Environment	Individual Model Data Sheet
Autoclave	15 psig, 100% RH, 121°C, 96 hours	JESD22-A102-C, Condition C
Temperature Cycling	-65° to 150°C, 100 cycles	JESD22-A104
Temperature Humidity	85°C/ 85% RH, 168 hours	JESD22-113
Solder Reflow Heat	Sn-Pb Eutetic Process: 240°C peak Pb-Free Process: 260°C peak	J-STD-020, Table 4-1, 4-2 and 5-2; Figure 5-1
Moisture Sensitivity: Level 1	Bake at 125°C for 24 hours Soak at 85°C/85% RH for 168 hours, Reflow 3 cycles at 240°C peak (Non-RoHS) or 260°C (RoHS)	J-STD-020
Solderability	10X magnification, 95% coverage	JESD22-B102, Method 1: Dip and Look Test
Mechanical Shock	50g, 11 ms, 1/2-sine, 18 shocks: 3 each direction, each of 3 axes	MIL-STD-202, Method 213, Condition A
Vibration (High Frequency)	20g peak, 10-2000 Hz, 12 times in each of three perpendicular directions (total 36)	MIL-STD-202, Method 204, Condition D