

# Surface Mount Bandpass Filter

## BPF-V300+

50Ω      230 to 370 MHz



Generic photo used for illustration purposes only  
CASE STYLE: KV1974

### The Big Deal

- Wide bandwidth
- Very low insertion loss, 1.1 dB typical
- Excellent rejection, 50 dB until 10<sup>th</sup> Harmonic
- Shielded package

### Product Overview

The BPF-V300+ is a 50Ω bandpass filter fabricated using SMT technology. This bandpass filter covers from 230-370 MHz. This filter is built with high Q capacitors and wire welded inductors for high reliability. This filter has fast roll-off and developed for surveillance receiver in aircraft systems. It has repeatable performance across lots and consistent performance across temperature.

### Key Features

Feature	Advantages
Low insertion loss	Very low insertion loss enables the filter to be used in high performance applications.
Excellent rejection out to 10 <sup>th</sup> harmonic	This enables the filter to attenuate spurious signals and reject harmonics for broad frequency band.
Shielded case	Reduced interference with and from the surrounding components.

#### Notes

- A. Performance and quality attributes and conditions not expressly stated in this specification document are intended to be excluded and do not form a part of this specification document.  
B. Electrical specifications and performance data contained in this specification document are based on Mini-Circuit's applicable established test performance criteria and measurement instructions.  
C. The parts covered by this specification document are subject to Mini-Circuits standard limited warranty and terms and conditions (collectively, "Standard Terms"); Purchasers of this part are entitled to the rights and benefits contained therein. For a full statement of the Standard Terms and the exclusive rights and remedies thereunder, please visit Mini-Circuits' website at [www.minicircuits.com/MCLStore/terms.jsp](http://www.minicircuits.com/MCLStore/terms.jsp)



# Surface Mount Bandpass Filter

## BPF-V300+

50Ω 230 to 370 MHz



Generic photo used for illustration purposes only  
CASE STYLE: KV1974

### Features

- Wide bandwidth
- Very low insertion loss
- Excellent rejection
- Miniature shielded package

### Applications

- Civil aircraft communication radio
- Defence Applications
- Surveillance receiver
- Emergency Locator Transponders (ELT)

### Electrical Specifications at 25°C

Parameter	F#	Frequency (MHz)	Min.	Typ.	Max.	Unit	
<b>Pass Band</b>	Center Frequency	—	—	300	—	MHz	
	Insertion Loss	F1-F2	230-370	—	1.1	2.0	dB
	VSWR	F1-F2	230-370	—	1.2	1.5	:1
<b>Stop Band, Lower</b>	Insertion Loss	DC-F3	DC-170	25	37	—	dB
	VSWR	DC-F3	DC-170	—	20	—	:1
<b>Stop Band, Upper</b>	Insertion Loss	F4-F5	440-3000	25	38	—	dB
	VSWR	F4-F5	440-3000	—	20	—	:1

### Maximum Ratings

Operating Temperature	-40°C to 85°C
Storage Temperature	-55°C to 100°C
RF Power Input	0.5 W

Permanent damage may occur if any of these limits are exceeded.

### Functional Schematic

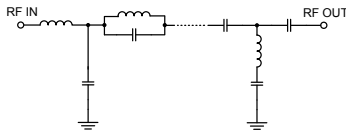

### Typical Frequency Response

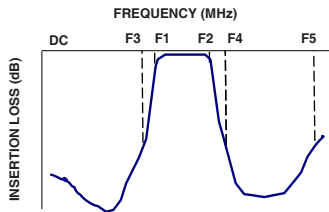

### Typical Performance Data at 25°C

Frequency (MHz)	Insertion Loss (dB)	VSWR (:1)	Frequency (MHz)	Group Delay (nsec)
1	68.59	476.18	230	7.29
10	49.51	550.36	240	6.43
100	69.41	44.87	250	5.92
170	44.78	23.43	260	5.54
176	29.58	18.88	270	5.28
180	20.58	14.92	280	5.10
186	10.62	7.85	290	4.99
194	3.01	2.14	295	4.96
230	0.88	1.16	300	4.96
300	0.77	1.17	305	4.97
370	1.10	1.11	310	5.01
395	2.44	1.78	315	5.06
400	3.60	2.34	320	5.13
412	10.51	4.68	330	5.31
420	20.14	6.85	335	5.43
426	31.66	8.90	340	5.57
440	37.47	14.49	345	5.74
1000	47.06	126.08	350	5.94
2000	78.14	49.43	360	6.45
3000	62.75	63.48	370	7.41

### +RoHS Compliant

The +Suffix identifies RoHS Compliance. See our web site for RoHS Compliance methodologies and qualifications

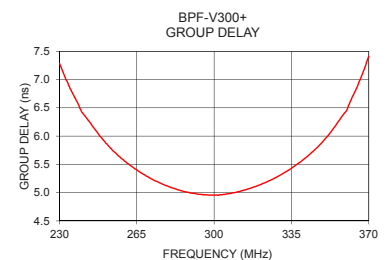
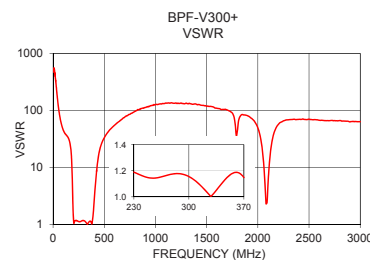
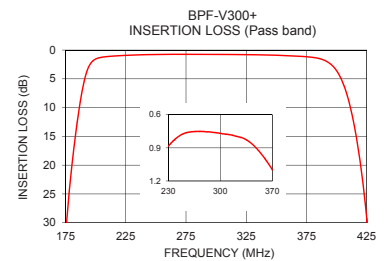
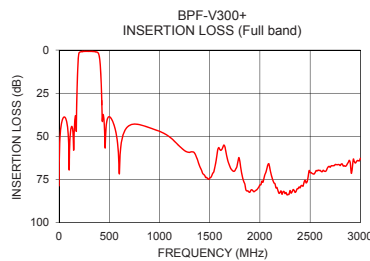

### Notes

- Performance and quality attributes and conditions not expressly stated in this specification document are intended to be excluded and do not form a part of this specification document.
- Electrical specifications and performance data contained in this specification document are based on Mini-Circuits' applicable established test performance criteria and measurement instructions.
- The parts covered by this specification document are subject to Mini-Circuits standard limited warranty and terms and conditions (collectively, "Standard Terms"); Purchasers of this part are entitled to the rights and benefits contained therein. For a full statement of the Standard Terms and the exclusive rights and remedies thereunder, please visit Mini-Circuits' website at [www.minicircuits.com/MCLStore/terms.jsp](http://www.minicircuits.com/MCLStore/terms.jsp)



## Pad Connections

INPUT	1
OUTPUT	10
GROUND	2,3,4,5,6,7,8,9,11,12,13,14,15,16

**Demo Board MCL P/N: TB-953+**  
**Suggested PCB Layout (PL-507)**

SUGGESTED MOUNTING CONFIGURATION FOR  
 KV1974 CASE STYLE, "16FL02" PIN CODE

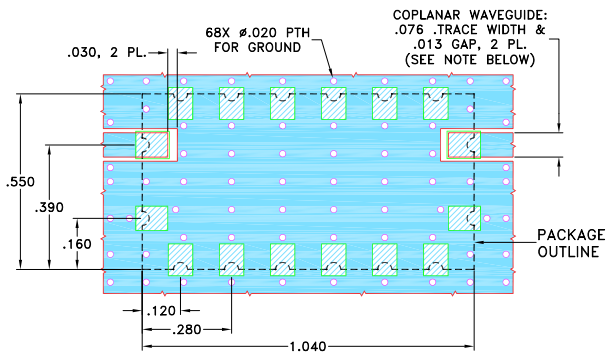

**NOTE:**

1. COPLANAR WAVEGUIDE PARAMETERS ARE SHOWN FOR ROGERS R04350B WITH DIELECTRIC THICKNESS  $.060" \pm .004"$ ; COPPER: 1/2 OZ. EACH SIDE. FOR OTHER MATERIALS TRACE WIDTH MAY NEED TO BE MODIFIED.
2. BOTTOM SIDE OF THE PCB IS CONTINUOUS GROUND PLANE.

- DENOTES PCB COPPER LAYOUT WITH SMOBC (SOLDER MASK OVER BARE COPPER)
- DENOTES COPPER LAND PATTERN FREE OF SOLDER MASK

## Outline Drawing

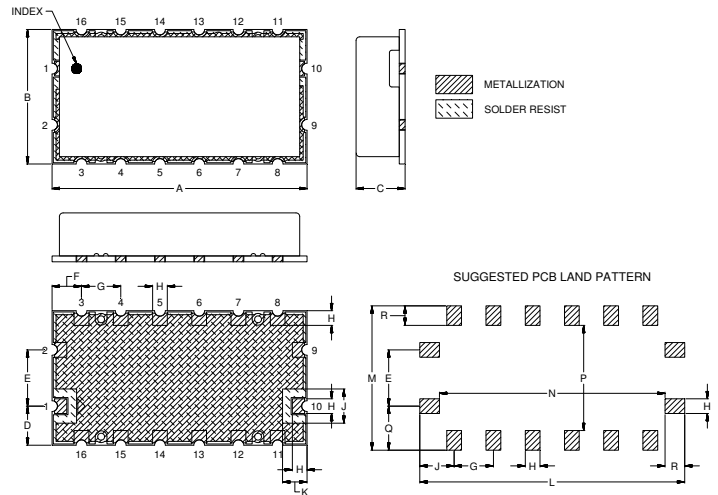

## Outline Dimensions (inch / mm)

A	B	C	D	E	F	G	H	J
1.040	.550	.200	.160	.230	.120	.160	.060	.140
26.42	13.97	5.08	4.06	5.84	3.05	4.06	1.52	3.56
K	L	M	N	P	Q	R	Wt.	
.100	1.080	.590	.920	.430	.180	.080	grams	
2.54	27.43	14.99	23.37	10.92	4.57	2.03	2	

*Note: Please refer to case style drawing for details*

**Notes**

- A. Performance and quality attributes and conditions not expressly stated in this specification document are intended to be excluded and do not form a part of this specification document.
- B. Electrical specifications and performance data contained in this specification document are based on Mini-Circuit's applicable established test performance criteria and measurement instructions.
- C. The parts covered by this specification document are subject to Mini-Circuits standard limited warranty and terms and conditions (collectively, "Standard Terms"); Purchasers of this part are entitled to the rights and benefits contained therein. For a full statement of the Standard Terms and the exclusive rights and remedies thereunder, please visit Mini-Circuits' website at [www.minicircuits.com/MCLStore/terms.jsp](http://www.minicircuits.com/MCLStore/terms.jsp)



Typical Performance Data

FREQ.  (MHz)	INSERTION LOSS			INPUT RETURN LOSS			OUTPUT RETURN LOSS		
	(dB)			(dB)			(dB)		
	@-40°C	@+25°C	@+85°C	@-40°C	@+25°C	@+85°C	@-40°C	@+25°C	@+85°C
0.3	77.84	78.59	79.03	0.04	0.04	0.04	0.06	0.05	0.06
5.0	55.38	55.47	55.43	0.04	0.03	0.04	0.04	0.04	0.04
15.0	46.09	46.11	46.12	0.03	0.04	0.04	0.04	0.04	0.04
20.0	43.80	43.83	43.82	0.04	0.04	0.05	0.04	0.04	0.05
25.0	42.17	42.17	42.15	0.05	0.05	0.06	0.04	0.04	0.05
30.0	40.94	40.93	40.93	0.05	0.06	0.07	0.05	0.05	0.06
40.0	39.39	39.38	39.36	0.08	0.10	0.11	0.06	0.07	0.08
50.0	38.81	38.79	38.77	0.12	0.14	0.15	0.08	0.09	0.11
70.0	40.28	40.32	40.35	0.20	0.24	0.27	0.14	0.17	0.19
80.0	42.86	42.96	43.01	0.25	0.30	0.32	0.18	0.22	0.24
100.0	69.30	69.41	69.31	0.33	0.39	0.42	0.29	0.35	0.39
106.0	54.17	54.10	54.09	0.36	0.41	0.44	0.34	0.40	0.44
128.0	44.04	44.28	44.54	0.41	0.47	0.50	0.52	0.60	0.66
144.0	56.30	56.71	56.96	0.44	0.51	0.56	0.69	0.80	0.87
149.0	51.12	50.16	49.34	0.45	0.53	0.58	0.76	0.87	0.94
163.0	38.07	38.05	38.03	0.53	0.63	0.71	0.97	1.12	1.22
170.0	44.37	44.78	45.20	0.61	0.74	0.84	1.12	1.29	1.41
175.0	33.41	32.46	31.46	0.73	0.88	1.00	1.27	1.47	1.62
176.0	30.36	29.58	28.71	0.76	0.92	1.05	1.30	1.52	1.67
180.0	21.08	20.58	20.00	0.97	1.17	1.33	1.52	1.78	1.98
181.0	19.15	18.70	18.16	1.05	1.26	1.43	1.60	1.88	2.10
185.0	12.35	12.07	11.69	1.64	1.93	2.18	2.19	2.57	2.90
190.0	5.86	5.83	5.69	3.89	4.34	4.77	4.40	5.02	5.61
191.0	4.91	4.93	4.85	4.72	5.20	5.66	5.23	5.89	6.55
193.0	3.42	3.53	3.53	6.91	7.41	7.92	7.39	8.16	8.95
195.0	2.44	2.60	2.66	9.85	10.33	10.83	10.30	11.18	12.13
200.0	1.38	1.56	1.67	21.66	21.52	21.34	21.86	23.73	25.84
230.0	0.77	0.88	0.96	21.75	22.36	22.32	20.63	21.27	21.53
300.0	0.65	0.77	0.85	21.87	22.23	22.00	22.70	22.83	22.31
370.0	0.92	1.10	1.22	26.34	25.81	24.90	23.89	23.23	22.79
380.0	1.07	1.27	1.41	34.61	33.99	31.66	27.96	25.97	25.42
400.0	3.18	3.60	3.98	7.79	7.92	7.83	6.58	6.44	6.20
410.0	8.14	8.81	9.47	3.87	4.21	4.43	2.51	2.59	2.58
415.0	12.73	13.56	14.42	2.90	3.24	3.47	1.62	1.76	1.81
420.0	19.16	20.14	21.25	2.26	2.55	2.74	1.22	1.38	1.47
421.0	20.72	21.73	22.89	2.16	2.44	2.61	1.17	1.34	1.43
426.0	30.52	31.66	33.17	1.73	1.96	2.09	1.05	1.22	1.32
430.0	41.05	41.17	41.26	1.47	1.67	1.77	1.01	1.18	1.28
440.0	36.94	37.47	37.82	1.04	1.20	1.27	0.97	1.15	1.25
450.0	42.41	43.23	43.92	0.81	0.94	1.00	0.97	1.15	1.26
500.0	38.34	38.64	38.90	0.44	0.52	0.56	1.03	1.21	1.35
600.0	72.96	71.72	69.50	0.25	0.32	0.35	1.01	1.18	1.32
750.0	42.76	42.89	42.95	0.14	0.20	0.24	0.87	1.04	1.14
800.0	43.06	43.21	43.27	0.12	0.18	0.22	0.90	1.07	1.18
900.0	44.89	45.01	45.07	0.10	0.15	0.19	1.04	1.26	1.45
1000.0	46.93	47.06	47.19	0.07	0.14	0.18	1.46	1.81	2.13
1250.0	57.88	58.30	58.52	0.05	0.13	0.18	2.01	2.33	2.63
1500.0	73.94	74.12	74.62	0.06	0.15	0.19	0.94	1.06	1.16
1550.0	69.12	68.12	67.15	0.06	0.15	0.19	0.76	0.88	0.99
1600.0	55.84	57.51	58.56	0.07	0.16	0.21	0.67	0.78	0.88
1700.0	65.11	67.24	68.78	0.08	0.17	0.22	0.52	0.64	0.74
1750.0	68.74	69.95	70.89	0.10	0.19	0.24	0.47	0.60	0.70
1800.0	62.03	64.45	66.88	0.37	0.40	0.38	0.44	0.57	0.67
1850.0	78.46	77.73	80.77	0.11	0.21	0.24	0.41	0.55	0.65
1900.0	80.17	82.33	81.12	0.11	0.22	0.25	0.39	0.53	0.63
2000.0	79.00	78.14	78.80	0.23	0.35	0.41	0.37	0.50	0.60
2250.0	82.98	83.14	84.25	0.16	0.26	0.29	0.37	0.49	0.58
2500.0	70.69	71.01	69.38	0.15	0.25	0.27	0.39	0.48	0.57
2750.0	65.87	66.31	65.37	0.17	0.26	0.27	0.38	0.47	0.55
3000.0	61.86	62.75	61.09	0.17	0.27	0.28	0.38	0.46	0.53

*Typical Performance Data*

FREQ.  (MHz)	GROUP DELAY		
	(nsec)		
	@-40°C	@+25°C	@+85°C
230.0	7.32	7.29	7.26
231.0	7.22	7.19	7.16
232.0	7.12	7.09	7.06
233.0	7.02	7.00	6.98
234.0	6.94	6.92	6.90
235.0	6.85	6.83	6.81
236.0	6.77	6.75	6.74
237.0	6.69	6.67	6.66
238.0	6.62	6.60	6.59
239.0	6.53	6.52	6.51
240.0	6.44	6.43	6.42
241.0	6.39	6.38	6.37
242.0	6.34	6.33	6.32
243.0	6.29	6.28	6.27
244.0	6.24	6.23	6.22
245.0	6.18	6.17	6.16
246.0	6.13	6.12	6.12
247.0	6.07	6.07	6.06
248.0	6.02	6.02	6.01
249.0	5.98	5.97	5.97
250.0	5.93	5.92	5.91
255.0	5.72	5.71	5.71
260.0	5.55	5.54	5.54
265.0	5.41	5.40	5.40
270.0	5.29	5.28	5.27
275.0	5.19	5.18	5.18
280.0	5.11	5.10	5.10
285.0	5.04	5.03	5.03
290.0	4.99	4.99	4.99
295.0	4.96	4.96	4.96
300.0	4.95	4.96	4.96
305.0	4.96	4.97	4.98
310.0	4.99	5.01	5.02
315.0	5.04	5.06	5.08
320.0	5.11	5.13	5.15
325.0	5.19	5.21	5.23
330.0	5.29	5.31	5.34
335.0	5.41	5.43	5.46
340.0	5.55	5.57	5.60
345.0	5.71	5.74	5.76
350.0	5.92	5.94	5.97
352.0	6.01	6.03	6.06
353.0	6.06	6.08	6.11
354.0	6.11	6.14	6.17
355.0	6.16	6.19	6.22
356.0	6.22	6.24	6.28
357.0	6.27	6.30	6.34
358.0	6.32	6.35	6.39
359.0	6.37	6.41	6.44
360.0	6.42	6.45	6.50
361.0	6.52	6.55	6.60
362.0	6.61	6.64	6.69
363.0	6.68	6.72	6.77
364.0	6.76	6.80	6.86
365.0	6.85	6.89	6.96
366.0	6.94	6.99	7.05
367.0	7.03	7.09	7.15
368.0	7.13	7.19	7.26
369.0	7.24	7.30	7.38
370.0	7.35	7.41	7.49

## Typical Performance Curves

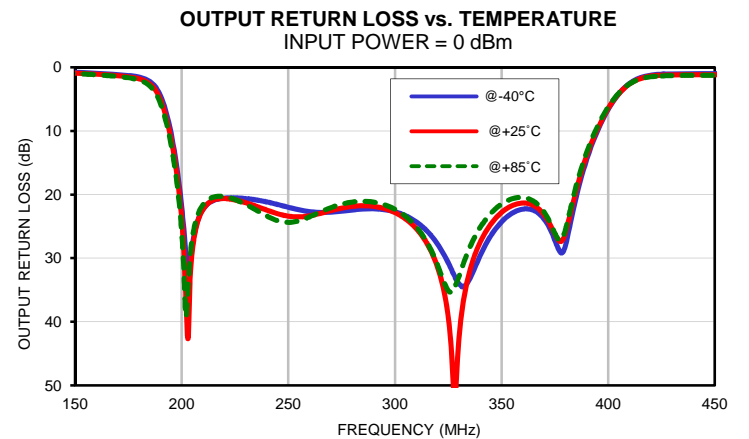
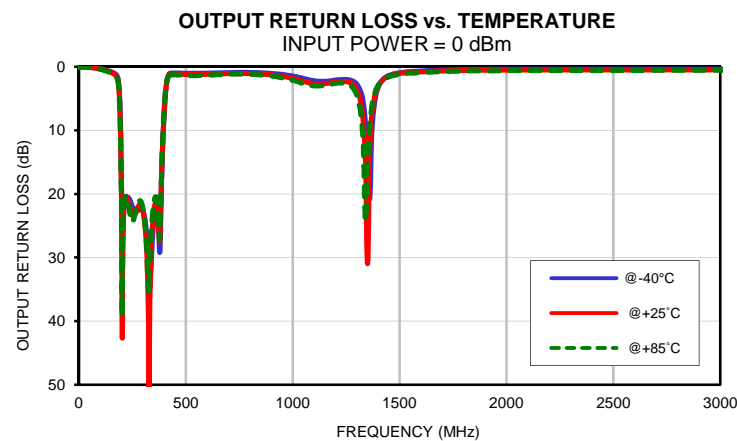
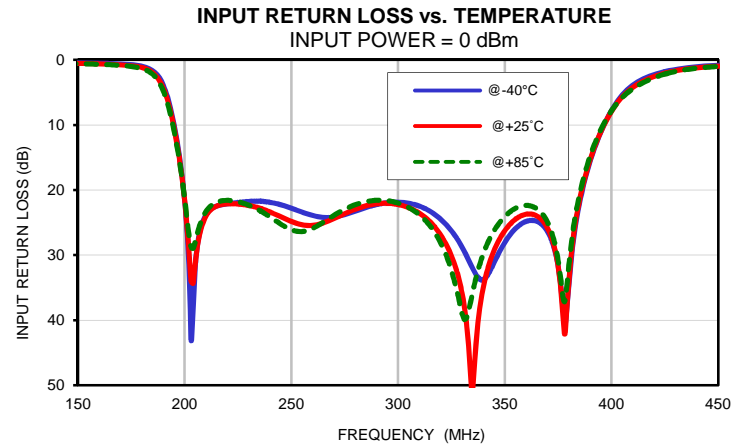
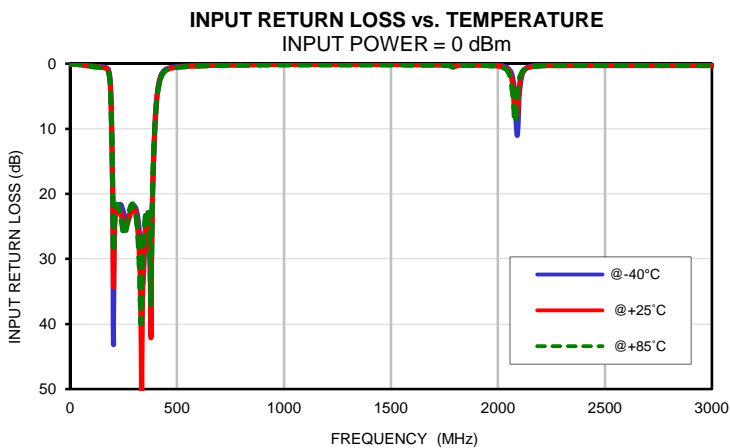
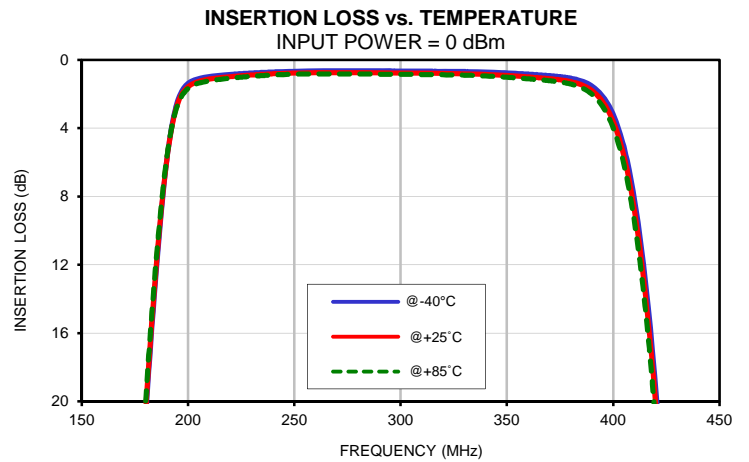
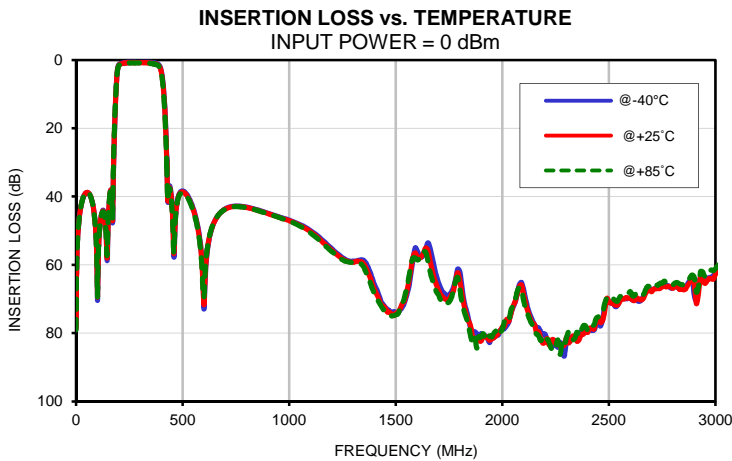

## Typical Performance Curves

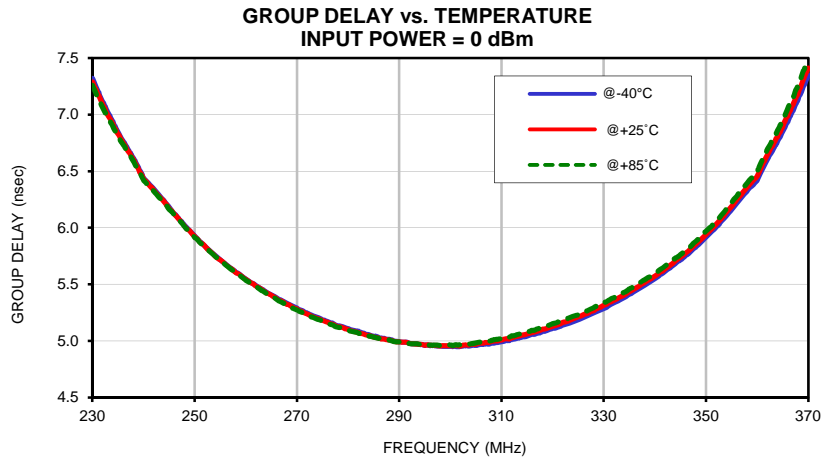

### Outline Dimensions

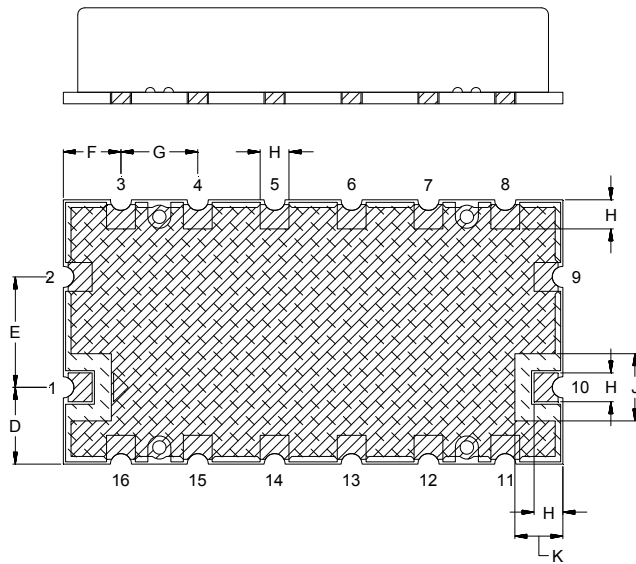
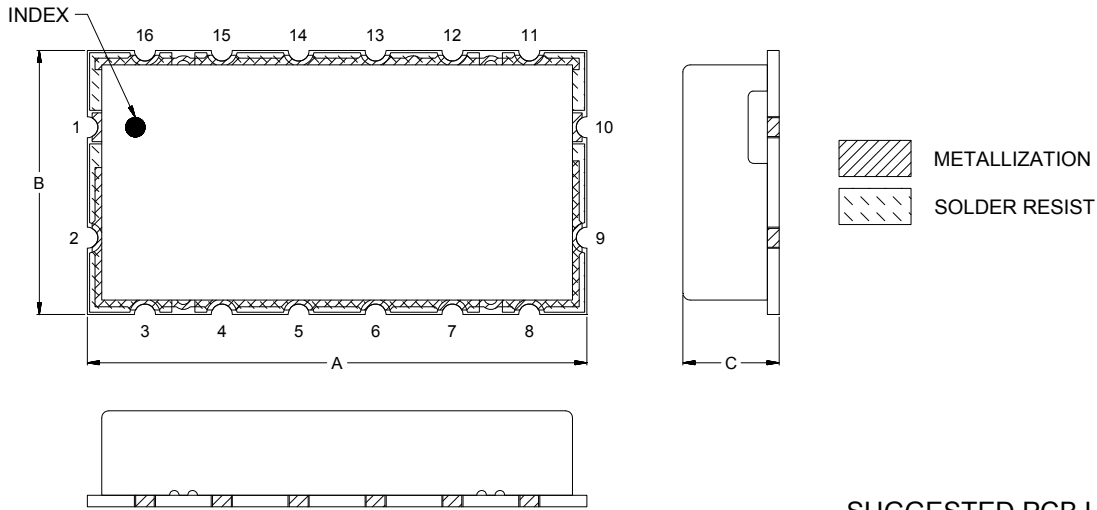

### SUGGESTED PCB LAND PATTERN

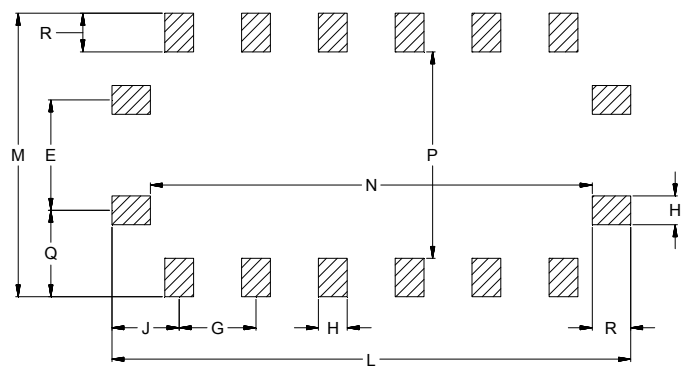

CASE#	A	B	C	D	E	F	G	H	J	K	L	M
KV1974	1.040 (26.42)	.550 (13.97)	.200 (5.08)	.160 (4.06)	.230 (5.84)	.120 (3.05)	.160 (4.06)	.060 (1.52)	.140 (3.56)	.100 (2.54)	1.080 (27.43)	.590 (14.99)

CASE#	N	P	Q	R	WT. GRAM
KV1974	.920 (23.37)	.430 (10.92)	.180 (4.57)	.080 (2.03)	2

Dimensions are in inches (mm). Tolerances: 2PL.  $\pm .03$ ; 3PL.  $\pm .015$

### Notes:

- Case material: Nickel-Silver alloy.
- Base: Printed wiring laminate.
- Termination finish:
  - For RoHS Case Styles: 3-5  $\mu$  inch (.08-.13 microns) Gold over 120-240  $\mu$  inch (3.05-6.10 microns) Nickel plate.
  - For RoHS-5 Case Styles: Tin-Lead plate.



P.O. Box 350166, Brooklyn, New York 11235-0003 (718) 934-4500 Fax (718) 332-4661 For detailed performance specs & shopping online see Mini-Circuits web site



The Design Engineers Search Engine Provides ACTUAL Data Instantly From MINI-CIRCUITS At: [www.minicircuits.com](http://www.minicircuits.com)

RF/IF MICROWAVE COMPONENTS



# Tape & Reel Packaging TR-F106

## DEVICE ORIENTATION IN T&R

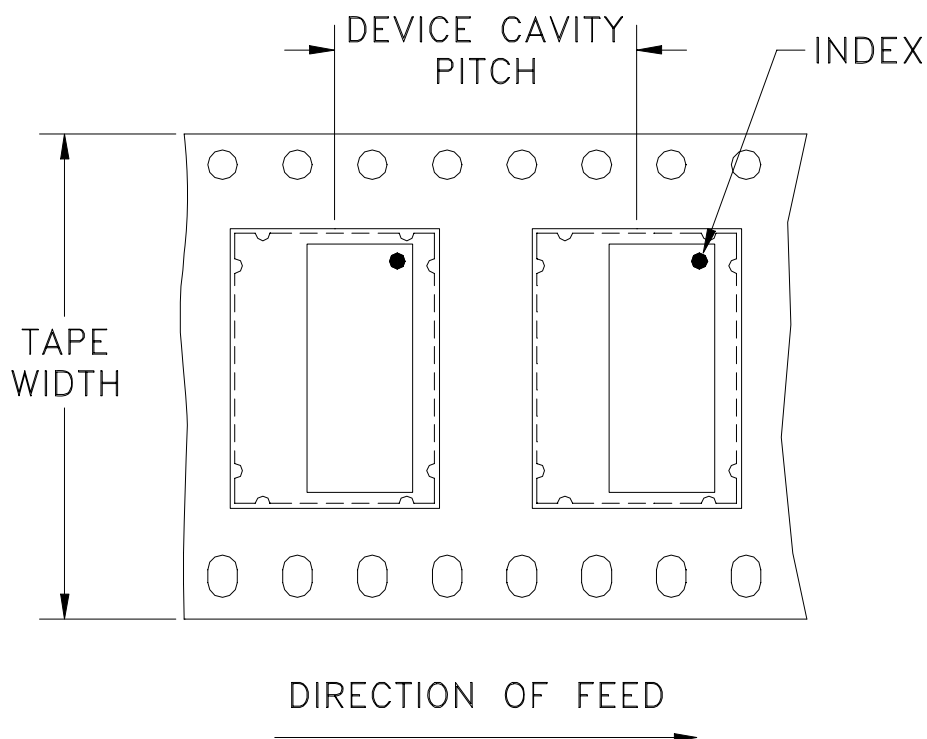

Tape Width, mm	Device Cavity Pitch, mm	Reel Size, inches	Devices per Reel
44	24	13	250

Mini-Circuits carrier tape materials provide protection from ESD (Electro-Static Discharge) during handling and transportation. Tapes are static dissipative and comply with industry standards EIA-481/EIA-541.

Go to: [www.minicircuits.com/pages/pdfs/tape.pdf](http://www.minicircuits.com/pages/pdfs/tape.pdf)



INTERNET <http://www.minicircuits.com>

P.O. Box 350166, Brooklyn, New York 11235-0003 (718) 934-4500 Fax (718) 332-4661

Distribution Centers NORTH AMERICA 800-654-7949 • 417-335-5935 • Fax 417-335-5945 • EUROPE 44-1252-832600 • Fax 44-1252-837010

Mini-Circuits ISO 9001 & ISO 14001 Certified

THIRD ANGLE PROJECTION

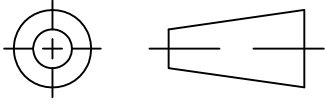

REVISIONS

REV	ECN No.	DESCRIPTION	DATE	DR	AUTH
OR	M160945	NEW RELEASE	MAR 17	TM	MD

SUGGESTED MOUNTING CONFIGURATION FOR  
KV1974 CASE STYLE, "16FL02" PIN CODE

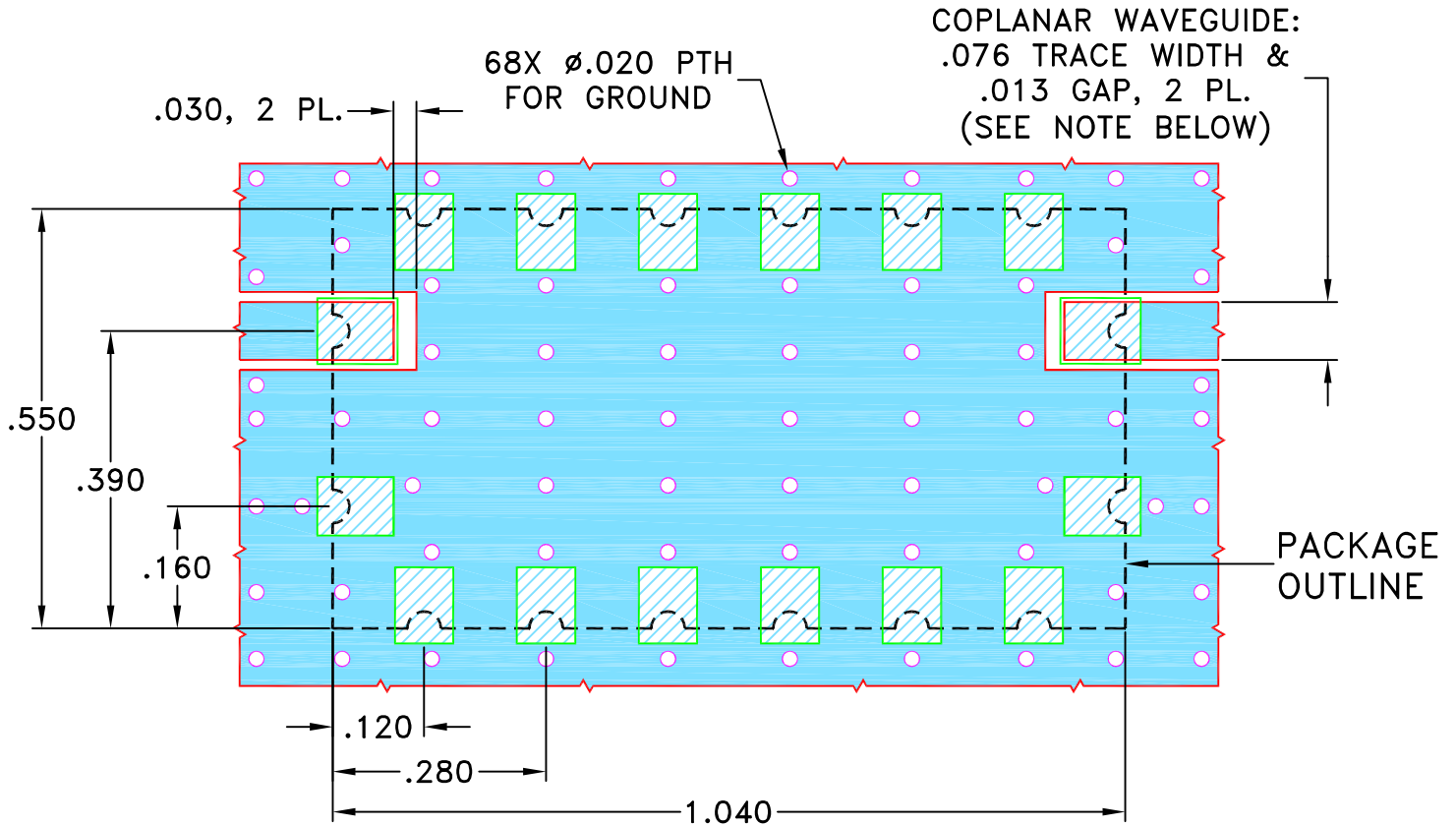

NOTE:

1. COPLANAR WAVEGUIDE PARAMETERS ARE SHOWN FOR ROGERS RO4350B WITH DIELECTRIC THICKNESS .060" ± .004"; COPPER: 1/2 OZ. EACH SIDE. FOR OTHER MATERIALS TRACE WIDTH MAY NEED TO BE MODIFIED.
2. BOTTOM SIDE OF THE PCB IS CONTINUOUS GROUND PLANE.

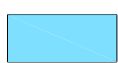

DENOTES PCB COPPER LAYOUT WITH SMOBC (SOLDER MASK OVER BARE COPPER)



DENOTES COPPER LAND PATTERN FREE OF SOLDER MASK

UNLESS OTHERWISE SPECIFIED	INITIALS	DATE
DRAWN	TM	24 MAR 17
CHECKED	MD	24 MAR 17
APPROVED	MD	24 MAR 17



Mini-Circuits®

13 Neptune Avenue  
Brooklyn NY 11235

PL, 16FL02, KV1974, TB-953+

Mini-Circuits®  
THIS DOCUMENT AND ITS CONTENTS ARE THE PROPERTY OF MINI-CIRCUITS. EXCEPT FOR USE EXPRESSLY GRANTED, IN WRITING, TO ITS VENDORS, VENDEE AND THE UNITED STATES GOVERNMENT, MINI-CIRCUITS RESERVES ALL PROPRIETARY DESIGN, USE, MANUFACTURING AND REPRODUCTION RIGHTS THERETO. THESE CONTENTS SHALL NOT BE USED, DUPLICATED OR DISCLOSED TO ANY OUTSIDE PARTY, IN WHOLE OR IN PART, WITHOUT WRITTEN PERMISSION OF MINI-CIRCUITS.

SIZE	CODE IDENT	DRAWING NO:	REV:
A	15542	98-PL-507	OR
FILE:	98PL507	SCALE:	4:1
SHEET:	1	OF	1

# Evaluation Board and Circuit

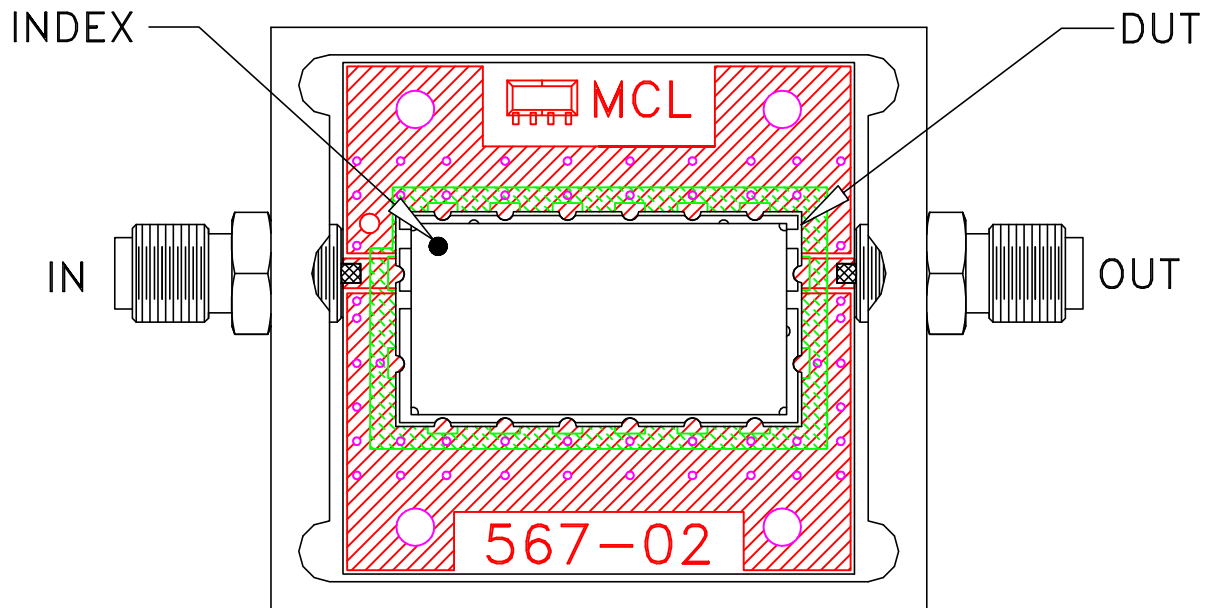

TB-953+

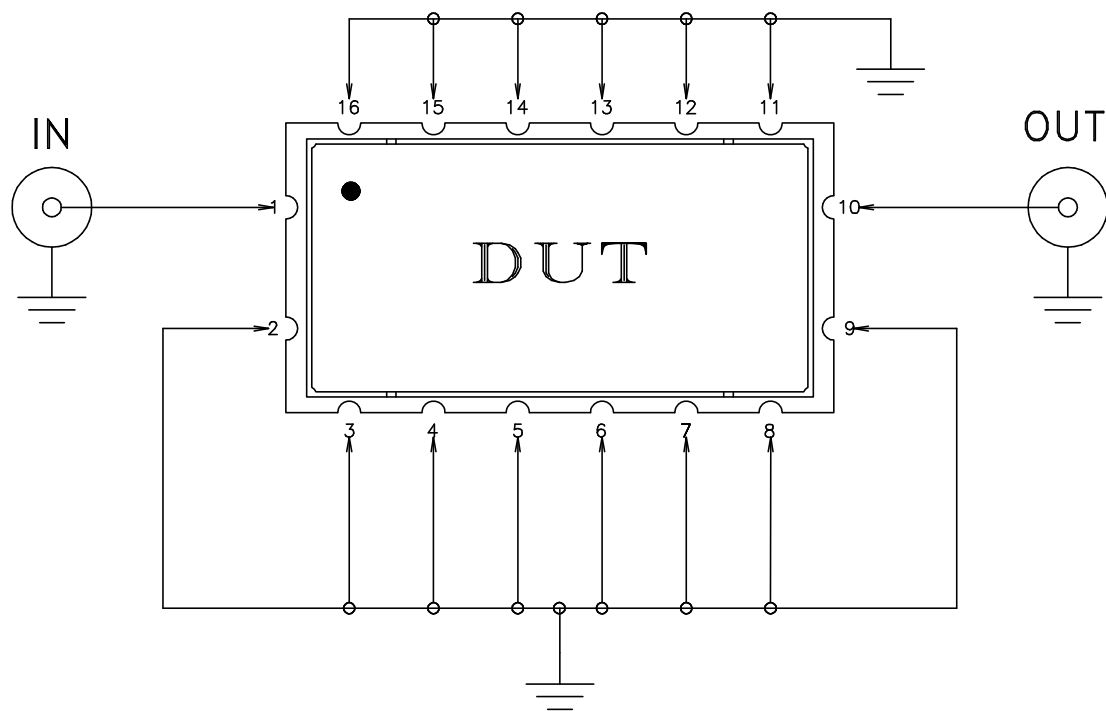

Schematic Diagram

**Notes:**

1. 50 Ohm SMA Female connectors.
2. PCB Material: R04350 or equivalent,  
Dielectric Constant=3.5, Thickness=.060 inch.

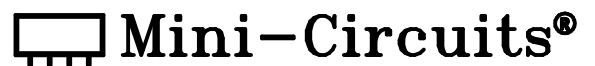

All Mini-Circuits products are manufactured under exacting quality assurance and control standards, and are capable of meeting published specifications after being subjected to any or all of the following physical and environmental test.

Specification	Test/Inspection Condition	Reference/Spec
Operating Temperature	-40° to 85°C Ambient Environment	Individual Model Data Sheet
Storage Temperature	-55° to 100° C Ambient Environment	Individual Model Data Sheet
Humidity	90 to 95% RH, 240 hours, 50°C	MIL-STD-202, Method 103, Condition A, Except 50°C and end-point electrical test done within 12 hours
Thermal Shock	-55° to 100°C, 100 cycles	MIL-STD-202, Method 107, Condition A-3, except +100°C
Solder Reflow Heat	Sn-Pb Eutetic Process: 225°C peak Pb-Free Process 245° - 250°C peak	J-STD-020, Table 4-1, 4-2 and 5-2, Figure 5-1
Solderability	10X Magnification	J-STD-002, 95% Coverage
Vibration (High Frequency)	20g peak, 10-2000 Hz, 12 times in each of three perpendicular directions (total 36)	MIL-STD-202, Method 204, Condition D
Mechanical Shock	50g, 11 ms, 1/2-sine, 18 shocks: 3 each direction, each of 3 axes	MIL-STD-202, Method 213, Condition A
Marking Resistance to Solvents	Isopropyl alcohol + mineral spirits at 25°C; terpene defluxer at 25°C; distilled water + proylene glycol monomethyl ether + monoethanolamine at 63°C to 70°C	MIL-STD-202, Method 215