

Engineering Development Model

Power Splitter/Combiner

CDP-ED14964/1

2 Way-0°

Important Note

This model has been designed, built and tested in our engineering department. Performance data represents model capability. At present it is a non-catalog model. On request, we can supply a final specification sheet, part number and price/delivery information.

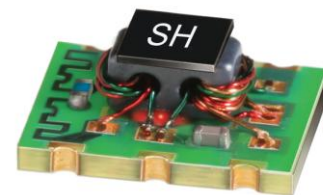

Please click "Back", and then click "Contact Us" for Applications support.

CASE STYLE : TT1491-2

ELECTRICAL SPECIFICATIONS 75Ω @ +25°C					
Parameter		Min.	Typ.	Max.	Units
Frequency		0.5		1600	MHz
Isolation	0.5-5 MHz		19		dB
	5-800 MHz		27		dB
	800-1500 MHz		21		dB
Insertion Loss Above 3.0 dB	0.5-5 MHz		0.7		dB
	5-800 MHz		0.5		dB
	800-1500 MHz		1.5		dB
Phase Unbalance	0.5-5 MHz		3.0		deg.
	5-800 MHz		1.0		deg.
	800-1500 MHz		1.0		deg.
Amplitude Unbalance	0.5-5 MHz		0.50		dB
	5-800 MHz		0.25		dB
	800-1500 MHz		0.30		dB
VSWR	SUM Port		1.10		(:1)
	OUT Ports		1.20		(:1)

MAXIMUM RATINGS	
Operating Temperature	-40°C to 85°C
Storage Temperature	-55°C to 100°C

PIN CONNECTIONS	
SUM PORT	6
PORT 1	4
PORT 2	3
GND EXT	1
NOT CONNECTED	2,5

Functional Diagram



REV. X1

CDP-ED14964/1

5/2/2013

Page 1 of 1

2 Way-0° Power Splitter/Combiner

CDP-ED14964/1

Typical Performance Data

FREQ. (MHz)	TOTAL LOSS ¹ (dB)		AMP. UNBAL. (dB)	ISOLATION (dB)	PHASE UNBAL. (Deg.)	FREQ. (MHz)	VSWR (:1)		
	S-1	S-2					S	1	2
0.5	3.70	3.19	0.51	16.05	3.03	0.5	1.20	1.82	1.57
0.7	3.65	3.22	0.43	17.85	2.39	0.7	1.16	1.63	1.44
1.0	3.60	3.23	0.38	19.50	1.87	1.0	1.12	1.51	1.36
2.0	3.52	3.20	0.32	22.22	1.22	2.0	1.09	1.36	1.26
3.0	3.47	3.18	0.28	23.82	1.02	3.0	1.07	1.30	1.21
4.0	3.43	3.17	0.26	25.12	0.88	4.0	1.06	1.26	1.18
5.0	3.40	3.16	0.24	26.22	0.78	5.0	1.05	1.23	1.16
6.0	3.38	3.15	0.23	27.14	0.68	6.0	1.05	1.21	1.15
10.0	3.36	3.14	0.21	29.60	0.45	10.0	1.03	1.17	1.12
20.0	3.34	3.15	0.19	32.00	0.24	20.0	1.02	1.14	1.09
30.0	3.34	3.15	0.19	32.47	0.14	30.0	1.02	1.14	1.09
40.0	3.35	3.16	0.19	32.37	0.08	40.0	1.02	1.13	1.09
50.0	3.35	3.17	0.19	32.11	0.05	50.0	1.02	1.13	1.09
60.0	3.36	3.17	0.19	31.82	0.01	60.0	1.02	1.13	1.09
70.0	3.37	3.18	0.19	31.56	0.01	70.0	1.02	1.13	1.09
80.0	3.38	3.18	0.19	31.31	0.02	80.0	1.02	1.13	1.09
90.0	3.38	3.19	0.19	31.09	0.03	90.0	1.02	1.13	1.09
100.0	3.39	3.20	0.19	30.90	0.04	100.0	1.02	1.13	1.09
200.0	3.44	3.24	0.20	29.47	0.07	200.0	1.02	1.11	1.09
300.0	3.48	3.29	0.19	28.47	0.06	300.0	1.04	1.10	1.09
400.0	3.53	3.35	0.18	27.49	0.03	400.0	1.05	1.07	1.09
500.0	3.59	3.41	0.18	26.47	0.02	500.0	1.06	1.05	1.10
600.0	3.64	3.48	0.16	25.22	0.12	600.0	1.06	1.04	1.10
700.0	3.69	3.54	0.15	24.31	0.24	700.0	1.06	1.05	1.11
800.0	3.76	3.63	0.14	23.47	0.40	800.0	1.06	1.08	1.12
870.0	3.82	3.69	0.13	22.88	0.56	870.0	1.06	1.10	1.13
900.0	3.85	3.73	0.12	22.68	0.64	900.0	1.06	1.11	1.13
950.0	3.90	3.78	0.11	22.35	0.78	950.0	1.06	1.13	1.14
1002.0	3.95	3.84	0.11	22.03	0.94	1002.0	1.07	1.15	1.15
1050.0	4.00	3.90	0.10	21.80	1.10	1050.0	1.08	1.16	1.16
1100.0	4.06	3.96	0.09	21.58	1.27	1100.0	1.10	1.19	1.17
1150.0	4.12	4.03	0.09	21.40	1.48	1150.0	1.11	1.20	1.18
1200.0	4.19	4.10	0.09	21.23	1.71	1200.0	1.13	1.22	1.19
1250.0	4.26	4.18	0.09	21.05	1.94	1250.0	1.15	1.23	1.20
1300.0	4.35	4.26	0.09	20.83	2.21	1300.0	1.17	1.25	1.20
1400.0	4.54	4.44	0.10	20.10	2.78	1400.0	1.23	1.26	1.21
1500.0	4.80	4.67	0.13	18.68	3.40	1500.0	1.33	1.26	1.18
1600.0	5.16	4.98	0.18	16.59	4.09	1600.0	1.48	1.23	1.14

¹Total Loss = Insertion Loss + 3dB Splitter Loss



Typical Performance Curves

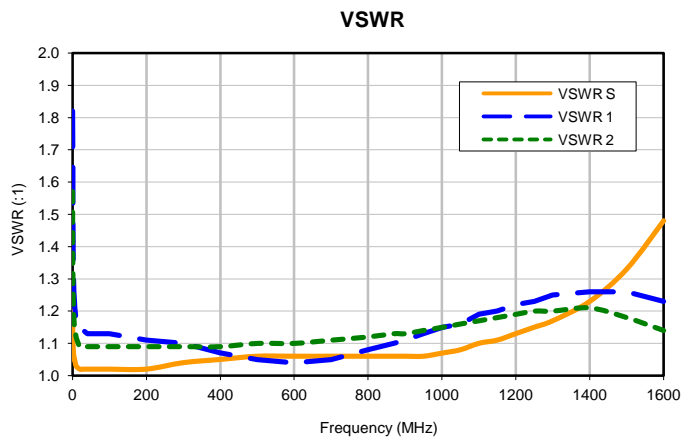
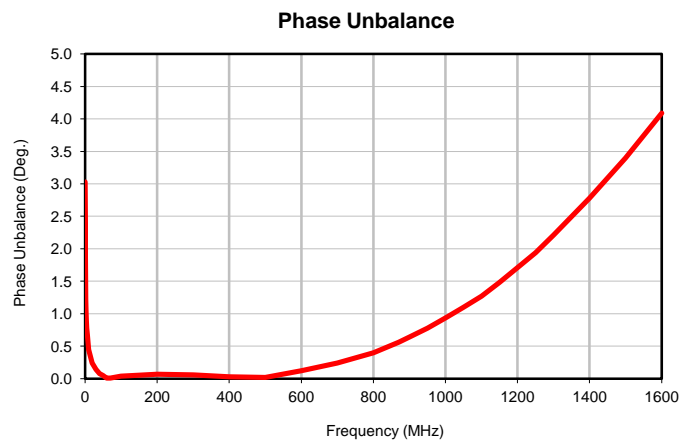
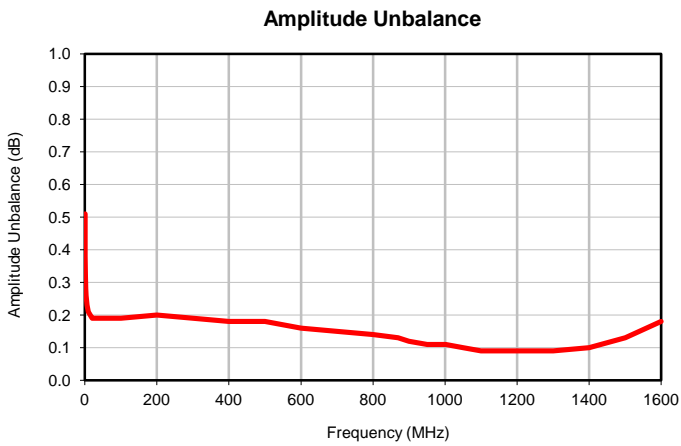
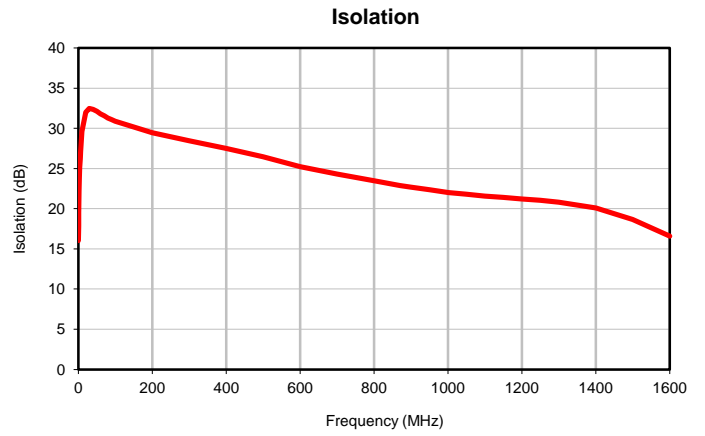
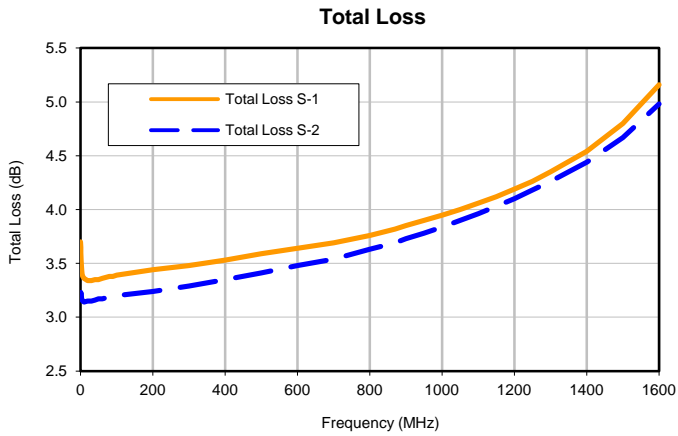

Outline Dimensions

TT1491-2

PCB Land Pattern

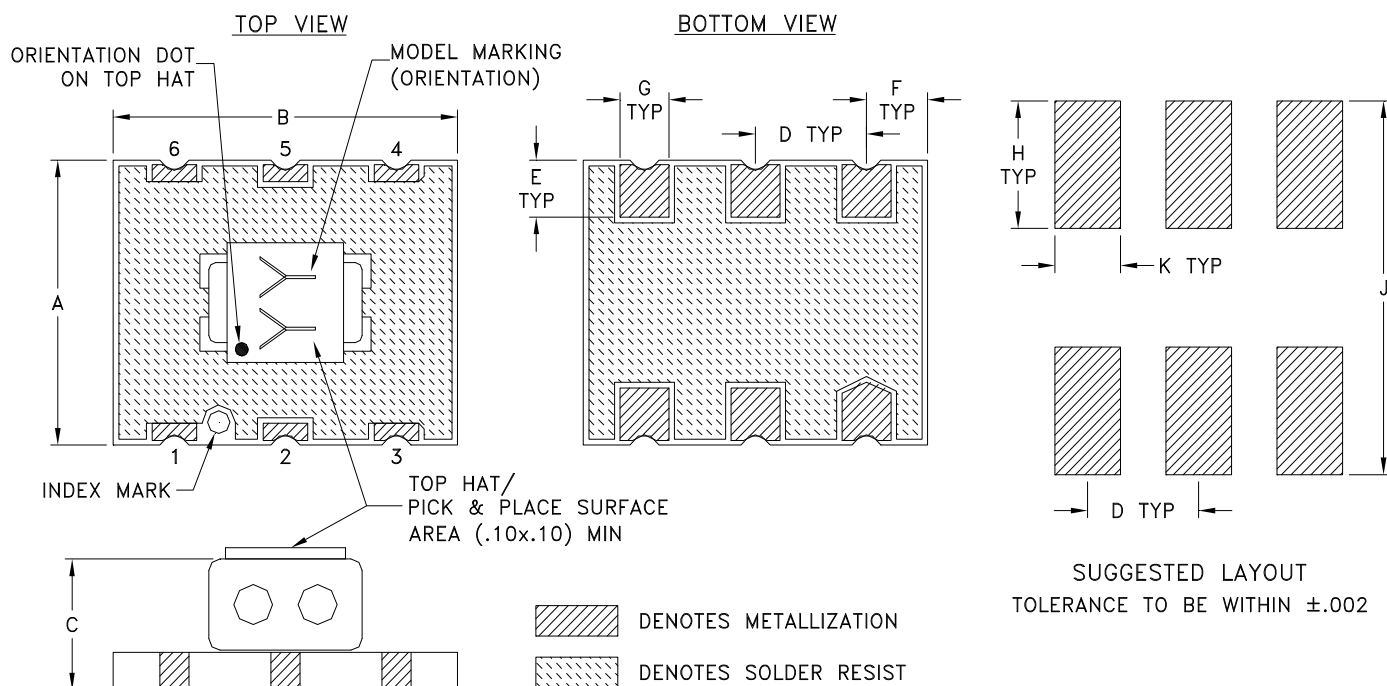

CASE #	A	B	C	D	E	F	G	H	J	K	WT GRAMS
TT1491-2	.250 (6.35)	.310 (7.87)	.133 (3.38)	.100 (2.54)	.050 (1.27)	.055 (1.40)	.044 (1.12)	.112 (2.84)	.328 (8.33)	.059 (1.50)	.35

Dimensions are in inches (mm). Tolerances: 2Pl. $\pm .01$; 3 Pl. $\pm .005$

Notes:

- Open style, Base material: Printed wiring laminate.
- Termination finish: 3-5 μ inch (.08-.13 microns) Gold over 120-240 μ inch (3.05-6.10 microns) Nickel plate.
All models, (+) suffix.
- Top-Hat total thickness: .013 inches MAX.
- Orientation Dot on Top Hat & PCB corresponds to Pin #1.



P.O. Box 350166, Brooklyn, New York 11235-0003 (718) 934-4500 Fax (718) 332-4661 For detailed performance specs & shopping online see Mini-Circuits web site



The Design Engineers Search Engine Provides ACTUAL Data Instantly From MINI-CIRCUITS At: www.minicircuits.com

RF/IF MICROWAVE COMPONENTS

Tape & Reel Packaging TR-F2

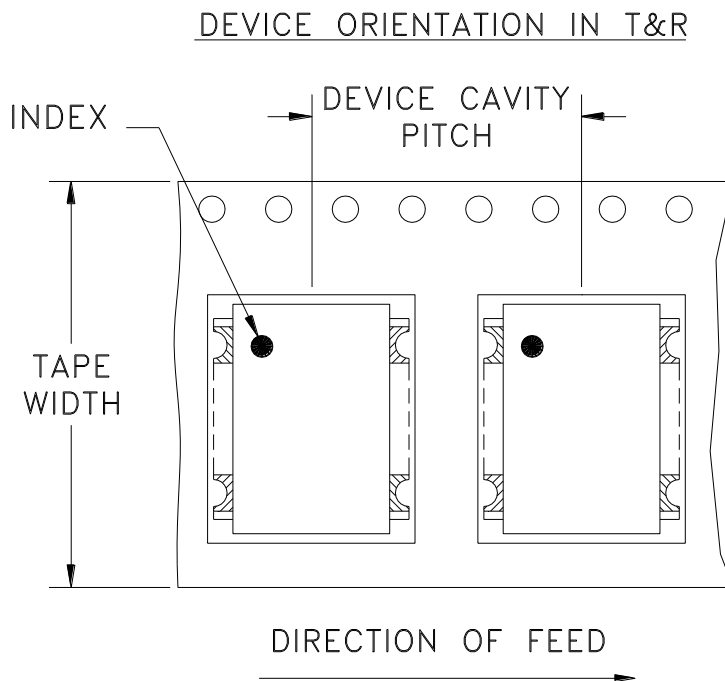

Tape Width, mm	Device Cavity Pitch, mm	Reel Size, inches	Devices per Reel See note
16	12	7	10
			20
			50
			100
		200	
		13	500

Note: Please consult individual model data sheet to determine device per reel availability

Mini-Circuits carrier tape materials provide protection from ESD (Electro-Static Discharge) during handling and transportation. Tapes are static dissipative and comply with industry standards EIA-481/EIA-541.

Go to: www.minicircuits.com/pages/pdfs/tape.pdf



INTERNET <http://www.minicircuits.com>

P.O. Box 350166, Brooklyn, New York 11235-0003 (718) 934-4500 Fax (718) 332-4661

Distribution Centers NORTH AMERICA 800-654-7949 • 417-335-5935 • Fax 417-335-5945 • EUROPE 44-1252-832600 • Fax 44-1252-837010

Mini-Circuits ISO 9001 & ISO 14001 Certified

Evaluation Board and Circuit

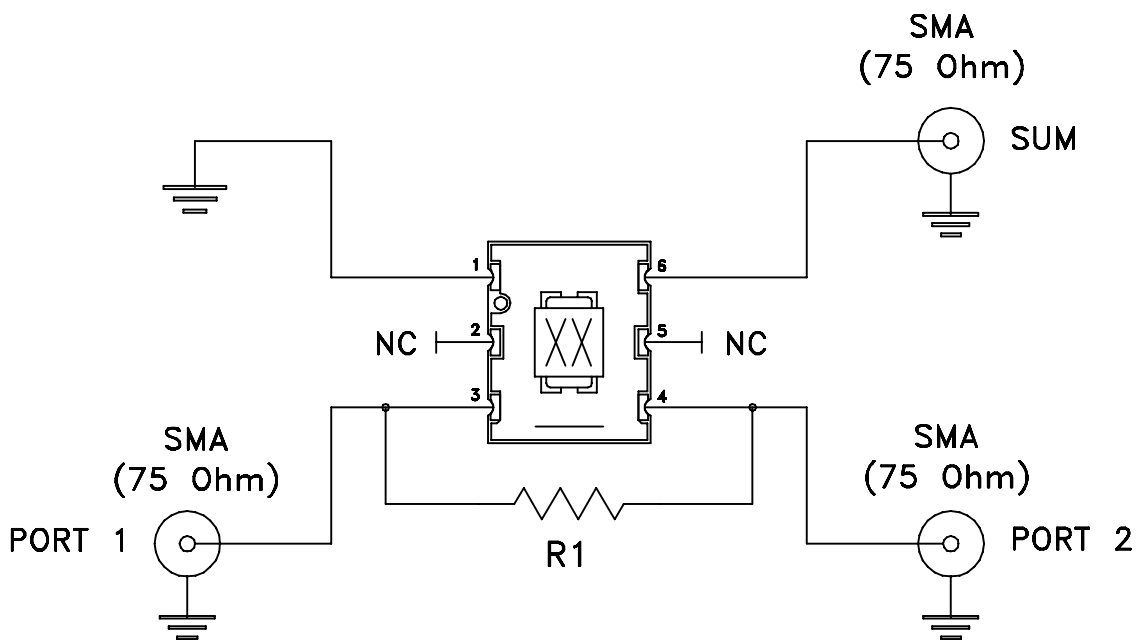
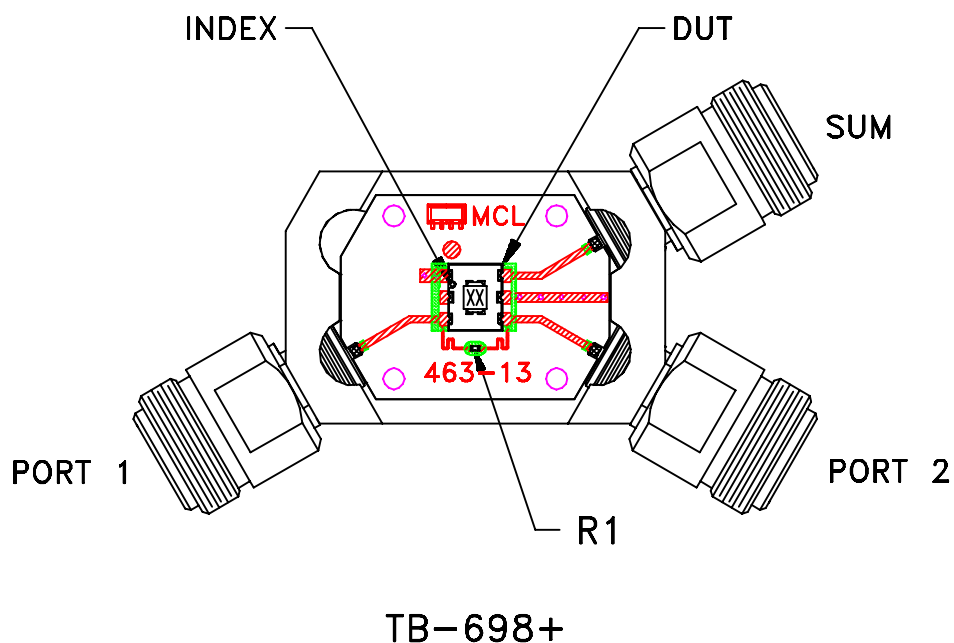

Schematic Diagram

Notes:

1. 75 Ohm SMA Female connectors.
2. PCB Material: R04350 or equivalent,
Dielectric Constant=3.5, Thickness=.030 inch.

 **Mini-Circuits®**

All Mini-Circuits products are manufactured under exacting quality assurance and control standards, and are capable of meeting published specifications after being subjected to any or all of the following physical and environmental test.

Specification	Test/Inspection Condition	Reference/Spec
Operating Temperature	-40° to 85°C Ambient Environment	Individual Model Data Sheet
Storage Temperature	-55° to 100° C Ambient Environment	Individual Model Data Sheet
Humidity	90 to 95% RH, 240 hours, 50°C	MIL-STD-202, Method 103, Condition A, Except 50°C and end-point electrical test done within 12 hours
Thermal Shock	-55° to 100°C, 100 cycles	MIL-STD-202, Method 107, Condition A-3, except +100°C
Solder Reflow Heat	Sn-Pb Eutetic Process: 225°C peak Pb-Free Process 245° - 250°C peak	J-STD-020, Table 4-1, 4-2 and 5-2, Figure 5-1
Solderability	10X Magnification	J-STD-002, 95% Coverage
Vibration (High Frequency)	20g peak, 10-2000 Hz, 12 times in each of three perpendicular directions (total 36)	MIL-STD-202, Method 204, Condition D
Mechanical Shock	50g, 11 ms, 1/2-sine, 18 shocks: 3 each direction, each of 3 axes	MIL-STD-202, Method 213, Condition A
Marking Resistance to Solvents	Isopropyl alcohol + mineral spirits at 25°C; terpene defluxer at 25°C; distilled water + proylene glycol monomethyl ether + monoethanolamine at 63°C to 70°C	MIL-STD-202, Method 215