



ULTRA-LINEAR LOW NOISE

# Monolithic Amplifier

## CMA-103+

50Ω 0.05 to 4 GHz

### THE BIG DEAL

- Ceramic, Hermetically Sealed, High Reliability
- Low Profile Case, 0.045" High
- +5 V/+3 V Operation
- High IP3, +45 dBm Typ. at 2 GHz,  $V_d = +5$  V
- Low Noise Figure, 0.5 dB Typ. at 1 GHz; 0.8 dB Typ. at 2 GHz
- Gain, 10.9 dB Typ. at 2 GHz
- P1dB, +23.1 dBm Typ. at 2 GHz at  $V_d = +5$  V
- Small Size, 3x3x1.14 mm



Generic photo used for illustration purposes only

CASE STYLE: DL1721

### +RoHS Compliant

The +Suffix identifies RoHS Compliance. See our website for methodologies and qualifications

MIL SCREENING AVAILABLE  
PLEASE CONSULT APPLICATIONS DEPT.

### APPLICATIONS

- High Rel Systems
- Defense and Aerospace
- Base Station Infrastructure
- Portable Wireless
- CATV & DBS
- MMDS & Wireless LAN
- LTE

### PRODUCT OVERVIEW

Mini-Circuits' CMA-103+ is an advanced wideband amplifier fabricated using E-pHEMT technology and offers extremely high dynamic range over a broad frequency range and with low noise figure. In addition, the CMA-103+ has good input and output return loss over a broad frequency range without the need for external matching components and has demonstrated excellent reliability. The amplifier is bonded to a multilayer integrated LTCC substrate, then hermetically sealed under a controlled Nitrogen atmosphere with gold-plated cover, eutectic Au-Sn solder, and Ni-Pd-Au termination finish. CMA-series amplifiers are capable of meeting MIL requirements for gross leak, fine leak, thermal shock, vibration, acceleration, mechanical shock, and HTOL. The testing can be done if requested.

### KEY FEATURES

Feature	Advantages
Hermetically Sealed	Ideal for use anywhere long-term reliability adds bottom-line value: high moisture areas, busy production lines, high-speed distribution centers, heavy industry, outdoor settings, and unmanned facilities, as well as military applications.
Broad Band: 0.05 to 4.0 GHz	Broadband covering primary wireless communications bands: Cellular, PCS, LTE, WiMAX
Ultra High IP3 vs. DC Power Consumption: +45 dBm Typical at 2 GHz at +5 V Supply Voltage and Only 97 mA	The CMA-103+ provides excellent IP3 performance relative to device size and power consumption. The combination of the design and E-pHEMT Structure provides enhanced linearity over a broad frequency range as evidence in the IP3 being typically 20 dB above the P1dB point. This feature makes this amplifier ideal for use in: <ul style="list-style-type: none"> <li>• Driver amplifiers for complex waveform up converter paths</li> <li>• Drivers in linearized transmit systems</li> <li>• Secondary amplifiers in ultra High Dynamic range receivers</li> </ul>
Low Noise Figure: 0.5 dB up to 1.0 GHz	A unique feature of the CMA-103+ which separates this design from all competitors is the low noise figure performance in combination with the high dynamic range.
Ceramic, Hermetic Package	Low inductance, repeatable performance, outstanding reliability in tough operating conditions, and small size (3x3x1.14 mm)

REV. C  
ECO-025417  
CMA-103+  
MCL NY  
260423





ULTRA-LINEAR LOW NOISE

# Monolithic Amplifier

**CMA-103+**

50Ω 0.05 to 4 GHz

**ELECTRICAL SPECIFICATIONS<sup>1</sup> AT +25°C AND 50Ω UNLESS NOTED OTHERWISE**

Parameter	Condition (GHz)	V <sub>d</sub> =+5 V			V <sub>d</sub> =+3 V	Units
		Min.	Typ.	Max.	Typ.	
Frequency Range		0.05		4.0		GHz
Gain	0.05	-	26.3	-	25.7	dB
	0.4	-	22.1	-	21.7	
	1.0	14.7	16.3	18.0	16.0	
	2.0	-	11.0	-	10.7	
	3.0	-	7.9	-	7.7	
	4.0	-	5.8	-	5.7	
Noise Figure	0.05	-	0.4	-	0.3	dB
	0.4	-	0.4	-	0.4	
	1.0	-	0.5	-	0.4	
	2.0	-	0.8	-	0.9	
	3.0	-	1.1	-	0.8	
	4.0	-	1.3	-	1.3	
Input Return Loss	0.05	-	6.2	-	5.8	dB
	0.4	-	10.9	-	10.2	
	1.0	10.0	14.0	-	13.0	
	2.0	-	16.0	-	15.0	
	3.0	-	17.3	-	16.4	
	4.0	-	18.6	-	17.3	
Output Return Loss	0.05	-	12.9	-	13.0	dB
	0.4	-	19.9	-	21.8	
	1.0	14.0	18.2	-	22.1	
	2.0	-	16.4	-	19.9	
	3.0	-	15.2	-	18.2	
	4.0	-	14.5	-	17.1	
Reverse Isolation	1.0	-	+21.1	-	+20.3	dBm
Output Power @ 1 dB Compression <sup>2</sup>	0.05	-	+20.0	-	+15.6	dBm
	0.4	-	+22.1	-	+18.6	
	1.0	-	+22.2	-	+18.9	
	2.0	-	+23.1	-	+19.7	
	3.0	-	+23.5	-	+20.3	
	4.0	-	+24.2	-	+20.9	
Output IP3	0.05	-	+37.4	-	+34.9	dBm
	0.4	-	+39.4	-	+32.8	
	1.0	-	+42.6	-	+33.2	
	2.0	+40.0	+44.8	-	+33.9	
	3.0	-	+47.1	-	+34.3	
	4.0	-	+47.9	-	+35.0	
Device Operating Voltage		+4.8	+5.0	+5.2	+3.0	V
Device Operating Current		-	97	120	60	mA
DC Current Variation vs. Temperature		-	-178	-	-54	μA/°C
DC Current Variation vs. Voltage		-	0.014	-	0.018	mA/mV
Thermal Resistance, Junction-to-Ground Lead		-	61	-	61	°C/W

1. Measured on Mini-Circuits Characterization test board TB-829-103+. See Characterization Test Circuit (Fig. 1).  
 2. Current increases at P1dB.





ULTRA-LINEAR LOW NOISE

# Monolithic Amplifier

## CMA-103+

50Ω 0.05 to 4 GHz

### ABSOLUTE MAXIMUM RATINGS

Parameter	Ratings
Operating Temperature (Ground Lead)	-40°C to +125°C
Storage Temperature	-65°C to +150°C
Operating Current at +5 V	200 mA
Power Dissipation at +5 V	1 W
Input Power (CW)	+21 dBm (50 to 2000 MHz) +26 dBm (2000 to 4000 MHz)
DC Voltage on Pin 6	+6 V

Permanent damage may occur if any of these limits are exceeded. These ratings are not intended for continuous normal operation.

### SIMPLIFIED SCHEMATIC AND PAD DESCRIPTION

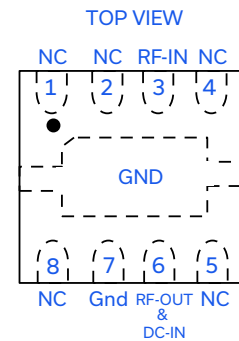
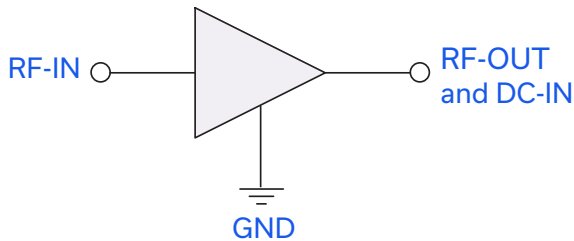

Function	Pin Number	Description
RF-IN	3	RF input pin. This pin requires the use of an external DC blocking capacitor chosen for the frequency of operation.
RF-OUT and DC-IN	6	RF output and bias pin. DC voltage is present on this pin; therefore a DC blocking capacitor is necessary for proper operation. An RF choke is needed to feed DC bias without loss of RF signal due to the bias connection, as shown in "Recommended Application Circuit", Fig. 2.
GND	7, Paddle	Connections to ground. Use via holes as shown in "Suggested Layout for PCB Design" to reduce ground path inductance for best performance.
NC	1,2,4,5,8	Not used internally. Connected to ground on test board.



ULTRA-LINEAR LOW NOISE

# Monolithic Amplifier

## CMA-103+

50Ω 0.05 to 4 GHz

### CHARACTERIZATION TEST CIRCUIT

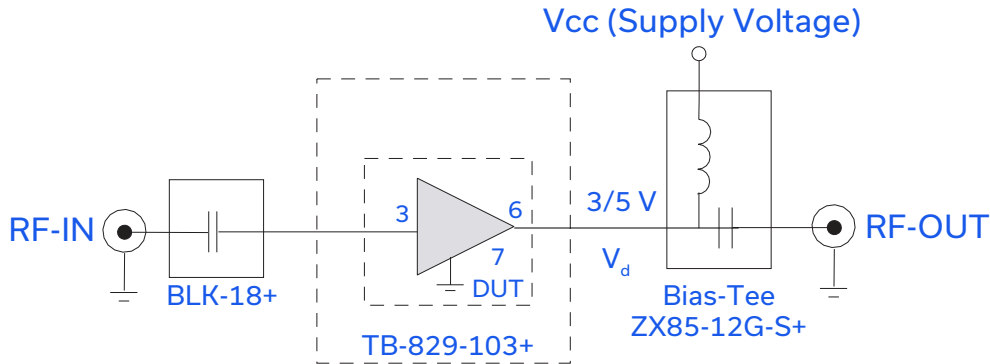
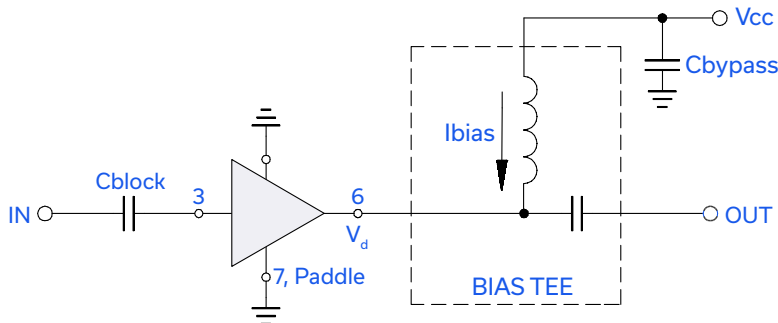

Fig 1. Block Diagram of Test Circuit used for characterization. (DUT tested on Mini-Circuits Characterization test board TB-829-103+) Gain, Return Loss, Output Power at 1 dB Compression (P1dB), Output IP3 (OIP3) and Noise Figure measured using Agilent's N5242A PNA-X microwave network analyzer.

Conditions:

1. Gain and Return Loss:  $P_{in} = -25$  dBm
2. Output IP3 (OIP3): Two tones, spaced 1 MHz apart, +5 dBm/tone at output

### RECOMMENDED APPLICATION CIRCUIT



$C_{block} = 0.001 \mu F$ , Bias-Tee=TCBT-14+,  $C_{bypass} = 0.1 \mu F$

Fig 2. Evaluation board TB-988-103+ includes case, connectors and components soldered to PCB

### PRODUCT MARKING

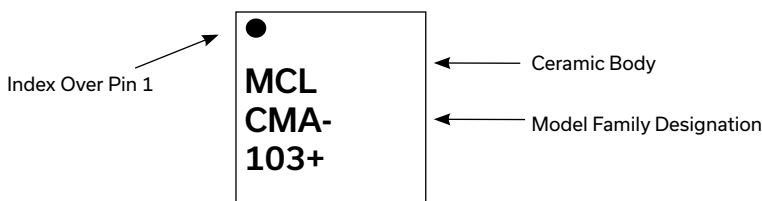

Markings in addition to model number designation may appear for internal quality control purposes.





ULTRA-LINEAR LOW NOISE

# Monolithic Amplifier

## CMA-103+

50Ω 0.05 to 4 GHz

ADDITIONAL DETAILED TECHNICAL INFORMATION IS AVAILABLE ON OUR DASHBOARD. [CLICK HERE](#)

Performance Data & Graphs	Table Graphs S-Parameter (S2P Files) Data Set (.zip file)
Case Style	DL1721 Ceramic package, exposed paddle, Terminal Finish: Ni,Pd,Au
Tape & Reel Standard Quantities Available on Reel	F66-1 7" Reels with 20, 50, 100, 200, 500, 1000 & 2000 devices
Suggested Layout for PCB Design	PL-602
Evaluation Board	TB-988-103+
Environmental Ratings	ENV68

### ESD RATING

Human Body Model (HBM): Class 1A (250 V to < 500 V) in accordance with ANSI/ESD STM 5.1 - 2001  
Machine Model (MM): Class M1 (25 V) in accordance with ANSI/ESD STM5.2-1999

### MSL RATING

Moisture Sensitivity: MSL1 (these parts are hermetic, air cavity and therefore, MSL ratings do not strictly apply. For handling purpose, use MSL1)

### QUALIFICATION TESTING

The table below shows the initial qualification testing performed. If required, parts can be subjected to 100% screening and qualifications testing per MIL standard requirement.

	Test Description	Test Method/Process	Results
1	Hermeticity (fine and gross leak)	MIL-STD-202 Method 112, Cond. C & D	Pass
2	Acceleration, 30Kg, Y1 Direction	MIL-STD-883 Method 2001 Cond. E	Pass
3	Vibration , 10-2000Hz sine, 20g, 3 axis	MIL-STD-202 Method 204, Cond. D	Pass
4	Mechanical shock	MIL-STD-202 Method 213, Cond . A	Pass
5	PIND 20G's @130 Hz	MIL-STD-750 Method 2052.2	Pass
6	Temp Cycle -55C/+125C, 1000 Cycles	MIL-STD-202 Method 107	Pass
7	Autoclave, 121C, RH 100%, 15 Psig, 96 hrs	JESD22-A102C	Pass
8	HTOL, 1000hrs, 105C at rated Voltage condition	MIL-STD-202 Method 108, Cond . D	Pass
9	Bend Test	JESD22-B113	Pass
10	Resistance to soldering heat, 3x reflow, 260C peak	JESD22-B102	Pass
11	Drop Test	JESD22-B111	Pass
12	Adhesion Strength	Push Test>10 lb	Pass

#### NOTES

- A. Performance and quality attributes and conditions not expressly stated in this specification document are intended to be excluded and do not form a part of this specification document.
- B. Electrical specifications and performance data contained in this specification document are based on Mini-Circuits' applicable established test performance criteria and measurement instructions.
- C. The parts covered by this specification document are subject to Mini-Circuits' standard limited warranty and terms and conditions (collectively, "Standard Terms"); Purchasers of this part are entitled to the rights and benefits contained therein. For a full statement of the standard terms and the exclusive rights and remedies thereunder, please visit Mini-Circuits' website at [www.minicircuits.com/terms/viewterm.html](http://www.minicircuits.com/terms/viewterm.html)



## Typical Performance Data

**NOTE: Use PDF Bookmarks to view DATA at required conditions**

**Definitions:**

Input Return Loss = -S11 (dB)

Gain(Power Gain) = S21 (dB)

Reverse Isolation = -S12 (dB)

Output Return Loss = -S22 (dB)

TEST CONDITIONS: Vd = 5.00V, Id = 95.61mA @ Temperature = +25°C

FREQ	Gain	Isolation	Input Return Loss	Output Return Loss	Stability		IP-3 Output	1dB Comp. Output	Noise Figure
					K	Measure			
(MHz)	(dB)	(dB)	(dB)	(dB)	K	Measure	(dBm)	(dBm)	(dB)
50	26.34	30.18	6.28	13.17	0.89	0.76	36.79	19.93	0.38
100	25.63	29.58	7.75	16.96	0.97	0.73	38.21	20.59	0.38
500	20.94	25.48	11.71	19.62	1.07	0.71	39.95	22.28	0.41
600	19.86	24.49	12.35	19.20	1.08	0.71	40.46	22.44	0.42
700	18.87	23.56	12.85	18.76	1.09	0.71	41.28	22.49	0.42
800	17.96	22.70	13.28	18.45	1.09	0.71	41.32	22.29	0.48
900	17.12	21.89	13.64	18.23	1.09	0.71	41.06	22.62	0.48
1000	16.35	21.15	13.96	17.97	1.10	0.71	42.40	22.78	0.53
1100	15.63	20.46	14.28	17.69	1.10	0.71	42.12	22.74	0.54
1200	14.97	19.82	14.51	17.48	1.10	0.71	42.27	22.64	0.55
1300	14.35	19.22	14.72	17.29	1.10	0.71	42.73	22.57	0.51
1400	13.78	18.65	14.90	17.10	1.10	0.71	42.96	22.92	0.66
1500	13.24	18.12	15.12	16.98	1.10	0.71	42.48	23.03	0.59
1600	12.74	17.62	15.33	16.83	1.10	0.70	44.65	22.64	0.63
1700	12.27	17.15	15.58	16.60	1.10	0.70	43.62	22.63	0.61
1800	11.82	16.70	15.78	16.36	1.10	0.70	43.52	23.14	0.66
1900	11.40	16.28	15.95	16.19	1.10	0.70	44.14	23.23	0.72
2000	11.00	15.87	16.13	16.06	1.10	0.70	43.16	23.17	0.70
2100	10.62	15.48	16.34	15.92	1.10	0.69	44.96	23.21	0.69
2200	10.26	15.11	16.51	15.85	1.10	0.69	44.41	23.21	0.80
2300	9.92	14.76	16.68	15.71	1.10	0.69	44.04	23.46	0.84
2400	9.59	14.42	16.90	15.52	1.10	0.69	45.88	23.15	0.78
2500	9.27	14.10	17.10	15.39	1.10	0.69	44.73	23.38	0.85
2600	8.98	13.78	17.28	15.30	1.09	0.68	44.78	23.53	0.89
2700	8.69	13.48	17.49	15.18	1.09	0.68	44.95	23.43	0.89
2800	8.42	13.19	17.71	15.03	1.09	0.68	45.70	23.34	1.01
2900	8.16	12.91	17.86	14.92	1.09	0.67	45.42	23.68	1.04
3000	7.90	12.64	18.15	14.76	1.09	0.67	43.50	23.74	1.01
3100	7.66	12.38	18.37	14.59	1.09	0.67	44.75	23.72	0.96
3200	7.43	12.13	18.52	14.56	1.09	0.66	46.22	23.66	1.12
3300	7.20	11.88	18.78	14.51	1.09	0.66	46.11	23.55	1.16
3400	6.99	11.65	18.97	14.43	1.09	0.66	48.03	24.01	1.24
3500	6.78	11.41	19.12	14.35	1.08	0.65	46.99	23.84	1.16
3600	6.58	11.19	19.31	14.34	1.08	0.65	46.27	24.11	1.10
3700	6.39	10.97	19.51	14.23	1.08	0.65	46.94	23.91	1.28
3800	6.20	10.76	19.66	14.16	1.08	0.65	47.60	24.25	1.31
3900	6.03	10.55	19.74	14.13	1.08	0.64	47.71	24.26	1.32
4000	5.85	10.36	19.91	14.07	1.08	0.64	50.71	24.23	1.51

## Typical Performance Data

### Definitions:

Input Return Loss = -S11 (dB)

Gain(Power Gain) = S21 (dB)

Reverse Isolation = -S12 (dB)

Output Return Loss = -S22 (dB)

TEST CONDITIONS: Vd = 5.00V, Id = 101.32mA @ Temperature = -45°C

FREQ	Gain	Isolation	Input Return Loss	Output Return Loss	Stability		IP-3 Output	1dB Comp. Output	Noise Figure
					K	Measure			
(MHz)	(dB)	(dB)	(dB)	(dB)	K	Measure	(dBm)	(dBm)	(dB)
50	26.40	29.87	6.79	13.64	0.87	0.75	40.13	19.67	0.34
100	25.55	29.15	8.86	19.25	0.97	0.69	42.25	20.30	0.28
500	20.97	25.31	13.18	23.19	1.09	0.67	42.24	22.96	0.30
600	19.93	24.34	13.74	21.80	1.09	0.67	42.56	22.91	0.30
700	18.96	23.43	14.14	21.21	1.10	0.67	42.98	23.02	0.31
800	18.07	22.59	14.56	20.36	1.10	0.68	42.74	22.89	0.33
900	17.25	21.80	14.75	19.75	1.10	0.68	42.90	23.41	0.34
1000	16.50	21.06	15.05	19.80	1.10	0.68	43.71	23.32	0.37
1100	15.80	20.38	15.55	18.86	1.10	0.68	43.69	23.32	0.43
1200	15.15	19.74	15.63	18.53	1.10	0.68	42.29	23.20	0.43
1300	14.55	19.13	15.79	18.74	1.10	0.68	42.93	23.18	0.45
1400	13.98	18.57	16.07	18.18	1.10	0.68	42.84	23.47	0.48
1500	13.45	18.04	16.12	18.08	1.10	0.68	42.74	23.57	0.43
1600	12.96	17.54	16.32	18.08	1.10	0.67	42.44	23.09	0.49
1700	12.48	17.07	16.60	17.64	1.10	0.67	43.68	23.30	0.49
1800	12.04	16.62	16.72	17.44	1.09	0.67	42.72	23.78	0.56
1900	11.63	16.19	16.93	17.26	1.09	0.67	43.24	23.82	0.54
2000	11.23	15.78	17.09	17.16	1.09	0.67	42.61	23.85	0.57
2100	10.86	15.39	17.29	17.06	1.09	0.67	42.82	23.92	0.60
2200	10.50	15.03	17.53	16.79	1.09	0.66	42.26	23.68	0.57
2300	10.16	14.67	17.66	16.78	1.09	0.66	43.81	24.18	0.65
2400	9.84	14.33	17.92	16.57	1.09	0.66	43.22	23.81	0.60
2500	9.52	14.01	18.26	16.11	1.09	0.65	42.45	24.09	0.65
2600	9.23	13.69	18.35	16.19	1.09	0.65	44.03	24.28	0.65
2700	8.95	13.39	18.55	16.16	1.08	0.65	43.19	24.06	0.72
2800	8.67	13.10	18.94	15.69	1.08	0.65	43.21	24.14	0.74
2900	8.41	12.82	18.96	15.75	1.08	0.64	44.36	24.63	0.84
3000	8.16	12.55	19.22	15.63	1.08	0.64	43.15	24.42	0.83
3100	7.91	12.29	19.42	15.26	1.08	0.64	43.52	24.37	0.72
3200	7.69	12.03	19.28	15.52	1.08	0.64	46.07	24.82	0.80
3300	7.46	11.79	19.58	15.42	1.08	0.63	43.67	24.21	0.83
3400	7.24	11.56	19.82	15.00	1.07	0.63	44.45	24.65	0.85
3500	7.04	11.32	19.73	15.21	1.07	0.63	45.91	24.71	0.84
3600	6.84	11.10	20.07	15.14	1.07	0.62	43.20	24.74	1.01
3700	6.64	10.89	20.46	14.66	1.07	0.62	44.99	24.75	0.95
3800	6.46	10.66	20.46	14.84	1.07	0.62	44.99	25.10	1.01
3900	6.28	10.46	20.76	14.77	1.07	0.61	44.54	25.03	0.94
4000	6.11	10.27	21.07	14.46	1.07	0.61	45.10	25.07	1.05

## Typical Performance Data

### Definitions:

Input Return Loss = -S11 (dB)

Gain(Power Gain) = S21 (dB)

Reverse Isolation = -S12 (dB)

Output Return Loss = -S22 (dB)

TEST CONDITIONS: Vd = 5.00V, Id = 80.58mA @ Temperature = +125°C

FREQ	Gain	Isolation	Input Return Loss	Output Return Loss	Stability		IP-3 Output	1dB Comp. Output	Noise Figure
					K	Measure			
(MHz)	(dB)	(dB)	(dB)	(dB)	K	Measure	(dBm)	(dBm)	(dB)
50	25.75	30.67	5.11	10.73	0.91	0.79	34.12	19.02	0.57
100	25.21	29.91	6.08	12.46	0.96	0.77	34.50	19.48	0.57
500	20.64	25.47	9.72	15.31	1.03	0.76	36.28	19.84	0.60
600	19.56	24.50	10.48	15.36	1.05	0.76	36.91	20.53	0.57
700	18.55	23.60	11.02	15.14	1.06	0.76	37.42	20.27	0.63
800	17.65	22.75	11.47	15.54	1.07	0.76	37.72	20.00	0.72
900	16.80	21.97	12.10	15.51	1.08	0.76	37.71	20.04	0.68
1000	16.01	21.26	12.52	14.95	1.08	0.75	38.04	20.69	0.77
1100	15.31	20.57	12.68	15.32	1.09	0.75	38.09	20.47	0.80
1200	14.64	19.94	13.10	15.40	1.09	0.75	39.05	20.43	0.79
1300	14.01	19.37	13.44	14.72	1.10	0.75	39.36	20.22	0.81
1400	13.44	18.81	13.40	14.94	1.10	0.75	39.31	20.82	0.93
1500	12.90	18.28	13.67	15.16	1.10	0.75	39.40	20.89	0.90
1600	12.38	17.81	14.05	14.48	1.10	0.75	40.03	20.71	0.90
1700	11.90	17.34	14.04	14.52	1.10	0.75	39.87	20.21	0.98
1800	11.46	16.88	14.23	14.76	1.11	0.75	40.14	20.88	1.01
1900	11.03	16.48	14.65	14.22	1.11	0.74	40.17	20.99	0.96
2000	10.62	16.07	14.75	13.98	1.11	0.74	40.41	20.70	1.07
2100	10.25	15.68	14.87	14.22	1.11	0.74	40.76	20.70	1.05
2200	9.88	15.32	15.23	13.98	1.11	0.74	40.98	21.20	1.12
2300	9.54	14.97	15.37	13.69	1.11	0.73	40.50	21.07	1.12
2400	9.22	14.63	15.45	13.80	1.11	0.73	41.19	20.82	1.20
2500	8.90	14.31	15.74	13.78	1.11	0.73	41.93	20.96	1.20
2600	8.59	14.00	15.95	13.43	1.11	0.72	41.11	21.17	1.24
2700	8.31	13.69	16.01	13.52	1.11	0.72	41.49	21.18	1.31
2800	8.04	13.40	16.25	13.67	1.11	0.72	41.65	20.90	1.38
2900	7.78	13.13	16.51	13.34	1.10	0.71	40.66	21.03	1.39
3000	7.52	12.86	16.69	13.25	1.10	0.71	41.14	21.58	1.36
3100	7.29	12.58	16.91	13.50	1.11	0.71	41.00	21.42	1.36
3200	7.05	12.34	17.27	13.21	1.10	0.70	41.20	20.86	1.42
3300	6.83	12.09	17.53	13.05	1.10	0.70	42.09	21.45	1.61
3400	6.62	11.84	17.70	13.39	1.10	0.70	41.98	21.98	1.49
3500	6.41	11.61	18.00	13.22	1.10	0.69	41.53	21.40	1.44
3600	6.21	11.39	18.21	13.02	1.10	0.69	42.33	21.83	1.53
3700	6.02	11.17	18.34	13.32	1.10	0.69	41.91	21.64	1.58
3800	5.83	10.96	18.57	13.24	1.10	0.69	41.32	21.85	1.82
3900	5.65	10.75	18.56	13.07	1.10	0.68	42.56	21.97	1.91
4000	5.48	10.56	18.60	13.33	1.10	0.68	42.39	21.90	1.98

## Typical Performance Curves

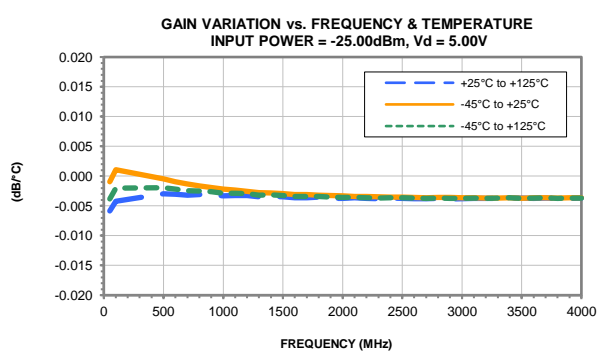
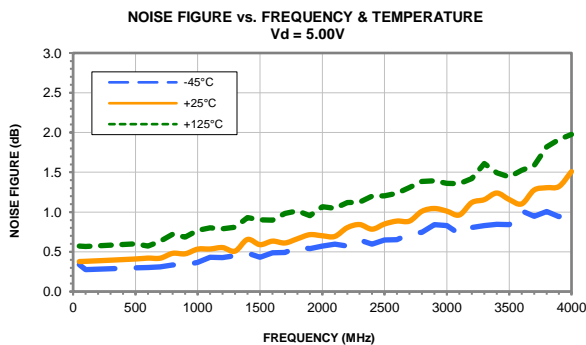
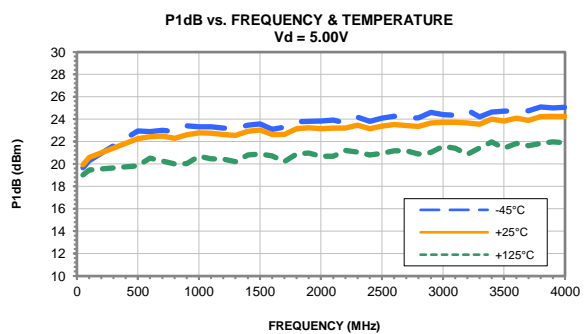
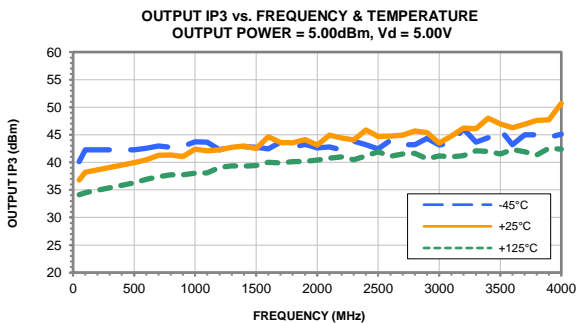
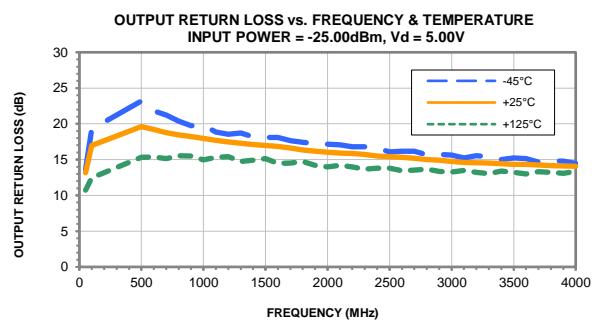
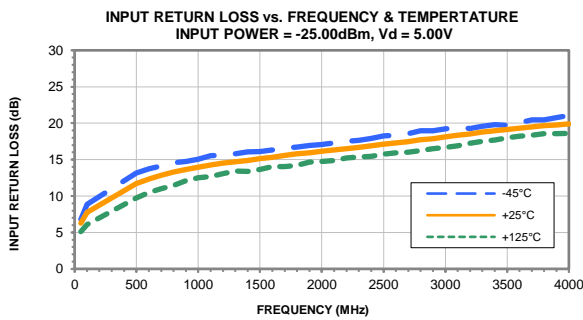
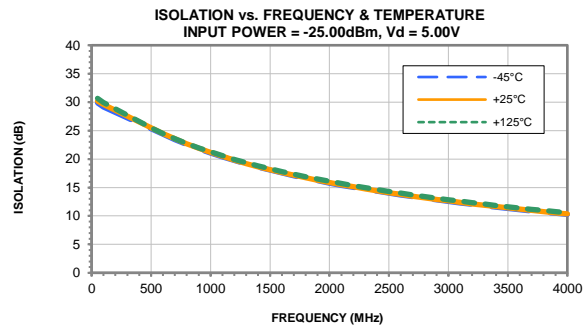
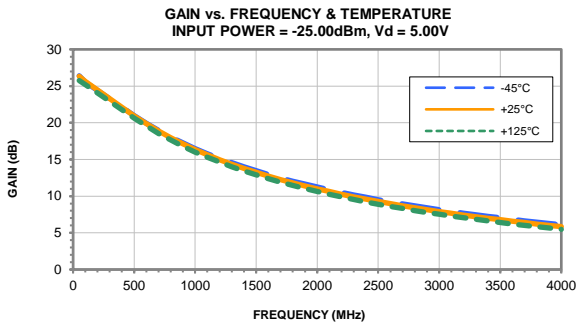

### Outline Dimensions

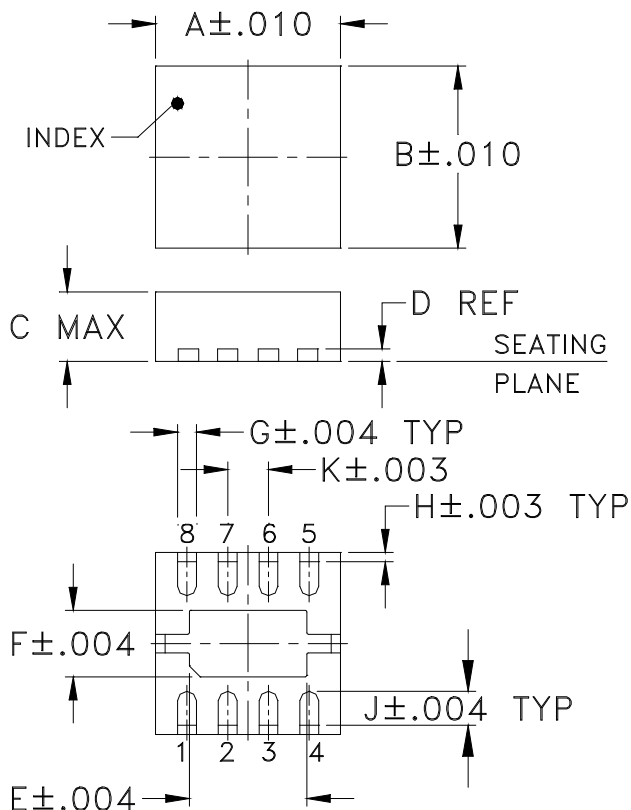

### PCB Land Pattern

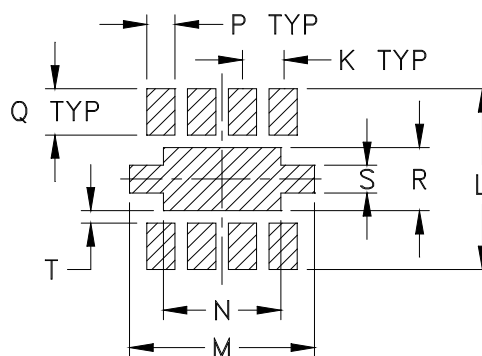

Suggested Layout,  
Tolerance to be within  $\pm .002$

CASE #	A	B	C	D	E	F	G	H	J	K	L	M	N
DL1721	.118 (3.00)	.118 (3.00)	.045 (1.14)	.008 (0.20)	.075 (1.91)	.043 (1.09)	.012 (0.30)	.006 (0.15)	.022 (0.56)	.026 (0.66)	.117 (2.97)	.118 (3.00)	.075 (1.91)

CASE #	P	Q	R	S	T	WT. GRAM
DL1721	.018 (0.46)	.030 (0.76)	.041 (1.04)	.018 (0.46)	.008 (0.20)	.02

Dimensions are in inches (mm). Tolerances: 3Pl.  $\pm .004$ , unless otherwise specified.

#### Notes:

1. Case material: LTCC.
2. Termination finish: Nickel-Palladium-Gold plating.



P.O. Box 350166, Brooklyn, New York 11235-0003 (718) 934-4500 Fax (718) 332-4661 For detailed performance specs & shopping online see Mini-Circuits web site



The Design Engineers Search Engine Provides ACTUAL Data Instantly From MINI-CIRCUITS At: [www.minicircuits.com](http://www.minicircuits.com)

RF/IF MICROWAVE COMPONENTS

# Tape & Reel Packaging TR-F66-1

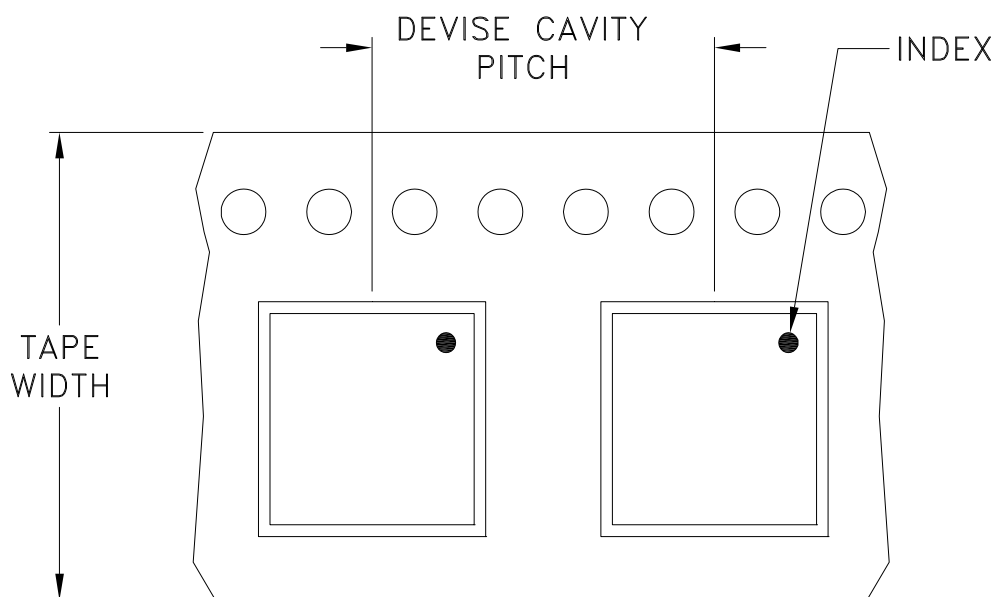

Tape Width, mm	Device Cavity Pitch, mm	Reel Size, inches	Devices per Reel see note	
8	4	7	Small quantity standard	20
				50
				100
				200
				500
		7	Standard	1000, 2000

Note: Please consult individual model data sheet to determine device per reel availability.

Mini-Circuits carrier tape materials provide protection from ESD (Electro-Static Discharge) during handling and transportation. Tapes are static dissipative and comply with industry standards EIA-481/EIA-541.

Go to: [www.minicircuits.com/pages/pdfs/tape.pdf](http://www.minicircuits.com/pages/pdfs/tape.pdf)



INTERNET <http://www.minicircuits.com>

P.O. Box 350166, Brooklyn, New York 11235-0003 (718) 934-4500 Fax (718) 332-4661

Distribution Centers NORTH AMERICA 800-654-7949 • 417-335-5935 • Fax 417-335-5945 • EUROPE 44-1252-832600 • Fax 44-1252-837010

Mini-Circuits ISO 9001 & ISO 14001 Certified

THIRD ANGLE PROJECTION

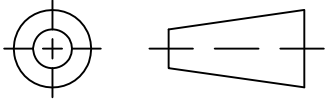

REVISIONS

REV	ECN No.	DESCRIPTION	DATE	DR	AUTH
OR	M169228	NEW RELEASE	08/08/18	ITG	DL

SUGGESTED MOUNTING CONFIGURATION  
FOR DL1721 CASE STYLE, "08AM19" PIN CODE

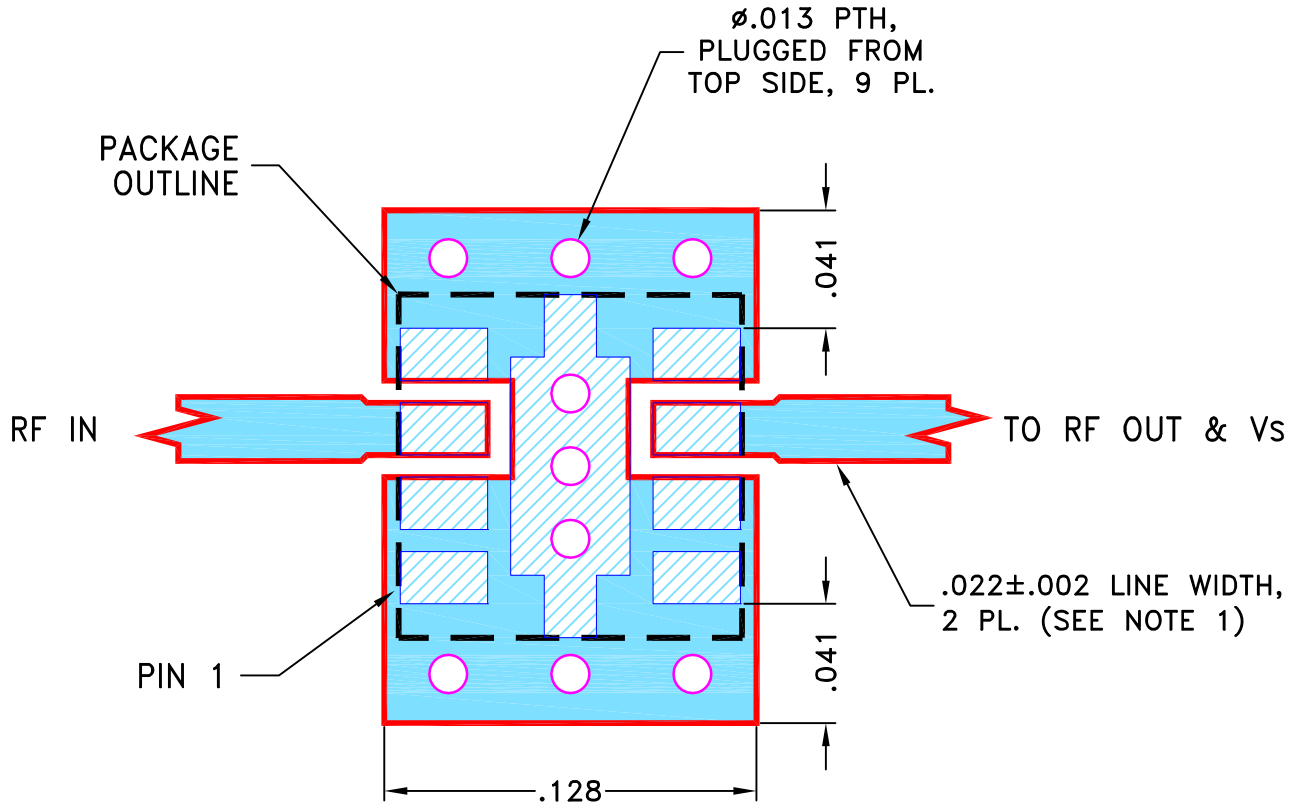

**NOTES:**

1. TRACE WIDTH IS SHOWN FOR ROGERS RO4350B WITH DIELECTRIC THICKNESS  $.010 \pm .001$ . COPPER: 1/2 OZ. EACH SIDE. FOR OTHER MATERIALS TRACE WIDTH MAY NEED TO BE MODIFIED.
2. BOTTOM SIDE OF THE PCB IS CONTINUOUS GROUND PLANE.

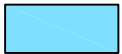

DENOTES PCB COPPER LAYOUT WITH SMOBC (SOLDER MASK OVER BARE COPPER).

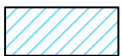

DENOTES COPPER LAND PATTERN FREE OF SOLDER MASK.

UNLESS OTHERWISE SPECIFIED	INITIALS	DATE
DIMENSIONS ARE IN INCHES TOLERANCES ON: 2 PL DECIMALS ± 3 PL DECIMALS ± .005 ANGLES ± FRACTIONS ±	DRAWN	ITG 07/26/18
	CHECKED	GF 08/01/18
	APPROVED	DL 08/08/18



**Mini-Circuits®**

13 Neptune Avenue  
Brooklyn NY 11235

PL, 08AM19, DL1721, TB-988-103+

SIZE A	CODE IDENT 15542	DRAWING NO: 98-PL-602	REV: OR
FILE: 98PL602	SCALE: 15:1	SHEET: 1 OF 1	

THIS DOCUMENT AND ITS CONTENTS ARE THE PROPERTY OF MINI-CIRCUITS. EXCEPT FOR USE EXPRESSLY GRANTED, IN WRITING, TO ITS VENDORS, VENDEE AND THE UNITED STATES GOVERNMENT, MINI-CIRCUITS RESERVES ALL PROPRIETARY DESIGN, USE, MANUFACTURING AND REPRODUCTION RIGHTS THERETO. THESE CONTENTS SHALL NOT BE USED, DUPLICATED OR DISCLOSED TO ANY OUTSIDE PARTY, IN WHOLE OR IN PART, WITHOUT WRITTEN PERMISSION OF MINI-CIRCUITS.

# Evaluation Board and Circuit

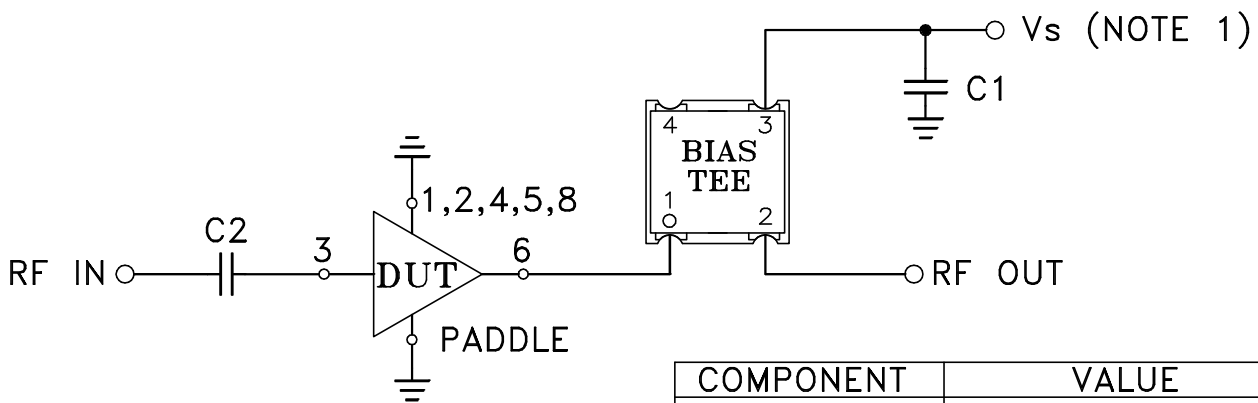
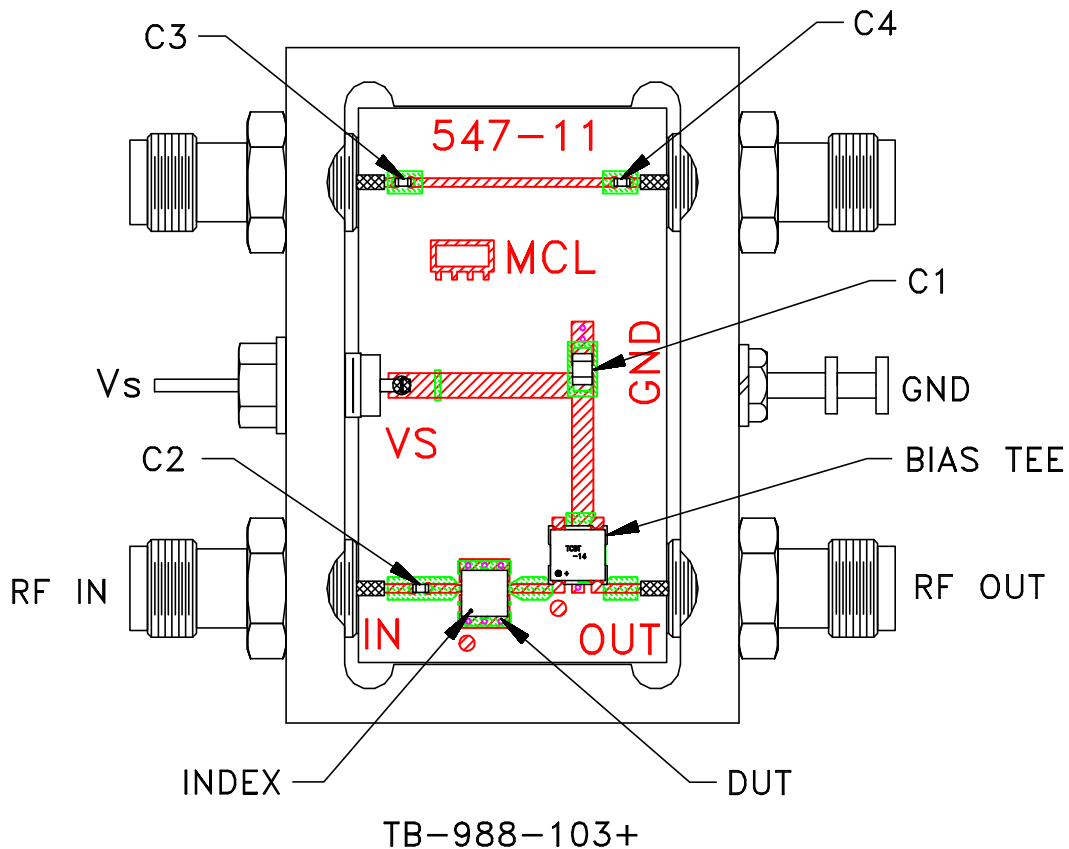

COMPONENT	VALUE
DUT	CMA-103+
C1 (bypass)	0.1 $\mu$ F(SIZE 0805)
C2-C4 (Note 4)	0.001 $\mu$ F(SIZE 0402)
BIAS TEE	Mini-Circuits TCBT-14+

Schematic Diagram

## NOTES:

1. Vcc voltage:  $+5 \pm 0.2V / 3 \pm 0.2V$ .
2. SMA Female connectors.
3. PCB material: Rogers R04350 or equivalent, dielectric constant=3.5, dielectric thickness=.010 inch.
4. Capacitor C2-C4 should be free of resonance up to the highest frequency specified.

 **Mini-Circuits®**



All Mini-Circuits products are manufactured under exacting quality assurance and control standards, and are capable of meeting published specifications after being subjected to any or all of the following physical and environmental test.

Specification	Test/Inspection Condition	Reference/Spec
Operating Temperature	-55° to 105°C	Individual Model Data Sheet
Storage Temperature	-65° to 125° C	Individual Model Data Sheet
Thermal Shock (device level)	-55° to 125°C, 100 cycles	MIL-STD-202, Method 107
Thermal Shock (board level)	-55° to 125°C, 1000 cycles	MIL-STD-202, Method 107
Constant Acceleration	Y1 plane only, 30 Kg	MIL-STD-883, Method 2001, Cond. E
Vibration	10-2000MHz sine, 20g, 3 axis	MIL-STD-202, Method 204, Cond. D
Mechanical Shock	Y1 plane, 5 pulses, .5ms, 1.5 Kg	MIL-STD-202, Method 213, Cond. A
PIND	20G's @130 Hz	MIL-STD-750, Method 2052.2
Resistance to Soldering Heat	3X Reflow, Peak Temperature 260°C, electrical End points	JESD22-B102
Resistance to Solvent	15 pieces, 5 pieces each solvent, marking permanency	MIL-STD-202, Method 215
Moisture Sensitivity Level	Hermetic device, MSL-1 by construction	JESD22-A113, MSL1/260
Hermeticity	Fine Leak, Gross Leak	MIL-STD-202, Method 112, Cond. C&D



All Mini-Circuits products are manufactured under exacting quality assurance and control standards, and are capable of meeting published specifications after being subjected to any or all of the following physical and environmental test.

Specification	Test/Inspection Condition	Reference/Spec
Autoclave	15 psig, 100% RH, 121°C, 96 hours	JEDEC-STD-22-B, Method A102