



COAXIAL

# Adapter

DINF-NF+

50Ω DC to 6 GHz DIN Female to N-Type Female

## KEY FEATURES

- Ultra-Wideband, DC to 6 GHz
- Low Insertion Loss, 0.06 dB Typ. to 6 GHz
- Excellent VSWR, 1.06:1 Typ. to 6 GHz
- Straight Body



Generic photo used for illustration purposes only

## PRODUCT OVERVIEW

Mini-Circuits' DINF-NF+ is a coaxial DIN female to N-type female adapter supporting a wide range of applications from DC to 6 GHz. This model provides excellent VSWR and low insertion loss over the frequency band. The DINF-NF+ features passivated stainless steel construction with a gold-plated beryllium copper center pin and measures only 1.378" in length.

## ELECTRICAL SPECIFICATIONS<sup>1</sup> AT +25 °C

Parameter	Frequency (GHz)	Min.	Typ.	Max.	Units
Frequency Range		DC		6	GHz
Insertion Loss	0.01-6	-	0.06	0.25	dB
VSWR	0.01-6	-	1.06	1.20	:1

1. Specifications are tested to minimum frequency of 0.01 GHz.

## ABSOLUTE MAXIMUM RATINGS<sup>2</sup>

Operating Case Temperature	-45 °C to +125 °C
Storage Temperature	-45 °C to +125 °C

2. Permanent damage may occur if any of these limits are exceeded.





COAXIAL

# Adapter

DINF-NF+

Mini-Circuits

50Ω DC to 6 GHz DIN Female to N-Type Female

## TYPICAL PERFORMANCE GRAPHS

INSERTION LOSS (+25 °C)

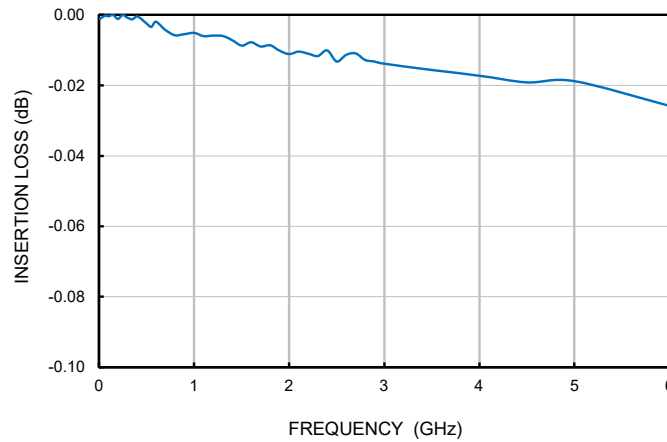

DIN FEMALE VSWR (+25 °C)

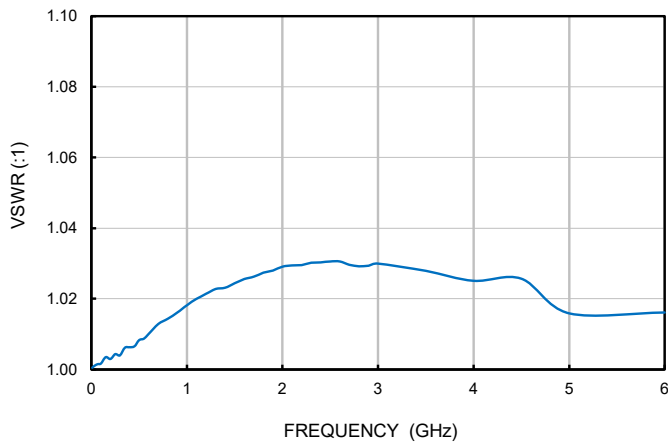

N FEMALE VSWR (+25 °C)

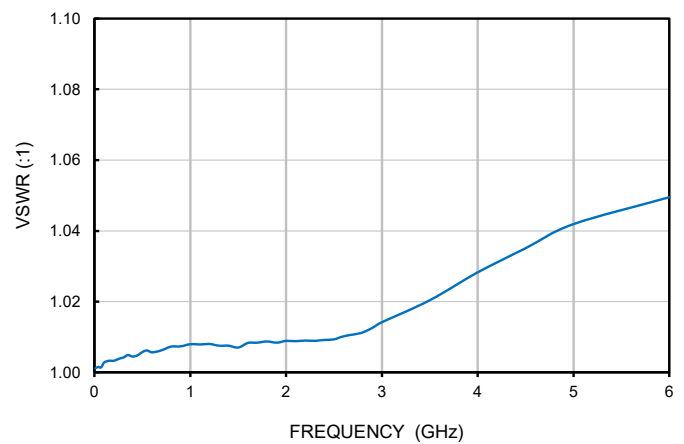

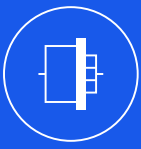

COAXIAL

# Adapter

DINF-NF+

Mini-Circuits

50Ω DC to 6 GHz DIN Female to N-Type Female

## CONNECTOR SPECIFICATIONS

Description	Connector 1	Connector 2
Connector Type	DIN Female	N-Type Female
Orientation	Straight	Straight

## CASE STYLE DRAWING

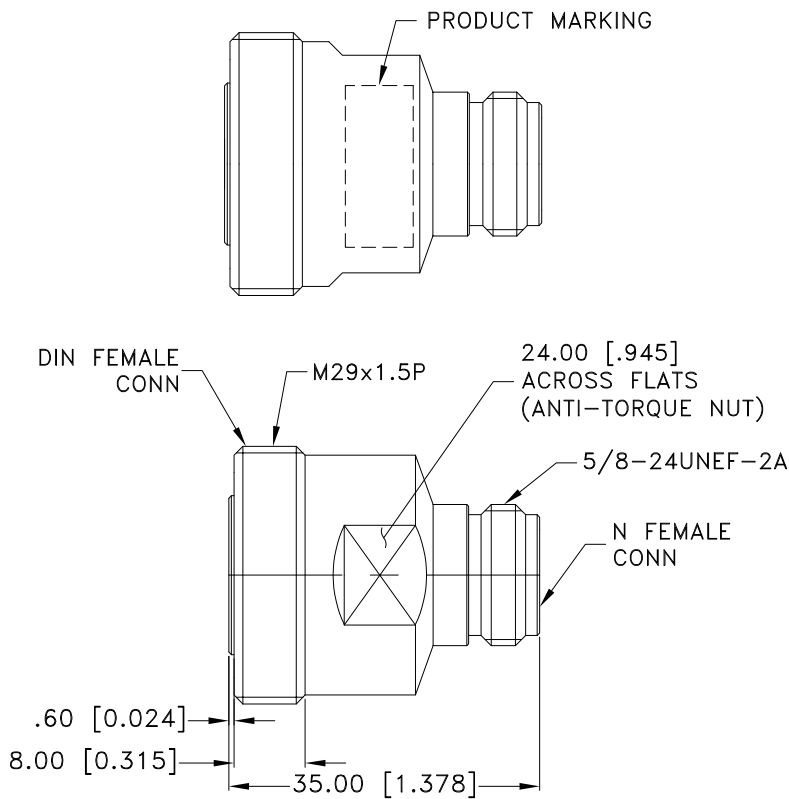

Dimensions are in mm [Inches]. Tolerances: 2 Pl.±0.40 mm

## PRODUCT MARKING\*: DINF-NF+

\*Marking may contain other features or characters for internal lot control.





COAXIAL

# Adapter

DINF-NF+

Mini-Circuits

50Ω DC to 6 GHz DIN Female to N-Type Female

ADDITIONAL INFORMATION IS AVAILABLE ON OUR DASHBOARD

[CLICK HERE](#)

Performance Data & Graphs	Data Graphs S-Parameter (S2P Files) Data Set (.zip file)
Case Style	DJ3843
RoHS Status	Compliant
Environmental Ratings	ENV152

**NOTES**

- A. Performance and quality attributes and conditions not expressly stated in this specification document are intended to be excluded and do not form a part of this specification document.
- B. Electrical specifications and performance data contained in this specification document are based on Mini-Circuits' applicable established test performance criteria and measurement instructions.
- C. The parts covered by this specification document are subject to Mini-Circuits' standard limited warranty and terms and conditions (collectively, "Standard Terms"); Purchasers of this part are entitled to the rights and benefits contained therein. For a full statement of the standard terms and the exclusive rights and remedies thereunder, please visit Mini-Circuits' website at [www.minicircuits.com/terms/viewterm.html](http://www.minicircuits.com/terms/viewterm.html)



# Adapter, DIN-Female to N-Female

# DINF-NF+

## Typical Performance Data

FREQ.	INSERTION LOSS	DIN-FEMALE VSWR	N-FEMALE VSWR
(GHz)	(dB)	(:1)	(:1)
0.01	0.00	1.00	1.00
0.04	0.00	1.00	1.00
0.07	0.00	1.00	1.00
0.10	0.00	1.00	1.00
0.15	0.00	1.00	1.00
0.20	0.00	1.00	1.00
0.25	0.00	1.00	1.00
0.30	0.00	1.00	1.00
0.35	0.00	1.01	1.01
0.40	0.00	1.01	1.00
0.45	0.00	1.01	1.00
0.50	0.00	1.01	1.01
0.55	0.00	1.01	1.01
0.60	0.00	1.01	1.01
0.70	0.00	1.01	1.01
0.80	0.01	1.01	1.01
0.90	0.01	1.02	1.01
1.00	0.00	1.02	1.01
1.10	0.01	1.02	1.01
1.20	0.01	1.02	1.01
1.30	0.01	1.02	1.01
1.40	0.01	1.02	1.01
1.50	0.01	1.02	1.01
1.60	0.01	1.03	1.01
1.70	0.01	1.03	1.01
1.80	0.01	1.03	1.01
1.90	0.01	1.03	1.01
2.00	0.01	1.03	1.01
2.10	0.01	1.03	1.01
2.20	0.01	1.03	1.01
2.30	0.01	1.03	1.01
2.40	0.01	1.03	1.01
2.50	0.01	1.03	1.01
2.60	0.01	1.03	1.01
2.70	0.01	1.03	1.01
2.80	0.02	1.03	1.01
2.90	0.02	1.03	1.01
3.00	0.02	1.03	1.02
3.50	0.02	1.03	1.02
4.00	0.02	1.03	1.03
4.50	0.03	1.03	1.04
5.00	0.03	1.02	1.04
6.00	0.04	1.02	1.05



P.O. Box 350166, Brooklyn, New York 11235-0003 • Fax (718) 934-4500 • Fax (718) 332-4661 For detailed performance specs & shopping online see Mini-Circuits web site  
 The Design Engineers Search Engine Provides ACTUAL Data Instantly From MINI-CIRCUITS At: [www.minicircuits.com](http://www.minicircuits.com)



IF/RF MICROWAVE COMPONENTS

## Typical Performance Curves

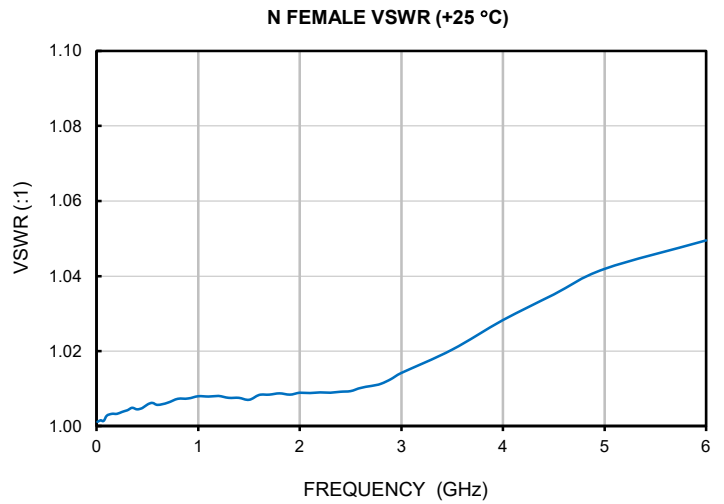
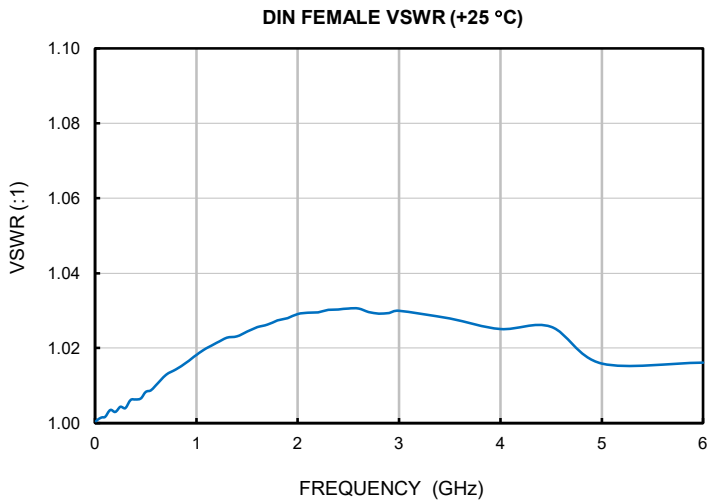
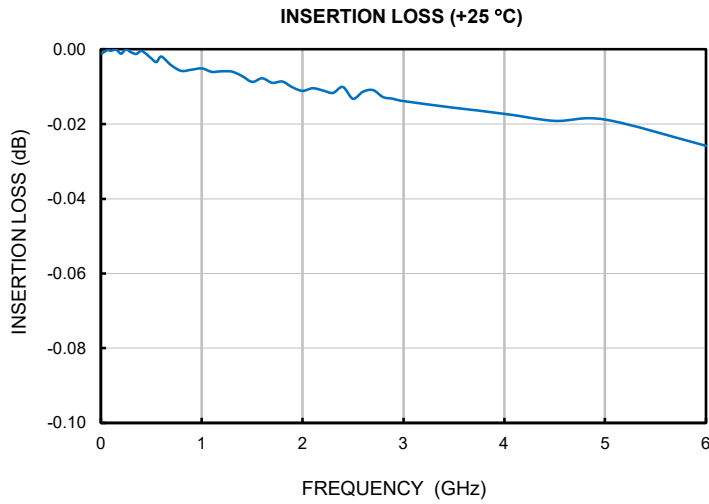

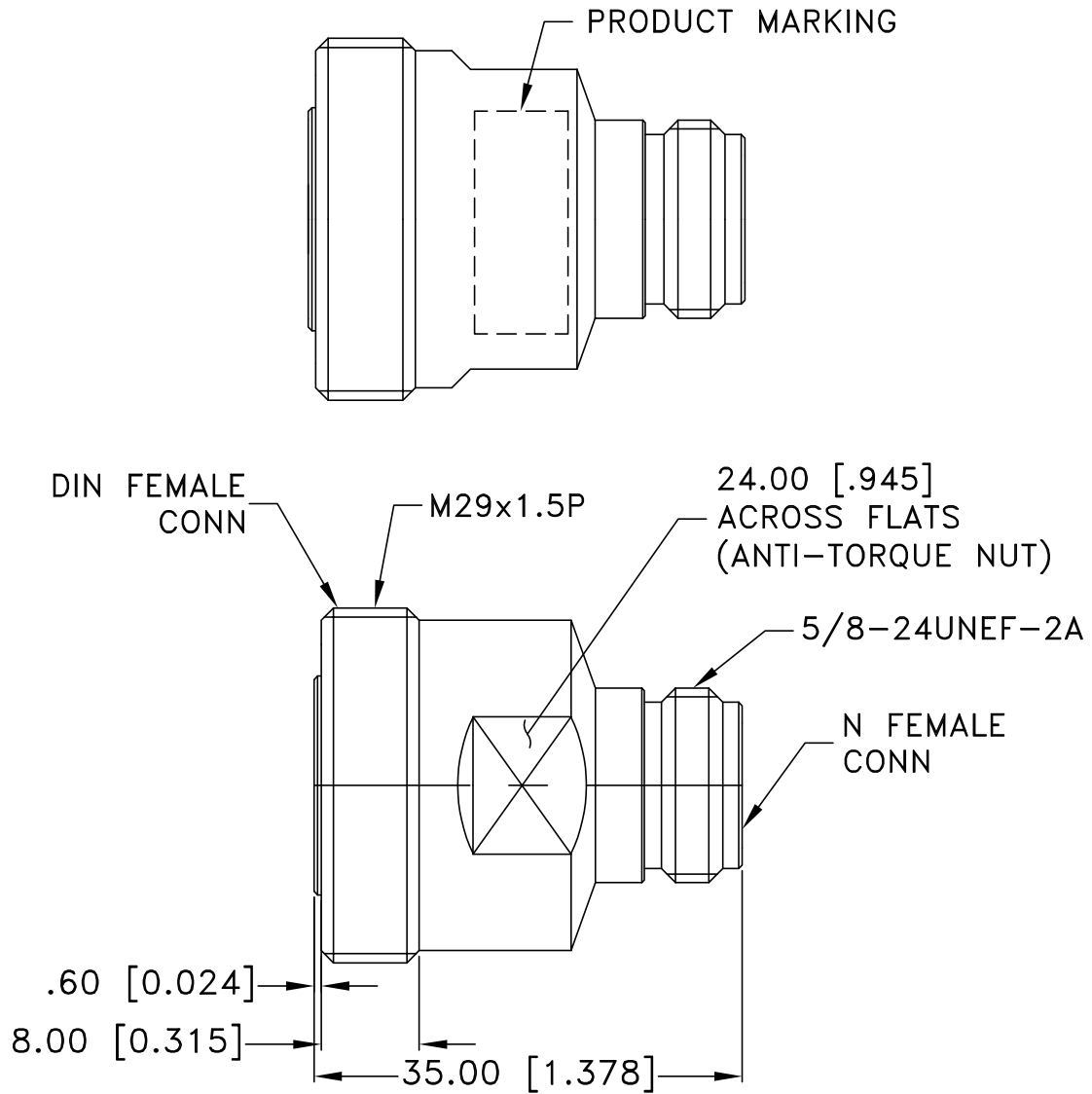

Dimensions are in mm [Inches]. Tolerances: 2 Pl.±0.40 mm

Notes:

Case material: Brass.  
Finish: Tri Metal Alloy Plating.



P.O. Box 350166, Brooklyn, New York 11235-0003 (718) 934-4500 Fax (718) 332-4661 For detailed performance specs & shopping online see Mini-Circuits web site



The Design Engineers Search Engine Provides ACTUAL Data Instantly From MINI-CIRCUITS At: [www.minicircuits.com](http://www.minicircuits.com)

RF/IF MICROWAVE COMPONENTS

All Mini-Circuits products are manufactured under exacting quality assurance and control standards, and are capable of meeting published specifications after being subjected to any or all of the following physical and environmental test.

<b>Specification</b>	<b>Test/Inspection Condition</b>	<b>Reference/Spec</b>
Operating Temperature	-45° to +125° C	Individual Model Data Sheet
Storage Temperature	-45° to +125° C	Individual Model Data Sheet
Thermal Shock	-55° to +125° C, 5cycles, 15 min dwell time	MIL-STD-202, Method 107, Condition B except -55° C instead of -65° C
Connector Durability	500 mating/unmating cycles	MIL-PRF-39012E, PARAGRAPH 4.6.12