

Ceramic

Dual Low Pass Filter

DLFCV-1750+

50Ω DC to 1750 MHz

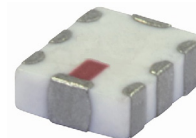

Generic photo used for illustration purposes only
CASE STYLE: JV1210C-6

The Big Deal

- Differential operation
- Fast roll off
- Small size
- Very wide stopband, up to 10000 MHz

Product Overview

Mini-Circuits' DLFCV-1750+ is an LTCC dual low pass filter with a passband from DC to 1750 MHz. This can also operate as balanced input / output filter. This model is ideal for applications requiring filtering of balanced signals on dual 50Ω lines such as DACs/ADCs, systems with very low noise requirements and more. The filter provides low insertion loss in the passband, fast roll off in the transition, and a very wide stopband up to 10000 MHz, making it suitable for use in wideband systems with many harmonics and spurious products. The unit comes housed in a tiny, rugged 1210 ceramic package, with wraparound terminations for excellent solderability.

Key Features

Feature	Advantages
Dual filter	Allows filtering of balanced signals in a single, tiny component. Eliminates the need for binning and matching of separate discrete components.
Tiny size (0.126" x 0.098" x 0.039")	Saves space in dense circuit board layouts and minimizes the effects of parasitics.
Fast roll off	Provides sharp rejection at frequencies close to the passband.
Ultra-wide stopband	Provides excellent rejection over a wide band, ideal for blocking harmonics in wide-band communications systems.
Wrap-around terminations	Provides excellent solderability and easy visual inspection.

Notes

- A. Performance and quality attributes and conditions not expressly stated in this specification document are intended to be excluded and do not form a part of this specification document.
B. Electrical specifications and performance data contained in this specification document are based on Mini-Circuit's applicable established test performance criteria and measurement instructions.
C. The parts covered by this specification document are subject to Mini-Circuits standard limited warranty and terms and conditions (collectively, "Standard Terms"); Purchasers of this part are entitled to the rights and benefits contained therein. For a full statement of the Standard Terms and the exclusive rights and remedies thereunder, please visit Mini-Circuits' website at www.minicircuits.com/MCLStore/terms.jsp



Dual Low Pass Filter

DLFCV-1750+

50Ω DC to 1750 MHz

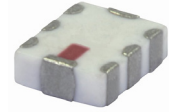

Generic photo used for illustration purposes only
CASE STYLE: JV1210C-6

Maximum Ratings

Operating Temperature	-55°C to 100°C
Storage Temperature	-55°C to 100°C
RF Power Input*	3 W Max. at 25°C

* Passband rating, derate linearly to 1.5W at 85°C ambient. Permanent damage may occur if any of these limits are exceeded.

Pin Connections

RF IN1, RF IN2	1, 3
RF OUT1, RF OUT2	7, 5
GROUND	2, 4, 6, 8

Product Marking: KT

Outline Drawing

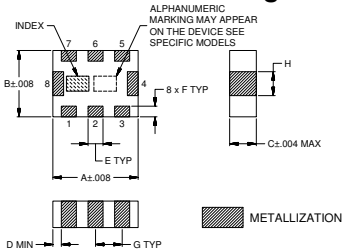

PCB LAND PATTERN

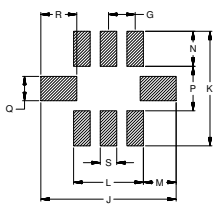

SUGGESTED LAYOUT
TOLERANCE TO BE WITHIN ±.002

Outline Dimensions (inch/mm)

A	B	C	D	E	F	G	H	J
.126	.098	.039	.004	.022	.016	.039	.035	.200
3.20	2.50	1.00	0.10	0.56	0.40	1.00	0.90	5.08
K	L	M	N	P	Q	R	S	Wt.
.170	.103	.048	.052	.066	.036	.053	.024	grams
4.32	2.62	1.23	1.32	1.68	0.92	1.35	0.62	0.03

Note: Please refer to case style drawing for details

Demo Board MCL P/N: TB-1074+ Suggested PCB Layout (PL-600)

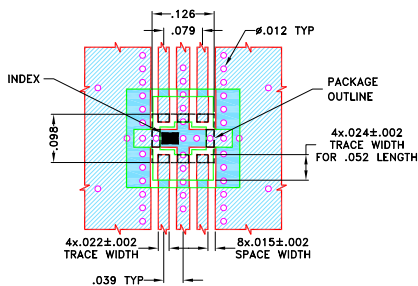

NOTES:

- TRACE WIDTH IS SHOWN FOR ROGERS (RO4350B) WITH DIELECTRIC THICKNESS .010"±.001". COPPER: 1/20z. EACH SIDE. FOR OTHER MATERIALS TRACE WIDTH MAY NEED TO BE MODIFIED.
 - BOTTOM SIDE OF THE PCB IS CONTINUOUS GROUND PLANE.
- DENOTES PCB COPPER LAYOUT WITH SMOBC (SOLDER MASK OVER BARE COPPER)
 DENOTES COPPER LAND PATTERN FREE OF SOLDERMASK

Notes

- Performance and quality attributes and conditions not expressly stated in this specification document are intended to be excluded and do not form a part of this specification document.
- Electrical specifications and performance data contained in this specification document are based on Mini-Circuit's applicable established test performance criteria and measurement instructions.
- The parts covered by this specification document are subject to Mini-Circuits standard limited warranty and terms and conditions (collectively, "Standard Terms"); Purchasers of this part are entitled to the rights and benefits contained therein. For a full statement of the Standard Terms and the exclusive rights and remedies thereunder, please visit Mini-Circuits' website at www.minicircuits.com/MCLStore/terms.jsp

Features

- Low insertion loss
- Small size
- Excellent return loss
- High rejection

Applications

- Military Radio communication
- VHF/UHF transmitters/receivers
- Harmonic rejection
- Output of the A/D convertor

Electrical Specifications^(1,2) at 25°C

Parameter	F#	Frequency (MHz)	Min.	Typ.	Max.	Unit	
Pass Band	Insertion Loss	DC-F1	DC-1750	—	1.5	2.5	dB
	Freq. Cut-Off	F2 *	1900	—	3.0	—	dB
	Amp Unbalance	DC-F1	DC-1750	—	0.2	—	dB
	Pha Unbalance	DC-F1	DC-1750	—	3.0	—	deg
	VSWR	DC-F1	DC-1750	—	1.5	—	:1
Stop Band	Insertion Loss	F3-F4	2500-5000	35	50	—	dB
		F4-F5	5000-7000	—	33	—	dB
		F5-F6	7000-10000	—	25	—	dB
	Isolation (between filters)	F3-F4	2500-5000	—	50	—	dB
	VSWR	F3-F4	2500-5000	—	20	—	:1

1 In Applications where DC voltage and/or current is present at either input or output ports, DC de-coupling capacitors are required. If DC pass from IN-OUT is required, please contact Mini-Circuits for alternatives.

2 Measured on Mini-Circuits Characterization Test Board TB-1074+

* Typically, a ±5% frequency deviation from the stated value may occur on a unit-to-unit basis.

Typical Frequency Response

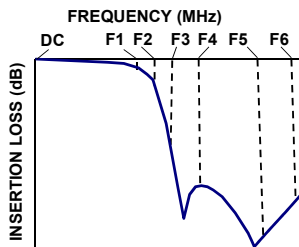

Functional Schematic

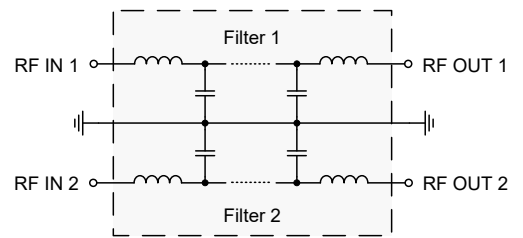

Typical Performance Data at 25°C

Freq. (MHz)	Insertion Loss		Isolation (between filters) (dB)	VSWR		Freq. (MHz)	Amp Unbal. (dB)	Phase Unbal. (deg)	Group Delay	
	Filter1 (dB)	Filter2 (dB)		Filter1 (:1)	Filter2 (:1)				Filter1 (ns)	Filter2 (ns)
10.0	0.11	0.11	87.77	1.02	1.02	10.0	0.003	0.04	0.26	0.28
100.0	0.15	0.16	79.19	1.03	1.04	40.0	0.001	0.00	0.30	0.30
500.0	0.29	0.29	63.93	1.14	1.15	60.0	0.004	0.04	0.30	0.30
1000.0	0.53	0.52	53.94	1.34	1.35	100.0	0.007	0.07	0.30	0.30
1500.0	0.95	0.95	46.85	1.45	1.49	140.0	0.005	0.13	0.30	0.30
1750.0	1.35	1.32	46.48	1.24	1.28	200.0	0.007	0.21	0.30	0.30
1900.0	2.23	2.19	48.56	1.22	1.31	260.0	0.004	0.26	0.30	0.30
1950.0	3.21	3.19	47.55	1.60	1.75	300.0	0.002	0.29	0.30	0.30
2100.0	14.17	13.63	46.63	5.16	5.26	350.0	0.002	0.34	0.30	0.30
2150.0	20.69	19.75	48.93	6.88	6.57	400.0	0.001	0.38	0.30	0.30
2210.0	30.19	28.78	52.62	9.01	8.04	450.0	0.000	0.41	0.31	0.30
2220.0	32.03	30.53	53.38	9.39	8.29	500.0	0.003	0.45	0.31	0.31
2400.0	47.89	46.03	73.63	17.08	14.03	600.0	0.004	0.53	0.32	0.32
2500.0	56.71	52.69	64.96	22.32	18.39	700.0	0.005	0.61	0.33	0.33
4900.0	51.14	55.02	52.53	61.70	66.16	800.0	0.005	0.70	0.34	0.34
5000.0	48.85	49.66	48.84	60.58	64.82	900.0	0.006	0.77	0.36	0.35
5500.0	46.75	48.01	47.55	60.89	62.75	1000.0	0.008	0.85	0.37	0.37
6000.0	43.54	44.63	45.08	58.62	62.63	1250.0	0.008	1.08	0.44	0.44
7000.0	37.35	37.19	41.36	55.74	50.45	1500.0	0.002	1.43	0.57	0.56
8000.0	31.66	30.88	34.28	46.88	45.70	1600.0	0.005	1.67	0.66	0.65
9000.0	28.34	29.22	36.95	150.58	109.47	1700.0	0.013	1.96	0.79	0.78
10000.0	29.69	31.02	40.62	95.46	116.97	1750.0	0.025	2.13	0.88	0.87

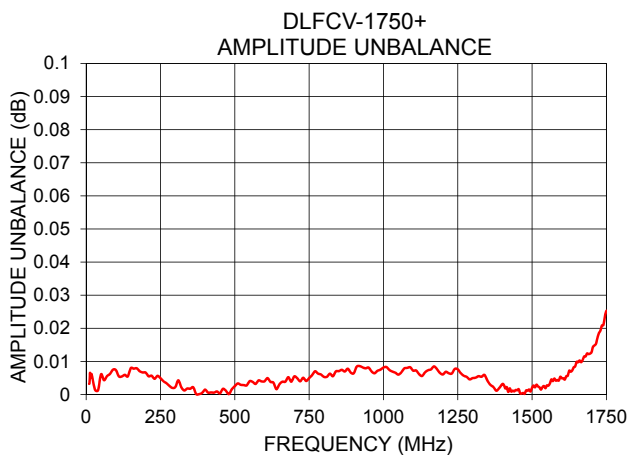
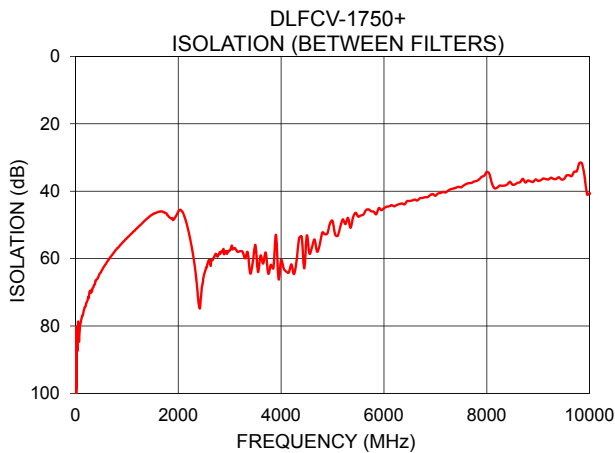
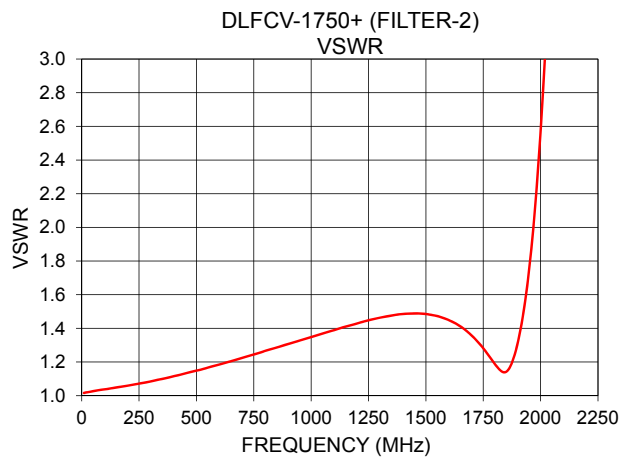
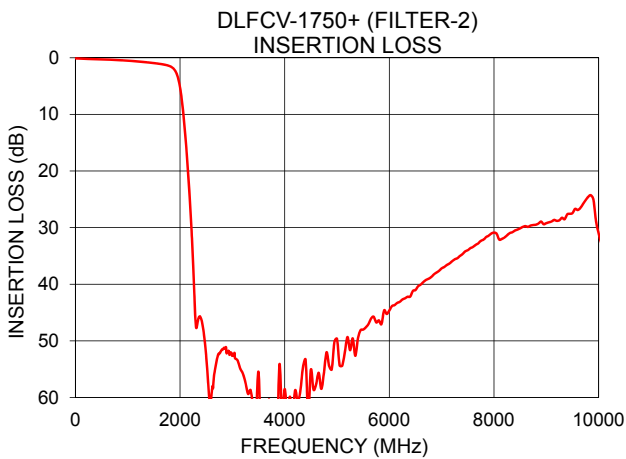
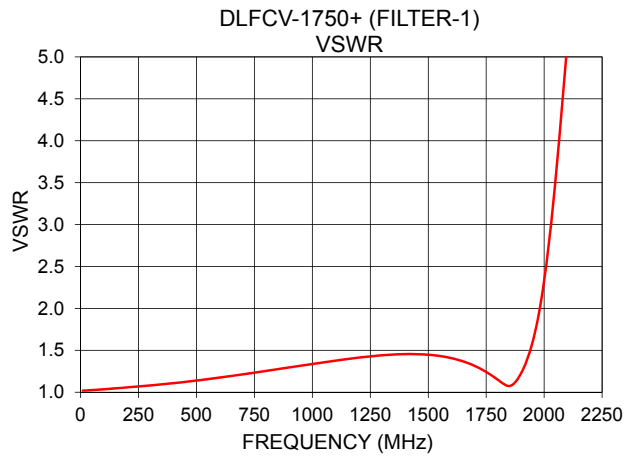
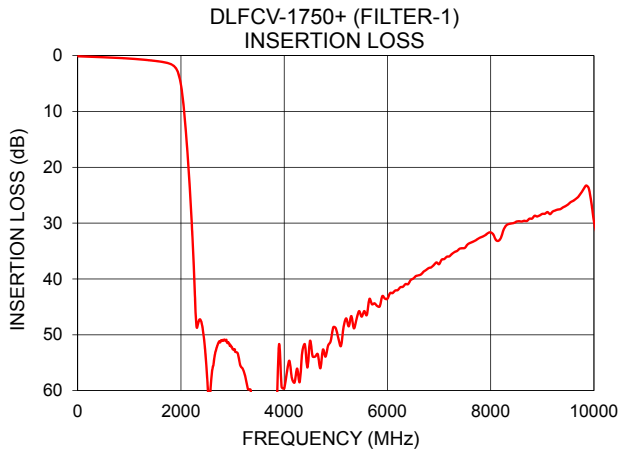

Notes

- A. Performance and quality attributes and conditions not expressly stated in this specification document are intended to be excluded and do not form a part of this specification document.
- B. Electrical specifications and performance data contained in this specification document are based on Mini-Circuit's applicable established test performance criteria and measurement instructions.
- C. The parts covered by this specification document are subject to Mini-Circuits standard limited warranty and terms and conditions (collectively, "Standard Terms"); Purchasers of this part are entitled to the rights and benefits contained therein. For a full statement of the Standard Terms and the exclusive rights and remedies thereunder, please visit Mini-Circuits' website at www.minicircuits.com/MCLStore/terms.jsp



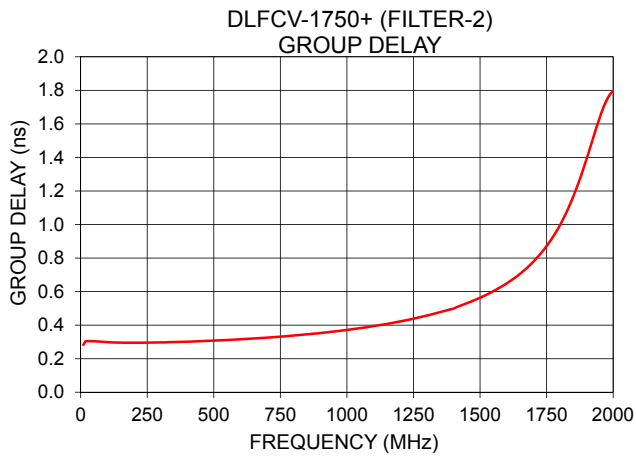
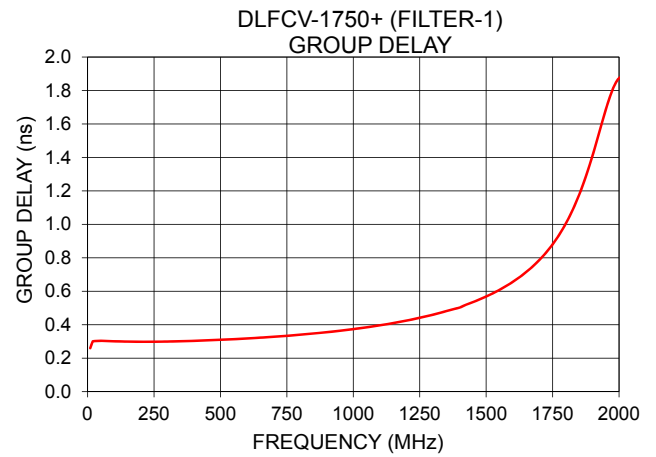
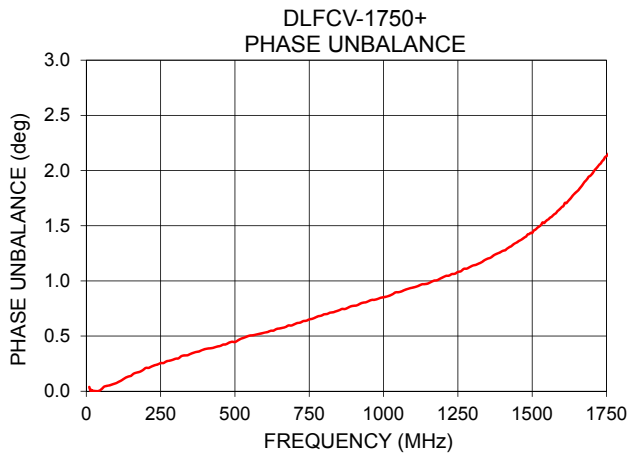

Notes

- A. Performance and quality attributes and conditions not expressly stated in this specification document are intended to be excluded and do not form a part of this specification document.
- B. Electrical specifications and performance data contained in this specification document are based on Mini-Circuit's applicable established test performance criteria and measurement instructions.
- C. The parts covered by this specification document are subject to Mini-Circuits standard limited warranty and terms and conditions (collectively, "Standard Terms"); Purchasers of this part are entitled to the rights and benefits contained therein. For a full statement of the Standard Terms and the exclusive rights and remedies thereunder, please visit Mini-Circuits' website at www.minicircuits.com/MCLStore/terms.jsp



Dual Low Pass Filter

Typical Performance Data

DLFCV-1750+

FREQUENCY (MHz)	INSERTION LOSS (dB)		Isolation (between filters) (dB)	RETURN LOSS (dB)	
	Filter1	Filter2		Filter1	Filter2
10	0.11	0.11	90.80	38.74	41.76
50	0.13	0.14	85.17	38.28	39.14
100	0.15	0.16	80.96	37.29	36.79
150	0.18	0.18	75.60	37.27	36.70
250	0.21	0.21	71.78	40.39	39.81
500	0.29	0.29	63.58	30.69	29.38
750	0.39	0.39	58.08	21.55	21.08
1000	0.53	0.52	53.95	17.26	16.97
1250	0.71	0.70	50.23	15.32	14.83
1500	0.95	0.95	46.86	15.29	14.53
1750	1.35	1.32	46.48	19.54	19.04
1800	1.51	1.47	47.19	23.18	23.41
1900	2.23	2.19	48.59	19.17	19.07
1950	3.21	3.19	47.55	11.78	11.48
2000	5.24	5.21	46.08	6.89	6.79
2100	14.17	13.63	46.64	2.52	2.61
2150	20.69	19.75	48.95	1.84	1.91
2200	28.45	27.11	52.04	1.48	1.52
2210	30.19	28.78	52.66	1.43	1.47
2220	32.03	30.53	53.36	1.39	1.41
2250	38.18	36.44	55.68	1.27	1.28
2300	48.42	47.12	59.97	1.12	1.10
2350	47.38	46.10	65.94	1.00	0.96
2400	47.89	46.03	73.73	0.91	0.85
2500	56.71	52.69	65.02	0.76	0.68
2750	51.19	52.23	59.12	0.54	0.40
3000	52.56	52.64	57.76	0.40	0.25
3250	57.63	57.34	57.98	0.30	0.16
3500	61.13	55.50	55.89	0.24	0.11
3750	61.32	64.31	64.41	0.20	0.08
4000	59.63	58.52	60.44	0.17	0.07
4250	56.06	60.70	64.75	0.16	0.07
4500	51.09	55.09	53.17	0.18	0.08
4750	52.67	55.67	55.94	0.18	0.09
5000	48.85	49.66	48.81	0.19	0.08
5250	48.48	51.64	49.73	0.20	0.08
5500	46.75	48.01	47.54	0.19	0.06
5750	44.37	46.75	45.95	0.19	0.04
6000	43.54	44.63	45.05	0.18	0.01
6200	41.99	43.10	44.52	0.15	0.02
6400	40.93	42.17	43.91	0.14	0.04
6600	39.36	40.06	42.49	0.12	0.07
6800	38.04	38.74	41.78	0.10	0.07
7000	37.35	37.19	41.36	0.09	0.08
7200	35.95	35.94	40.39	0.09	0.06
7400	34.57	34.67	38.96	0.11	0.03
7600	33.54	33.41	37.85	0.14	0.03
7800	32.58	32.13	36.97	0.19	0.11
8000	31.66	30.88	34.28	0.25	0.20
8200	32.58	31.75	38.96	0.31	0.23
8400	30.07	30.52	37.99	0.36	0.26
8600	29.71	29.74	37.48	0.39	0.23
8800	29.19	29.49	36.83	0.40	0.19
9000	28.34	29.22	36.96	0.39	0.11
9200	27.94	28.80	36.50	0.35	0.03
9400	27.18	27.66	35.89	0.32	0.04
9600	26.00	26.89	35.27	0.33	0.05
9800	23.89	24.56	31.67	0.59	0.30
9900	23.78	25.02	35.42	1.31	0.78
10000	29.69	31.02	40.63	0.79	0.23

Dual Low Pass Filter

DLFCV-1750+

Typical Performance Data

FREQUENCY (MHz)	AMPLITUDE UNBALANCE (dB)	PHASE UNBALANCE (deg)	GROUP DELAY (ns)	
			Filter1	Filter2
10	0.00	0.04	0.28	0.26
20	0.01	0.01	0.30	0.30
30	0.00	0.00	0.31	0.30
40	0.00	0.00	0.30	0.30
60	0.00	0.04	0.30	0.30
80	0.01	0.05	0.30	0.30
100	0.01	0.07	0.30	0.30
120	0.01	0.10	0.30	0.30
140	0.01	0.13	0.30	0.30
160	0.01	0.16	0.30	0.30
180	0.01	0.18	0.30	0.30
200	0.01	0.21	0.30	0.30
220	0.01	0.22	0.30	0.30
240	0.01	0.24	0.30	0.30
260	0.00	0.26	0.30	0.30
280	0.00	0.28	0.30	0.30
300	0.00	0.29	0.30	0.30
320	0.00	0.32	0.30	0.30
340	0.00	0.33	0.30	0.30
360	0.00	0.35	0.30	0.30
380	0.00	0.36	0.30	0.30
400	0.00	0.38	0.30	0.30
450	0.00	0.41	0.30	0.31
500	0.00	0.45	0.31	0.31
550	0.00	0.50	0.31	0.31
600	0.00	0.53	0.32	0.32
650	0.00	0.57	0.32	0.32
700	0.01	0.61	0.33	0.33
750	0.00	0.65	0.33	0.33
800	0.01	0.70	0.34	0.34
850	0.01	0.73	0.35	0.35
900	0.01	0.77	0.35	0.36
950	0.01	0.82	0.36	0.36
1000	0.01	0.85	0.37	0.37
1050	0.01	0.90	0.38	0.38
1100	0.01	0.94	0.39	0.40
1150	0.01	0.98	0.41	0.41
1200	0.01	1.03	0.42	0.42
1250	0.01	1.08	0.44	0.44
1300	0.00	1.14	0.46	0.46
1350	0.00	1.20	0.48	0.48
1400	0.00	1.27	0.50	0.50
1450	0.00	1.35	0.53	0.54
1500	0.00	1.43	0.56	0.57
1550	0.00	1.55	0.60	0.61
1600	0.00	1.67	0.65	0.66
1650	0.01	1.81	0.71	0.71
1700	0.01	1.96	0.78	0.79
1710	0.01	2.00	0.79	0.80
1720	0.02	2.03	0.81	0.82
1740	0.02	2.10	0.85	0.86
1750	0.03	2.13	0.87	0.88

Typical Performance Curves

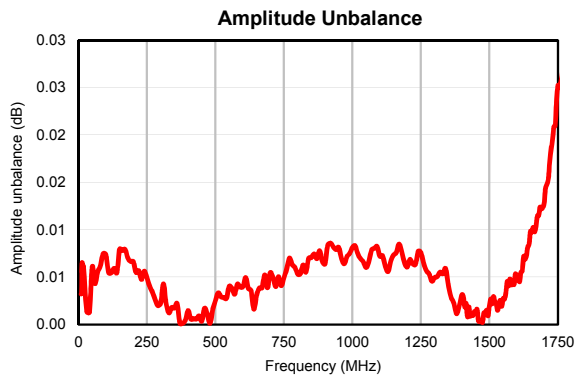
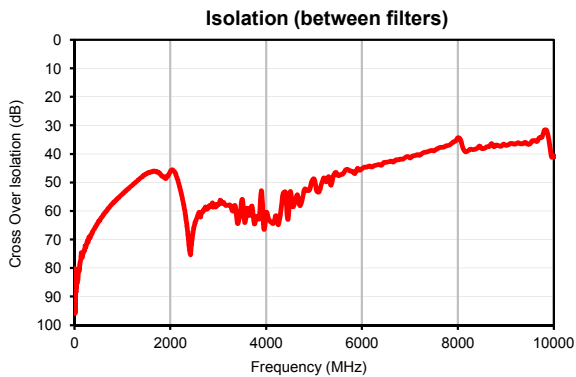
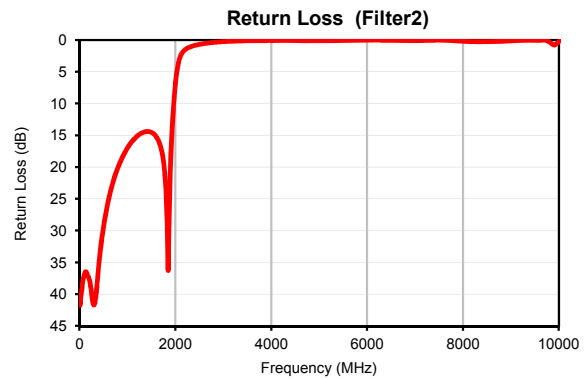
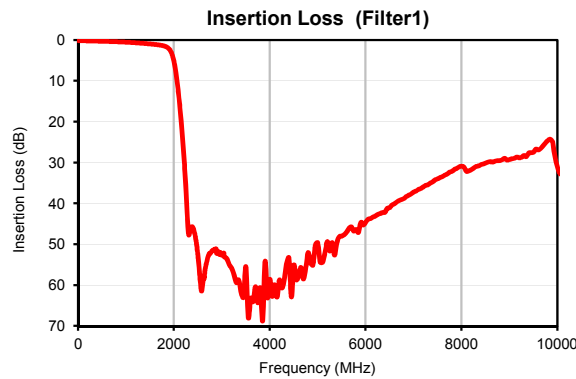
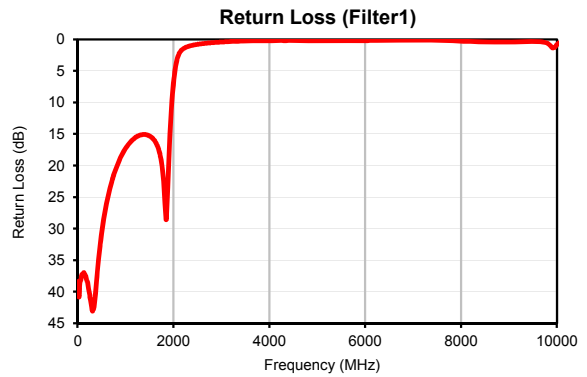
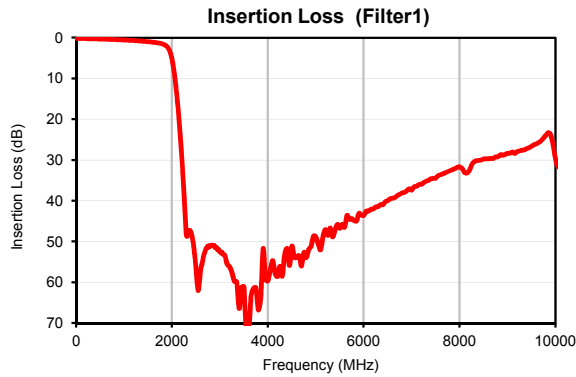

Typical Performance Curves

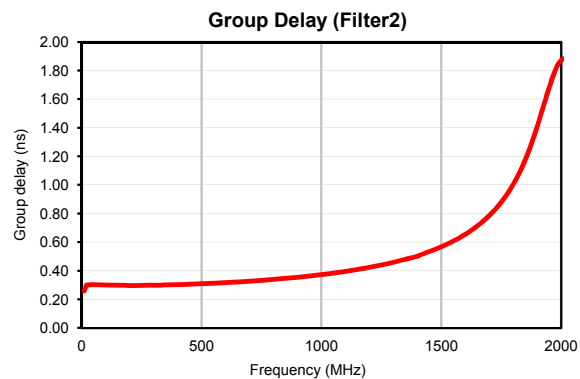
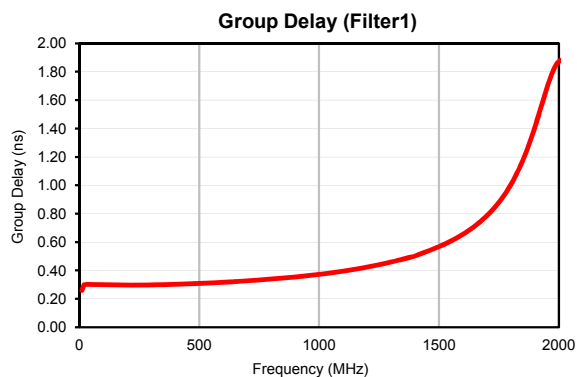
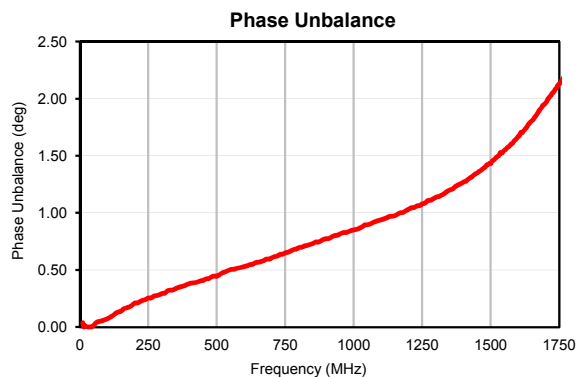

Outline Dimensions

JV1210C-6

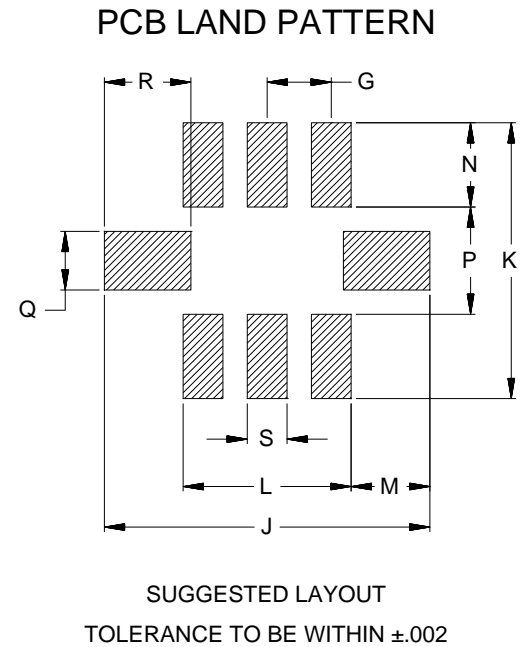
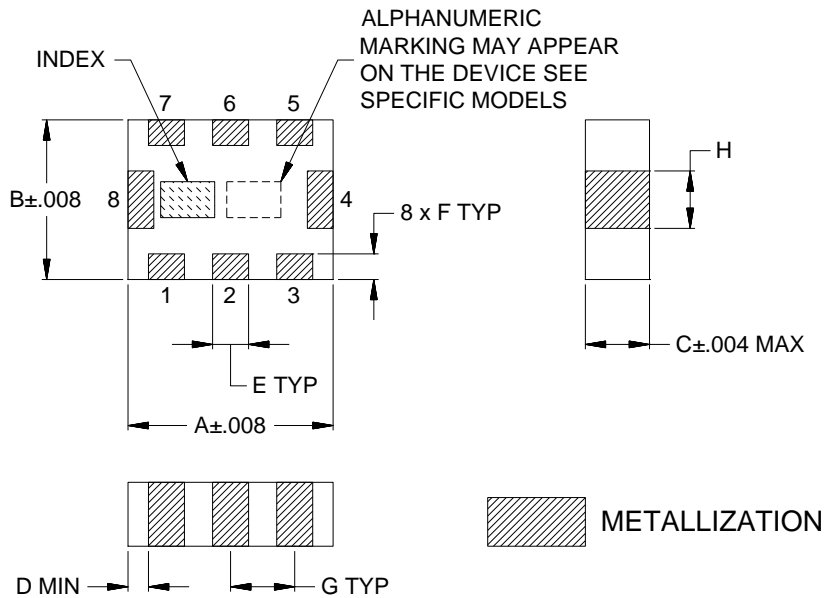

CASE#	A	B	C	D	E	F	G	H	J	K	L	M
JV1210C-6	.126 (3.20)	.098 (2.50)	.039 (1.00)	.004 (0.10)	.022 (0.56)	.016 (0.40)	.039 (1.00)	.035 (0.90)	.200 (5.08)	.170 (4.32)	.103 (2.62)	.048 (1.23)

CASE#	N	P	Q	R	S	WT.GRAM
JV1210C-6	.052 (1.32)	.066 (1.68)	.036 (0.92)	.053 (1.35)	.024 (0.62)	0.03

Dimensions are in inches (mm). Tolerances: 2 Pl. $\pm .01$; 3 Pl. $\pm .005$

Notes:

1. Open style, Ceramic base.
2. Termination finish: **as shown below or indicated on Data Sheet.**
 For RoHS Case Styles: Tin plate over Nickel plate. All models, (+) suffix.
 For RoHS-5 Case Styles: Tin-Lead plate. All models, no (+) suffix.
3. Pad tolerance is non-cumulative. Minimum spacing between each pad is .004.



P.O. Box 350166, Brooklyn, New York 11235-0003 (718) 934-4500 Fax (718) 332-4661 For detailed performance specs & shopping online see Mini-Circuits web site



The Design Engineers Search Engine Provides ACTUAL Data Instantly From MINI-CIRCUITS At: www.minicircuits.com

RF/IF MICROWAVE COMPONENTS

Tape & Reel Packaging TR-F74

DEVICE ORIENTATION IN T&R

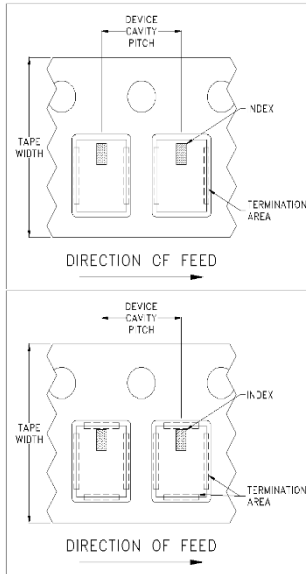

ILLUSTRATION 1

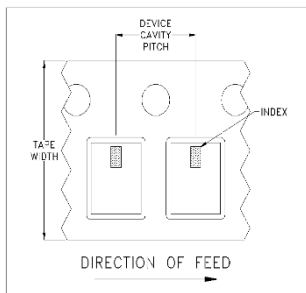

ILLUSTRATION 2

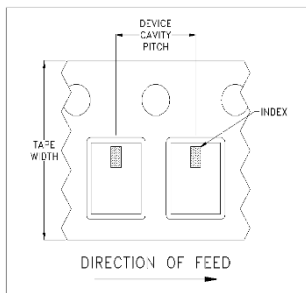

ILLUSTRATION 3

Applicable Case Styles

GE0805C-1
 GE0805C-1AP
 JV1210C-1
 GU2939

Applicable Case Styles

JV1210C
 JV1210C-2
 JV1210C-3
 JV1210C-4
 JV1210C-5
 JV1210C-6
 JV1210C-11

Applicable Case Styles

JC0603C-8
 JC0603C-9
 JV1210C-7
 JV1210C-8
 JV1210C-9
 JV1210C-10
 JV1210C-13
 GE0805C-13
 GE0805C-19
 GE0805C-20

Tape Width, mm	Device Cavity Pitch, mm	Real Size, inches	Devices per Reel	
8	4	7	Small quantity standards (see note)	20
				50
				100
				200
				500
				1000
			Standard	2000
				4000

Note: Small reel availability varies by model. Refer to pricing and availability on individual model dashboard.

Mini-Circuits carrier tape materials provide protection from ESD (Electro-Static Discharge) during handling and transportation. Tapes are static dissipative and comply with industry standards EIA-481/EIA-541.

Go to: www.minicircuits.com/pages/pdfs/tape.pdf



Distribution Centers NORTH AMERICA 800-654-7949 • 417-335-5935 • Fax 417-335-5945 • EUROPE 44-1252-832600 • Fax 44-1252-837010

Mini-Circuits ISO 9001 & ISO 14001 Certified

INTERNET <http://www.minicircuits.com>

P.O. Box 350166, Brooklyn, New York 11235-0003 (718) 934-4500 Fax (718) 332-4661

THIRD ANGLE PROJECTION

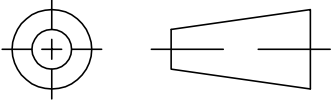

REVISIONS

REV OR	ECN No.	DESCRIPTION	DATE	DR	AUTH
	M169000	NEW RELEASE	AUG 18	DDR	VC

SUGGESTED MOUNTING CONFIGURATION FOR JV1210C-6 CASE STYLE "08FL08" PIN CODE

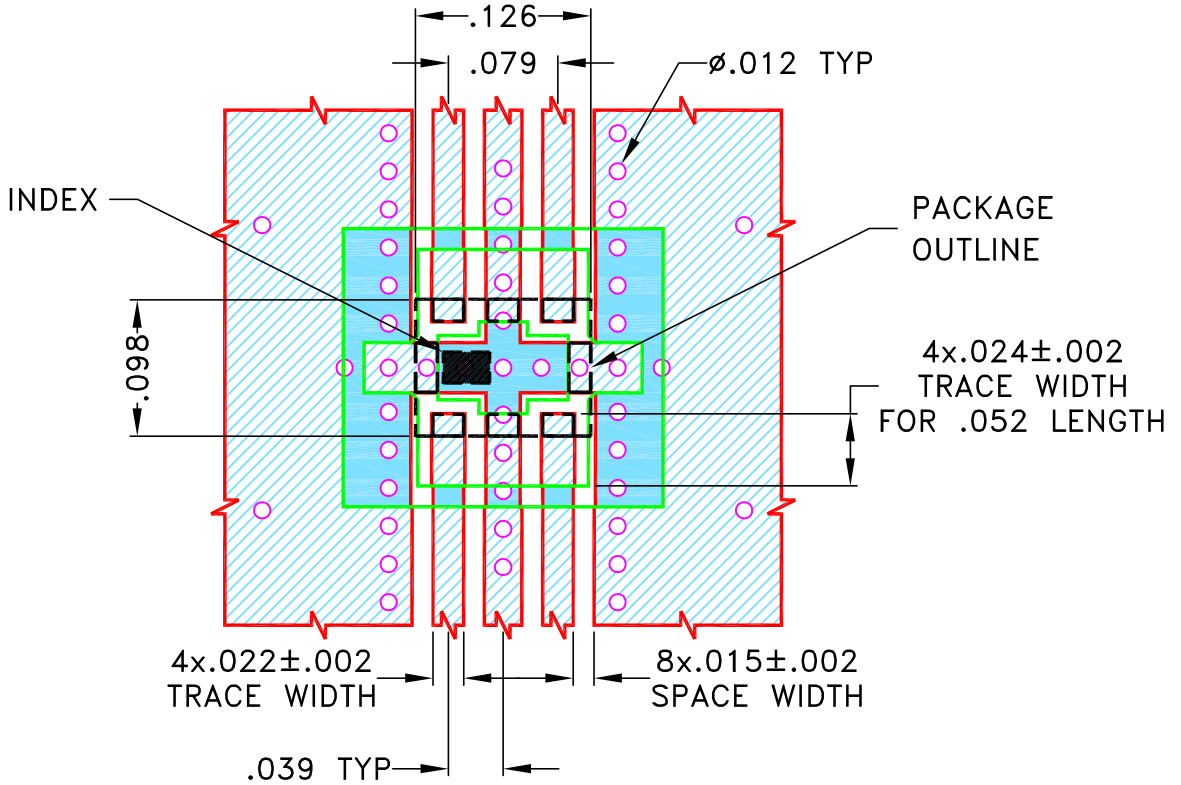

NOTES:

- TRACE WIDTH IS SHOWN FOR ROGERS (R04350B) WITH DIELECTRIC THICKNESS $.010 \pm .001$ ". COPPER: 1/20z. EACH SIDE.
FOR OTHER MATERIALS TRACE WIDTH MAY NEED TO BE MODIFIED.
- BOTTOM SIDE OF THE PCB IS CONTINUOUS GROUND PLANE.



DENOTES PCB COPPER LAYOUT WITH SMOBC (SOLDER MASK OVER BARE COPPER)



DENOTES COPPER LAND PATTERN FREE OF SOLDERMASK

UNLESS OTHERWISE SPECIFIED	INITIALS	DATE
DIMENSIONS ARE IN INCHES	DRAWN DDR	18 AUG 18
TOLERANCES ON:	CHECKED MD	18 AUG 18
2 PL DECIMALS ±	APPROVED RKS	18 AUG 18
3 PL DECIMALS ± .005"		
ANGLES ±		
FRACTIONS ±		



Mini-Circuits®

13 Neptune Avenue
Brooklyn NY 11235

PL, 08FL08, JV1210C-6
DLFCV, TB-1074+, 50 OHM

Mini-Circuits®

THIS DOCUMENT AND ITS CONTENTS ARE THE PROPERTY OF MINI-CIRCUITS. EXCEPT FOR USE EXPRESSLY GRANTED, IN WRITING, TO ITS VENDORS, VENDEE AND THE UNITED STATES GOVERNMENT, MINI-CIRCUITS RESERVES ALL PROPRIETARY DESIGN, USE, MANUFACTURING AND REPRODUCTION RIGHTS THERETO. THESE CONTENTS SHALL NOT BE USED, DUPLICATED OR DISCLOSED TO ANY OUTSIDE PARTY, IN WHOLE OR IN PART, WITHOUT WRITTEN PERMISSION OF MINI-CIRCUITS.

SIZE	CODE IDENT	DRAWING NO:	REV:
A	15542	98-PL-600	OR
FILE:	98PL600	SCALE:	SHEET:
		7:1	1 OF 1

Evaluation Board and Circuit

TB-1074+

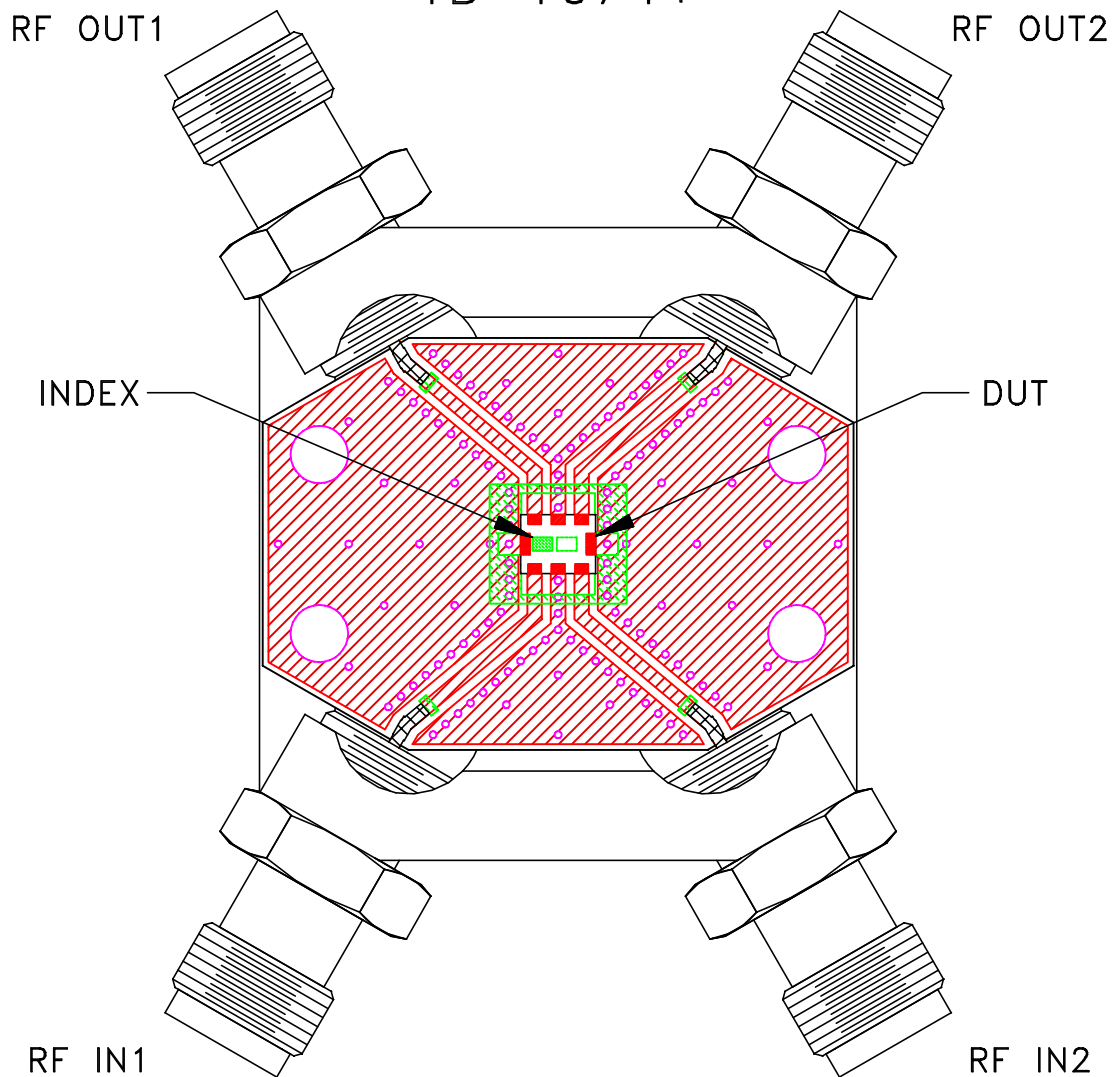

Schematic diagram

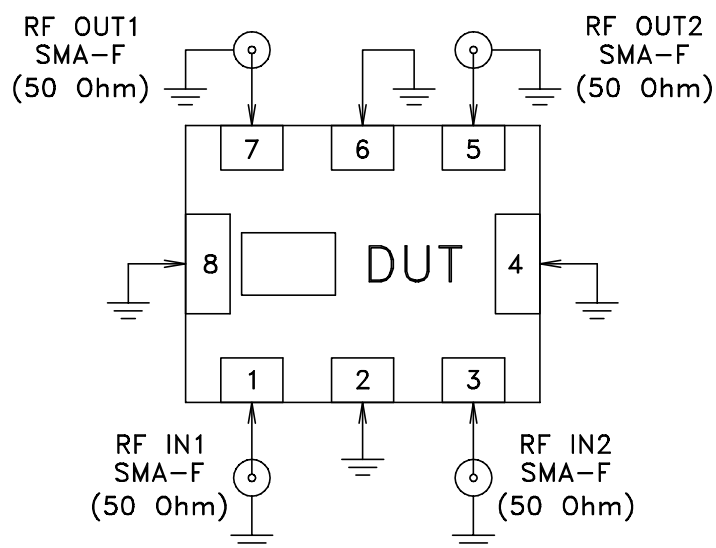

Notes:

1. 50 Ohm SMA Female connectors.
2. PCB Material: ROGERS (R04350B), OR Equivalent
Dielectric Constant=3.48, Thickness=.010inch.

 **Mini-Circuits®**

All Mini-Circuits products are manufactured under exacting quality assurance and control standards, and are capable of meeting published specifications after being subjected to any or all of the following physical and environmental test.

Specification	Test/Inspection Condition	Reference/Spec
Operating Temperature	-55° to 100°C Ambient Environment	Individual Model Data Sheet
Storage Temperature	-55° to 100° C Ambient Environment	Individual Model Data Sheet
Humidity	90 to 95% RH, 240 hours, 50°C	MIL-STD-202, Method 103, Condition A, Except 50°C and end-point electrical test done within 12 hours
Solder Reflow Heat	Sn-Pb Eutetic Process: 225°C peak Pb-Free Process 245° - 250°C peak	J-STD-020, Table 4-1, 4-2 and 5-2, Figure 5-1
Solderability	10X Magnification	J-STD-002, Para 4.2.5, Test S, 95% Coverage
Vibration (High Frequency)	20g peak, 10-2000 Hz, 12 times in each of three perpendicular directions (total 36)	MIL-STD-202, Method 204, Condition D
Mechanical Shock	50g, 11 ms, 1/2-sine, 18 shocks: 3 each direction, each of 3 axes	MIL-STD-202, Method 213, Condition A