



MMIC SURFACE MOUNT

# Directional Coupler

## EDC10-183+

Mini-Circuits

50Ω 10 dB 6 to 18 GHz

### THE BIG DEAL

- Wideband, 6 to 18 GHz
- Low mainline loss, 1.3 dB typ.
- Excellent coupling flatness, ±0.7dB
- Small size, 4x4 mm
- Highly repeatable performance (GaAs based design)
- No external termination required

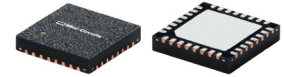

Generic photo used for illustration purposes only

CASE STYLE: DG1847

**+RoHS Compliant**

The +Suffix identifies RoHS Compliance. See our web site for RoHS Compliance methodologies and qualifications

### APPLICATIONS

- Satellite communications
- Wireless infrastructure
- Test and measurements

### PRODUCT OVERVIEW

Mini-Circuits' EDC10-183+ is a 10 dB directional coupler that operates from 6 to 18 GHz packaged in MCLP 4 x 4mm, 24-lead package. It provides excellent coupling flatness over a broad bandwidth and good return loss. This coupler also provides a quadrature phase shift between the signal at the through port and coupler port. Manufacturing using GaAs Technology, this model results in relatively high repeatability in performance.

### KEY FEATURES

Feature	Advantages
Wideband, 6-18 GHz	EDC10-183+ can be used in many applications, saving component count. Also ideal for wideband applications such as military and instrumentation.
Excellent coupling flatness	Excellent coupling flatness yields higher accuracy.
Small size, 4x4 MCLP package.	Tiny footprint saves space in dense layouts while providing low inductance, repeatable transitions, and excellent thermal contact to the PCB.

REV. A  
 ECO-012570  
 EDC10-183+  
 MCL NY  
 220315



ELECTRICAL SPECIFICATIONS<sup>1</sup> AT 25°C

Parameter	Frequency (MHz)	Min.	Typ.	Max.	Unit
Frequency Range		6000		18000	MHz
Mainline Loss	6000 - 10000	—	1.0	2.2	dB
	10000 - 14000	—	1.3	2.3	
	14000 - 16000	—	1.4	2.3	
	16000 - 18000	—	1.5	2.3	
Nominal Coupling	6000 - 10000	9.2	10.3	12.5	dB
	10000 - 14000	9.5	10.0	11.7	
	14000 - 16000	9.7	10.5	11.7	
	16000 - 18000	9.8	10.8	11.9	
Coupling Flatness(±)	6000 - 18000	—	0.7	—	dB
Directivity	6000 - 10000	10	16	—	dB
	10000 - 14000	10	16	—	
	14000 - 16000	9.1	12	—	
	16000 - 18000	8.9	18	—	
Return Loss (Input)	6000 - 10000		24		dB
	10000 - 14000		18		
	14000 - 16000		15		
	16000 - 18000		15		
Return Loss (Output)	6000 - 10000		22		dB
	10000 - 14000		17		
	14000 - 16000		12		
	16000 - 18000		18		
Return Loss (Coupled)	6000 - 10000		24		dB
	10000 - 14000		17		
	14000 - 16000		14		
	16000 - 18000		14		

1. Measured on Mini-Circuits Characterization test board TB-EDC10-183+ with testboard loss deducted.



### MAXIMUM RATINGS

Parameter	Ratings
Operating Temperature	-40°C to 85°C
Storage Temperature	-65°C to 150°C
Input Power	28 dBm (5 minute max.) 25 dBm (continuous)
Power at internal termination	19 dBm (5 minute max.) 16 dBm (continuous)

Permanent damage may occur if any of these limits are exceeded.

### PAD CONNECTIONS

Function	Pad Number
INPUT	5
COUPLED	2
OUTPUT	14
GROUND	Paddle
NC (GROUND EXTERNALLY)	1,3,4,6-13,15-24

### ELECTRICAL SCHEMATIC

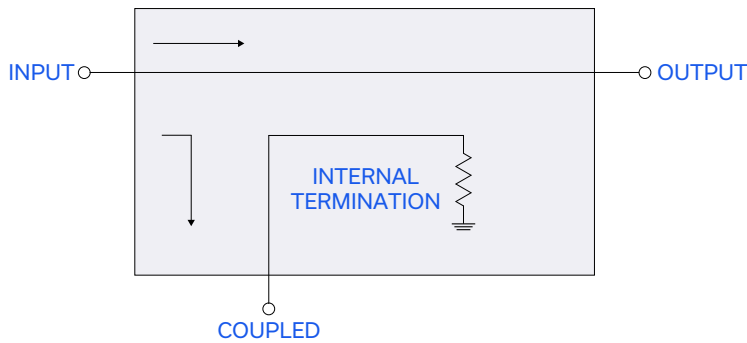

### PRODUCT MARKING

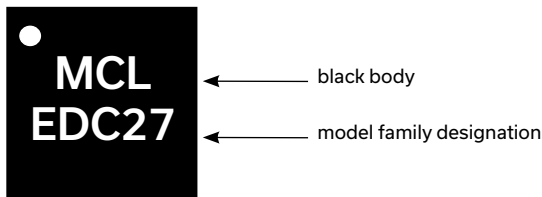

Marking may contain other features or characters for internal lot control



ADDITIONAL DETAILED TECHNICAL INFORMATION IS AVAILABLE ON OUR DASH BOARD. TO ACCESS [CLICK HERE](#)

Performance Data	Data Table Swept Graphs S-Parameter (S3P Files) Data Set (.zip file)
Case Style	DG1847 Plastic package, exposed paddle lead finish: matte-tin
Tape & Reel Standard quantities available on reel	F68 7" reels with 20, 50, 100, 200, 500 or 1K devices
Suggested Layout for PCB Design	PL-614
Evaluation Board	TB-EDC10-183+
Environmental Ratings	ENV08T2

### ESD RATING

Human Body Model (HBM): Class 1B (Pass 500V) in accordance with ANSI/ESD STM 5.1 - 2001

### MSL TEST FLOW CHART

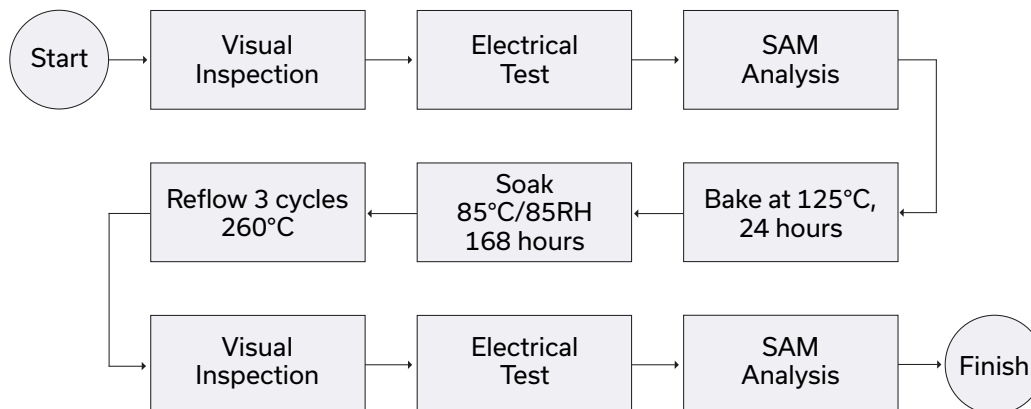

- NOTES**
- A. Performance and quality attributes and conditions not expressly stated in this specification document are intended to be excluded and do not form a part of this specification document.
  - B. Electrical specifications and performance data contained in this specification document are based on Mini-Circuit's applicable established test performance criteria and measurement instructions.
  - C. The parts covered by this specification document are subject to Mini-Circuits standard limited warranty and terms and conditions (collectively, "Standard Terms"); Purchasers of this part are entitled to the rights and benefits contained therein. For a full statement of the standard terms and the exclusive rights and remedies thereunder, please visit Mini-Circuits' website at [www.minicircuits.com/MCLStore/terms.jsp](http://www.minicircuits.com/MCLStore/terms.jsp)

# Directional Coupler

# EDC10-183+

## Typical Performance Data

TEST CONDITIONS: INPUT POWER = 0 dBm @Temperature = +25°C

FREQUENCY (MHz)	INSERTION LOSS (dB)	COUPLING (dB)	DIRECTIVITY (dB)	RETURN LOSS		
				IN	(dB) OUT	CPL
1000	0.25	24.50	33.54	31.29	24.30	33.87
3000	0.61	15.80	19.55	14.03	18.73	13.82
6000	0.77	11.30	18.77	22.56	23.44	22.04
6500	0.81	10.94	20.42	25.32	27.54	24.57
7000	0.84	10.63	20.71	38.48	28.82	33.30
7500	0.89	10.38	19.18	31.27	24.24	31.46
8000	0.94	10.17	17.16	29.87	20.65	37.01
8500	1.03	10.03	15.51	24.67	18.49	25.62
9000	1.15	9.99	14.50	17.34	17.31	16.71
9500	1.33	10.07	13.91	13.19	16.68	12.45
10000	1.47	10.17	13.76	11.26	16.10	10.46
10500	1.50	10.19	14.10	10.94	15.37	10.11
11000	1.42	10.13	14.77	12.16	14.86	11.41
11500	1.28	9.98	15.97	15.41	15.10	15.01
12000	1.16	9.85	17.98	22.28	16.68	24.01
12500	1.14	9.81	20.01	28.84	20.26	31.98
13000	1.16	9.87	19.59	30.57	23.03	22.86
13500	1.22	10.06	16.86	19.28	18.26	16.57
14000	1.38	10.40	14.25	13.32	14.62	12.14
14500	1.47	10.63	12.59	11.74	12.37	10.91
15000	1.37	10.56	12.04	14.68	11.41	13.89
15500	1.30	10.40	12.42	22.21	11.71	19.55
16000	1.48	10.50	13.95	13.27	13.90	11.90
16500	1.66	10.72	16.69	10.45	18.02	9.23
17000	1.52	10.88	21.84	11.72	19.78	10.52
17500	1.25	10.95	22.48	19.25	17.52	17.24
18000	1.19	11.11	16.56	21.51	17.14	19.95
18500	1.28	11.14	13.04	15.91	19.26	14.68
19000	1.29	10.95	11.27	19.97	26.00	16.50
19500	1.36	10.90	10.67	21.57	28.21	15.77
20000	1.63	11.27	10.87	11.95	18.70	10.20



P.O. Box 350166, Brooklyn, New York 11235-0003 (718) 934-4500 • Fax (718) 332-4661 For detailed performance specs & shopping online see Mini-Circuits web site



The Design Engineers Search Engine Provides ACTUAL Data Instantly From MINI-CIRCUITS At: [www.minicircuits.com](http://www.minicircuits.com)

IF/RF MICROWAVE COMPONENTS

REV. OR  
EDC10-183+  
10/31/2018  
Page 1 of 3

# Directional Coupler

# EDC10-183+

## Typical Performance Data

TEST CONDITIONS: INPUT POWER =0 dBm @Temperature = -40°C

FREQUENCY (MHz)	INSERTION LOSS (dB)	COUPLING (dB)	DIRECTIVITY (dB)	RETURN LOSS		
				IN	(dB) OUT	CPL
1000	0.19	24.49	34.44	32.29	24.28	34.63
3000	0.50	15.74	19.49	13.86	18.85	13.72
6000	0.60	11.16	18.86	22.22	22.65	21.80
6500	0.62	10.79	20.95	25.25	26.36	24.41
7000	0.64	10.47	21.18	37.39	27.60	35.14
7500	0.68	10.20	19.35	32.13	23.88	35.57
8000	0.72	9.99	17.53	29.95	20.74	48.73
8500	0.80	9.84	16.13	24.20	18.62	25.38
9000	0.90	9.77	15.08	18.11	17.30	17.75
9500	1.06	9.81	14.22	13.64	16.53	12.98
10000	1.24	9.93	13.73	11.00	15.91	10.18
10500	1.31	9.99	13.88	10.17	15.12	9.34
11000	1.21	9.91	14.54	11.21	14.46	10.47
11500	1.03	9.73	15.84	14.36	14.55	13.95
12000	0.90	9.59	17.82	20.51	15.88	21.92
12500	0.85	9.53	19.92	26.40	19.31	32.42
13000	0.86	9.56	20.16	29.31	23.23	23.13
13500	0.90	9.73	17.58	19.98	18.45	17.03
14000	1.06	10.07	14.53	13.08	14.44	11.99
14500	1.20	10.36	12.44	10.79	12.03	10.11
15000	1.09	10.30	11.70	13.05	10.71	12.49
15500	0.96	10.09	12.03	21.30	11.06	20.21
16000	1.11	10.14	13.48	13.48	13.21	12.33
16500	1.26	10.33	16.19	10.49	17.66	9.40
17000	1.11	10.47	20.68	11.62	21.35	10.63
17500	0.87	10.54	22.96	17.65	18.70	16.70
18000	0.78	10.68	17.56	23.18	17.27	24.80
18500	0.85	10.75	13.40	15.94	18.14	15.47
19000	0.88	10.61	10.99	17.16	22.02	16.10
19500	0.93	10.46	10.07	22.57	27.37	17.60
20000	1.21	10.79	10.36	11.76	19.46	10.24



ISO 9001 ISO 14001 AS 9100 CERTIFIED



P.O. Box 350166, Brooklyn, New York 11235-0003 (718) 934-4500 • Fax (718) 332-4661 For detailed performance specs & shopping online see Mini-Circuits web site



The Design Engineers Search Engine Provides ACTUAL Data Instantly From MINI-CIRCUITS At: [www.minicircuits.com](http://www.minicircuits.com)

IF/RF MICROWAVE COMPONENTS

REV. OR  
EDC10-183+  
10/31/2018  
Page 2 of 3

# Directional Coupler

# EDC10-183+

## Typical Performance Data

TEST CONDITIONS: INPUT POWER = 0 dBm @Temperature = +85°C

FREQUENCY (MHz)	INSERTION LOSS (dB)	COUPLING (dB)	DIRECTIVITY (dB)	RETURN LOSS		
				IN	(dB) OUT	CPL
1000	0.29	24.49	32.27	30.91	24.46	33.27
3000	0.67	15.81	19.77	14.36	18.91	14.15
6000	0.88	11.38	18.64	22.21	23.92	21.73
6500	0.92	11.02	20.23	24.89	28.60	24.12
7000	0.96	10.72	20.61	36.63	30.02	32.22
7500	1.01	10.48	19.24	31.95	24.79	32.01
8000	1.07	10.28	17.16	29.90	20.91	35.47
8500	1.17	10.14	15.36	24.86	18.51	25.74
9000	1.31	10.13	14.23	17.00	17.19	16.43
9500	1.51	10.23	13.65	12.81	16.54	12.17
10000	1.64	10.33	13.60	11.18	16.02	10.45
10500	1.63	10.32	14.12	11.27	15.42	10.48
11000	1.55	10.24	14.92	12.81	15.12	12.11
11500	1.42	10.12	16.14	16.19	15.58	15.86
12000	1.33	10.01	18.01	23.05	17.17	25.14
12500	1.32	9.99	19.87	29.51	20.55	31.10
13000	1.34	10.05	19.21	31.82	22.97	22.70
13500	1.42	10.26	16.46	18.94	18.22	16.37
14000	1.58	10.61	13.91	13.15	14.62	12.07
14500	1.66	10.82	12.37	11.96	12.44	11.22
15000	1.55	10.73	12.02	15.74	11.57	15.04
15500	1.51	10.60	12.66	20.98	12.17	19.26
16000	1.70	10.73	14.41	13.06	14.73	11.84
16500	1.84	10.93	17.36	10.98	19.01	9.76
17000	1.69	11.09	22.16	12.77	19.80	11.50
17500	1.46	11.19	21.38	20.92	17.63	18.75
18000	1.43	11.34	16.16	21.16	17.49	19.98
18500	1.52	11.36	12.89	16.36	19.88	15.17
19000	1.53	11.18	11.21	20.94	27.50	17.32
19500	1.64	11.17	10.71	20.18	27.25	15.60
20000	1.91	11.57	11.14	11.84	18.09	10.24



P.O. Box 350166, Brooklyn, New York 11235-0003 (718) 934-4500 • Fax (718) 332-4661 For detailed performance specs & shopping online see Mini-Circuits web site



The Design Engineers Search Engine Provides ACTUAL Data Instantly From MINI-CIRCUITS At: [www.minicircuits.com](http://www.minicircuits.com)

IF/RF MICROWAVE COMPONENTS

REV. OR  
EDC10-183+  
10/31/2018  
Page 3 of 3

## Typical Performance Curves

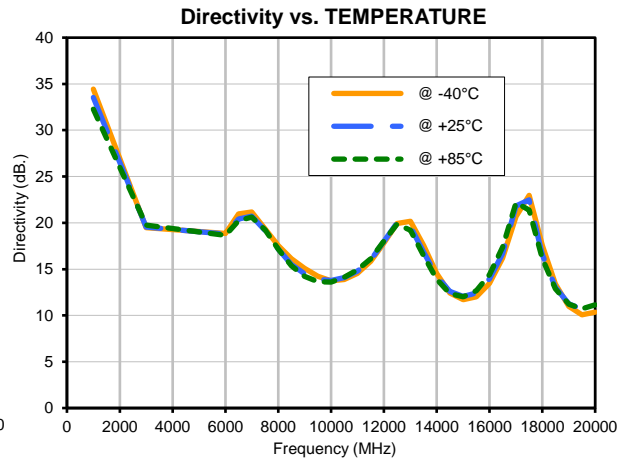
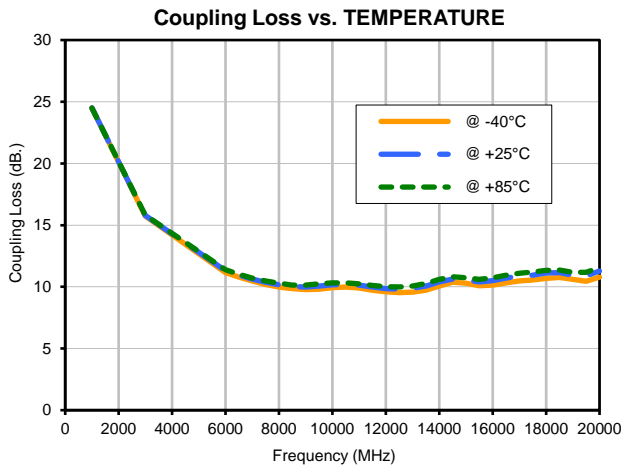
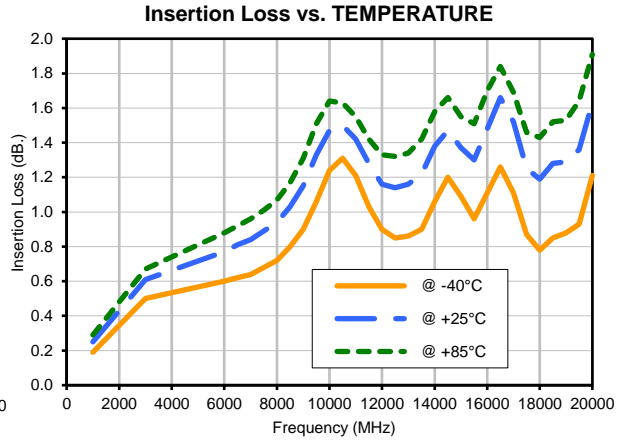
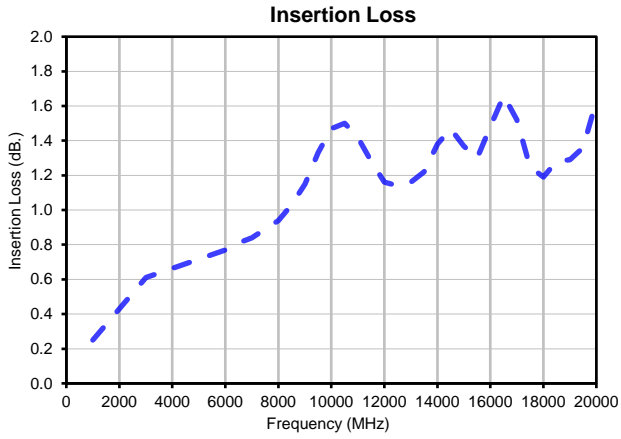

## Typical Performance Curves

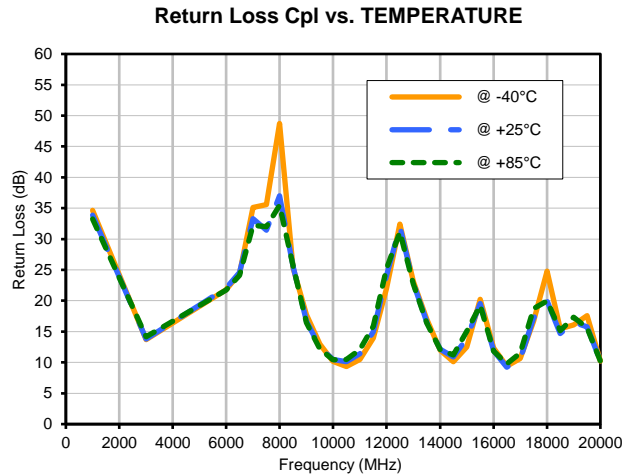
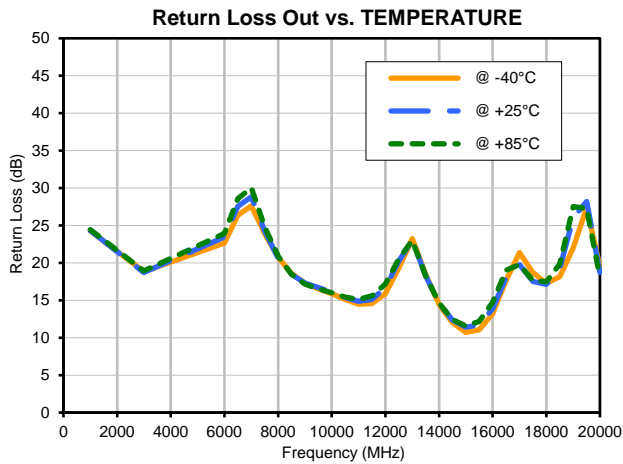
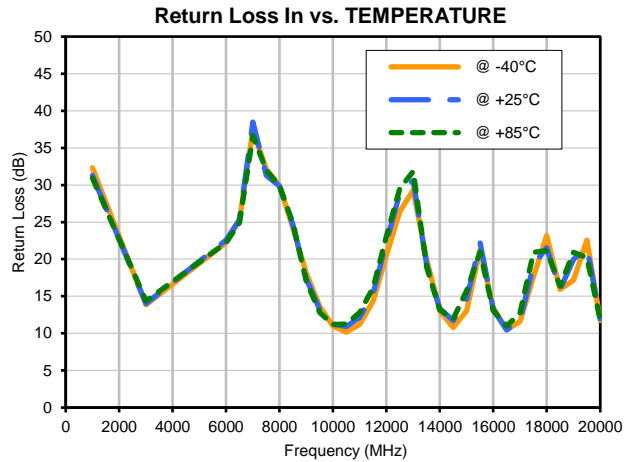
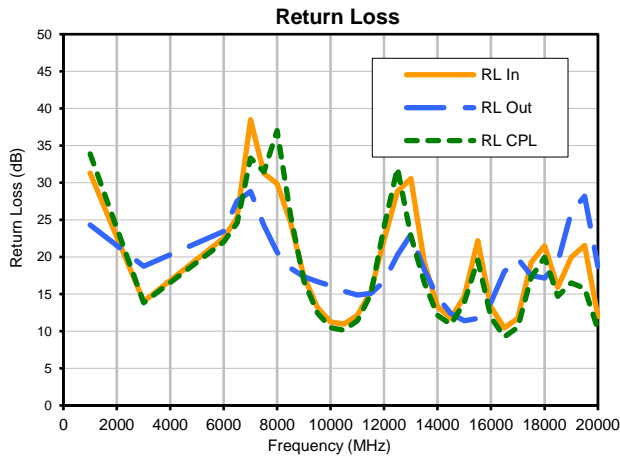

### Outline Dimensions

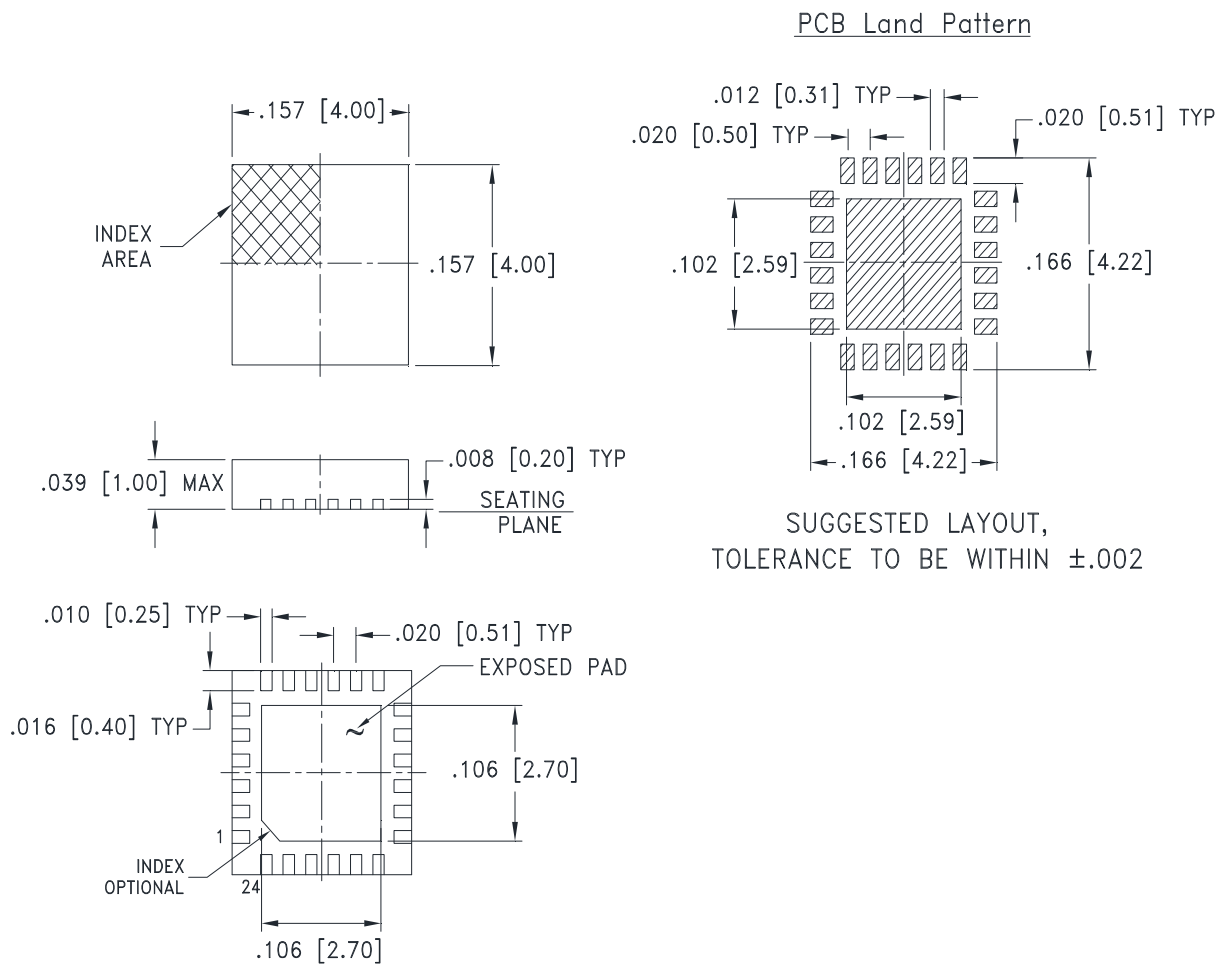

**Weight: .04 Grams**

**Dimensions are in inches (mm). Tolerances: 2 Pl.  $\pm$  .01; 3 Pl.  $\pm$  .005**

#### Notes:

1. Case material: Plastic.
2. Termination finish:
  - For RoHS Case Styles: Tin-Silver alloy plate over Nickel barrier or Matte-Tin. All models, (+) suffix. See model Data sheet.
  - For RoHS-5 Case Styles: Tin-Lead plate. All models, no (+) suffix.

**Mini-Circuits®**  
ISO 9001 ISO 14001 CERTIFIED

ALL NEW  
minicircuits.com

P.O. Box 350166, Brooklyn, New York 11235-0003 (718) 934-4500 Fax (718) 332-4661 For detailed performance specs & shopping online see Mini-Circuits web site



The Design Engineers Search Engine Provides ACTUAL Data Instantly From MINI-CIRCUITS At: [www.minicircuits.com](http://www.minicircuits.com)

RF/IF MICROWAVE COMPONENTS

DG1847 Rev.: AJ (27 FEB 26) ECO-028636 File: DG1847

This document and its contents are the property of Mini-Circuits.

Sheet 1 of 1

# Tape & Reel Packaging TR-F68

## DEVICE ORIENTATION IN T&R

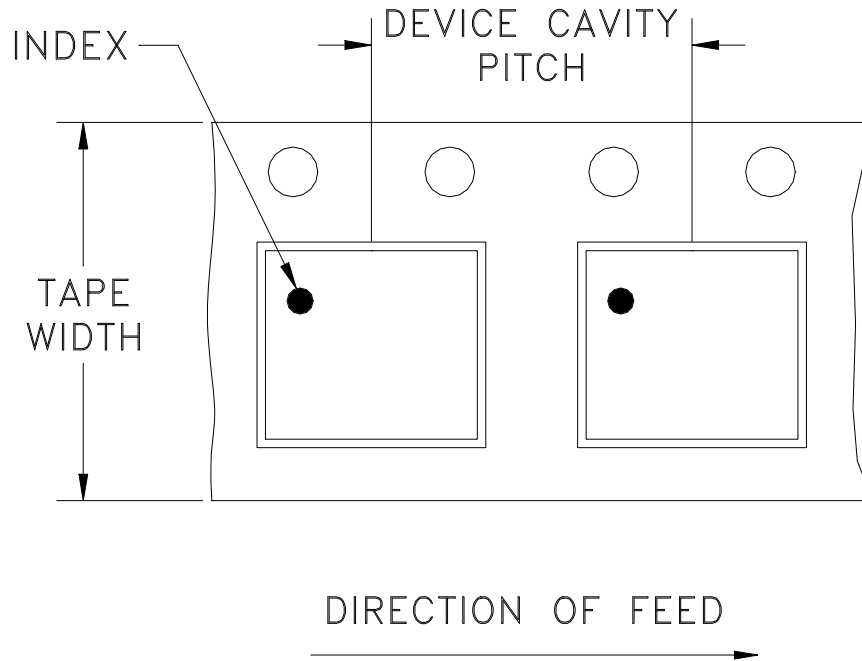

Tape Width, mm	Device Cavity Pitch, mm	Reel Size, inches	Devices per Reel see note	
12	8	7	Small quantity standard	20
				50
				100
				200
				500
		13	Standard	1000
				2000
				4000

Mini-Circuits carrier tape materials provide protection from ESD (Electro-Static Discharge) during handling and transportation. Tapes are static dissipative and comply with industry standards EIA-481/EIA-541.

Go to: [www.minicircuits.com/pages/pdfs/tape.pdf](http://www.minicircuits.com/pages/pdfs/tape.pdf)



INTERNET <http://www.minicircuits.com>

P.O. Box 350166, Brooklyn, New York 11235-0003 (718) 934-4500 Fax (718) 332-4661

Distribution Centers NORTH AMERICA 800-654-7949 • 417-335-5935 • Fax 417-335-5945 • EUROPE 44-1252-832600 • Fax 44-1252-837010

Mini-Circuits ISO 9001 & ISO 14001 Certified

THIRD ANGLE PROJECTION

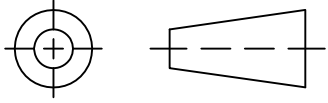

REVISIONS

REV	ECN No.	DESCRIPTION	DATE	DR	AUTH
OR	M171265	NEW RELEASE	12/05/18	ITG	JG

**SUGGESTED MOUNTING CONFIGURATION  
FOR DG1847 CASE STYLE, "24DC04" PIN CODE**

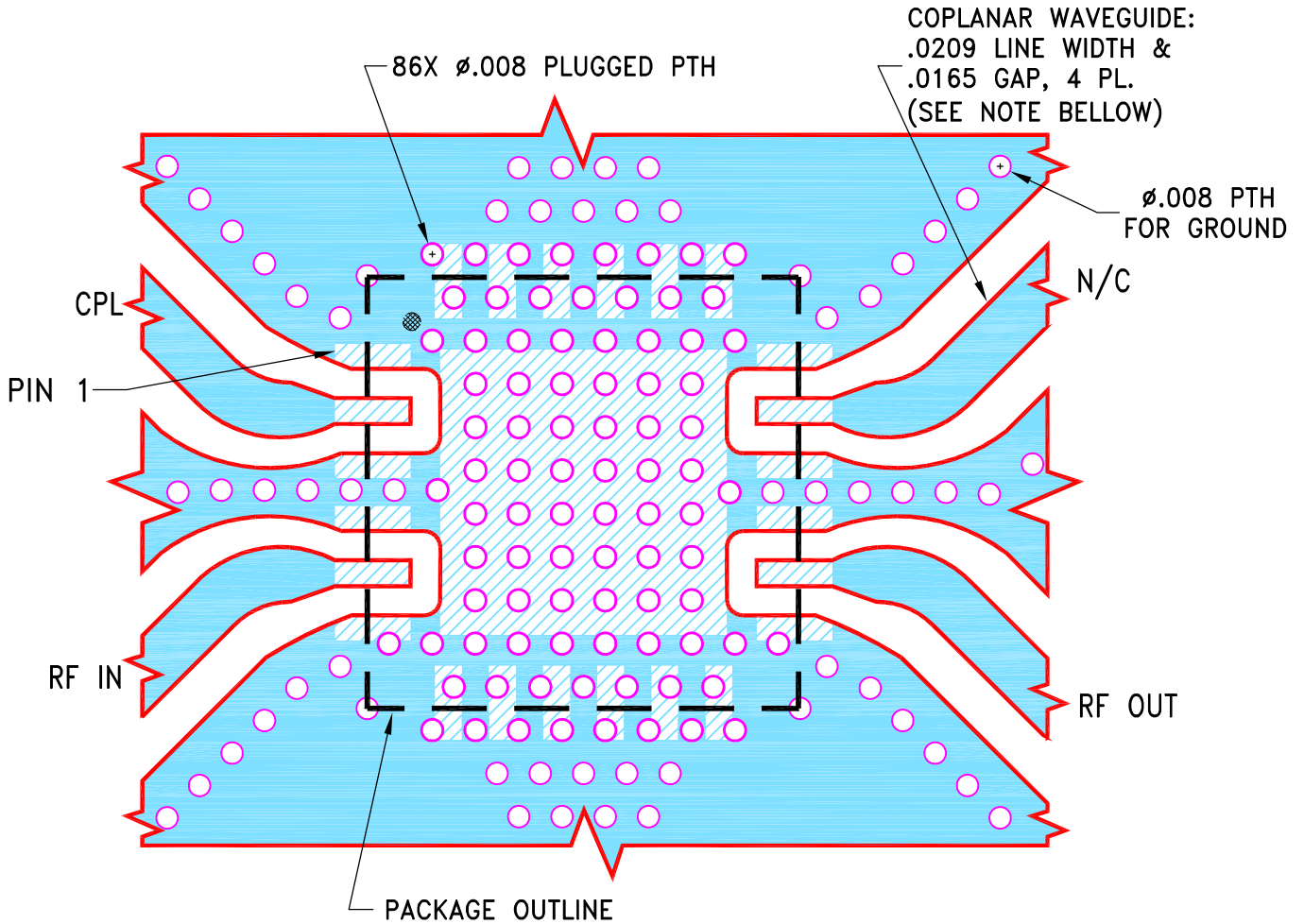

NOTES:

- TRACE WIDTH AND GAP ARE SHOWN FOR ROGERS RO4350B WITH DIELECTRIC THICKNESS .010"±.001". COPPER: 1 OZ. EACH SIDE. FOR OTHER MATERIALS TRACE WIDTH AND GAP MAY NEED TO BE MODIFIED.
- BOTTOM SIDE OF THE PCB IS CONTINUOUS GROUND PLANE.
- UNIT LAND PATTERN WAS OPTIMIZED FOR BETTER PERFORMANCE.

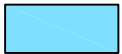

DENOTES PCB COPPER LAYOUT WITH SMOBC (SOLDER MASK OVER BARE COPPER).

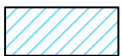

DENOTES COPPER LAND PATTERN FREE OF SOLDER MASK.

UNLESS OTHERWISE SPECIFIED	INITIALS	DATE
DIMENSIONS ARE IN INCHES TOLERANCES ON: 2 PL DECIMALS ± 3 PL DECIMALS ± .005 ANGLES ± FRACTIONS ±	DRAWN	ITG 11/30/18
	CHECKED	GF 12/05/18
	APPROVED	JG 12/05/18



**Mini-Circuits®**

13 Neptune Avenue  
Brooklyn NY 11235

PL, 24DC04, DG1847, TB-EDC10-183+/273+

SIZE A	CODE IDENT 15542	DRAWING NO: 98-PL-614	REV: OR
FILE: 98PL614	SCALE: 15:1	SHEET: 1 OF 1	

Mini-Circuits®  
THIS DOCUMENT AND ITS CONTENTS ARE THE PROPERTY OF MINI-CIRCUITS. EXCEPT FOR USE EXPRESSLY GRANTED, IN WRITING, TO ITS VENDORS, VENDEE AND THE UNITED STATES GOVERNMENT, MINI-CIRCUITS RESERVES ALL PROPRIETARY DESIGN, USE, MANUFACTURING AND REPRODUCTION RIGHTS THERETO. THESE CONTENTS SHALL NOT BE USED, DUPLICATED OR DISCLOSED TO ANY OUTSIDE PARTY, IN WHOLE OR IN PART, WITHOUT WRITTEN PERMISSION OF MINI-CIRCUITS.

# Evaluation Board and Circuit

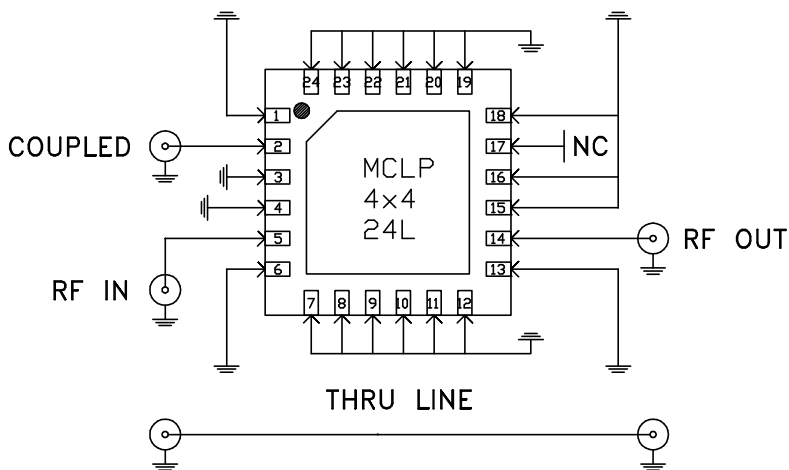
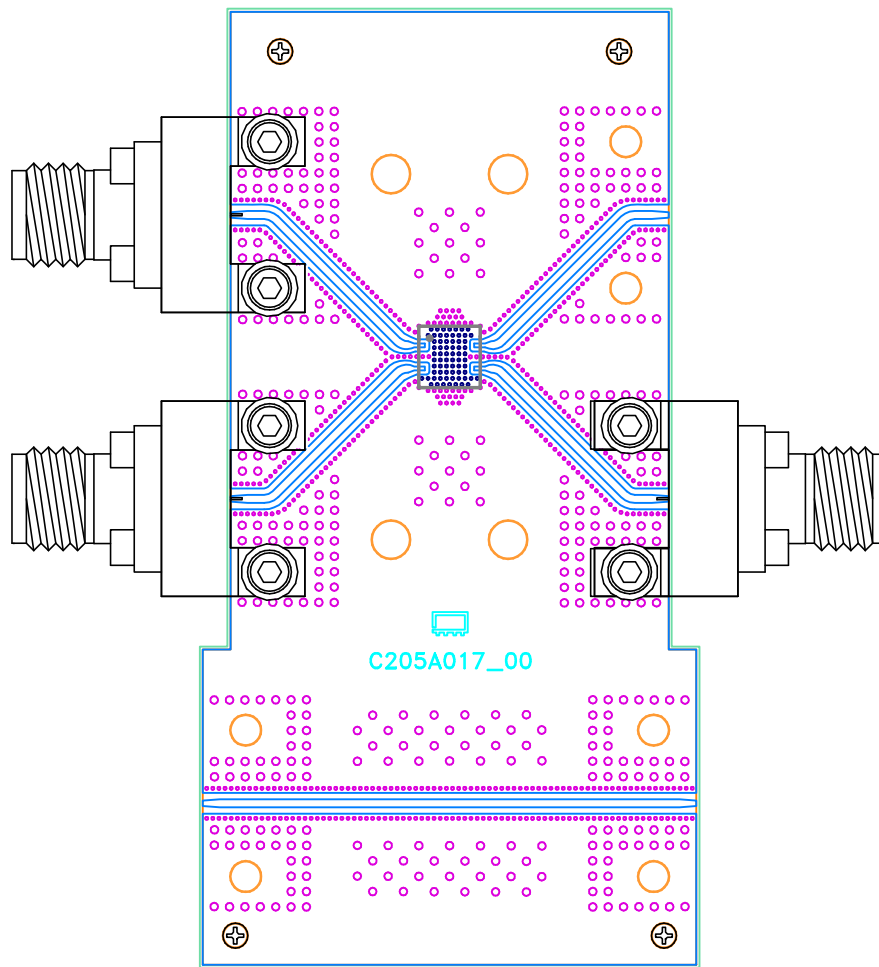

Schematic Diagram

Function	Pad
COUPLED	2
RF IN	5
RF OUT	14
GND	1,3,4,6,7,8,9,10,11, 12,13,15,16,18,19, 20,21,22,23,24
NC	17

## NOTES:

- 2.92 mm Female Connectors.
- PCB Material: Roger R04350B or equivalent, Dielectric constant=3.5, Thickness=0.010 inch

 **Mini-Circuits®**

All Mini-Circuits products are manufactured under exacting quality assurance and control standards, and are capable of meeting published specifications after being subjected to any or all of the following physical and environmental test.

Specification	Test/Inspection Condition	Reference/Spec
Operating Temperature	-45° to 85°C or -40° to 85°C Ambient Environment	Individual Model Data Sheet
Storage Temperature	-65° to 150° C Ambient Environment	Individual Model Data Sheet
Thermal Shock	-55° to 100°C, 100 cycles	MIL-STD-202, Method 107, Condition A-3, except +100°C
Mechanical Shock	1.5Kg, 0.5 ms, 5 shock pulses, Y1 direction only	MIL-STD-883, Method 2002, Condition B, except Y1 direction only
Vibration (Variable Frequency)	50g peak	MIL-STD-883, Method 2007, Condition B
Autoclave	15 psig, 100% RH, 121°C, 96 hours	JESD22-A102, Condition C
HAST	130°C, 85% RH, 96 hours	JESD22-A110
Solderability	10X Magnification	J-STD-002, Para 4.2.5, Test S, 95% Coverage
Solder Reflow Heat	Sn-Pb Eutetic Process: 240°C peak Pb-Free Process: 260°C peak	J-STD-020, Table 4-1, 4-2 and 5-2; Figure 5-1
Moisture Sensitivity: Level 1	Bake at 125°C for 24 hours Soak at 85°C/85% RH for 168 hours, Reflow 3 cycles at 260°C peak	J-STD-020
Marking Resistance to Solvents	Isopropyl alcohol + mineral spirits at 25°C; terpene defluxer at 25°C; distilled water + proylene glycol monomethyl ether +	MIL-STD-202, Method 215



All Mini-Circuits products are manufactured under exacting quality assurance and control standards, and are capable of meeting published specifications after being subjected to any or all of the following physical and environmental test.

<b>Specification</b>	<b>Test/Inspection Condition</b>	<b>Reference/Spec</b>
	monoethanolamine at 63°C to 70°C	