



MMIC SURFACE MOUNT

Directional Coupler

EDC21-24+

50Ω 21 dB 4 to 20 GHz

THE BIG DEAL

- Wideband, 4 to 20 GHz
- Excellent Coupling Flatness 21 ± 2 dB Typ.
- Highly Repeatable Performance (GaAs Based Design)
- Small Size, 4x4 mm
- No External Termination Required

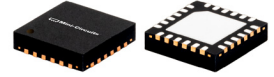

Generic photo used for illustration purposes only

CASE STYLE: DG1847

+RoHS Compliant

The +Suffix identifies RoHS Compliance. See our website for RoHS Compliance methodologies and qualifications

APPLICATIONS

- Satellite Communications
- Wireless Infrastructure
- Test and Measurement

PRODUCT OVERVIEW

Mini-Circuits' EDC21-24+ is a 21 dB directional coupler that operates from 4 to 20 GHz and is packaged in an MCLP 4x4 mm, 24-lead package. It provides excellent coupling flatness over a broad bandwidth and good return loss. This coupler also provides a quadrature phase shift between the signal at the through port and coupler port. Manufactured using GaAs Technology, this model is highly repeatable in volume manufacturing.

KEY FEATURES

Feature	Advantages
Wideband, 4 to 20 GHz	EDC21-24+ can be used in many applications, saving component count. Also ideal for wideband applications such as military and instrumentation.
Excellent Coupling Flatness	Excellent coupling flatness yields higher accuracy.
Small Size, 4x4 mm MCLP Package	Tiny footprint saves space in dense layouts while providing low inductance, repeatable transitions, and excellent thermal contact to the PCB.

REV. A
ECO-012570
EDC21-24+
MCL NY
250904



ELECTRICAL SPECIFICATIONS¹ AT +25°C

Parameter	Frequency (MHz)	Min.	Typ.	Max.	Unit
Frequency Range		4000		20000	MHz
Mainline Loss	4000 - 8000		0.4	1.0	dB
	8000 - 10000		0.7	1.4	
	10000 - 15000		0.8	1.5	
	15000 - 20000		0.9	2.0	
Nominal Coupling	4000 - 8000	18.7	22	25.8	dB
	8000 - 10000	17.8	21	24.6	
	10000 - 15000	18.0	21	24.8	
	15000 - 20000	17.5	21	24.2	
Coupling Flatness (\pm)	4000 - 20000		2.0		dB
Directivity	4000 - 8000	17.2	21		dB
	8000 - 10000	12.5	19		
	10000 - 15000	11	16		
	15000 - 20000	9.1	14		
Return Loss (Input)	4000 - 8000		26		dB
	8000 - 10000		16		
	10000 - 15000		17		
	15000 - 20000		21		
Return Loss (Output)	4000 - 8000		26		dB
	8000 - 10000		16		
	10000 - 15000		17		
	15000 - 20000		21		
Return Loss (Coupled)	4000 - 8000		19		dB
	8000 - 10000		16		
	10000 - 15000		15		
	15000 - 20000		21		

1. Measured on Mini-Circuits characterization test board TB-978+ with test board loss deducted.



ABSOLUTE MAXIMUM RATINGS

Parameter	Ratings
Operating Temperature	-40°C to +85°C
Storage Temperature	-65°C to +150°C
Input Power	+32.5 dBm (5 minutes max.) +29.5 dBm (continuous)
Power at Internal Termination	+15 dBm (5 minutes max.) +12 dBm (continuous)

Permanent damage may occur if any of these limits are exceeded.

PAD CONNECTIONS

Function	Pad Number
INPUT	3
COUPLED	7
OUTPUT	16
GROUND	1,2,4-6,8-15, 17-24 & paddle

ELECTRICAL SCHEMATIC

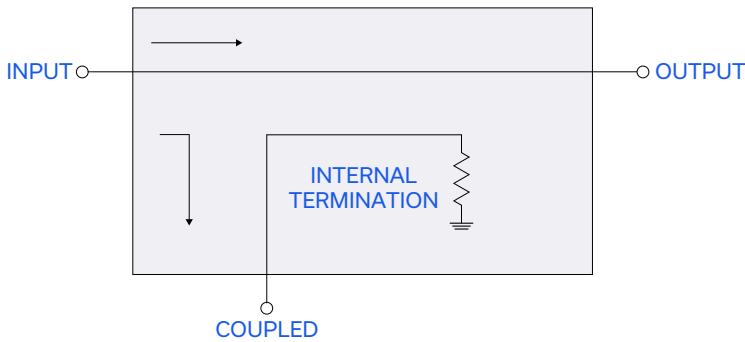

PRODUCT MARKING

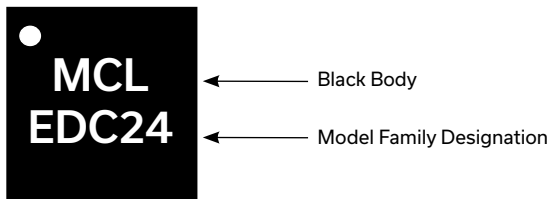

Marking may contain other features or characters for internal lot control.



ADDITIONAL DETAILED TECHNICAL INFORMATION IS AVAILABLE ON OUR DASHBOARD. TO ACCESS [CLICK HERE](#)

Performance Data	Data Table Swept Graphs S-Parameter (S3P Files) Data Set (.zip file)
Case Style	DG1847 Plastic package, exposed paddle Lead Finish: Matte-Tin
Tape & Reel Standard Quantities Available on Reel	F68 7" Reels with 20, 50, 100, 200, 500 or 1000 devices
Suggested Layout for PCB Design	PL-532
Evaluation Board	TB-978+
Environmental Ratings	ENV08T2

ESD RATING

Human Body Model (HBM): Class 1B (Pass 500 V) in accordance with ANSI/ESD STM 5.1 - 2001

MSL RATING

Moisture Sensitivity: MSL1 in accordance with IPC/JEDEC J-STD-020E /JEDEC J-STD-033C

MSL TEST FLOW CHART

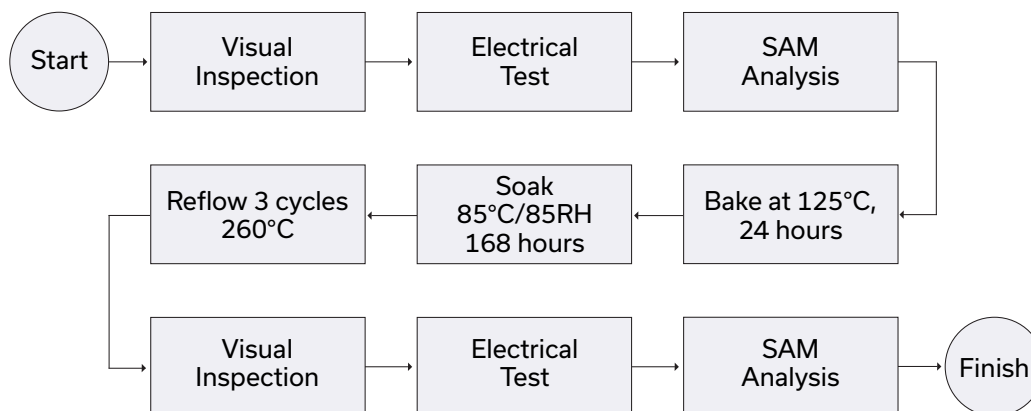

NOTES

- A. Performance and quality attributes and conditions not expressly stated in this specification document are intended to be excluded and do not form a part of this specification document.
- B. Electrical specifications and performance data contained in this specification document are based on Mini-Circuit's applicable established test performance criteria and measurement instructions.
- C. The parts covered by this specification document are subject to Mini-Circuits standard limited warranty and terms and conditions (collectively, "Standard Terms"); Purchasers of this part are entitled to the rights and benefits contained therein. For a full statement of the standard terms and the exclusive rights and remedies thereunder, please visit Mini-Circuits' website at www.minicircuits.com/terms/viewterm.html

Directional Coupler

EDC21-24+

Typical Performance Data

TEST CONDITIONS: INPUT POWER = 0 dBm @Temperature = +25°C

FREQUENCY (MHz)	INSERTION LOSS (dB)	COUPLING (dB)	DIRECTIVITY (dB)	RETURN LOSS		
				IN	(dB) OUT	CPL
3000	0.30	26.28	24.68	22.42	22.37	31.53
3500	0.31	25.18	24.12	22.66	22.74	28.11
4000	0.32	24.30	23.62	23.47	23.52	24.68
4500	0.33	23.59	23.01	25.66	25.62	21.93
5000	0.34	23.01	22.47	30.87	31.01	19.80
5500	0.35	22.55	21.91	42.51	42.54	18.40
6000	0.38	22.19	21.70	26.44	26.26	17.66
6500	0.43	21.89	21.70	21.86	21.72	17.68
7000	0.46	21.65	21.86	20.07	19.82	18.53
7500	0.49	21.45	22.12	19.64	19.43	19.48
8000	0.51	21.31	22.20	19.59	19.45	19.17
8500	0.54	21.23	21.69	18.69	18.59	17.85
9000	0.60	21.21	20.61	16.68	16.43	16.57
9500	0.70	21.24	19.31	14.48	14.10	15.98
10000	0.80	21.30	17.82	12.76	12.34	15.83
10500	0.85	21.30	16.65	12.16	11.82	16.06
11000	0.82	21.24	15.83	12.89	12.65	16.92
11500	0.72	21.16	15.52	15.44	15.47	18.20
12000	0.65	21.13	15.88	20.09	20.67	18.65
12500	0.63	21.20	17.02	25.70	25.86	17.08
13000	0.65	21.33	18.40	27.99	25.00	14.81
13500	0.69	21.45	18.01	22.80	20.71	13.46
14000	0.74	21.54	15.87	18.61	17.91	13.09
14500	0.76	21.49	13.96	18.73	18.65	13.95
15000	0.74	21.37	13.19	27.10	27.14	15.85
15500	0.80	21.31	13.50	22.52	20.41	18.14
16000	0.94	21.28	14.52	15.05	14.44	20.29
16500	0.97	21.20	15.65	13.66	13.37	20.58
17000	0.90	21.12	16.43	15.89	15.57	21.72
17500	0.81	21.03	15.33	24.14	22.47	24.86
18000	0.81	20.89	13.36	28.56	24.37	39.71
18500	0.83	20.68	11.90	23.11	21.56	24.43
19000	0.84	20.41	11.16	28.96	23.34	17.64
19500	0.89	20.24	10.90	22.17	18.36	14.92
20000	1.01	20.17	11.27	15.77	14.20	14.33
21000	0.98	19.81	12.87	19.67	18.33	21.28
22000	1.08	19.36	11.04	16.26	15.03	15.66
23000	1.12	18.45	8.65	20.39	19.73	13.25
24000	1.29	17.96	8.80	14.83	14.47	27.31



P.O. Box 350166, Brooklyn, New York 11235-0003 (718) 934-4500 • Fax (718) 332-4661 For detailed performance specs & shopping online see Mini-Circuits web site



The Design Engineers Search Engine Provides ACTUAL Data Instantly From MINI-CIRCUITS At: www.minicircuits.com

IF/RF MICROWAVE COMPONENTS

REV. OR
EDC21-24+
1/22/2018
Page 1 of 3

Typical Performance Data

TEST CONDITIONS: INPUT POWER =0 dBm @Temperature = -40°C

FREQUENCY (MHz)	INSERTION LOSS (dB)	COUPLING (dB)	DIRECTIVITY (dB)	RETURN LOSS		
				IN	(dB) OUT	CPL
3000	0.17	26.20	25.48	20.63	20.52	30.78
3500	0.17	25.08	23.38	20.94	20.54	27.34
4000	0.16	24.17	23.64	22.89	22.68	24.03
4500	0.15	23.43	23.69	27.24	26.21	21.40
5000	0.15	22.84	24.49	31.23	30.18	20.08
5500	0.15	22.35	24.33	37.09	35.52	18.53
6000	0.16	21.95	23.50	32.04	31.64	17.02
6500	0.19	21.63	22.11	22.27	21.96	16.97
7000	0.23	21.38	21.19	18.84	18.72	18.19
7500	0.25	21.17	21.58	18.60	18.46	18.55
8000	0.24	20.98	22.32	20.09	20.15	18.95
8500	0.25	20.88	23.89	20.26	20.50	18.52
9000	0.31	20.86	22.27	17.19	17.33	15.32
9500	0.42	20.89	19.87	13.95	13.96	15.80
10000	0.57	20.94	17.83	11.54	11.36	14.51
10500	0.62	20.97	16.54	10.90	10.50	15.44
11000	0.56	20.92	15.61	11.50	11.06	17.15
11500	0.42	20.73	15.55	14.82	14.51	16.92
12000	0.29	20.62	16.72	22.39	22.72	20.91
12500	0.27	20.79	18.43	32.10	34.67	15.99
13000	0.31	20.95	19.04	22.59	21.66	13.57
13500	0.38	21.08	16.62	16.61	16.11	12.61
14000	0.40	21.08	14.94	16.89	15.99	12.38
14500	0.35	20.92	14.30	22.24	21.35	14.66
15000	0.35	20.85	14.54	29.56	25.41	13.97
15500	0.40	20.85	14.47	22.75	20.21	16.42
16000	0.48	20.78	14.35	17.58	16.41	21.82
16500	0.57	20.71	14.75	13.47	12.94	16.68
17000	0.56	20.67	16.69	12.53	12.04	18.32
17500	0.44	20.58	17.91	16.94	15.93	33.99
18000	0.40	20.45	14.99	22.04	18.49	22.48
18500	0.53	20.29	11.45	13.12	12.66	22.00
19000	0.50	20.20	9.84	14.80	13.72	10.57
19500	0.50	20.09	9.81	24.64	16.31	8.54
20000	0.72	19.80	10.77	12.19	10.71	21.71
21000	0.52	19.42	14.32	19.62	15.70	34.82
22000	0.77	18.96	10.01	10.79	10.74	16.04
23000	0.56	18.12	8.42	27.41	27.35	10.26
24000	0.65	17.85	10.28	22.58	24.45	20.59

Directional Coupler

EDC21-24+

Typical Performance Data

TEST CONDITIONS: INPUT POWER = 0 dBm @Temperature = +85°C

FREQUENCY (MHz)	INSERTION LOSS (dB)	COUPLING (dB)	DIRECTIVITY (dB)	RETURN LOSS		
				IN	(dB) OUT	CPL
3000	0.39	26.33	24.53	22.14	21.94	34.63
3500	0.40	25.25	23.25	23.36	22.86	29.07
4000	0.42	24.39	22.57	25.52	24.71	26.04
4500	0.44	23.70	22.17	30.26	28.32	21.87
5000	0.47	23.15	23.03	35.85	34.14	19.90
5500	0.50	22.69	22.34	46.97	45.36	18.27
6000	0.54	22.33	21.57	26.99	27.07	18.67
6500	0.60	22.08	20.38	20.18	20.09	18.26
7000	0.68	21.86	19.57	17.09	17.11	19.10
7500	0.72	21.70	20.41	17.15	17.05	21.59
8000	0.71	21.57	22.03	19.31	19.21	18.92
8500	0.73	21.47	22.76	20.36	20.23	17.64
9000	0.81	21.50	21.77	17.64	17.32	16.82
9500	0.97	21.53	18.77	13.47	13.18	15.97
10000	1.13	21.64	16.57	11.32	11.12	17.40
10500	1.15	21.63	15.61	11.59	11.40	16.76
11000	1.01	21.47	15.41	14.81	14.72	18.51
11500	0.91	21.43	16.55	21.10	21.16	19.60
12000	0.91	21.52	18.46	25.84	26.60	17.69
12500	0.94	21.67	17.90	23.36	24.32	15.51
13000	0.97	21.76	17.14	22.92	23.87	16.59
13500	0.99	21.85	16.16	22.90	22.36	13.90
14000	1.01	21.92	15.88	24.58	22.98	14.31
14500	1.04	21.99	15.02	24.78	23.58	14.38
15000	1.07	21.85	14.15	25.46	25.33	16.93
15500	1.13	21.81	13.46	31.02	23.41	19.24
16000	1.26	21.79	13.63	17.55	16.75	18.58
16500	1.35	21.74	14.50	13.77	14.33	23.78
17000	1.30	21.79	15.94	15.75	16.73	16.46
17500	1.21	21.62	15.52	24.75	29.32	16.75
18000	1.24	21.51	12.63	23.68	23.64	14.79
18500	1.25	20.99	10.87	23.74	21.99	19.62
19000	1.28	20.73	10.23	28.56	21.49	5.05
19500	1.39	20.50	10.64	17.13	15.76	10.01
20000	1.49	20.32	11.75	14.12	13.03	9.16
21000	1.41	20.21	12.56	26.69	22.95	14.48
22000	1.55	20.11	10.69	17.69	16.30	14.93
23000	1.63	19.17	8.68	21.22	21.99	20.62
24000	1.83	18.65	9.07	15.03	14.90	22.37



P.O. Box 350166, Brooklyn, New York 11235-0003 (718) 934-4500 • Fax (718) 332-4661 For detailed performance specs & shopping online see Mini-Circuits web site



The Design Engineers Search Engine Provides ACTUAL Data Instantly From MINI-CIRCUITS At: www.minicircuits.com

IF/RF MICROWAVE COMPONENTS

REV. OR
EDC21-24+
1/22/2018
Page 3 of 3

Typical Performance Curves

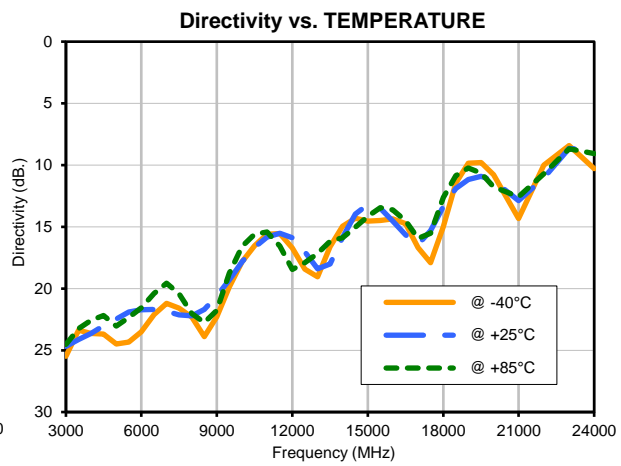
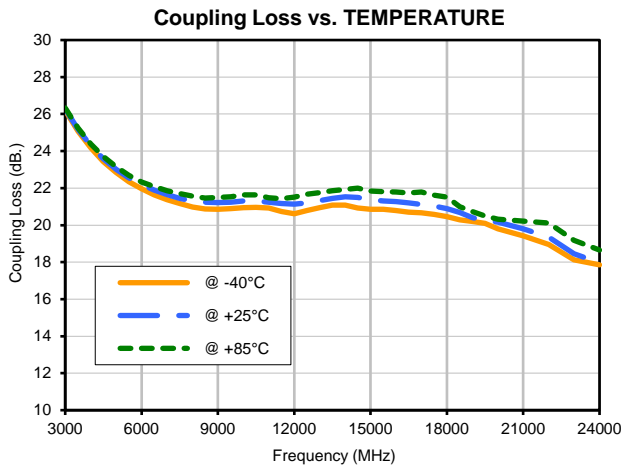
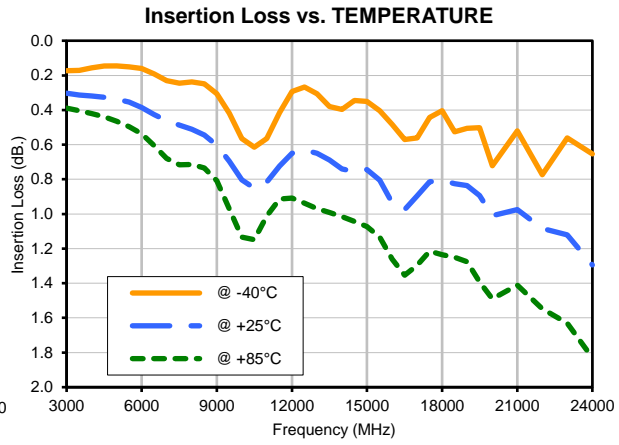
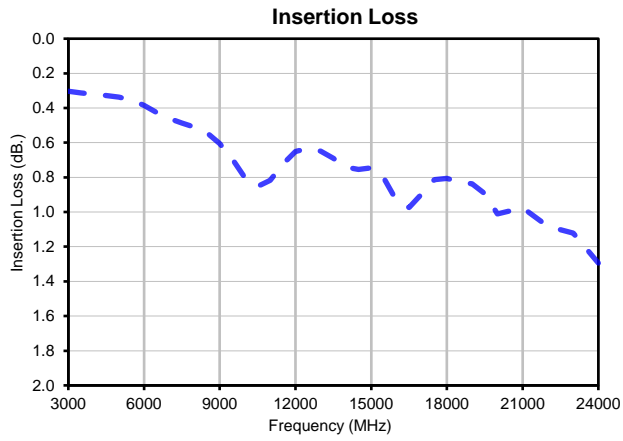

Typical Performance Curves

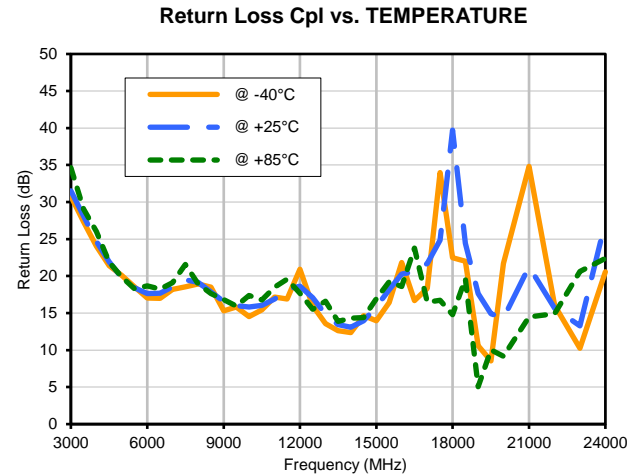
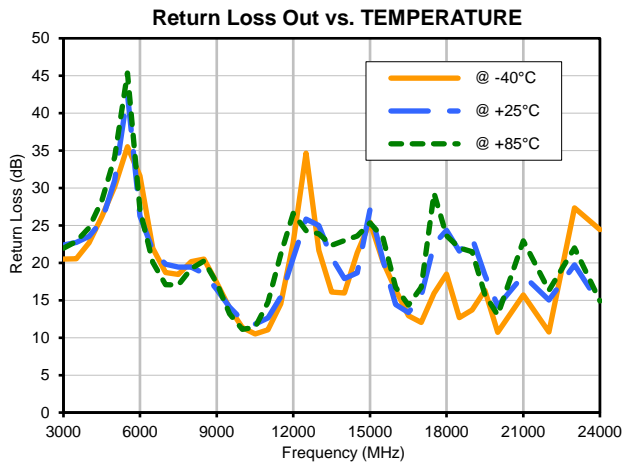
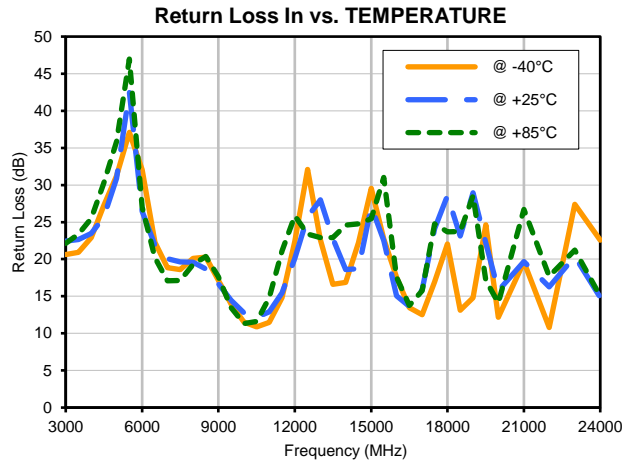
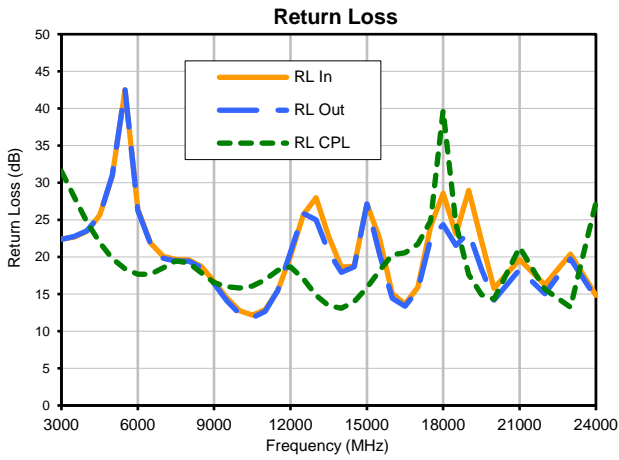

Outline Dimensions

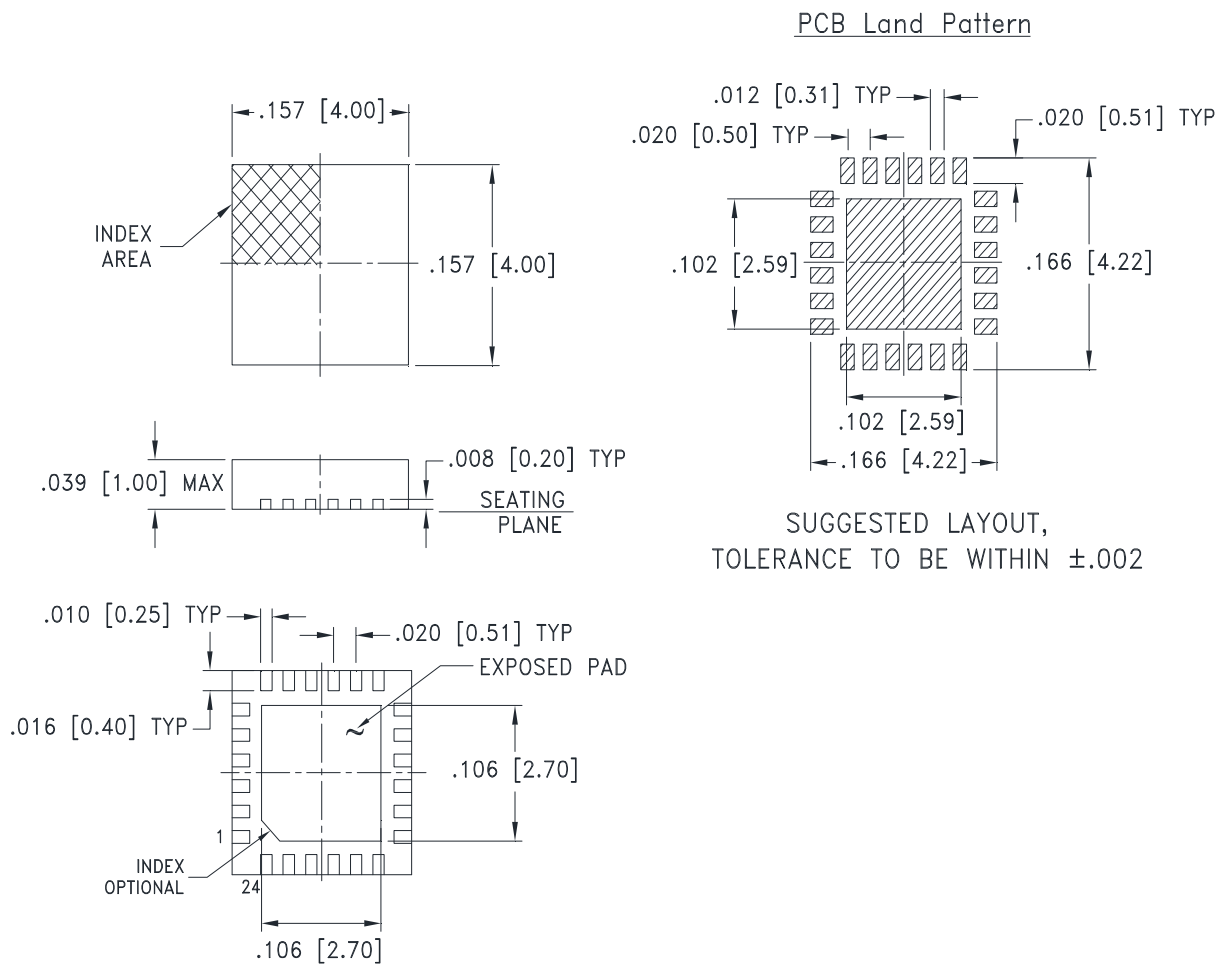

Weight: .04 Grams

Dimensions are in inches (mm). Tolerances: 2 Pl. $\pm .01$; 3 Pl. $\pm .005$

Notes:

- Case material: Plastic.
- Termination finish:
 - For RoHS Case Styles: Tin-Silver alloy plate over Nickel barrier or Matte-Tin. All models, (+) suffix. See model Data sheet.
 - For RoHS-5 Case Styles: Tin-Lead plate. All models, no (+) suffix.

Mini-Circuits®
ISO 9001 ISO 14001 CERTIFIED

ALL NEW
minicircuits.com

P.O. Box 350166, Brooklyn, New York 11235-0003 (718) 934-4500 Fax (718) 332-4661 For detailed performance specs & shopping online see Mini-Circuits web site



The Design Engineers Search Engine Provides ACTUAL Data Instantly From MINI-CIRCUITS At: www.minicircuits.com

RF/IF MICROWAVE COMPONENTS

DG1847 Rev.: AJ (27 FEB 26) ECO-028636 File: DG1847

This document and its contents are the property of Mini-Circuits.

Tape & Reel Packaging TR-F68

DEVICE ORIENTATION IN T&R

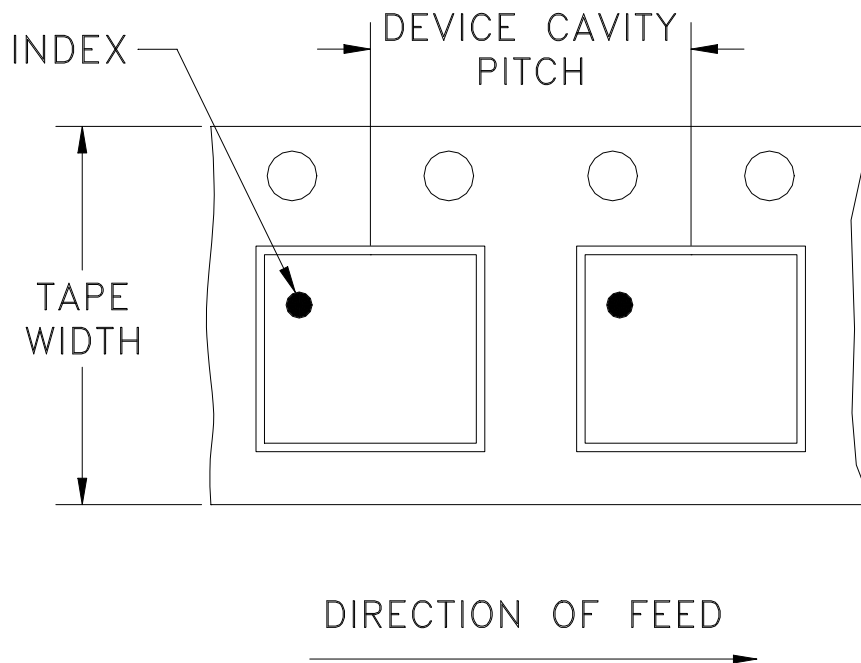

Tape Width, mm	Device Cavity Pitch, mm	Reel Size, inches	Devices per Reel see note	
12	8	7	Small quantity standard	20
				50
				100
				200
				500
		7	Standard	1000
		13	Standard	2000
				3000
4000				

Mini-Circuits carrier tape materials provide protection from ESD (Electro-Static Discharge) during handling and transportation. Tapes are static dissipative and comply with industry standards EIA-481/EIA-541.

Go to: www.minicircuits.com/pages/pdfs/tape.pdf



INTERNET <http://www.minicircuits.com>

P.O. Box 350166, Brooklyn, New York 11235-0003 (718) 934-4500 Fax (718) 332-4661

Distribution Centers NORTH AMERICA 800-654-7949 • 417-335-5935 • Fax 417-335-5945 • EUROPE 44-1252-832600 • Fax 44-1252-837010

Mini-Circuits ISO 9001 & ISO 14001 Certified

THIRD ANGLE PROJECTION

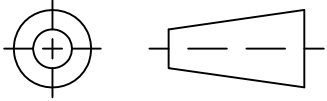

REVISIONS

REV	ECN No.	DESCRIPTION	DATE	DR	AUTH
OR	M164615	NEW RELEASE	11/10/17	ITG	SH

SUGGESTED MOUNTING CONFIGURATION
FOR DG1847 CASE STYLE, "24DC03" PIN CODE

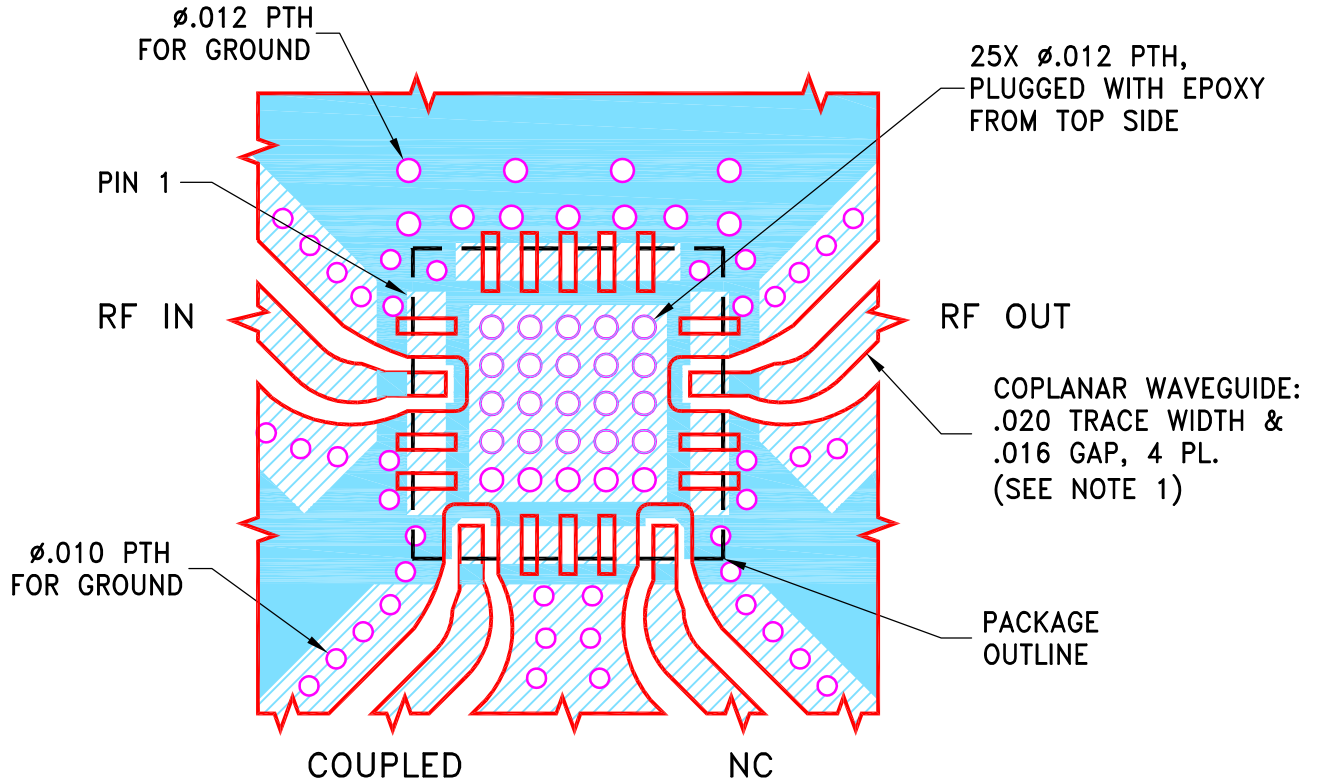

NOTES:

1. TRACE WIDTH & GAP PARAMETERS ARE SHOWN FOR ROGERS R04350B WITH DIELECTRIC THICKNESS .010"±.001". COPPER: 1/2 OZ. EACH SIDE. FOR OTHER MATERIALS TRACE WIDTH & GAP MAY NEED TO BE MODIFIED.
2. BOTTOM SIDE OF THE PCB IS CONTINUOUS GROUND PLANE.

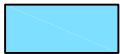

DENOTES PCB COPPER LAYOUT WITH SMOBC (SOLDER MASK OVER BARE COPPER).

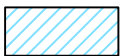

DENOTES COPPER LAND PATTERN FREE OF SOLDER MASK.

UNLESS OTHERWISE SPECIFIED	INITIALS	DATE
DRAWN	ITG	11/03/17
CHECKED	IL	11/10/17
APPROVED	SH	11/10/17



Mini-Circuits®

13 Neptune Avenue
Brooklyn NY 11235

PL, 24DC03, DG1847, TB-978+

Mini-Circuits®
THIS DOCUMENT AND ITS CONTENTS ARE THE PROPERTY OF MINI-CIRCUITS. EXCEPT FOR USE EXPRESSLY GRANTED, IN WRITING, TO ITS VENDORS, VENDEE AND THE UNITED STATES GOVERNMENT, MINI-CIRCUITS RESERVES ALL PROPRIETARY DESIGN, USE, MANUFACTURING AND REPRODUCTION RIGHTS THERETO. THESE CONTENTS SHALL NOT BE USED, DUPLICATED OR DISCLOSED TO ANY OUTSIDE PARTY, IN WHOLE OR IN PART, WITHOUT WRITTEN PERMISSION OF MINI-CIRCUITS.

ASHEETA1.DWG REV:A DATE:01/12/95

SIZE	CODE IDENT	DRAWING NO:	REV:
A	15542	98-PL-532	OR
FILE:	98PL532	SCALE: 10:1	SHEET: 1 OF 1

Evaluation Board and Circuit

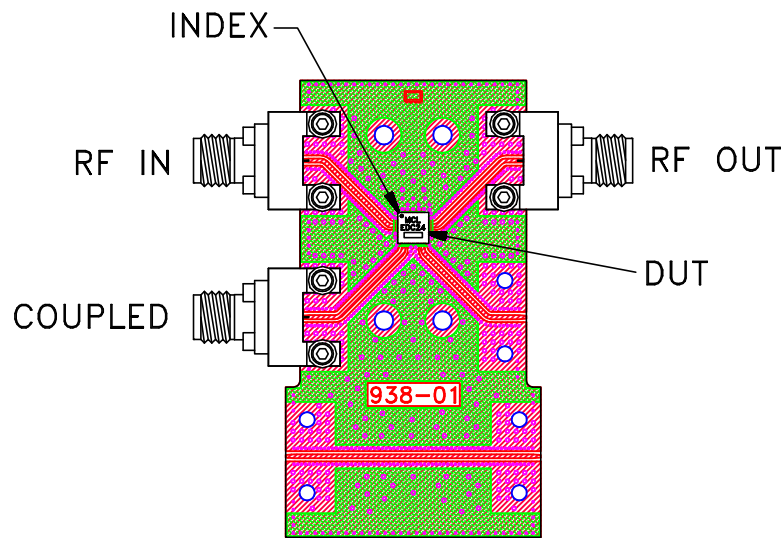

TB-978+

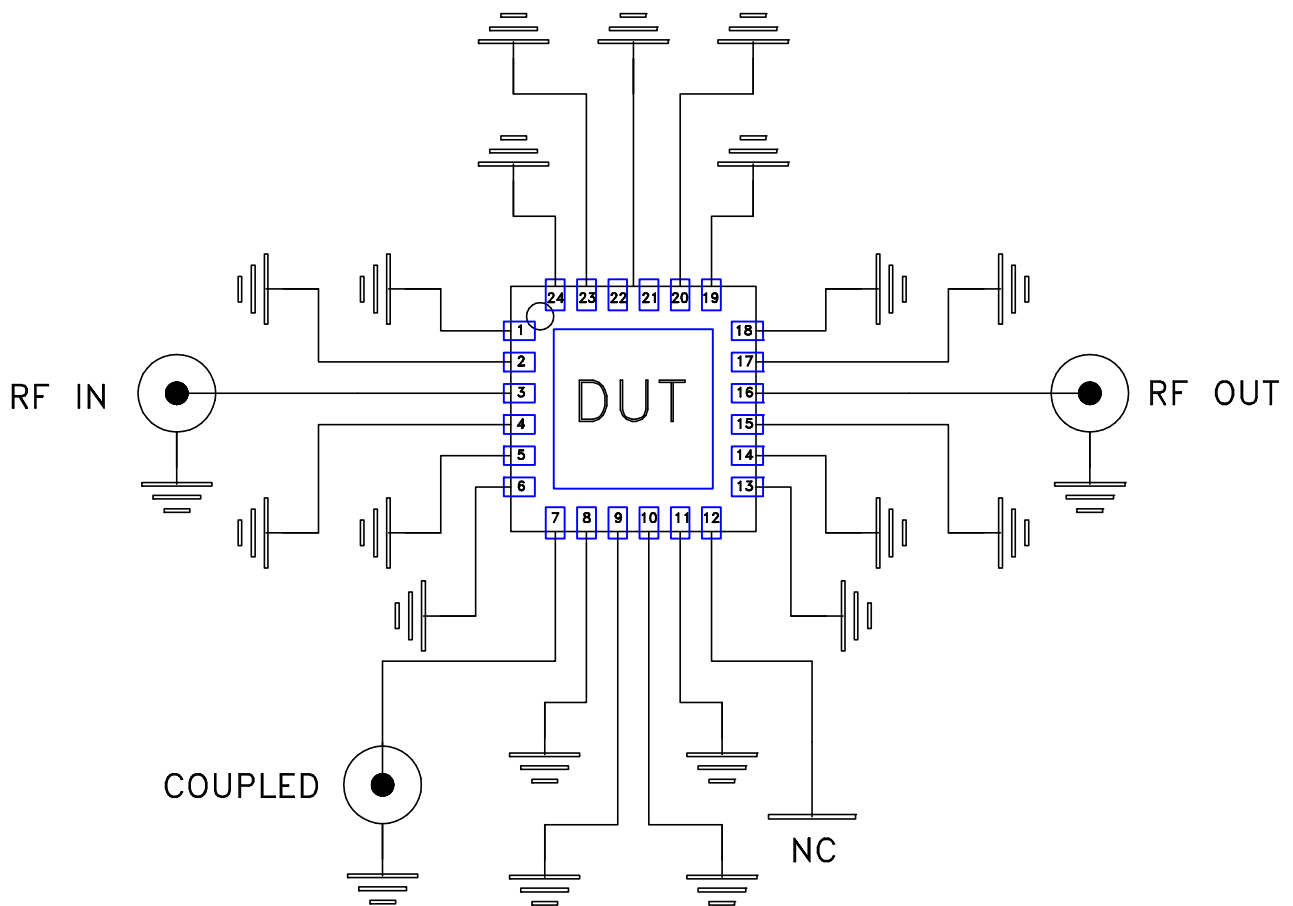

Schematic Diagram

Notes:

1. 50 Ohm 2.92mm Female end launch connectors.
2. PCB Material: R04350 or equivalent,
Dielectric Constant=3.5, Thickness=.010 inch.

 **Mini-Circuits®**

All Mini-Circuits products are manufactured under exacting quality assurance and control standards, and are capable of meeting published specifications after being subjected to any or all of the following physical and environmental test.

Specification	Test/Inspection Condition	Reference/Spec
Operating Temperature	-45° to 85°C or -40° to 85°C Ambient Environment	Individual Model Data Sheet
Storage Temperature	-65° to 150° C Ambient Environment	Individual Model Data Sheet
Thermal Shock	-55° to 100°C, 100 cycles	MIL-STD-202, Method 107, Condition A-3, except +100°C
Mechanical Shock	1.5Kg, 0.5 ms, 5 shock pulses, Y1 direction only	MIL-STD-883, Method 2002, Condition B, except Y1 direction only
Vibration (Variable Frequency)	50g peak	MIL-STD-883, Method 2007, Condition B
Autoclave	15 psig, 100% RH, 121°C, 96 hours	JESD22-A102, Condition C
HAST	130°C, 85% RH, 96 hours	JESD22-A110
Solderability	10X Magnification	J-STD-002, Para 4.2.5, Test S, 95% Coverage
Solder Reflow Heat	Sn-Pb Eutetic Process: 240°C peak Pb-Free Process: 260°C peak	J-STD-020, Table 4-1, 4-2 and 5-2; Figure 5-1
Moisture Sensitivity: Level 1	Bake at 125°C for 24 hours Soak at 85°C/85% RH for 168 hours, Reflow 3 cycles at 260°C peak	J-STD-020
Marking Resistance to Solvents	Isopropyl alcohol + mineral spirits at 25°C; terpene defluxer at 25°C; distilled water + proylene glycol monomethyl ether +	MIL-STD-202, Method 215



All Mini-Circuits products are manufactured under exacting quality assurance and control standards, and are capable of meeting published specifications after being subjected to any or all of the following physical and environmental test.

Specification	Test/Inspection Condition	Reference/Spec
	monoethanolamine at 63°C to 70°C	