



MMIC SURFACE MOUNT

Power Splitter/ Combiner

EP3-19+

Mini-Circuits

3 Way-0° 50Ω 15 to 25 GHz

THE BIG DEAL

- Wide Bandwidth, 15 to 25 GHz
- High Isolation, 22 dB typ at 19 GHz
- Low cost splitter for 5G Application
- Excellent amplitude unbalance, 0.1 dB typ. at 19 GHz
- Good phase unbalance, 1.2° typ. at 19 GHz
- Small size, 3.5x2.5 mm
- Aqueous washable

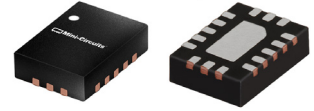

Generic photo used for illustration purposes only

CASE STYLE: JV2579

+RoHS Compliant

The +Suffix identifies RoHS Compliance. See our web site for RoHS Compliance methodologies and qualifications

APPLICATIONS

- 5G
- Phased Array Radar
- Instrumentation
- MIMO
- Satellite communications

PRODUCT OVERVIEW

Mini-Circuits' EP3-19+ is a MMIC 3-way 0° splitter/combiner designed for wideband operation from 15 to 25 GHz supporting many applications requiring high performance across a wide frequency range including phased array radars, 5G applications, as well as instrumentation and more. This model provides excellent power handling up to 0.5 W / 0.63 W (as a splitter/combiner) with good isolation, and low phase and amplitude unbalance in a tiny 3.5x 2.5 mm 16 lead-QFN package. Manufactured using GaAs IPD technology, the EP3-19+ not only provides a repeatable performance, but also a high level of ESD protection.

KEY FEATURES

Feature	Advantages
Wideband, 15 to 25 GHz	Low cost power splitter designed for phased array radars and 5G applications
Excellent power handling, 0.5 W as a splitter 0.63 W as a combiner	In power combiner applications, half the power is dissipated internally. EP3-19+ is designed to handle 0.63 W internal dissipation as a combiner allowing reliable operation without excessive temperature rise
Excellent Amplitude unbalance, 0.1 dB typ. at 19 GHz Good phase unbalance, 1.2° typ. at 19 GHz	Ideal for Applications such as MIMO & phased array radars
Tiny size, 3.5X2.5 mm QFN package	Tiny footprint saves space in dense layouts while providing low inductance, repeatable transitions, and excellent thermal contact to the PCB

REV. OR
ECO-012360
EP3-19+
MCL NY
220317





ELECTRICAL SPECIFICATIONS¹ AT 25°C

Parameter	Frequency (GHz)	Min.	Typ.	Max.	Unit
Frequency Range		15		25	GHz
Insertion Loss (above 4.8 dB)	17.55 - 20.45	—	0.3	1.3	dB
	15 - 25	—	0.5	2.1	
Isolation	17.55 - 20.45	17	23	—	dB
	15 - 25	12	27	—	
Amplitude Unbalance	17.55 - 20.45	—	0.1	0.6	dB
	15 - 25	—	0.3	1.1	
Phase Unbalance	17.55 - 20.45	—	1	7	Degree
	15 - 25	—	1	8	
VSWR (Port S)	17.55 - 20.45	—	1.2	—	:1
	15 - 25	—	1.2	—	
VSWR (Port 1-2-3)	17.55 - 20.45	—	1.2	—	:1
	15 - 25	—	1.2	—	
Power Handling	As a splitter	15 - 25	—	0.5	W
	As a combiner ²	15 - 25	—	0.63	

1. Tested on Mini-Circuits Test Board TB-EP3-19C+

2. As a combiner of non-coherent signals, max. power per port is 0.21 watt.

MAXIMUM RATINGS

Parameter	Ratings
Operating temperature	-55°C to 105°C
Storage temperature	-65°C to 150°C

Permanent damage may occur if any of these limits are exceeded.

PAD CONNECTIONS

Function	Pad Number
SUM	15
PORT 1	10
PORT 2	7
PORT 3	4
GROUND	3,5,6,8,9,11,14,16, PADDLE
NOT USED	1,2,12,13

SIMPLIFIED SCHEMATIC

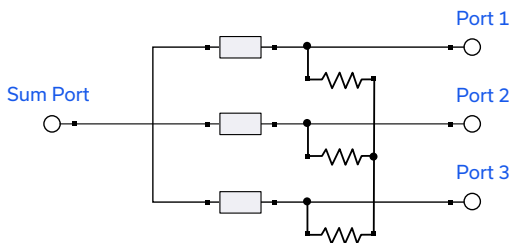

PRODUCT MARKING

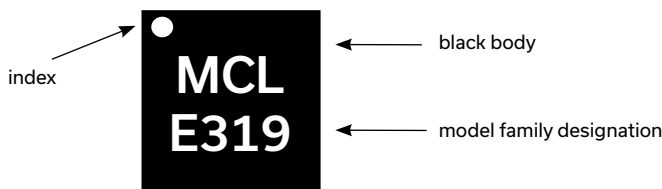

Marking may contain other features or characters for internal lot control



ADDITIONAL DETAILED TECHNICAL INFORMATION IS AVAILABLE ON OUR DASH BOARD. TO ACCESS [CLICK HERE](#)

Performance Data	Data Table Swept Graphs S-Parameter (S3P Files) Data Set (.zip file)
Case Style	JV2579 Plastic package, exposed paddle lead finish: matte-tin
Tape & Reel Standard quantities available on reel	F104 7" reels with 20, 50, 100, 200, 500 ,1000 and 2000 devices
Suggested Layout for PCB Design	PL-728
Evaluation Board	TB-EP3-19+ (without connectors) TB-EP3-19C+ (with connectors)
Environmental Ratings	ENV82

ESD RATING

Human Body Model (HBM): Class 1C (Pass 1000V) in accordance with ANSI/ESD STM 5.1 - 2001

MSL TEST FLOW CHART

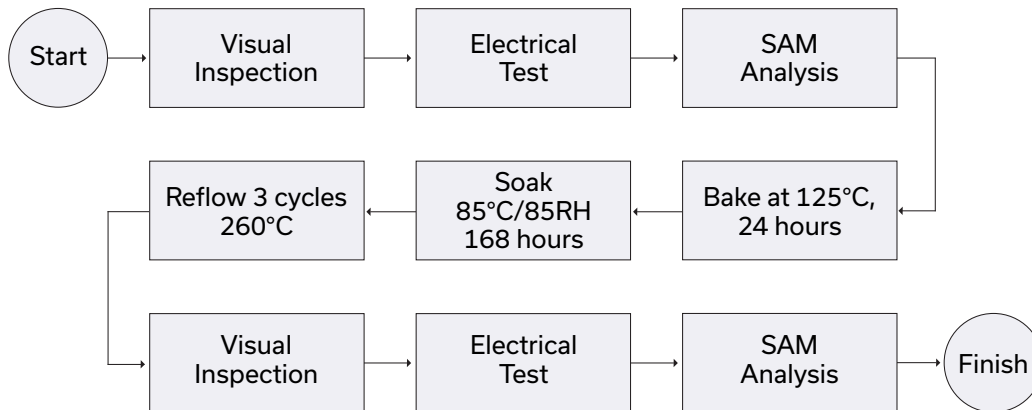

- NOTES**
- A. Performance and quality attributes and conditions not expressly stated in this specification document are intended to be excluded and do not form a part of this specification document.
 - B. Electrical specifications and performance data contained in this specification document are based on Mini-Circuit's applicable established test performance criteria and measurement instructions.
 - C. The parts covered by this specification document are subject to Mini-Circuits standard limited warranty and terms and conditions (collectively, "Standard Terms"); Purchasers of this part are entitled to the rights and benefits contained therein. For a full statement of the standard terms and the exclusive rights and remedies thereunder, please visit Mini-Circuits' website at www.minicircuits.com/MCLStore/terms.jsp

3 Way-0° Power Splitter/Combiner

EP3-19+

Typical Performance Data

TEST CONDITIONS: Input Power = 0dBm @Temperature = +25°C

FREQ.	TOTAL LOSS ⁽¹⁾			AMP. UNBAL.	PHASE UNBAL.	ISOLATION			VSWR			
	(MHz)	(dB) S-1	(dB) S-2			(dB) S-3	(dB)	(deg.)	(dB) 1-2	(dB) 1-3	(dB) 2-3	(:1)
15000	5.08	5.28	5.10	0.20	1.23	23.94	18.49	23.24	1.25	1.05	1.08	1.03
15200	5.08	5.26	5.09	0.19	1.26	24.87	18.91	24.07	1.21	1.08	1.09	1.04
15400	5.08	5.25	5.08	0.17	1.29	25.62	19.20	24.73	1.20	1.09	1.10	1.05
15600	5.08	5.23	5.07	0.16	1.26	26.46	19.51	25.46	1.19	1.11	1.10	1.06
15800	5.08	5.22	5.07	0.15	1.26	27.32	19.81	26.20	1.18	1.11	1.12	1.06
16000	5.08	5.21	5.07	0.14	1.25	28.22	20.09	26.96	1.17	1.12	1.11	1.07
16200	5.08	5.19	5.06	0.13	1.23	29.25	20.39	27.82	1.16	1.12	1.12	1.07
16400	5.09	5.18	5.07	0.11	1.16	30.32	20.67	28.69	1.15	1.12	1.12	1.07
16600	5.08	5.17	5.07	0.10	1.16	31.75	21.03	29.85	1.14	1.11	1.13	1.08
16800	5.08	5.15	5.07	0.08	1.12	33.36	21.38	31.10	1.12	1.10	1.12	1.09
17000	5.09	5.15	5.08	0.07	1.14	35.37	21.74	32.57	1.11	1.10	1.14	1.10
17200	5.09	5.13	5.08	0.05	1.14	37.85	22.10	34.26	1.10	1.10	1.14	1.12
17400	5.09	5.12	5.09	0.04	1.16	41.19	22.45	36.26	1.09	1.10	1.16	1.13
17600	5.09	5.11	5.10	0.02	1.18	45.70	22.75	38.50	1.10	1.11	1.17	1.15
17800	5.10	5.10	5.10	0.01	1.24	51.79	22.95	40.67	1.11	1.13	1.19	1.16
18000	5.10	5.09	5.11	0.01	1.29	56.43	23.17	43.67	1.13	1.15	1.21	1.18
18200	5.10	5.08	5.11	0.03	1.30	51.04	23.28	46.45	1.15	1.17	1.22	1.20
18400	5.10	5.06	5.10	0.05	1.36	47.45	23.30	47.33	1.16	1.20	1.22	1.21
18600	5.10	5.03	5.10	0.07	1.38	43.72	23.43	47.91	1.16	1.22	1.21	1.22
18800	5.09	5.01	5.10	0.08	1.37	40.71	23.51	43.90	1.14	1.21	1.21	1.23
19000	5.10	4.99	5.09	0.11	1.48	37.41	23.72	39.72	1.12	1.24	1.19	1.22
19200	5.11	4.97	5.10	0.14	1.46	34.64	24.04	36.50	1.10	1.24	1.15	1.22
19400	5.12	4.97	5.10	0.16	1.47	32.17	24.40	33.60	1.09	1.22	1.12	1.21
19600	5.16	4.98	5.13	0.18	1.46	29.89	25.02	31.09	1.11	1.24	1.11	1.21
19800	5.20	5.00	5.16	0.20	1.43	28.17	25.75	29.29	1.15	1.22	1.09	1.20
20000	5.24	5.02	5.20	0.23	1.42	26.46	26.85	27.47	1.20	1.23	1.07	1.20
20200	5.28	5.04	5.24	0.24	1.38	25.14	28.14	26.11	1.24	1.22	1.06	1.19
20400	5.32	5.06	5.27	0.26	1.36	24.02	29.79	24.94	1.27	1.21	1.06	1.17
20600	5.34	5.06	5.29	0.28	1.32	23.04	32.03	23.94	1.31	1.22	1.05	1.16
20800	5.34	5.05	5.29	0.30	1.27	22.28	35.13	23.16	1.31	1.22	1.03	1.13
21000	5.33	5.02	5.29	0.31	1.26	21.68	39.25	22.57	1.31	1.17	1.03	1.10
21200	5.32	5.00	5.28	0.32	1.24	21.20	46.90	22.10	1.32	1.17	1.06	1.07
21400	5.31	4.97	5.28	0.34	1.18	20.94	49.15	21.85	1.31	1.15	1.08	1.06
21600	5.31	4.96	5.28	0.36	1.17	20.68	42.19	21.61	1.33	1.14	1.12	1.08
21800	5.32	4.95	5.30	0.38	1.18	20.59	37.96	21.55	1.34	1.14	1.15	1.11
22000	5.34	4.95	5.32	0.40	1.17	20.64	35.96	21.64	1.34	1.15	1.18	1.15
22200	5.37	4.95	5.36	0.42	1.15	20.69	34.69	21.74	1.36	1.15	1.20	1.19
22400	5.40	4.96	5.39	0.44	1.17	20.88	34.13	21.97	1.35	1.17	1.21	1.22
22600	5.44	4.98	5.44	0.46	1.19	20.96	34.31	22.08	1.35	1.18	1.23	1.25
22800	5.48	4.99	5.48	0.49	1.24	21.02	34.75	22.15	1.35	1.20	1.23	1.28
23000	5.51	5.00	5.51	0.52	1.24	20.99	36.02	22.11	1.33	1.21	1.22	1.29
23200	5.55	5.01	5.55	0.55	1.27	20.80	37.78	21.89	1.32	1.23	1.21	1.31
23400	5.59	5.02	5.59	0.58	1.30	20.46	41.24	21.48	1.32	1.22	1.18	1.33
23600	5.64	5.05	5.65	0.60	1.31	19.93	48.03	20.87	1.35	1.25	1.18	1.34
23800	5.70	5.08	5.70	0.62	1.36	19.37	47.58	20.23	1.40	1.27	1.16	1.35
24000	5.77	5.12	5.77	0.65	1.41	18.71	40.53	19.51	1.46	1.27	1.16	1.37
24200	5.85	5.18	5.85	0.67	1.46	18.08	36.12	18.83	1.54	1.27	1.18	1.38
24400	5.93	5.24	5.93	0.69	1.55	17.47	33.20	18.19	1.62	1.27	1.18	1.39
24600	6.02	5.30	6.01	0.72	1.53	16.98	31.25	17.66	1.68	1.31	1.20	1.41
24800	6.10	5.36	6.09	0.74	1.51	16.50	29.54	17.15	1.75	1.32	1.22	1.40
25000	6.17	5.41	6.16	0.76	1.58	16.10	28.29	16.73	1.80	1.33	1.21	1.41

⁽¹⁾ Total Loss = Insertion Loss + 4.8dB Splitter Loss

3 Way-0° Power Splitter/Combiner

EP3-19+

Typical Performance Data

TEST CONDITIONS: Input Power = 0dBm @Temperature = -55°C

FREQ.	TOTAL LOSS ⁽¹⁾			AMP. UNBAL.	PHASE UNBAL.	ISOLATION			VSWR			
	(MHz)	(dB) S-1	(dB) S-2			(dB) S-3	(dB) 1-2	(dB) 1-3	(dB) 2-3	(:1)		
15000	4.93	5.19	4.94	0.26	2.95	23.07	17.93	22.43	1.30	1.01	1.04	1.06
15200	4.92	5.17	4.93	0.25	3.04	24.01	18.38	23.29	1.27	1.04	1.05	1.06
15400	4.93	5.16	4.93	0.23	3.12	24.86	18.74	24.04	1.25	1.05	1.06	1.05
15600	4.93	5.14	4.92	0.22	3.13	25.78	19.12	24.85	1.23	1.07	1.08	1.04
15800	4.93	5.13	4.91	0.22	3.16	26.89	19.54	25.82	1.20	1.09	1.10	1.03
16000	4.93	5.12	4.91	0.21	3.18	27.93	19.89	26.70	1.19	1.11	1.10	1.04
16200	4.94	5.11	4.90	0.20	3.16	28.96	20.19	27.55	1.18	1.14	1.12	1.07
16400	4.94	5.09	4.90	0.19	3.09	29.88	20.43	28.31	1.17	1.14	1.12	1.08
16600	4.93	5.07	4.90	0.17	3.08	31.03	20.71	29.23	1.16	1.13	1.13	1.10
16800	4.92	5.06	4.90	0.16	3.06	32.19	20.96	30.15	1.14	1.12	1.12	1.11
17000	4.92	5.04	4.90	0.14	3.08	33.68	21.26	31.30	1.12	1.11	1.13	1.12
17200	4.91	5.02	4.90	0.12	3.12	35.67	21.62	32.76	1.10	1.10	1.13	1.12
17400	4.91	5.01	4.90	0.11	3.18	38.12	21.98	34.46	1.08	1.08	1.14	1.11
17600	4.91	5.00	4.91	0.09	3.25	41.47	22.41	36.73	1.07	1.07	1.15	1.11
17800	4.92	4.99	4.91	0.07	3.33	45.37	22.81	39.50	1.08	1.10	1.18	1.12
18000	4.93	4.98	4.92	0.06	3.41	47.07	23.25	44.29	1.11	1.14	1.21	1.15
18200	4.93	4.97	4.92	0.05	3.41	45.12	23.48	52.47	1.17	1.19	1.24	1.19
18400	4.94	4.95	4.92	0.03	3.45	43.71	23.47	59.74	1.21	1.24	1.27	1.23
18600	4.94	4.93	4.92	0.02	3.46	42.76	23.39	58.41	1.24	1.28	1.28	1.26
18800	4.91	4.89	4.90	0.02	3.41	44.48	23.13	54.21	1.24	1.28	1.29	1.29
19000	4.89	4.84	4.87	0.05	3.53	43.37	23.04	46.50	1.21	1.32	1.27	1.30
19200	4.87	4.80	4.85	0.07	3.55	39.89	23.00	40.92	1.15	1.31	1.22	1.30
19400	4.86	4.78	4.84	0.08	3.55	35.37	23.00	35.74	1.08	1.27	1.18	1.28
19600	4.89	4.79	4.87	0.10	3.61	31.37	23.40	31.91	1.08	1.26	1.16	1.28
19800	4.96	4.83	4.92	0.13	3.66	28.70	24.07	29.36	1.16	1.24	1.13	1.26
20000	5.03	4.88	4.99	0.15	3.69	26.47	25.16	27.20	1.25	1.24	1.11	1.25
20200	5.10	4.93	5.06	0.17	3.69	24.88	26.50	25.64	1.31	1.22	1.12	1.24
20400	5.14	4.95	5.10	0.19	3.72	23.53	28.23	24.30	1.36	1.20	1.12	1.20
20600	5.16	4.95	5.10	0.21	3.68	22.44	30.91	23.22	1.38	1.21	1.11	1.16
20800	5.13	4.91	5.08	0.22	3.67	21.74	34.80	22.55	1.35	1.18	1.07	1.10
21000	5.10	4.87	5.05	0.23	3.73	21.33	40.27	22.18	1.32	1.14	1.06	1.07
21200	5.08	4.83	5.03	0.25	3.76	21.08	48.06	21.97	1.31	1.14	1.09	1.05
21400	5.08	4.81	5.03	0.27	3.79	20.99	45.64	21.91	1.30	1.15	1.10	1.08
21600	5.09	4.81	5.04	0.28	3.76	20.87	41.21	21.80	1.32	1.18	1.14	1.12
21800	5.11	4.81	5.07	0.30	3.74	20.83	38.21	21.80	1.33	1.17	1.16	1.14
22000	5.14	4.81	5.09	0.33	3.80	20.85	36.75	21.85	1.33	1.19	1.16	1.15
22200	5.16	4.81	5.12	0.35	3.77	20.83	35.95	21.85	1.34	1.17	1.16	1.17
22400	5.18	4.81	5.15	0.38	3.78	20.82	35.80	21.87	1.33	1.16	1.16	1.19
22600	5.21	4.82	5.19	0.39	3.81	20.69	36.03	21.74	1.34	1.15	1.18	1.22
22800	5.25	4.83	5.23	0.42	3.88	20.57	36.03	21.62	1.37	1.18	1.20	1.25
23000	5.30	4.85	5.27	0.45	3.86	20.54	36.04	21.60	1.39	1.21	1.21	1.28
23200	5.33	4.85	5.32	0.48	3.91	20.62	36.13	21.69	1.39	1.24	1.20	1.31
23400	5.36	4.86	5.35	0.50	3.95	20.54	38.09	21.59	1.36	1.22	1.18	1.34
23600	5.41	4.88	5.40	0.52	4.02	20.21	41.30	21.22	1.38	1.24	1.17	1.36
23800	5.46	4.90	5.44	0.55	4.07	19.82	45.17	20.74	1.39	1.28	1.14	1.37
24000	5.52	4.94	5.50	0.57	4.15	19.18	43.71	20.02	1.45	1.27	1.14	1.38
24200	5.60	5.00	5.58	0.60	4.24	18.41	37.74	19.16	1.55	1.28	1.15	1.39
24400	5.67	5.05	5.66	0.62	4.34	17.65	34.06	18.35	1.64	1.26	1.15	1.39
24600	5.77	5.12	5.74	0.65	4.36	17.05	31.70	17.70	1.71	1.30	1.17	1.39
24800	5.84	5.17	5.81	0.67	4.34	16.52	29.86	17.14	1.78	1.31	1.19	1.37
25000	5.90	5.21	5.86	0.69	4.35	16.12	28.64	16.74	1.81	1.32	1.18	1.38

⁽¹⁾ Total Loss = Insertion Loss + 4.8dB Splitter Loss

3 Way-0° Power Splitter/Combiner

EP3-19+

Typical Performance Data

TEST CONDITIONS: Input Power = 0dBm @Temperature = +105°C

FREQ.	TOTAL LOSS ⁽¹⁾			AMP. UNBAL.	PHASE UNBAL.	ISOLATION			VSWR			
	(MHz)	(dB) S-1	(dB) S-2			(dB) S-3	(dB) 1-2	(dB) 1-3	(dB) 2-3	(:1)		
15000	5.17	5.37	5.19	0.20	1.50	24.87	18.99	24.10	1.20	1.07	1.09	1.03
15200	5.17	5.36	5.18	0.18	1.53	25.90	19.43	25.01	1.17	1.11	1.10	1.05
15400	5.17	5.34	5.18	0.17	1.56	26.73	19.73	25.72	1.16	1.12	1.12	1.06
15600	5.18	5.33	5.17	0.16	1.53	27.63	20.05	26.49	1.15	1.14	1.14	1.08
15800	5.18	5.32	5.17	0.15	1.52	28.47	20.31	27.20	1.15	1.15	1.15	1.09
16000	5.18	5.31	5.17	0.14	1.50	29.25	20.51	27.84	1.16	1.17	1.15	1.10
16200	5.19	5.30	5.17	0.12	1.48	30.11	20.72	28.55	1.16	1.17	1.16	1.11
16400	5.19	5.28	5.18	0.11	1.41	30.99	20.91	29.25	1.16	1.16	1.15	1.11
16600	5.19	5.27	5.18	0.09	1.41	32.21	21.18	30.21	1.15	1.14	1.14	1.12
16800	5.19	5.26	5.19	0.07	1.39	33.62	21.45	31.28	1.13	1.12	1.13	1.12
17000	5.19	5.25	5.19	0.06	1.42	35.51	21.78	32.66	1.11	1.11	1.13	1.12
17200	5.19	5.24	5.20	0.05	1.43	37.90	22.13	34.27	1.09	1.10	1.13	1.12
17400	5.19	5.23	5.21	0.04	1.46	41.05	22.46	36.16	1.08	1.09	1.15	1.13
17600	5.20	5.22	5.22	0.03	1.51	45.55	22.80	38.46	1.08	1.10	1.16	1.14
17800	5.20	5.21	5.22	0.02	1.56	50.93	23.05	40.80	1.09	1.12	1.18	1.15
18000	5.20	5.20	5.23	0.03	1.62	51.85	23.31	44.00	1.11	1.14	1.20	1.17
18200	5.21	5.19	5.23	0.04	1.64	48.16	23.44	46.72	1.14	1.17	1.21	1.19
18400	5.20	5.16	5.22	0.06	1.71	44.61	23.51	46.48	1.14	1.19	1.22	1.20
18600	5.21	5.14	5.23	0.08	1.74	41.48	23.67	45.12	1.15	1.21	1.21	1.21
18800	5.21	5.12	5.22	0.10	1.73	38.42	23.80	40.99	1.12	1.21	1.20	1.22
19000	5.22	5.11	5.22	0.12	1.84	35.33	24.12	37.31	1.10	1.23	1.18	1.21
19200	5.24	5.10	5.24	0.14	1.83	32.89	24.54	34.54	1.09	1.22	1.13	1.21
19400	5.26	5.10	5.25	0.16	1.86	30.60	25.06	31.95	1.10	1.20	1.11	1.20
19600	5.31	5.12	5.29	0.18	1.86	28.56	25.88	29.74	1.14	1.22	1.10	1.20
19800	5.34	5.14	5.32	0.21	1.86	27.03	26.84	28.13	1.18	1.20	1.07	1.18
20000	5.39	5.16	5.36	0.23	1.85	25.54	28.30	26.57	1.23	1.21	1.05	1.18
20200	5.42	5.17	5.39	0.25	1.81	24.46	29.96	25.45	1.26	1.20	1.04	1.16
20400	5.45	5.18	5.41	0.27	1.79	23.53	32.05	24.50	1.28	1.19	1.04	1.14
20600	5.46	5.17	5.42	0.28	1.74	22.73	35.01	23.67	1.31	1.21	1.02	1.12
20800	5.47	5.16	5.42	0.30	1.69	22.16	39.08	23.10	1.31	1.22	1.03	1.10
21000	5.46	5.14	5.42	0.32	1.69	21.75	43.33	22.70	1.30	1.18	1.04	1.08
21200	5.45	5.12	5.43	0.33	1.67	21.43	44.53	22.39	1.31	1.19	1.08	1.08
21400	5.45	5.10	5.43	0.35	1.62	21.27	41.29	22.26	1.30	1.17	1.09	1.09
21600	5.46	5.10	5.44	0.36	1.61	21.08	38.66	22.08	1.32	1.17	1.13	1.12
21800	5.48	5.10	5.47	0.38	1.62	21.04	36.45	22.09	1.32	1.17	1.16	1.15
22000	5.50	5.10	5.50	0.40	1.63	21.10	35.38	22.18	1.33	1.17	1.18	1.17
22200	5.53	5.10	5.53	0.43	1.61	21.16	34.69	22.28	1.33	1.17	1.19	1.20
22400	5.56	5.11	5.57	0.46	1.65	21.30	34.68	22.45	1.32	1.18	1.20	1.23
22600	5.59	5.13	5.61	0.48	1.68	21.28	35.37	22.44	1.31	1.18	1.21	1.26
22800	5.63	5.14	5.65	0.51	1.76	21.20	36.38	22.35	1.31	1.20	1.21	1.28
23000	5.67	5.16	5.70	0.54	1.76	21.01	38.34	22.12	1.29	1.21	1.20	1.30
23200	5.71	5.17	5.74	0.58	1.82	20.69	41.11	21.75	1.29	1.23	1.20	1.32
23400	5.76	5.19	5.80	0.61	1.90	20.16	46.41	21.13	1.31	1.21	1.17	1.34
23600	5.83	5.23	5.86	0.63	1.93	19.51	46.58	20.41	1.37	1.24	1.17	1.36
23800	5.90	5.27	5.93	0.65	2.02	18.87	40.02	19.70	1.43	1.26	1.16	1.37
24000	5.98	5.33	6.01	0.68	2.11	18.20	35.86	18.98	1.51	1.26	1.17	1.38
24200	6.06	5.39	6.10	0.70	2.21	17.58	32.94	18.32	1.60	1.26	1.19	1.39
24400	6.14	5.44	6.16	0.72	2.31	17.04	30.91	17.75	1.66	1.25	1.18	1.38
24600	6.22	5.50	6.23	0.74	2.32	16.62	29.54	17.32	1.71	1.29	1.19	1.38
24800	6.28	5.54	6.29	0.75	2.34	16.25	28.33	16.92	1.75	1.29	1.20	1.36
25000	6.34	5.57	6.34	0.77	2.42	15.95	27.48	16.61	1.77	1.31	1.18	1.35

⁽¹⁾ Total Loss = Insertion Loss + 4.8dB Splitter Loss

Typical Performance Curves

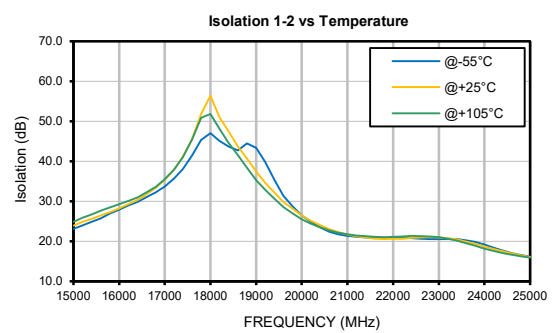
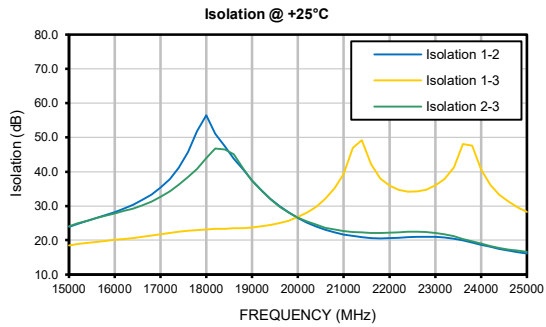
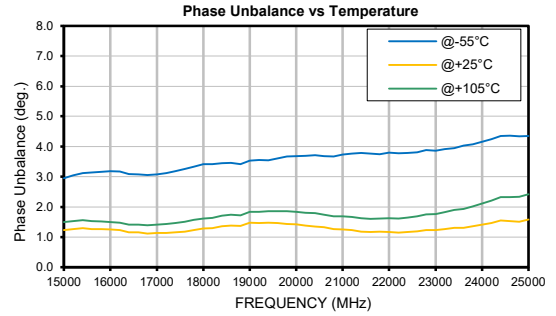
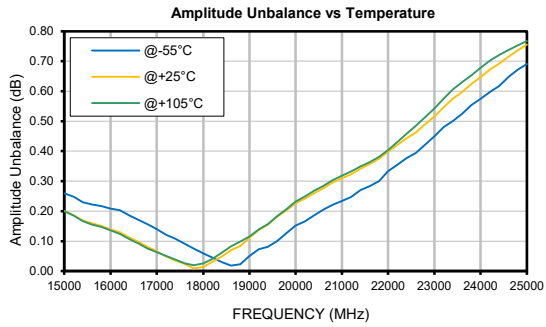
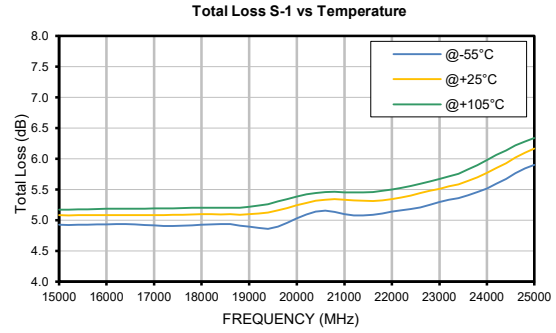
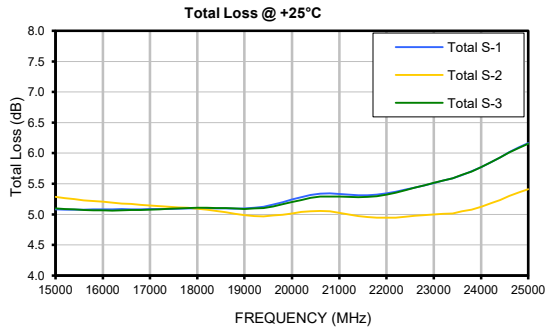

Typical Performance Curves

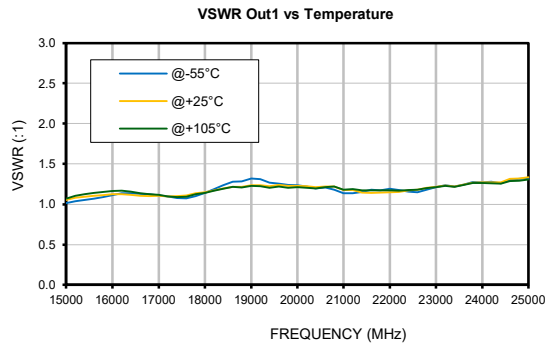
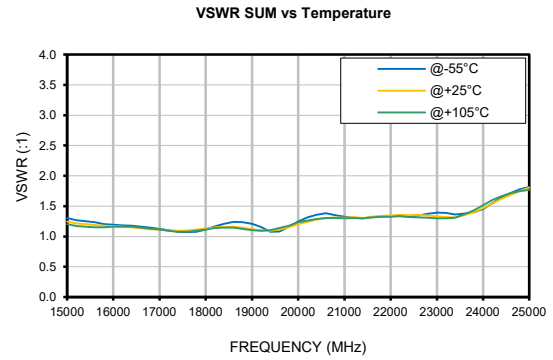
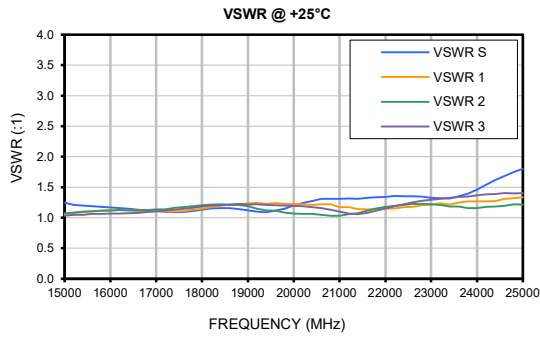

Outline Dimensions

JV2579

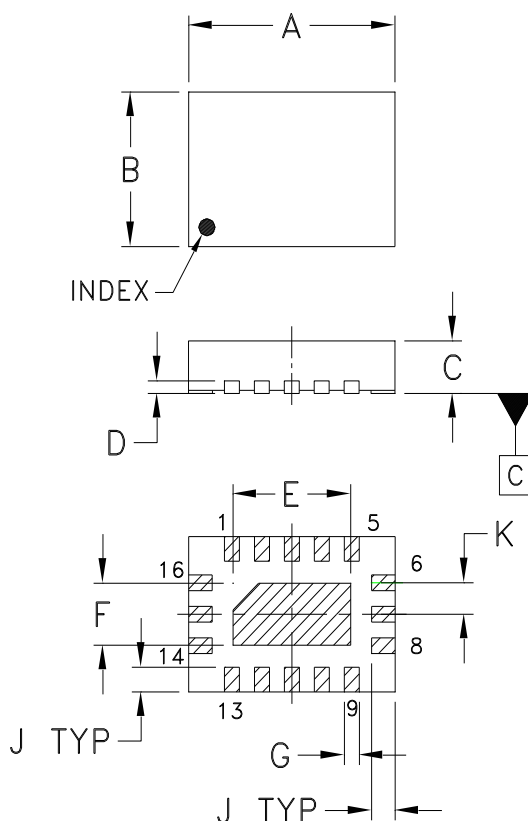

PCB Land Pattern

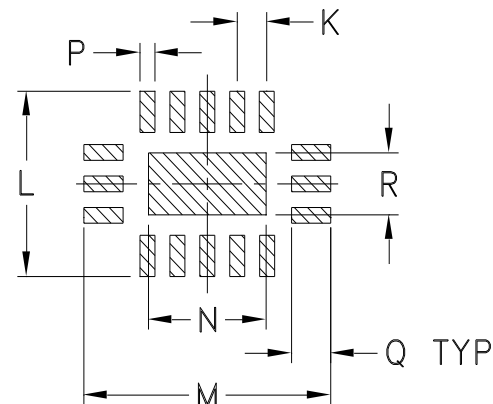

Suggested Layout,
Tolerance to be within ± 0.002

CASE #	A	B	C	D	E	F	G	H	J	K	L	M	N
JV2579	.138 (3.5)	.098 (2.5)	.033 (0.85)	.008 (0.20)	.079 (2.01)	.039 (0.99)	.010 (0.25)	-	.016 (0.41)	.020 (.51)	.118 (3.00)	.165 (4.19)	.079 (2.01)

CASE #	P	Q	R	WT. GRAM
JV2579	.010 (0.25)	.026 (0.66)	.039 (0.99)	.03

Dimensions are in inches (mm). Tolerances: 2 Pl. $\pm .01$; 3 Pl. $\pm .005$

Notes:

1. Case material: Plastic.
2. Termination finish: **as shown below or indicated on Data Sheet.**
For RoHS Case Styles: Matte-Tin plate.



P.O. Box 350166, Brooklyn, New York 11235-0003 (718) 934-4500 Fax (718) 332-4661 For detailed performance specs & shopping online see Mini-Circuits web site



The Design Engineers Search Engine Provides ACTUAL Data Instantly From MINI-CIRCUITS At: www.minicircuits.com

RF/IF MICROWAVE COMPONENTS

Tape & Reel Packaging TR-F104



Tape Width, mm	Device Cavity Pitch, mm	Reel Size, inches	Devices per Reel	
8	4	7	Small quantity standards (see note)	20
				50
				100
				200
				500
				1000
		7	Standard	2000

Note: Please Consult individual model data sheet to determine device per reel availability.

Mini-Circuits carrier tape materials provide protection from ESD (Electro-Static Discharge) during handling and transportation. Tapes are static dissipative and comply with industry standards EIA-481/EIA-541.

Go to: www.minicircuits.com/pages/pdfs/tape.pdf



INTERNET <http://www.minicircuits.com>

P.O. Box 350166, Brooklyn, New York 11235-0003 (718) 934-4500 Fax (718) 332-4661

Distribution Centers NORTH AMERICA 800-654-7949 • 417-335-5935 • Fax 417-335-5945 • EUROPE 44-1252-832600 • Fax 44-1252-837010

Mini-Circuits ISO 9001 & ISO 14001 Certified

THIRD ANGLE PROJECTION

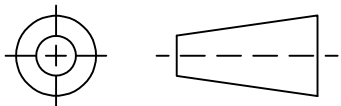

REVISIONS

REV	ECN No.	DESCRIPTION	DATE	DR	AUTH
OR	ECO-012203	NEW RELEASE	03/23/22	ITG	IL

SUGGESTED MOUNTING CONFIGURATION
FOR JV2579 CASE STYLE

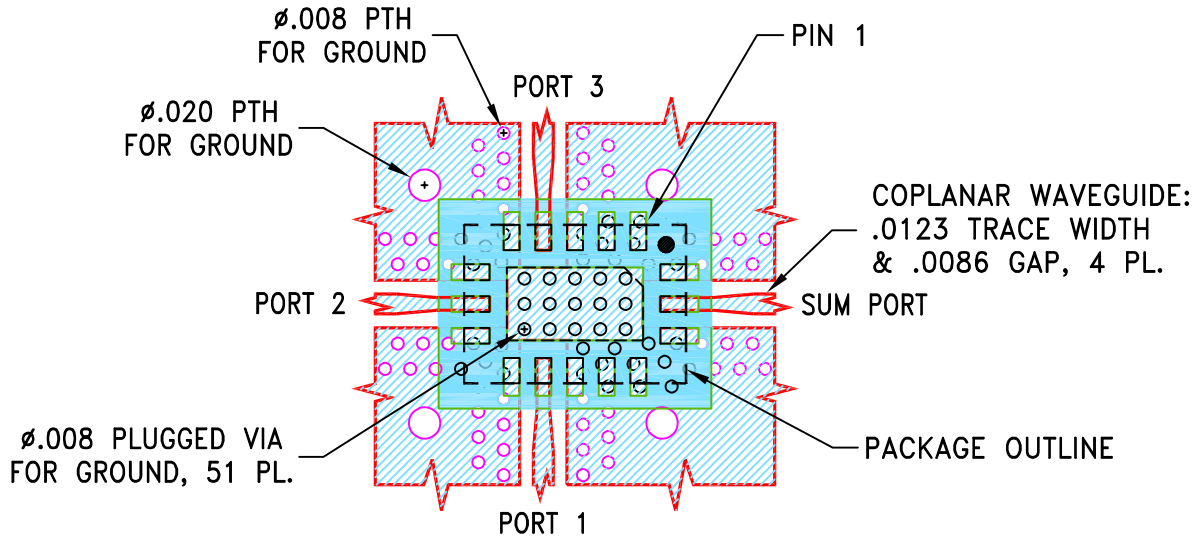

NOTES:

1. TRACE WIDTH & GAP PARAMETERS ARE SHOWN FOR ROGERS R04350B WITH DIELECTRIC THICKNESS .0066±.0007". COPPER: 1/2 OZ. EACH SIDE. FOR OTHER MATERIALS TRACE WIDTH & GAP MAY NEED TO BE MODIFIED.
2. BOTTOM SIDE OF THE PCB IS CONTINUOUS GROUND PLANE.

- DENOTES PCB COPPER LAYOUT WITH SMOBC (SOLDER MASK OVER BARE COPPER).
- DENOTES COPPER LAND PATTERN FREE OF SOLDER MASK.

UNLESS OTHERWISE SPECIFIED	INITIALS		DATE
DIMENSIONS ARE IN INCHES	DRAWN	ITG	03/23/22
TOLERANCES ON:	CHECKED	GF	03/23/22
2 PL DECIMALS ±	APPROVED	IL	03/23/22
3 PL DECIMALS ± .005			
ANGLES ±			
FRACTIONS ±			

Mini-Circuits[®] 13 Neptune Avenue
Brooklyn NY 11235

PL, JV2579, TB-EP3-19+/-19C+

Mini-Circuits[®]
THIS DOCUMENT AND ITS CONTENTS ARE THE PROPERTY OF MINI-CIRCUITS. EXCEPT FOR USE EXPRESSLY GRANTED, IN WRITING, TO ITS VENDORS, VENDEE AND THE UNITED STATES GOVERNMENT, MINI-CIRCUITS RESERVES ALL PROPRIETARY DESIGN, USE, MANUFACTURING AND REPRODUCTION RIGHTS THERETO. THESE CONTENTS SHALL NOT BE USED, DUPLICATED OR DISCLOSED TO ANY OUTSIDE PARTY, IN WHOLE OR IN PART, WITHOUT WRITTEN PERMISSION OF MINI-CIRCUITS.

ASHEETA1.DWG REV:A DATE:01/12/95

SIZE	CODE IDENT	DRAWING NO:	REV:
A	15542	98-PL-728	OR
FILE:	98PL728	SCALE: 8:1	SHEET: 1 OF 1



All Mini-Circuits products are manufactured under exacting quality assurance and control standards, and are capable of meeting published specifications after being subjected to any or all of the following physical and environmental test.

Specification	Test/Inspection Condition	Reference/Spec
Operating Temperature	-55° to 105°C Ambient Environment	Individual Model Data Sheet
Storage Temperature	-65° to 150° C Ambient Environment	Individual Model Data Sheet
Autoclave	15 psig, 100% RH, 121°C, 96 hours	JESD22-A102-C, Condition C
Temperature Cycling	-65° to 150°C, 100 cycles	JESD22-A104
Temperature Humidity	85°C/ 85% RH, 168 hours	JESD22-113
Solder Reflow Heat	Sn-Pb Eutetic Process: 240°C peak Pb-Free Process: 260°C peak	J-STD-020, Table 4-1, 4-2 and 5-2; Figure 5-1
Moisture Sensitivity: Level 1	Bake at 125°C for 24 hours Soak at 85°C/85% RH for 168 hours, Reflow 3 cycles at 240°C peak (Non-RoHS) or 260°C (RoHS)	J-STD-020C
Solderability	10X magnification, 95% coverage	JESD22-B102, Method 1: Dip and Look Test
Marking Resistance to Solvents	Isopropyl alcohol + mineral spirits at 25°C; terpene defluxer at 25°C; distilled water + proylene glycol monomethyl ether + monoethanolamine at 63°C to 70°C	MIL-STD-202, Method 215