

Surface Mount

Monolithic Amplifier

ERA-9SM+

50Ω DC to 8 GHz



Micro-X, 0.085" diameter

The Big Deal

- Low Gain
- Good Gain flatness, ± 0.9 dB
- Broadband matched
- Suitable for low phase noise applications

Product Overview

ERA-9SM+ (RoHS compliant) is wideband current driven amplifier fabricated using HBT technology. In addition, the ERA-9SM+, has good input and output return loss over a broad frequency range without the need for external matching components. It has repeatable performance from lot to lot and is enclosed in a 0.085" diameter micro-x package for very good thermal performance.

Key Features

Feature	Advantages
Broadband, DC* to 8 GHz (* Low frequency cut off determined by external coupling capacitors)	A single amplifier covering DC* to 8 band. <ul style="list-style-type: none">• Reduced component inventory• Ideal for wideband applications such as instrumentation and military
Low gain: 8.6 dB typ. at 0.1 GHz and 6.9 dB at 8 GHz	Ideal for increasing the gain of amplifier chain by low value. Typically small gain change may need two components; an amplifier and an attenuator. Use of ERA-9SM+ reduces component count.
Good Gain Flatness: ± 0.9 dB	No need for gain flatness compensation over 8 GHz band to realize published gain flatness.
Wideband matched Input return loss: 18-25 dB typ. Output return loss: 12-37 dB typ.	No external matching required to realize published return loss.
Low additive phase noise, typically -173 dBc/Hz @ 10 KHz offset	Ideal for low phase noise synthesizer applications

Notes

- A. Performance and quality attributes and conditions not expressly stated in this specification document are intended to be excluded and do not form a part of this specification document.
B. Electrical specifications and performance data contained in this specification document are based on Mini-Circuit's applicable established test performance criteria and measurement instructions.
C. The parts covered by this specification document are subject to Mini-Circuits standard limited warranty and terms and conditions (collectively, "Standard Terms"); Purchasers of this part are entitled to the rights and benefits contained therein. For a full statement of the Standard Terms and the exclusive rights and remedies thereunder, please visit Mini-Circuits' website at www.minicircuits.com/MCLStore/terms.jsp



Surface Mount

Monolithic Amplifier

DC-8 GHz

Product Features

- DC-8 GHz
- Gain, 8.4 dB typ. at 2 GHz
- Good gain flatness, ± 0.9 dB typ.
- Output power, 13.8 dBm typ. at 2 GHz
- Internally Matched to 50 Ohms
- Aqueous washable
- Protected by US Patent 6,943,629



Generic photo used for illustration purposes only

ERA-9SM+

CASE STYLE: WW107

+RoHS Compliant

The +Suffix identifies RoHS Compliance. See our web site for RoHS Compliance methodologies and qualifications

Typical Applications

- Cellular
- PCS
- Communication receivers & transmitters
- Satellite communication, military

General Description

ERA-9SM+ (RoHS compliant) is a wideband current driven low gain, amplifier offering medium dynamic range. It has repeatable performance from lot to lot. It is enclosed in a 0.085" diameter micro-x package.

simplified schematic and pin description

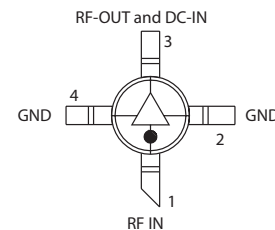
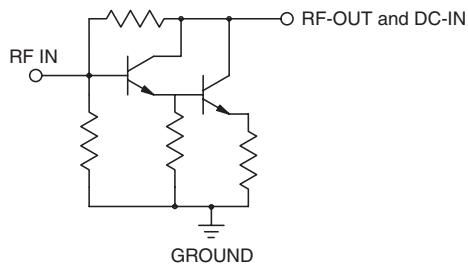

Function	Pin Number	Description
RF IN	1	RF input pin. This pin requires the use of an external DC blocking capacitor chosen for the frequency of operation.
RF-OUT and DC-IN	3	RF output and bias pin. DC voltage is present on this pin; therefore a DC blocking capacitor is necessary for proper operation. An RF choke is needed to feed DC bias without loss of RF signal due to the bias connection, as shown in "Recommended Application Circuit".
GND	2,4	Connections to ground. Use via holes as shown in "Suggested Layout for PCB Design" to reduce ground path inductance for best performance.

Notes

- A. Performance and quality attributes and conditions not expressly stated in this specification document are intended to be excluded and do not form a part of this specification document.
B. Electrical specifications and performance data contained in this specification document are based on Mini-Circuit's applicable established test performance criteria and measurement instructions.
C. The parts covered by this specification document are subject to Mini-Circuits standard limited warranty and terms and conditions (collectively, "Standard Terms"); Purchasers of this part are entitled to the rights and benefits contained therein. For a full statement of the Standard Terms and the exclusive rights and remedies thereunder, please visit Mini-Circuits' website at www.minicircuits.com/MCLStore/terms.jsp



Electrical Specifications at 25°C and 50mA, unless noted

Parameter	Condition (GHz)	Min.	Typ.	Max.	Units
Frequency Range*		DC		8	GHz
Gain	0.1	—	8.6	—	dB
	1	—	8.5	—	
	2	7.4	8.3	9.0	
	4	—	7.8	—	
	5	—	7.4	—	
	8	—	6.9	—	
Input Return Loss	0.1		24.0		dB
	1		24.4		
	2		25.0		
	4		24.0		
	5		21.9		
	8		18.6		
Output Return Loss	0.1		37.3		dB
	1		32.4		
	2		23.8		
	4		17.8		
	5		15.5		
	8		11.9		
Output IP3	0.1		31.1		dBm
	1		31.3		
	2		30.1		
	4		25.4		
	5		23.4		
	8		19.4		
Output Power @ 1 dB compression	0.1	—	14.3	—	dBm
	1	—	14.1	—	
	2	12.8	14.1	—	
	4	—	12.5	—	
	5	—	10.9	—	
	8	—	7.9	—	
Noise Figure	0.1		5.1		dB
	1		5.3		
	2		5.3		
	4		5.3		
	5		5.3		
	8		5.4		
Additive phase noise	2.0 GHz, 10KHz offset	—	-173	—	dBc/Hz
Recommended Device Operating Current (Id)			50		mA
Device Operating Voltage (Vd)		3.6	4.0	4.4	V
Device Voltage Variation vs. Temperature at 50 mA			-2.6		mV/°C
Device Voltage Variation vs. Current at 25°C			17.5		mV/mA
Thermal Resistance, junction-to-case ¹			138		°C/W

*Low frequency cut off determined by external coupling capacitors.

Absolute Maximum Ratings

Parameter	Ratings
Operating Temperature*	-40°C to 85°C
Storage Temperature	-65°C to 150°C
Operating Current	74 mA
Input Power	26 dBm (5 min max.) 15 dBm (continuous)

Note: Permanent damage may occur if any of these limits are exceeded.
 These ratings are not intended for continuous normal operation.
¹Case is defined as ground leads.

Notes

- A. Performance and quality attributes and conditions not expressly stated in this specification document are intended to be excluded and do not form a part of this specification document.
- B. Electrical specifications and performance data contained in this specification document are based on Mini-Circuit's applicable established test performance criteria and measurement instructions.
- C. The parts covered by this specification document are subject to Mini-Circuits standard limited warranty and terms and conditions (collectively, "Standard Terms"); Purchasers of this part are entitled to the rights and benefits contained therein. For a full statement of the Standard Terms and the exclusive rights and remedies thereunder, please visit Mini-Circuits' website at www.minicircuits.com/MCLStore/terms.jsp



Characterization Test Circuit

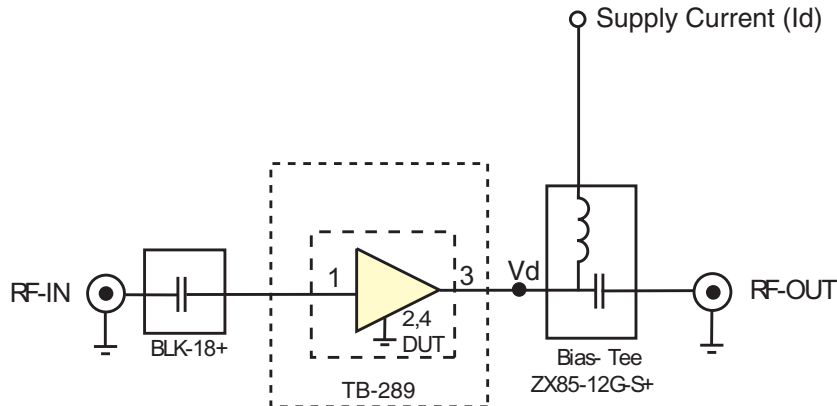
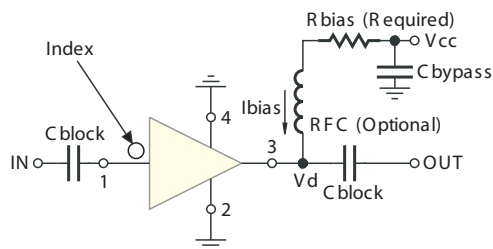

Fig 1. Block Diagram of Test Circuit used for characterization. (DUT soldered on Mini-Circuits Characterization test board TB-289) Gain, Return loss, Output power at 1dB compression (P1 dB) , output IP3 (OIP3) and noise figure measured using Agilent’s N5242A PNA-X microwave network analyzer.

Conditions:

1. Gain and Return loss: Pin= -25dBm
2. Output IP3 (OIP3): Two tones, spaced 1 MHz apart, -5 dBm/tone at output.

Recommended Application Circuit



Test Board includes case, connectors, and components (in bold) soldered to PCB

Product Marking

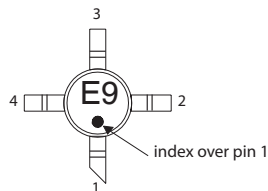

Markings in addition to model number designation may appear for internal quality control purposes.

R BIAS	
Vcc	“1%” Res. Values (ohms) for Optimum Biasing
7	61.9
8	80.6
9	100
10	121
11	140
12	165
13	182
14	200
15	221
16	237
17	261
18	274
19	301
20	316

Notes

- A. Performance and quality attributes and conditions not expressly stated in this specification document are intended to be excluded and do not form a part of this specification document.
- B. Electrical specifications and performance data contained in this specification document are based on Mini-Circuit’s applicable established test performance criteria and measurement instructions.
- C. The parts covered by this specification document are subject to Mini-Circuits standard limited warranty and terms and conditions (collectively, “Standard Terms”); Purchasers of this part are entitled to the rights and benefits contained therein. For a full statement of the Standard Terms and the exclusive rights and remedies thereunder, please visit Mini-Circuits’ website at www.minicircuits.com/MCLStore/terms.jsp



Additional Detailed Technical Information	
<i>additional information is available on our dash board. To access this information click here</i>	
Performance Data	Data Table
	Swept Graphs
	S-Parameter (S2P Files) Data Set (.zip file)
Case Style	WW107, Plastic micro-x 0.085 <i>body diameter</i> , <i>lead finish: Matte-Tin</i>
Tape & Reel Standard quantities available on reel	F4 <i>7" Reels with 20, 50, 100, 200, 500, 1K devices</i>
Suggested Layout for PCB Design	98-PL-075
Evaluation Board	TB-408-9SM+
Environmental Ratings	ENV08T1

ESD Rating

Human Body Model (HBM): Class 1B (500 to <1000V) in accordance with ANSI/ESD STM 5.1 - 2001

Machine Model (MM): Class M1(25V) in accordance with ANSI/ESD STM5.2-1999

MSL Rating

Moisture Sensitivity: MSL1 in accordance with IPC/JEDEC J-STD-020D

MSL Test Flow Chart

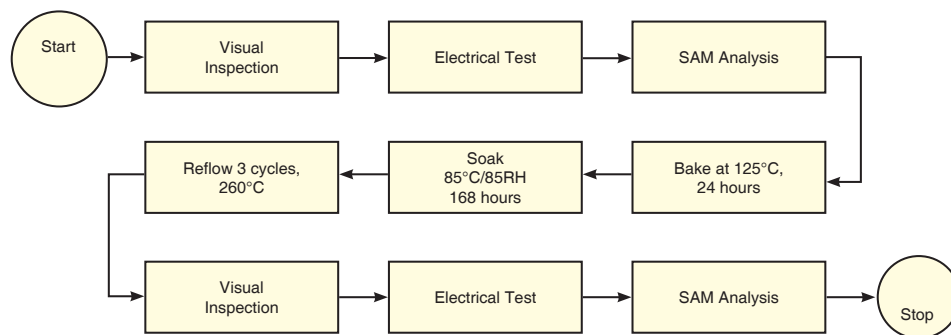

Notes

- A. Performance and quality attributes and conditions not expressly stated in this specification document are intended to be excluded and do not form a part of this specification document.
- B. Electrical specifications and performance data contained in this specification document are based on Mini-Circuit's applicable established test performance criteria and measurement instructions.
- C. The parts covered by this specification document are subject to Mini-Circuits standard limited warranty and terms and conditions (collectively, "Standard Terms"); Purchasers of this part are entitled to the rights and benefits contained therein. For a full statement of the Standard Terms and the exclusive rights and remedies thereunder, please visit Mini-Circuits' website at www.minicircuits.com/MCLStore/terms.jsp



Typical Performance Data

NOTE: Use PDF Bookmarks to view DATA at required conditions

Definitions:

Input Return Loss = -S11 (dB)

Gain(Power Gain) = S21 (dB)

Reverse Isolation = -S12 (dB)

Output Return Loss = -S22 (dB)

TEST CONDITIONS: Id =50mA, Vd = 4.1V, @ Temperature = +25degC

FREQ	Gain	Isolation	Input Return Loss	Output Return Loss	Stability		IP-3 Output	1dB Comp. Output	Noise Figure
					K	Measure			
(MHz)	(dB)	(dB)	(dB)	(dB)	K	Measure	(dBm)	(dBm)	(dB)
10.0	8.58	15.30	22.68	41.72	1.31	0.79	30.97	13.93	5.24
50.0	8.61	15.15	23.12	37.24	1.29	0.78	33.94	14.44	5.09
100.0	8.60	15.10	23.28	38.13	1.29	0.78	32.96	14.31	5.05
200.0	8.59	15.12	23.10	38.00	1.29	0.78	33.34	14.15	5.00
300.0	8.58	15.12	23.29	38.38	1.29	0.78	32.93	14.21	5.51
400.0	8.57	15.12	23.47	37.93	1.29	0.78	31.73	14.21	5.17
500.0	8.55	15.12	23.61	37.96	1.30	0.78	31.76	14.19	5.52
600.0	8.55	15.12	23.84	37.45	1.30	0.78	32.54	14.23	5.22
700.0	8.53	15.12	24.22	36.18	1.30	0.78	33.15	14.18	5.27
800.0	8.52	15.13	24.46	35.03	1.30	0.79	33.49	14.18	5.28
1000.0	8.50	15.12	24.96	32.47	1.30	0.79	31.54	14.08	5.26
1250.0	8.46	15.14	25.59	29.44	1.30	0.79	32.66	14.08	5.17
1500.0	8.41	15.14	25.99	27.03	1.31	0.79	31.14	14.09	5.16
1750.0	8.36	15.13	26.05	25.44	1.31	0.79	30.53	14.13	5.18
2000.0	8.30	15.17	25.78	24.13	1.32	0.79	30.73	14.06	5.25
2250.0	8.25	15.13	26.14	23.41	1.32	0.79	30.31	13.99	5.22
2500.0	8.19	15.16	25.98	22.75	1.33	0.80	29.18	13.89	5.14
2750.0	8.12	15.17	26.01	22.51	1.34	0.80	28.53	13.77	5.19
3000.0	8.06	15.17	26.35	22.24	1.34	0.80	27.87	13.55	5.23
3250.0	8.00	15.16	26.66	21.99	1.35	0.80	27.37	13.28	5.16
3500.0	7.89	15.20	26.29	21.18	1.36	0.81	26.82	12.95	5.28
3750.0	7.84	15.18	26.84	21.16	1.37	0.81	26.02	12.68	5.16
4000.0	7.75	15.16	27.26	19.97	1.37	0.81	25.54	12.43	5.12
4250.0	7.65	15.21	26.88	19.03	1.39	0.81	25.23	11.86	5.11
4500.0	7.60	15.19	27.45	18.34	1.39	0.81	24.71	11.65	5.22
4750.0	7.42	15.14	25.31	16.75	1.40	0.81	24.40	11.46	5.20
5000.0	7.20	15.34	24.07	16.26	1.44	0.82	23.74	11.05	5.24
5250.0	7.25	15.24	24.84	15.77	1.42	0.81	23.15	10.67	5.24
5500.0	7.17	15.29	24.59	15.28	1.44	0.81	23.25	10.72	5.09
5750.0	7.13	15.18	24.18	14.59	1.42	0.80	22.92	10.30	5.13
6000.0	7.05	15.39	25.70	14.82	1.46	0.82	22.32	9.99	5.15
6250.0	6.99	15.20	24.77	14.22	1.44	0.81	22.13	9.75	5.15
6500.0	6.86	15.22	25.51	14.26	1.46	0.81	21.83	9.57	5.14
6750.0	6.68	15.12	24.75	14.19	1.47	0.81	21.16	9.19	5.18
7000.0	6.88	15.26	30.14	14.70	1.46	0.82	21.22	9.08	5.24
7250.0	6.82	15.19	30.89	14.89	1.46	0.82	21.11	8.92	5.21
7500.0	6.85	15.11	29.99	14.80	1.45	0.82	20.30	8.47	5.20
7750.0	6.92	15.11	29.93	14.54	1.44	0.81	20.15	8.27	5.27
8000.0	6.98	15.07	27.54	14.02	1.42	0.80	20.34	8.03	5.17

Typical Performance Data

Definitions:

Input Return Loss = -S11 (dB)

Gain(Power Gain) = S21 (dB)

Reverse Isolation = -S12 (dB)

Output Return Loss = -S22 (dB)

TEST CONDITIONS: Id =40mA, Vd = 3.93V, @ Temperature = +25degC

FREQ	Gain	Isolation	Input Return Loss	Output Return Loss	Stability		IP-3 Output	1dB Comp. Output	Noise Figure
					K	Measure			
(MHz)	(dB)	(dB)	(dB)	(dB)	K	Measure	(dBm)	(dBm)	(dB)
10.0	8.47	15.27	22.05	37.12	1.32	0.80	28.86	12.06	5.15
50.0	8.50	15.06	22.30	32.99	1.29	0.78	28.97	12.20	5.03
100.0	8.48	15.05	22.46	33.71	1.29	0.78	29.25	12.19	5.01
200.0	8.47	15.03	22.28	33.52	1.29	0.78	28.40	11.89	4.93
300.0	8.46	15.03	22.51	34.18	1.30	0.78	29.00	11.94	5.05
400.0	8.45	15.05	22.65	34.62	1.30	0.79	28.84	12.12	5.14
500.0	8.44	15.05	22.81	35.12	1.30	0.79	28.89	12.01	5.11
600.0	8.43	15.04	23.03	35.93	1.30	0.79	29.24	12.11	5.17
700.0	8.42	15.05	23.40	36.04	1.30	0.79	28.89	12.13	5.15
800.0	8.41	15.04	23.62	36.22	1.30	0.79	29.66	12.15	5.10
1000.0	8.39	15.05	24.16	34.91	1.30	0.79	28.06	11.97	5.17
1250.0	8.35	15.05	24.87	31.61	1.31	0.79	29.25	11.98	5.14
1500.0	8.31	15.06	25.53	28.76	1.31	0.79	29.25	12.09	5.09
1750.0	8.26	15.05	25.75	26.86	1.31	0.79	28.63	12.20	5.10
2000.0	8.21	15.09	25.74	25.31	1.32	0.80	28.67	12.11	5.15
2250.0	8.16	15.05	26.14	24.38	1.32	0.79	27.99	12.11	5.13
2500.0	8.11	15.08	26.19	23.63	1.33	0.80	27.80	12.11	5.11
2750.0	8.04	15.09	26.26	23.22	1.34	0.80	27.31	12.18	5.11
3000.0	7.99	15.08	26.60	22.89	1.34	0.80	26.75	12.21	5.04
3250.0	7.92	15.08	26.98	22.54	1.35	0.80	26.22	12.07	5.02
3500.0	7.83	15.11	26.85	21.68	1.36	0.81	25.76	11.84	5.14
3750.0	7.78	15.11	27.51	21.59	1.37	0.81	25.17	11.71	5.09
4000.0	7.69	15.08	28.32	20.35	1.37	0.81	24.59	11.41	4.97
4250.0	7.59	15.10	28.23	19.34	1.38	0.81	24.15	10.93	5.02
4500.0	7.54	15.11	29.11	18.60	1.39	0.81	23.70	10.72	5.07
4750.0	7.37	15.06	26.76	16.98	1.40	0.81	23.48	10.53	5.07
5000.0	7.16	15.26	25.28	16.44	1.44	0.82	22.81	10.11	5.12
5250.0	7.21	15.17	26.16	15.93	1.42	0.81	22.30	9.81	5.05
5500.0	7.13	15.21	25.79	15.42	1.43	0.81	22.37	9.80	4.94
5750.0	7.09	15.10	25.01	14.67	1.42	0.80	21.93	9.37	4.97
6000.0	7.02	15.33	26.63	14.92	1.46	0.82	21.46	9.11	5.04
6250.0	6.96	15.14	25.28	14.28	1.43	0.81	21.24	8.89	5.04
6500.0	6.82	15.16	25.87	14.33	1.45	0.81	20.95	8.66	5.00
6750.0	6.64	15.06	25.00	14.23	1.46	0.82	20.25	8.35	5.06
7000.0	6.85	15.20	29.90	14.75	1.46	0.82	20.29	8.22	4.96
7250.0	6.78	15.14	30.71	14.95	1.46	0.82	20.15	8.02	5.10
7500.0	6.81	15.06	29.36	14.84	1.44	0.82	19.35	7.57	5.04
7750.0	6.89	15.06	28.79	14.54	1.43	0.81	19.23	7.38	5.13
8000.0	6.94	15.02	26.37	14.04	1.41	0.81	19.24	7.14	5.02

Typical Performance Data

Definitions:

Input Return Loss = -S11 (dB)

Gain(Power Gain) = S21 (dB)

Reverse Isolation = -S12 (dB)

Output Return Loss = -S22 (dB)

TEST CONDITIONS: Id =60mA, Vd = 4.29V, @ Temperature = +25degC

FREQ	Gain	Isolation	Input Return Loss	Output Return Loss	Stability		IP-3 Output	1dB Comp. Output	Noise Figure
					K	Measure			
(MHz)	(dB)	(dB)	(dB)	(dB)	K	Measure	(dBm)	(dBm)	(dB)
10.0	8.67	14.85	23.78	37.72	1.26	0.76	28.75	14.45	5.28
50.0	8.69	15.15	23.74	40.99	1.29	0.78	37.19	15.67	5.18
100.0	8.67	15.17	23.80	43.33	1.29	0.78	36.27	15.46	5.15
200.0	8.66	15.15	23.67	41.48	1.29	0.78	35.19	15.42	5.09
300.0	8.65	15.16	23.90	40.40	1.29	0.78	33.55	15.48	5.24
400.0	8.64	15.16	24.05	39.68	1.29	0.78	34.96	15.37	5.27
500.0	8.63	15.15	24.17	38.40	1.29	0.78	33.61	15.36	5.26
600.0	8.62	15.15	24.42	36.66	1.29	0.78	33.99	15.35	5.30
700.0	8.61	15.16	24.77	34.87	1.29	0.78	35.20	15.26	5.28
800.0	8.59	15.17	25.01	33.39	1.30	0.78	35.25	15.23	5.26
1000.0	8.56	15.17	25.38	31.00	1.30	0.79	33.20	15.21	5.29
1250.0	8.53	15.17	25.99	28.19	1.30	0.79	31.92	15.19	5.25
1500.0	8.48	15.18	26.31	26.16	1.31	0.79	32.85	15.11	5.25
1750.0	8.42	15.18	26.13	24.64	1.31	0.79	32.01	15.06	5.24
2000.0	8.36	15.20	25.75	23.50	1.32	0.79	32.35	14.96	5.28
2250.0	8.31	15.17	25.94	22.85	1.32	0.79	30.79	14.84	5.31
2500.0	8.25	15.20	25.83	22.27	1.33	0.79	29.74	14.70	5.27
2750.0	8.17	15.22	25.76	22.07	1.34	0.80	29.45	14.46	5.25
3000.0	8.11	15.19	26.12	21.86	1.34	0.80	28.63	14.22	5.20
3250.0	8.04	15.20	26.29	21.64	1.35	0.80	28.08	13.93	5.20
3500.0	7.94	15.23	25.92	20.90	1.36	0.81	27.35	13.66	5.30
3750.0	7.88	15.23	26.39	20.83	1.37	0.81	26.84	13.36	5.29
4000.0	7.79	15.19	26.58	19.75	1.37	0.81	26.12	13.14	5.22
4250.0	7.68	15.22	26.04	18.83	1.38	0.81	25.70	12.63	5.18
4500.0	7.63	15.22	26.39	18.15	1.39	0.81	25.31	12.46	5.24
4750.0	7.45	15.16	24.42	16.63	1.40	0.81	25.12	12.28	5.28
5000.0	7.23	15.36	23.28	16.10	1.44	0.82	24.51	11.91	5.31
5250.0	7.28	15.28	23.97	15.67	1.43	0.81	23.83	11.48	5.23
5500.0	7.20	15.33	23.72	15.19	1.44	0.81	24.05	11.58	5.12
5750.0	7.16	15.21	23.51	14.52	1.42	0.80	23.61	11.11	5.20
6000.0	7.08	15.42	24.77	14.76	1.46	0.82	23.10	10.83	5.27
6250.0	7.03	15.25	24.27	14.21	1.44	0.81	22.89	10.59	5.26
6500.0	6.88	15.24	24.91	14.23	1.46	0.81	22.55	10.41	5.27
6750.0	6.71	15.14	24.35	14.15	1.46	0.81	21.88	10.03	5.34
7000.0	6.91	15.29	29.53	14.71	1.46	0.82	22.01	9.96	5.24
7250.0	6.85	15.23	29.97	14.92	1.46	0.82	21.76	9.79	5.33
7500.0	6.88	15.12	29.84	14.85	1.45	0.81	21.11	9.32	5.31
7750.0	6.96	15.12	30.04	14.58	1.43	0.81	20.92	9.13	5.41
8000.0	7.02	15.07	28.39	14.11	1.42	0.80	20.99	8.88	5.36

Typical Performance Data

Definitions:

Input Return Loss = -S11 (dB)

Gain(Power Gain) = S21 (dB)

Reverse Isolation = -S12 (dB)

Output Return Loss = -S22 (dB)

TEST CONDITIONS: Id =50mA, Vd = 4.29V, @ Temperature = -45degC

FREQ	Gain	Isolation	Input Return Loss	Output Return Loss	Stability		IP-3 Output	1dB Comp. Output	Noise Figure
					K	Measure			
(MHz)	(dB)	(dB)	(dB)	(dB)	K	Measure	(dBm)	(dBm)	(dB)
10.0	8.68	14.93	23.09	35.92	1.27	0.77	30.16	14.03	4.48
50.0	8.69	15.18	22.64	35.59	1.29	0.78	36.25	14.56	4.37
100.0	8.67	15.16	22.06	33.68	1.29	0.78	33.39	14.44	4.32
200.0	8.67	15.13	21.80	32.62	1.28	0.78	34.68	14.23	4.30
300.0	8.66	15.11	23.07	36.78	1.28	0.78	32.55	14.33	4.44
400.0	8.66	15.12	23.69	39.39	1.29	0.78	33.05	14.40	4.50
500.0	8.65	15.13	23.84	38.40	1.29	0.78	32.95	14.37	4.50
600.0	8.65	15.11	24.29	37.04	1.28	0.78	33.75	14.41	4.52
700.0	8.64	15.11	24.36	35.71	1.29	0.78	33.43	14.40	4.50
800.0	8.63	15.11	24.06	35.21	1.29	0.78	33.99	14.39	4.46
1000.0	8.61	15.09	24.10	32.66	1.29	0.78	32.39	14.27	4.46
1250.0	8.58	15.09	25.11	28.55	1.29	0.78	33.85	14.29	4.46
1500.0	8.54	15.09	25.73	25.96	1.29	0.78	32.98	14.35	4.45
1750.0	8.50	15.08	25.73	24.39	1.29	0.78	32.51	14.42	4.46
2000.0	8.45	15.09	25.61	23.14	1.30	0.78	33.92	14.38	4.47
2250.0	8.39	15.06	25.64	22.09	1.30	0.78	31.07	14.35	4.47
2500.0	8.34	15.07	25.57	21.55	1.31	0.78	30.00	14.30	4.37
2750.0	8.28	15.07	25.88	22.33	1.31	0.79	29.99	14.26	4.45
3000.0	8.23	15.04	26.05	22.61	1.31	0.79	28.85	14.17	4.40
3250.0	8.16	15.03	25.98	22.00	1.32	0.79	28.45	13.95	4.32
3500.0	8.07	15.06	25.66	21.13	1.33	0.79	28.40	13.68	4.40
3750.0	8.02	15.04	26.12	21.34	1.33	0.80	27.48	13.42	4.39
4000.0	7.93	15.01	26.08	20.21	1.34	0.80	26.82	13.15	4.32
4250.0	7.83	15.02	25.39	18.94	1.35	0.80	26.55	12.65	4.33
4500.0	7.78	15.01	25.60	18.22	1.35	0.80	25.81	12.41	4.40
4750.0	7.57	15.00	23.12	16.47	1.36	0.79	25.45	12.18	4.39
5000.0	7.39	15.20	22.02	15.90	1.40	0.81	25.18	11.90	4.47
5250.0	7.46	15.03	22.35	15.09	1.37	0.79	24.47	11.50	4.39
5500.0	7.37	15.06	22.54	14.69	1.38	0.79	24.23	11.39	4.23
5750.0	7.27	15.05	22.44	14.12	1.39	0.79	24.13	11.08	4.32
6000.0	7.23	15.22	23.26	14.41	1.42	0.80	23.78	10.74	4.37
6250.0	7.11	14.96	22.41	13.61	1.39	0.79	23.47	10.48	4.31
6500.0	7.02	14.88	23.18	13.53	1.39	0.78	23.00	10.32	4.34
6750.0	6.91	14.82	23.03	13.79	1.40	0.79	22.59	10.11	4.26
7000.0	7.02	14.97	26.24	14.32	1.41	0.80	22.45	9.96	4.33
7250.0	7.04	14.94	27.66	14.68	1.41	0.80	22.36	9.84	4.29
7500.0	7.05	14.94	27.23	15.10	1.41	0.80	21.70	9.41	4.35
7750.0	7.17	14.88	29.37	14.94	1.39	0.79	21.78	9.28	4.40
8000.0	7.22	14.84	29.21	14.31	1.37	0.79	21.80	9.08	4.33

MMIC Amplifier

ERA-9SM+

Typical Performance Data

Definitions:

Input Return Loss = -S11 (dB)

Gain(Power Gain) = S21 (dB)

Reverse Isolation = -S12 (dB)

Output Return Loss = -S22 (dB)

TEST CONDITIONS: Id =40mA, Vd = 4.11V, @ Temperature = -45degC

FREQ	Gain	Isolation	Input Return Loss	Output Return Loss	Stability		IP-3 Output	1dB Comp. Output	Noise Figure
					K	Measure			
(MHz)	(dB)	(dB)	(dB)	(dB)	K	Measure	(dBm)	(dBm)	(dB)
10.0	8.80	16.52	26.59	22.07	1.41	0.83	28.46	12.07	4.46
50.0	8.56	15.14	21.99	32.88	1.30	0.78	30.15	12.17	4.29
100.0	8.55	15.07	21.44	31.23	1.29	0.78	29.62	11.96	4.28
200.0	8.54	15.05	21.20	30.55	1.29	0.78	29.38	11.69	4.25
300.0	8.54	15.05	22.37	34.54	1.29	0.78	29.57	11.79	4.32
400.0	8.53	15.04	23.01	36.81	1.29	0.78	30.59	12.00	4.42
500.0	8.53	15.03	23.04	36.48	1.29	0.78	29.23	11.90	4.38
600.0	8.53	15.03	23.58	36.74	1.29	0.78	29.97	12.01	4.46
700.0	8.52	15.02	23.66	36.36	1.29	0.78	30.31	12.03	4.42
800.0	8.51	15.02	23.39	35.99	1.29	0.78	30.48	12.06	4.37
1000.0	8.49	15.02	23.56	34.05	1.29	0.78	28.96	11.84	4.45
1250.0	8.46	15.02	24.59	30.11	1.29	0.78	30.09	11.91	4.39
1500.0	8.43	15.02	25.26	27.30	1.29	0.78	29.66	12.05	4.39
1750.0	8.39	15.00	25.47	25.41	1.30	0.78	29.47	12.17	4.34
2000.0	8.34	15.01	25.57	24.01	1.30	0.78	29.26	12.09	4.40
2250.0	8.29	15.00	25.74	22.80	1.30	0.78	29.39	12.15	4.37
2500.0	8.24	15.01	25.77	22.19	1.31	0.79	28.51	12.18	4.34
2750.0	8.18	14.99	26.04	22.96	1.32	0.79	28.32	12.24	4.39
3000.0	8.13	14.98	26.31	23.31	1.32	0.79	28.24	12.45	4.35
3250.0	8.07	14.95	26.49	22.61	1.32	0.79	27.44	12.42	4.25
3500.0	7.98	14.98	26.33	21.65	1.33	0.80	27.17	12.26	4.37
3750.0	7.93	14.97	26.81	21.78	1.34	0.80	26.58	12.26	4.34
4000.0	7.84	14.94	26.91	20.58	1.34	0.80	25.99	12.05	4.23
4250.0	7.75	14.97	26.27	19.24	1.35	0.80	25.40	11.63	4.22
4500.0	7.70	14.95	26.81	18.46	1.35	0.80	25.11	11.38	4.28
4750.0	7.50	14.94	24.16	16.75	1.37	0.80	24.76	11.21	4.29
5000.0	7.33	15.13	22.85	16.24	1.40	0.81	24.41	10.92	4.35
5250.0	7.39	14.98	23.12	15.29	1.38	0.79	23.71	10.59	4.26
5500.0	7.30	14.99	23.37	14.90	1.38	0.79	23.48	10.50	4.17
5750.0	7.20	14.98	23.02	14.32	1.39	0.79	23.21	10.20	4.20
6000.0	7.17	15.15	24.14	14.59	1.42	0.80	22.75	9.86	4.24
6250.0	7.07	14.92	23.34	13.78	1.39	0.79	22.53	9.61	4.30
6500.0	6.96	14.83	23.77	13.52	1.39	0.79	22.16	9.45	4.26
6750.0	6.82	14.78	23.36	13.86	1.41	0.79	21.74	9.21	4.24
7000.0	6.95	14.96	27.48	14.41	1.42	0.80	21.60	9.12	4.27
7250.0	6.96	14.85	28.90	14.47	1.40	0.80	21.39	8.94	4.32
7500.0	7.04	14.87	30.30	14.91	1.40	0.80	20.81	8.60	4.29
7750.0	7.10	14.81	30.90	14.66	1.38	0.79	20.79	8.41	4.33
8000.0	7.16	14.82	29.79	14.24	1.37	0.79	20.80	8.17	4.28

Typical Performance Data

Definitions:

Input Return Loss = -S11 (dB)

Gain(Power Gain) = S21 (dB)

Reverse Isolation = -S12 (dB)

Output Return Loss = -S22 (dB)

TEST CONDITIONS: Id =60mA, Vd = 4.46V, @ Temperature = -45degC

FREQ	Gain	Isolation	Input Return Loss	Output Return Loss	Stability		IP-3 Output	1dB Comp. Output	Noise Figure
					K	Measure			
(MHz)	(dB)	(dB)	(dB)	(dB)	K	Measure	(dBm)	(dBm)	(dB)
10.0	8.75	15.35	23.97	51.03	1.30	0.79	30.72	14.64	4.54
50.0	8.75	15.19	22.82	38.43	1.28	0.78	37.24	15.94	4.45
100.0	8.74	15.19	22.46	35.78	1.28	0.78	39.38	15.76	4.41
200.0	8.73	15.17	22.18	34.32	1.28	0.78	33.37	15.69	4.40
300.0	8.72	15.16	23.60	37.79	1.28	0.78	38.54	15.77	4.49
400.0	8.72	15.16	24.19	39.29	1.28	0.78	35.42	15.70	4.55
500.0	8.71	15.14	24.31	37.50	1.28	0.78	34.50	15.70	4.55
600.0	8.71	15.14	24.80	35.59	1.28	0.78	34.14	15.70	4.58
700.0	8.70	15.15	24.86	34.62	1.28	0.78	35.76	15.65	4.59
800.0	8.69	15.16	24.54	33.89	1.28	0.78	35.97	15.63	4.50
1000.0	8.67	15.13	24.47	31.56	1.28	0.78	34.62	15.58	4.57
1250.0	8.64	15.13	25.37	27.61	1.29	0.78	33.81	15.58	4.54
1500.0	8.59	15.12	25.90	25.23	1.29	0.78	32.43	15.55	4.52
1750.0	8.55	15.12	25.72	23.77	1.29	0.78	32.83	15.56	4.48
2000.0	8.49	15.12	25.48	22.58	1.30	0.78	33.67	15.48	4.50
2250.0	8.44	15.08	25.42	21.65	1.30	0.78	31.88	15.37	4.51
2500.0	8.39	15.10	25.33	21.19	1.30	0.78	31.45	15.29	4.49
2750.0	8.32	15.11	25.66	21.96	1.31	0.79	31.07	15.13	4.54
3000.0	8.27	15.07	25.88	22.21	1.31	0.79	30.00	14.93	4.45
3250.0	8.20	15.07	25.71	21.69	1.32	0.79	29.65	14.65	4.43
3500.0	8.11	15.10	25.29	20.85	1.33	0.79	28.55	14.38	4.55
3750.0	8.05	15.08	25.77	21.05	1.34	0.80	27.80	14.03	4.50
4000.0	7.96	15.06	25.57	19.99	1.34	0.80	27.52	13.85	4.43
4250.0	7.86	15.07	24.73	18.75	1.35	0.80	27.04	13.40	4.45
4500.0	7.80	15.06	24.83	18.06	1.35	0.80	26.68	13.12	4.43
4750.0	7.60	15.04	22.48	16.31	1.36	0.80	26.19	12.93	4.51
5000.0	7.41	15.24	21.46	15.80	1.40	0.81	25.92	12.71	4.63
5250.0	7.48	15.09	21.81	15.04	1.38	0.79	25.18	12.23	4.40
5500.0	7.39	15.10	21.99	14.63	1.39	0.79	25.02	12.14	4.39
5750.0	7.29	15.09	21.82	14.09	1.39	0.79	25.08	11.83	4.38
6000.0	7.24	15.25	22.61	14.38	1.42	0.80	24.45	11.52	4.50
6250.0	7.13	15.01	21.93	13.68	1.40	0.79	24.06	11.26	4.40
6500.0	7.04	14.92	22.65	13.53	1.40	0.79	23.76	11.08	4.37
6750.0	6.94	14.86	22.76	13.82	1.40	0.79	23.24	10.84	4.44
7000.0	7.04	14.98	25.40	14.34	1.41	0.80	23.26	10.76	4.49
7250.0	7.06	14.98	26.42	14.76	1.41	0.80	23.04	10.61	4.45
7500.0	7.04	14.90	25.71	15.02	1.40	0.80	22.56	10.21	4.48
7750.0	7.17	14.89	27.48	14.95	1.39	0.79	22.46	10.09	4.52
8000.0	7.21	14.86	27.97	14.36	1.38	0.79	22.53	9.88	4.48

Typical Performance Data

Definitions:

Input Return Loss = -S11 (dB)

Gain(Power Gain) = S21 (dB)

Reverse Isolation = -S12 (dB)

Output Return Loss = -S22 (dB)

TEST CONDITIONS: Id =50mA, Vd = 3.95V, @ Temperature = +85degC

FREQ	Gain	Isolation	Input Return Loss	Output Return Loss	Stability		IP-3 Output	1dB Comp. Output	Noise Figure
					K	Measure			
(MHz)	(dB)	(dB)	(dB)	(dB)	K	Measure	(dBm)	(dBm)	(dB)
10.0	8.53	15.02	22.94	35.86	1.29	0.78	28.81	13.64	5.72
50.0	8.55	15.13	23.48	37.79	1.30	0.78	33.71	14.27	5.62
100.0	8.53	15.08	23.92	40.81	1.29	0.78	32.39	14.16	5.60
200.0	8.52	15.08	24.59	47.94	1.30	0.78	32.39	14.05	5.54
300.0	8.51	15.06	24.60	46.58	1.29	0.78	31.66	14.11	5.74
400.0	8.50	15.08	24.27	41.89	1.30	0.78	31.11	14.05	5.74
500.0	8.48	15.09	23.92	39.81	1.30	0.79	31.83	14.02	5.72
600.0	8.47	15.09	24.04	40.03	1.30	0.79	32.97	14.03	5.78
700.0	8.46	15.09	24.16	39.59	1.30	0.79	31.79	13.97	5.78
800.0	8.45	15.10	24.21	38.40	1.30	0.79	32.43	13.95	5.68
1000.0	8.42	15.10	24.47	35.61	1.31	0.79	30.75	13.87	5.72
1250.0	8.38	15.10	24.80	32.08	1.31	0.79	30.55	13.86	5.75
1500.0	8.33	15.11	25.38	29.13	1.31	0.79	29.83	13.85	5.75
1750.0	8.28	15.13	25.70	26.79	1.32	0.80	30.21	13.85	5.72
2000.0	8.22	15.16	25.78	24.79	1.33	0.80	30.23	13.76	5.75
2250.0	8.17	15.13	26.25	23.71	1.33	0.80	28.89	13.66	5.78
2500.0	8.11	15.15	26.31	22.81	1.34	0.80	27.96	13.50	5.75
2750.0	8.03	15.20	26.18	22.39	1.35	0.80	28.04	13.29	5.73
3000.0	7.98	15.17	26.41	22.24	1.35	0.81	27.61	13.03	5.69
3250.0	7.91	15.17	26.78	21.98	1.36	0.81	26.38	12.72	5.66
3500.0	7.81	15.23	26.74	21.15	1.38	0.81	25.82	12.40	5.73
3750.0	7.76	15.22	27.63	21.12	1.38	0.81	25.12	12.11	5.70
4000.0	7.66	15.21	28.21	19.98	1.39	0.81	24.83	11.83	5.69
4250.0	7.57	15.23	28.48	18.98	1.40	0.82	24.24	11.27	5.57
4500.0	7.50	15.22	29.06	18.06	1.40	0.81	23.72	11.11	5.69
4750.0	7.38	15.15	27.29	16.55	1.40	0.81	23.57	10.95	5.67
5000.0	7.14	15.32	24.96	15.84	1.45	0.82	22.78	10.45	5.72
5250.0	7.14	15.39	26.04	15.60	1.45	0.82	22.29	10.13	5.70
5500.0	7.03	15.36	24.85	14.89	1.46	0.82	22.44	10.12	5.64
5750.0	7.09	15.26	24.88	14.44	1.43	0.81	22.01	9.67	5.60
6000.0	6.83	15.46	25.11	14.50	1.49	0.82	21.38	9.36	5.73
6250.0	6.89	15.33	24.95	14.35	1.46	0.82	21.20	9.19	5.69
6500.0	6.65	15.09	23.23	13.75	1.46	0.81	21.02	8.97	5.72
6750.0	6.61	15.10	24.03	14.16	1.46	0.82	20.29	8.62	5.65
7000.0	6.67	15.19	26.50	14.72	1.47	0.83	20.34	8.44	5.69
7250.0	6.81	15.24	25.79	15.17	1.46	0.83	20.29	8.28	5.64
7500.0	6.79	15.21	27.81	15.25	1.46	0.83	19.21	7.74	5.73
7750.0	6.69	14.99	26.20	14.43	1.44	0.82	19.09	7.56	5.86
8000.0	6.80	15.05	25.24	14.07	1.43	0.81	18.92	7.21	5.78

Typical Performance Data

Definitions:

Input Return Loss = -S11 (dB)

Gain(Power Gain) = S21 (dB)

Reverse Isolation = -S12 (dB)

Output Return Loss = -S22 (dB)

TEST CONDITIONS: Id =40mA, Vd = 3.78V, @ Temperature = +85degC

FREQ	Gain	Isolation	Input Return Loss	Output Return Loss	Stability		IP-3 Output	1dB Comp. Output	Noise Figure
					K	Measure			
(MHz)	(dB)	(dB)	(dB)	(dB)	K	Measure	(dBm)	(dBm)	(dB)
10.0	8.42	15.06	22.55	33.19	1.30	0.79	28.22	11.70	5.62
50.0	8.41	14.96	22.41	32.12	1.29	0.78	30.39	12.38	5.57
100.0	8.40	14.98	22.92	34.75	1.30	0.78	28.98	12.24	5.56
200.0	8.39	15.00	23.40	39.04	1.30	0.79	28.19	12.02	5.48
300.0	8.38	14.99	23.56	39.27	1.30	0.79	28.19	12.05	5.65
400.0	8.37	15.00	23.33	36.40	1.30	0.79	28.97	12.17	5.66
500.0	8.35	15.00	22.98	35.49	1.30	0.79	28.43	12.07	5.70
600.0	8.34	14.99	23.03	36.78	1.30	0.79	28.34	12.16	5.72
700.0	8.33	15.01	23.22	37.83	1.31	0.79	29.52	12.14	5.71
800.0	8.32	15.02	23.33	38.79	1.31	0.79	28.95	12.14	5.64
1000.0	8.30	15.01	23.62	38.18	1.31	0.79	27.68	11.98	5.68
1250.0	8.26	15.03	24.11	35.46	1.31	0.79	28.42	11.97	5.68
1500.0	8.22	15.03	24.85	31.50	1.32	0.80	28.51	12.06	5.67
1750.0	8.17	15.04	25.32	28.57	1.32	0.80	28.41	12.17	5.64
2000.0	8.12	15.09	25.60	26.07	1.33	0.80	28.10	12.09	5.72
2250.0	8.07	15.07	26.15	24.83	1.34	0.80	27.25	12.08	5.72
2500.0	8.01	15.08	26.46	23.73	1.34	0.80	27.16	12.01	5.65
2750.0	7.94	15.13	26.33	23.19	1.35	0.81	26.39	12.02	5.66
3000.0	7.88	15.09	26.51	22.99	1.36	0.81	26.11	11.90	5.67
3250.0	7.83	15.10	26.92	22.62	1.36	0.81	25.26	11.69	5.53
3500.0	7.73	15.11	27.23	21.68	1.37	0.81	24.81	11.38	5.69
3750.0	7.69	15.12	28.11	21.59	1.38	0.81	24.05	11.18	5.56
4000.0	7.59	15.13	29.12	20.42	1.39	0.82	23.72	10.87	5.57
4250.0	7.50	15.14	29.87	19.36	1.40	0.82	23.12	10.38	5.51
4500.0	7.44	15.13	31.17	18.29	1.40	0.81	22.66	10.15	5.54
4750.0	7.32	15.06	29.08	16.74	1.40	0.81	22.42	9.97	5.60
5000.0	7.08	15.25	26.29	16.09	1.45	0.82	21.69	9.50	5.62
5250.0	7.07	15.30	27.14	15.72	1.45	0.82	21.21	9.20	5.62
5500.0	6.96	15.28	25.75	14.96	1.46	0.82	21.38	9.22	5.54
5750.0	7.02	15.22	25.48	14.58	1.44	0.81	20.90	8.73	5.51
6000.0	6.81	15.37	25.72	14.63	1.48	0.82	20.39	8.48	5.61
6250.0	6.81	15.24	24.68	14.36	1.46	0.82	20.36	8.23	5.59
6500.0	6.61	15.03	23.14	13.84	1.45	0.82	19.99	8.07	5.57
6750.0	6.57	15.06	23.76	14.26	1.46	0.82	19.29	7.69	5.53
7000.0	6.60	15.10	25.41	14.72	1.47	0.83	19.31	7.54	5.60
7250.0	6.72	15.19	25.38	15.27	1.47	0.83	19.18	7.31	5.53
7500.0	6.67	15.13	26.05	15.10	1.47	0.83	18.25	6.83	5.60
7750.0	6.62	14.94	24.45	14.33	1.44	0.82	18.11	6.66	5.69
8000.0	6.71	14.96	23.88	14.05	1.43	0.82	17.96	6.30	5.68

Typical Performance Data

Definitions:

Input Return Loss = -S11 (dB)

Gain(Power Gain) = S21 (dB)

Reverse Isolation = -S12 (dB)

Output Return Loss = -S22 (dB)

TEST CONDITIONS: Id =60mA, Vd = 4.12V, @ Temperature = +85degC

FREQ	Gain	Isolation	Input Return Loss	Output Return Loss	Stability		IP-3 Output	1dB Comp. Output	Noise Figure
					K	Measure			
(MHz)	(dB)	(dB)	(dB)	(dB)	K	Measure	(dBm)	(dBm)	(dB)
10.0	8.59	15.08	23.19	39.67	1.29	0.78	30.02	13.74	5.74
50.0	8.63	15.15	23.88	42.96	1.29	0.78	33.78	15.35	5.70
100.0	8.62	15.12	24.70	44.81	1.29	0.78	34.10	15.06	5.66
200.0	8.60	15.13	25.33	43.57	1.29	0.78	33.60	15.10	5.63
300.0	8.59	15.12	25.31	43.74	1.29	0.78	32.67	15.15	5.80
400.0	8.58	15.15	24.93	42.57	1.30	0.78	33.82	14.97	5.80
500.0	8.56	15.13	24.62	39.66	1.30	0.78	37.32	15.00	5.82
600.0	8.55	15.12	24.64	38.86	1.30	0.78	33.86	14.95	5.85
700.0	8.54	15.14	24.82	37.54	1.30	0.78	33.51	14.85	5.81
800.0	8.52	15.14	24.83	36.26	1.30	0.79	32.85	14.80	5.79
1000.0	8.50	15.15	24.99	33.49	1.30	0.79	33.33	14.79	5.83
1250.0	8.46	15.16	25.31	30.43	1.31	0.79	31.55	14.79	5.83
1500.0	8.41	15.17	25.77	27.80	1.31	0.79	31.82	14.64	5.82
1750.0	8.35	15.15	25.88	25.82	1.32	0.79	31.37	14.53	5.78
2000.0	8.29	15.22	25.69	24.03	1.33	0.80	30.43	14.44	5.84
2250.0	8.23	15.17	26.08	23.07	1.33	0.80	29.74	14.30	5.88
2500.0	8.17	15.23	26.12	22.30	1.34	0.80	29.17	14.12	5.80
2750.0	8.09	15.23	26.01	21.90	1.35	0.80	28.58	13.86	5.78
3000.0	8.03	15.22	26.26	21.85	1.35	0.80	28.36	13.60	5.78
3250.0	7.97	15.23	26.52	21.59	1.36	0.81	27.10	13.32	5.69
3500.0	7.86	15.26	26.37	20.89	1.37	0.81	26.68	13.02	5.86
3750.0	7.81	15.28	27.14	20.84	1.38	0.81	25.81	12.76	5.76
4000.0	7.72	15.27	27.55	19.74	1.39	0.81	25.49	12.51	5.78
4250.0	7.62	15.28	27.49	18.79	1.40	0.82	24.93	12.03	5.73
4500.0	7.55	15.27	27.91	17.94	1.40	0.81	24.48	11.86	5.86
4750.0	7.43	15.20	26.13	16.44	1.40	0.81	24.32	11.70	5.76
5000.0	7.18	15.36	24.05	15.69	1.45	0.82	23.63	11.22	5.81
5250.0	7.19	15.41	25.13	15.54	1.45	0.82	23.05	10.90	5.77
5500.0	7.08	15.41	24.28	14.90	1.46	0.82	23.26	10.91	5.71
5750.0	7.13	15.31	24.22	14.40	1.44	0.81	22.79	10.45	5.70
6000.0	6.88	15.54	24.95	14.57	1.50	0.82	22.16	10.17	5.86
6250.0	6.96	15.38	24.84	14.35	1.46	0.82	22.05	9.97	5.81
6500.0	6.69	15.14	23.09	13.75	1.46	0.81	21.78	9.75	5.81
6750.0	6.64	15.14	24.13	14.14	1.47	0.82	21.14	9.39	5.83
7000.0	6.70	15.23	27.30	14.72	1.48	0.83	21.13	9.28	5.89
7250.0	6.80	15.21	25.96	14.94	1.46	0.83	21.00	9.06	5.81
7500.0	6.83	15.24	29.10	15.30	1.46	0.83	20.04	8.52	5.85
7750.0	6.73	14.99	28.10	14.48	1.44	0.81	19.85	8.32	6.02
8000.0	6.86	15.08	26.28	14.14	1.43	0.81	19.82	8.07	5.96

Typical Performance Curves

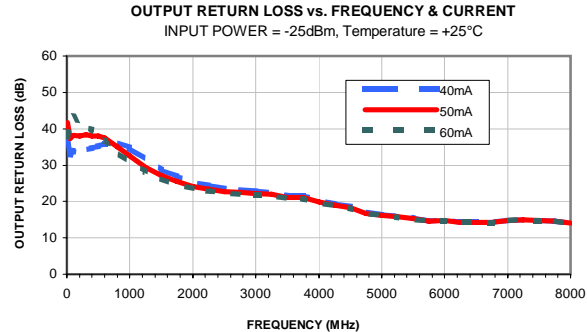
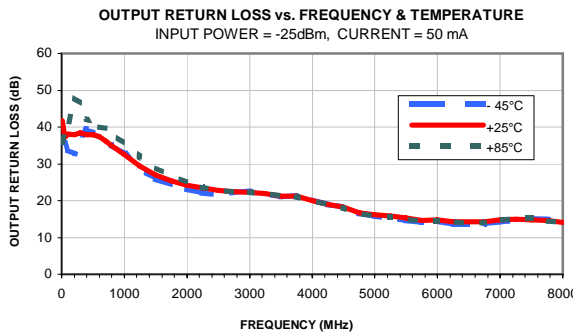
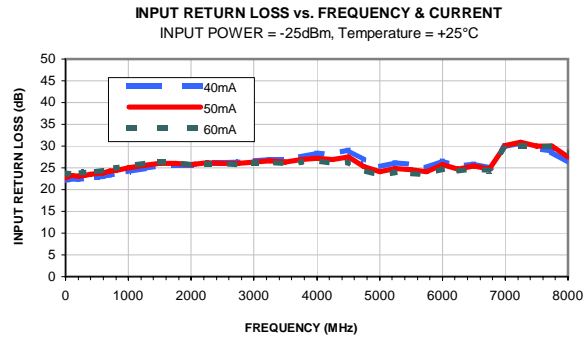
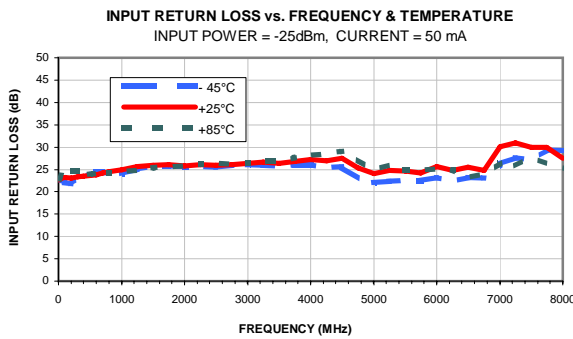
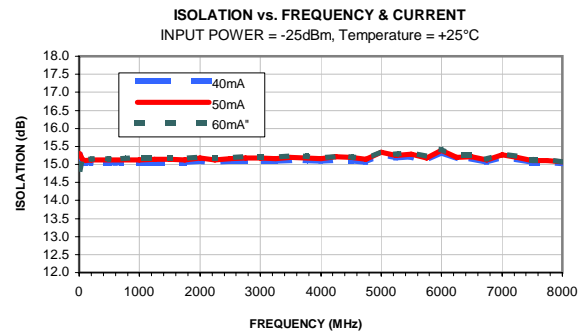
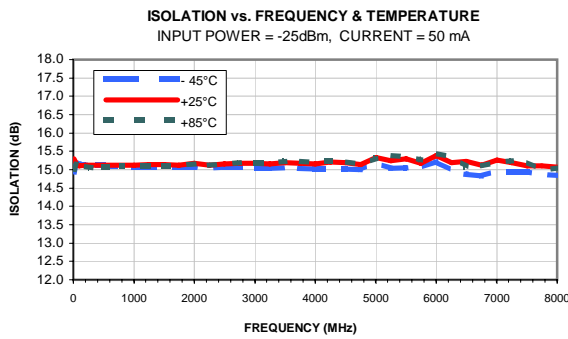
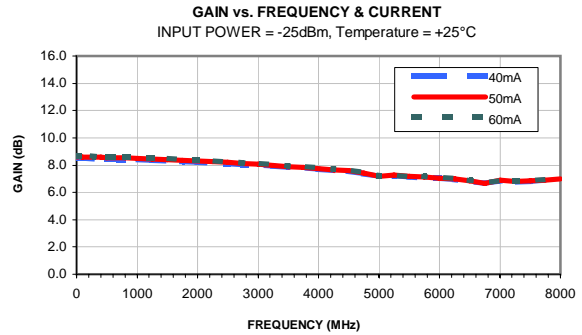
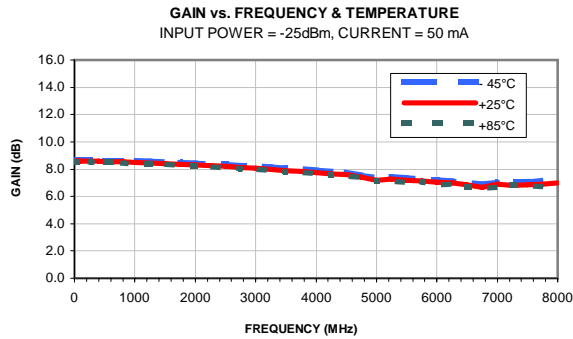

Typical Performance Curves

OUTPUT IP3 vs. FREQUENCY & TEMPERATURE
OUTPUT POWER = -5dBm/1tone, CURRENT = 50 mA

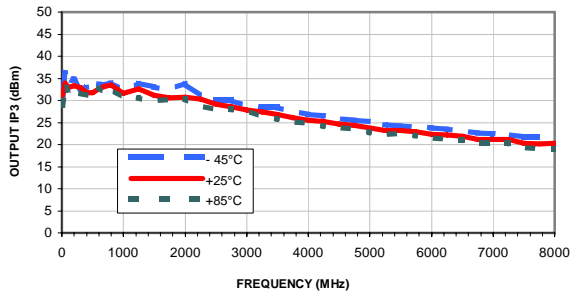

OUTPUT IP3 vs. FREQUENCY & CURRENT
OUTPUT POWER = -5 dBm/1tone, Temperature = +25°C

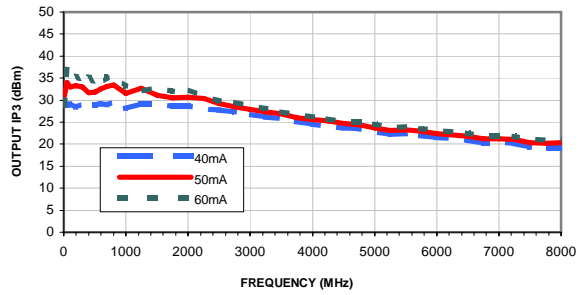

P1dB vs. FREQUENCY & TEMPERATURE
CURRENT = 50 mA

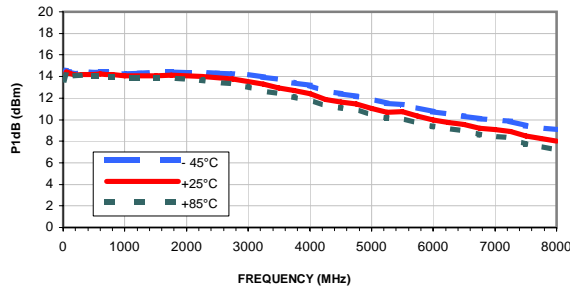

P1dB vs. FREQUENCY & CURRENT
Temperature = +25°C

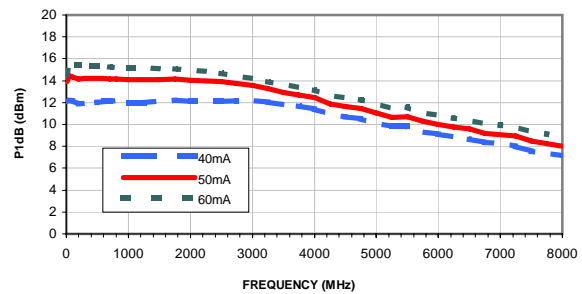

NOISE FIGURE vs. FREQUENCY & TEMPERATURE
CURRENT = 50 mA

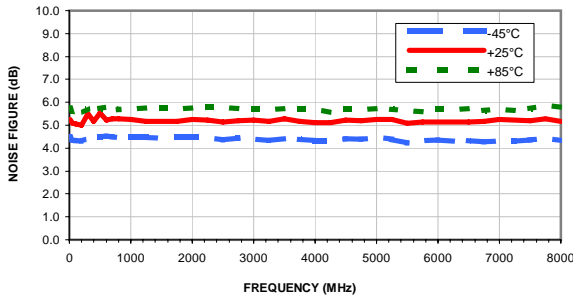

NOISE FIGURE vs. FREQUENCY & CURRENT
Temperature = +25°C

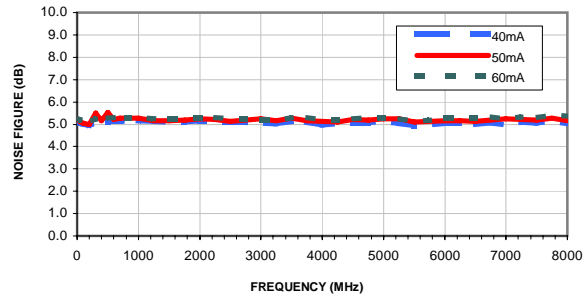

GAIN VARIATION vs. FREQUENCY & TEMPERATURE
INPUT POWER = -25dBm, CURRENT = 50 mA

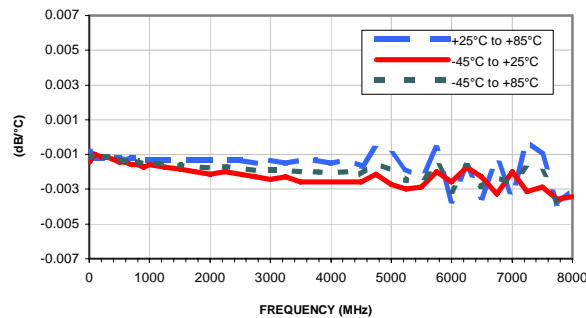

Outline Dimensions

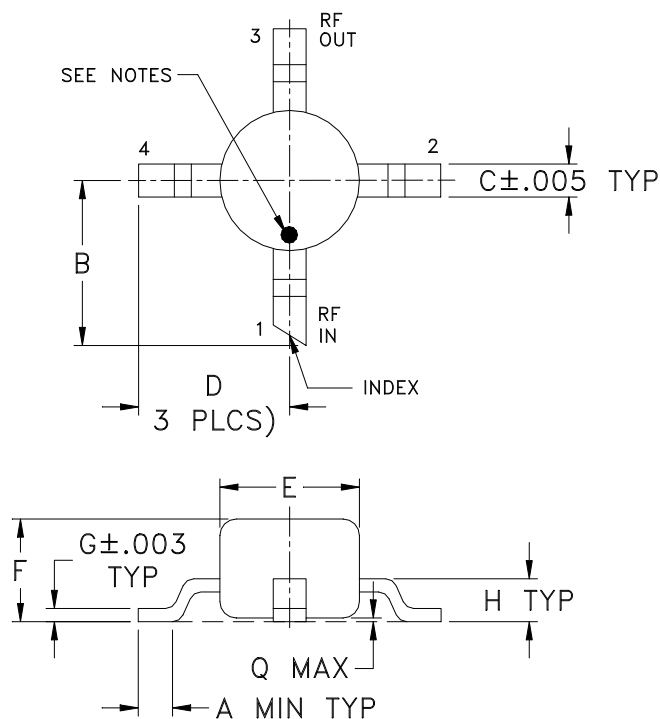

PCB Land Pattern

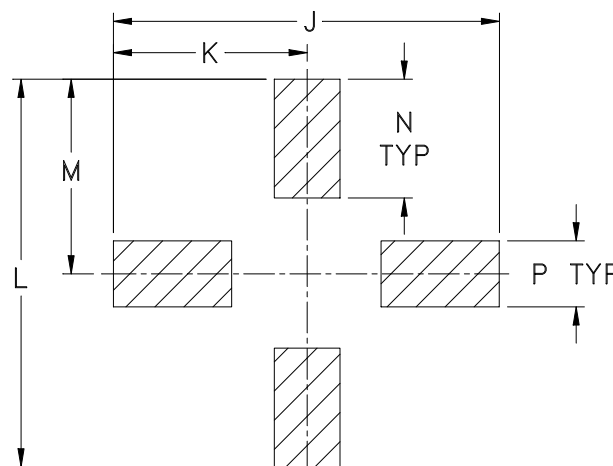

Suggested Layout,
Tolerance to be within $\pm .002$

CASE#	A	B	C	D	E	F	G	H	J	K	L	M	N	P	Q	WT. GRAMS
WW107	.012 (0.30)	.10 (2.54)	.020 (0.51)	.092 (2.34)	.085 (2.16)	.060 (1.52)	.007 (0.18)	.026 (0.66)	.235 (5.97)	.118 (3.00)	.235 (5.97)	.118 (3.00)	.072 (1.83)	.040 (1.02)	.020 (0.51)	.015

Dimensions are in inches (mm). Tolerances: 2 Pl. $\pm .03$; 3 Pl. $\pm .015$

Notes:

- Case material: Plastic.
- Termination finish:
For RoHS Case Styles: Matte tin Plate.
For RoHS-5 Case Styles: Tin-Lead plate.
- RF input termination (1) identified by one or both of the following at factory option:
 - diagonally cut termination, which may be 45° (ref) in either direction;
 - orientation mark on the case. Model dash number is identified by color dot or alphanumeric code on case. See specification data sheet.



INTERNET <http://www.minicircuits.com>

P.O. Box 350166, Brooklyn, New York 11235-0003 (718) 934-4500

Distribution Centers NORTH AMERICA 800-654-7949 • 417-335-5935 • Fax 417-335-5945 • EUROPE 44-1252-1

Mini-Circuits ISO 9001 & ISO 14001 Certified

Tape & Reel Packaging TR-F4

DEVICE ORIENTATION IN T&R

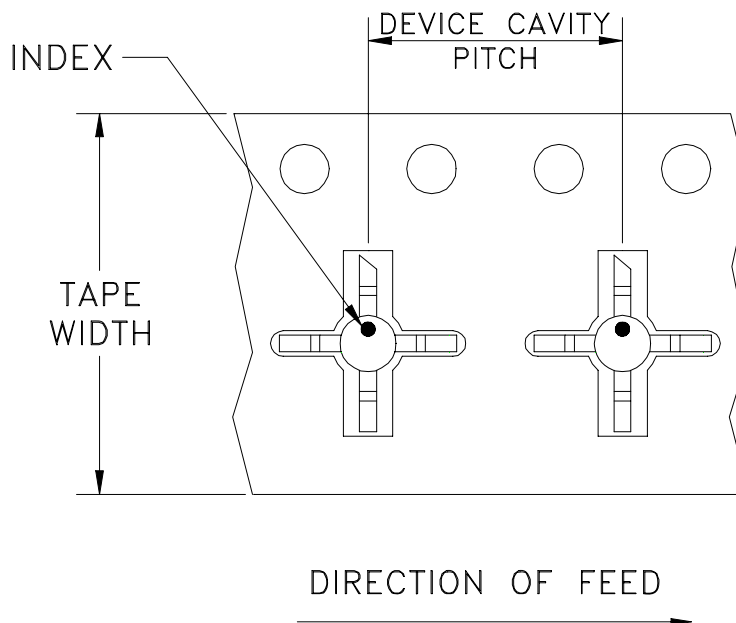

Tape Width, mm	Device Cavity Pitch, mm	Reel Size, inches	Devices per Reel	
12	8	7	Small quantity standards (see note)	20
				50
				100
				200
				500
		7	Standard	1000

Note: Please Consult individual model data sheet to determine device per reel availability.

Mini-Circuits carrier tape materials provide protection from ESD (Electro-Static Discharge) during handling and transportation. Tapes are static dissipative and comply with industry standards EIA-481/EIA-541.

Go to: www.minicircuits.com/pages/pdfs/tape.pdf



INTERNET <http://www.minicircuits.com>

P.O. Box 350166, Brooklyn, New York 11235-0003 (718) 934-4500 Fax (718) 332-4661

Distribution Centers NORTH AMERICA 800-654-7949 • 417-335-5935 • Fax 417-335-5945 • EUROPE 44-1252-832600 • Fax 44-1252-837010

Mini-Circuits ISO 9001 & ISO 14001 Certified

THIRD ANGLE PROJECTION

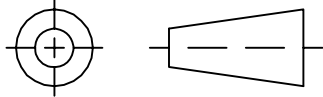

REVISIONS

REV	ECN No.	DESCRIPTION	DATE	DR	AUTH
A	M100215	ADDED "PACKAGE OUTLINE" & UPDATED NOTES	08/12/05	MMG	MM
B	M100944	REMOVED AF190 & UPDATED NOTES	09/23/05	GT	MM
C	M102713	ADDED "...WITH SMOBC"	01/14/06	GF	IL
D	M108434	UPDATED DRAWING PER TB-408+	11/14/06	PW	IG

SUGGESTED MOUNTING CONFIGURATION FOR
WW107 CASE STYLE, "cb" PIN CONNECTION

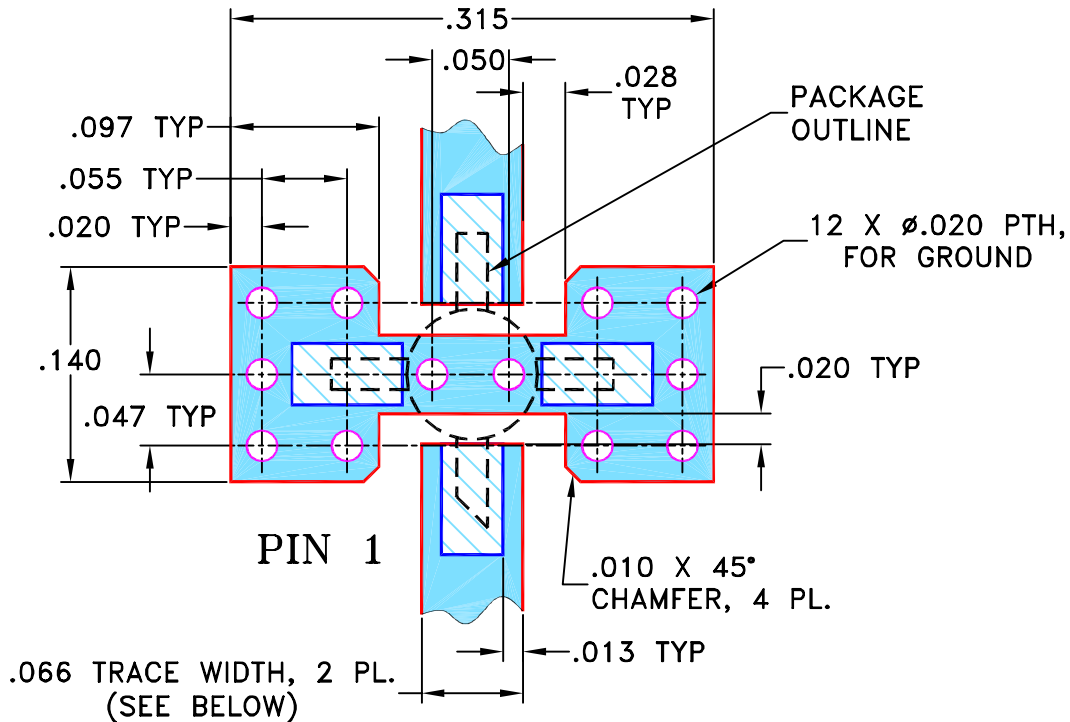

NOTES:

1. TRACE WIDTH IS SHOWN FOR ROGERS R04350B WITH DIELECTRIC THICKNESS .030" ± .002"; COPPER: 1/2 OZ. EACH SIDE. FOR OTHER MATERIALS TRACE WIDTH MAY NEED TO BE MODIFIED.
2. BOTTOM SIDE OF THE PCB IS CONTINUOUS GROUND PLANE.
3. IF PCB DESIGN RULES ALLOW, PLACE GROUND VIAS UNDER THE LAND PATTERN FOR BETTER RF PERFORMANCE. OTHERWISE PLACE GROUND VIAS AS CLOSE TO LAND PATTERN AS POSSIBLE.

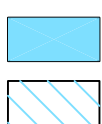

DENOTES PCB COPPER LAYOUT WITH SMOBC (SOLDER MASK OVER BARE COPPER)
DENOTES COPPER LAND PATTERN FREE OF SOLDER MASK

UNLESS OTHERWISE SPECIFIED

INITIALS DATE

DIMENSIONS ARE IN INCHES
TOLERANCES ON:
2 PL DECIMALS ±
3 PL DECIMALS ± .005
ANGLES ±
FRACTIONS ±

DRAWN	GF	07/18/02
CHECKED	LC	08/01/02
APPROVED	DJ	08/05/02



Mini-Circuits®

13 Neptune Avenue
Brooklyn NY 11235

PL, cb, WW107, ERA, TB-408-XX+

Mini-Circuits®
THIS DOCUMENT AND ITS CONTENTS ARE THE PROPERTY OF MINI-CIRCUITS. EXCEPT FOR USE EXPRESSLY GRANTED, IN WRITING, TO ITS VENDORS, VEEDEE AND THE UNITED STATES GOVERNMENT, MINI-CIRCUITS RESERVES ALL PROPRIETARY DESIGN, USE, MANUFACTURING AND REPRODUCTION RIGHTS THERETO. THESE CONTENTS SHALL NOT BE USED, DUPLICATED OR DISCLOSED TO ANY OUTSIDE PARTY, IN WHOLE OR IN PART, WITHOUT WRITTEN PERMISSION OF MINI-CIRCUITS.

SIZE A	CODE IDENT 15542	DRAWING NO: 98-PL-075	REV: D
FILE: 98PL075	SCALE: 8:1	SHEET: 1 OF 1	

ASHEETA1.DWG REV:A DATE:01/12/95

Evaluation Board and Circuit

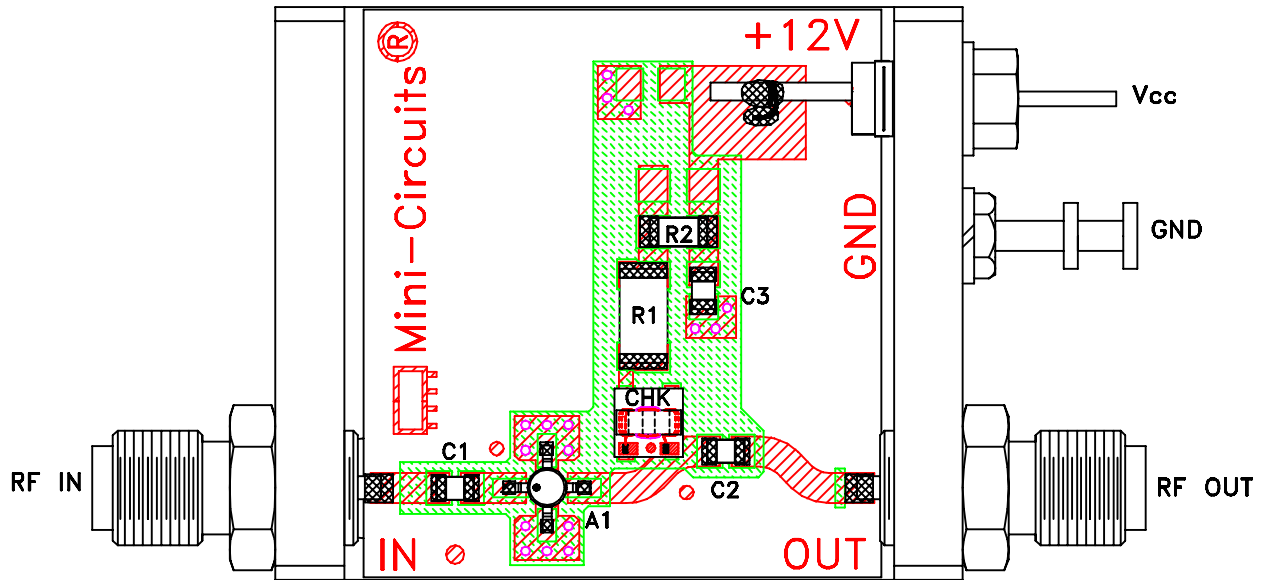

TB-408-9SM+

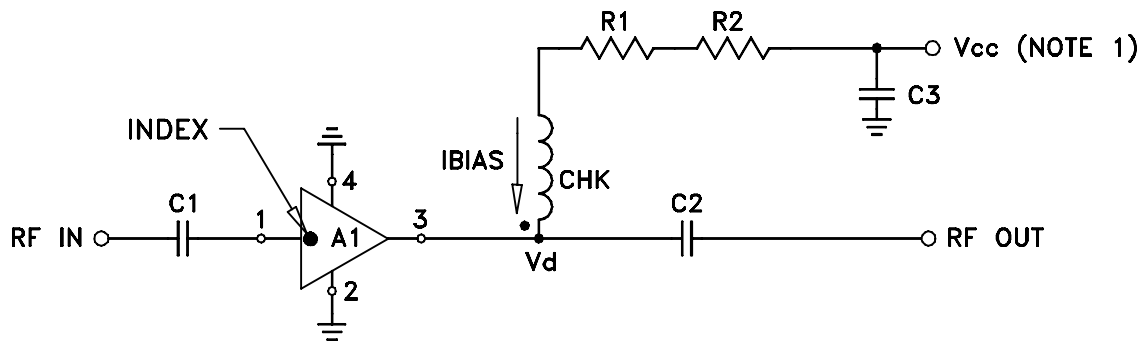

COMPONENT	VALUE
A1	ERA-9SM(+)
C1 (NOTE 4)	2400 pF
C2 (NOTE 4)	2400 pF
C3 (bypass)	0.1 uF
R1	165 Ohms, 0.75W
R2	0 Ohm, 0.25W
CHK	Mini-Circuits TCCH-80+

Schematic Diagram

NOTE:

1. Vcc voltage: $+12 \pm 0.2V$.
2. SMA Female connectors.
3. PCB material: Rogers R04350 or equivalent, dielectric constant=3.5, dielectric thickness=.030 inch.
4. Capacitors, C1 & C2 should be free of resonance up to the highest frequency specified.
5. Insertion loss of Input/Output line :

Frequency, GHz	1.0	2.0	4.0	8.0
Loss,dB*	0.5	0.8	1.2	1.6

* Add PCB loss to measured Gain to get DUT Gain.

Mini-Circuits®

All Mini-Circuits products are manufactured under exacting quality assurance and control standards, and are capable of meeting published specifications after being subjected to any or all of the following physical and environmental test.

Specification	Test/Inspection Condition	Reference/Spec
Operating Temperature	-40° to 85°C or -45° to 85°C Ambient Environment	Individual Model Data Sheet
Storage Temperature	-55° to 100° C or -65° to 150° Ambient Environment	Individual Model Data Sheet
Thermal Shock	-55° to 100°C, 100 cycles	MIL-STD-202, Method 107, Condition A-3, except +100°C
Mechanical Shock	1.5Kg, 0.5 ms, 5 shock pulses, Y1 direction only	MIL-STD-883, Method 2002, Condition B, except Y1 direction only
Vibration (Variable Frequency)	50g peak	MIL-STD-883, Method 2007, Condition B
Autoclave	15 psig, 100% RH, 121°C, 96 hours	JESD22-A102, Condition C
HAST	130°C, 85% RH, 96 hours	JESD22-A110
Solderability	10X Magnification	J-STD-002, Para 4.2.5, Test S, 95% Coverage
Solder Reflow Heat	Sn-Pb Eutetic Process: 240°C peak Pb-Free Process: 260°C peak	J-STD-020, Table 4-1, 4-2 and 5-2; Figure 5-1
Moisture Sensitivity: Level 1	Bake at 125°C for 24 hours Soak at 85°C/85% RH for 168 hours, Reflow 3 cycles at 260°C peak	J-STD-020
Marking Resistance to Solvents	Isopropyl alcohol + mineral spirits at 25°C; terpene defluxer at 25°C; distilled water + proylene glycol monomethyl ether +	MIL-STD-202, Method 215



All Mini-Circuits products are manufactured under exacting quality assurance and control standards, and are capable of meeting published specifications after being subjected to any or all of the following physical and environmental test.

Specification	Test/Inspection Condition	Reference/Spec
	monoethanolamine at 63°C to 70°C	