



FLEXIBLE

Coaxial Cable

FL086-12SMNM+

50Ω 12 inch DC to 18 GHz SMA Male to N-Type Male

THE BIG DEAL

- Wideband Frequency Coverage, DC to 18 GHz
- Low Insertion Loss, 0.7 dB Typ. at 18 GHz
- Excellent Return Loss, 25 dB Typ. at 18 GHz
- 6 mm Bend Radius for Tight Installations
- Insulated Outer Jacket Standard
- Connector Interface, Meets MIL-STD-348
- Ideal for Interconnect of Assembled Systems



Generic photo used for illustration purposes only

Model No.	FL086-12SMNM+
Case Style	SE2635-12
Connectors	SMA Male to N-Type Male

APPLICATIONS

- Replacement for Custom Bent 0.086" Semi-Rigid Cables
- Communication Receivers and Transmitters
- Military and Aerospace Systems
- Environmental and Test Chambers
- Test Accessory

+RoHS Compliant
 The +Suffix identifies RoHS Compliance.
 See our website for methodologies and qualifications

PRODUCT OVERVIEW

The FL086 Series Flexible Coaxial Cables are ideal for interconnection of coaxial components or sub-systems. The construction includes a silver-plated copper-clad steel center conductor. The outer shield is copper braid, silver-plated, which minimizes signal leakage and at the same time flexible for easy bend. Dielectric is low loss PTFE. SMA male connector have passivated stainless-steel coupling nut over a gold-plated body with a gold plated brass center conductor. N-Type male connector have brass coupling nut over a Nickel-plated body with a gold-plated brass center conductor. The FL086 Series Flexible cables are available in variety of length to meet your requirements.

KEY FEATURES

Feature	Advantages
Flexible RF Cables	The FL086 Series Flexible cables are ideal for use integrating coaxial components and sub-assemblies without the need for special cable-bending tools and alleviating the risk of damage during the bending process typical of semi-rigid coaxial cable assemblies.
Tight Bend Radius	Capable of only 6 mm bend radius, the FL086 Flexible series is able to make connections in tight spaces making these cables ideal for dense system integration
Excellent Return Loss <ul style="list-style-type: none"> • 28 dB typ. at 6 GHz • 25 dB typ. at 18 GHz 	The FL086 Series Flexible Cables are ideally suited for interconnecting a wide variety of RF components while minimizing VSWR ripple contribution due to mating cables & connectors.
Good Power Handling Capability <ul style="list-style-type: none"> • 198 W at 0.5 GHz • 33 W at 18 GHz 	Mini-Circuits FL086 Cable series can support medium to high RF power levels enabling these cables to be used in the transmit path. NOTE: power rating is at sea-level altitudes.





FLEXIBLE

Coaxial Cable

FL086-12SMNM+



50Ω 12 inch DC to 18 GHz SMA Male to N-Type Male

ELECTRICAL SPECIFICATIONS AT +25 °C

Parameter	Frequency (GHz)	Min.	Typ.	Max.	Units
Frequency Range		DC		18	GHz
Length ¹		12			inches
Insertion Loss	DC-2	-	0.2	0.6	dB
	2-6	-	0.4	1.0	
	6-10	-	0.6	1.3	
	10-18	-	0.7	1.7	
Return Loss	DC-2	23	43	-	dB
	2-6	23	40	-	
	6-10	18	28	-	
	10-18	18	25	-	

1. Custom sizes available, consult factory.

ABSOLUTE MAXIMUM RATINGS²

Parameter	Ratings
Operating Temperature	-55 °C to +105 °C
Storage Temperature	-55 °C to +105 °C
Power Handling at +25 °C, Sea Level	198 W at 0.5 GHz
	140 W at 1 GHz
	99 W at 2 GHz
	57 W at 6 GHz
	45 W at 10 GHz
	33 W at 18 GHz

2. Permanent damage may occur if any of these limits are exceeded.





FLEXIBLE

Coaxial Cable

FL086-12SMNM+

Mini-Circuits

50Ω 12 inch DC to 18 GHz SMA Male to N-Type Male

CABLE CONSTRUCTION

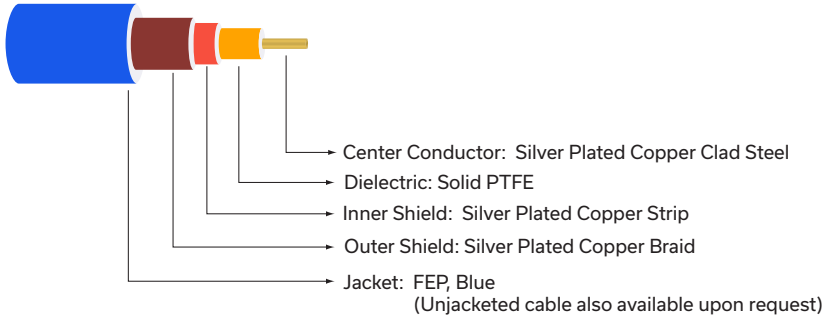

SMA-Male Connector:
 Coupling Nut: Stainless Steel Passivated
 Body: Stainless Steel Gold Plated
 Center Pin: Brass, Gold Plated

N-Male Connector:
 Coupling Nut: Brass, Nickel Plated
 Body: Brass, Nickel Plated
 Center Pin: Brass, Gold Plated

OUTLINE DRAWING

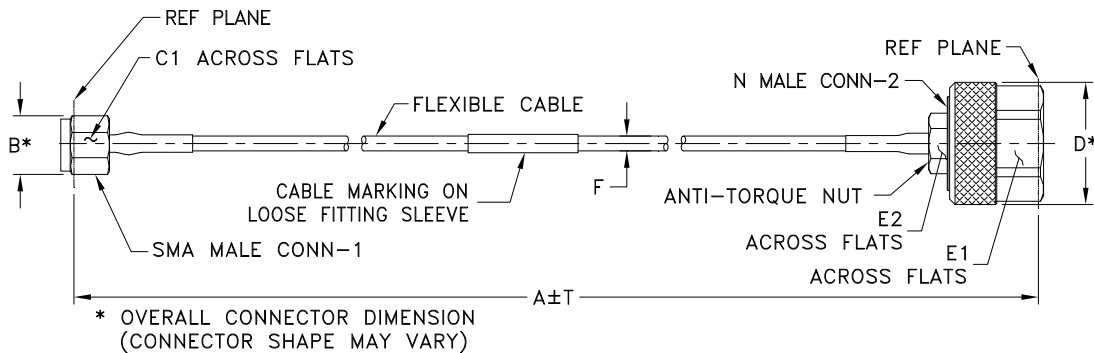

OUTLINE DIMENSIONS (Inch/mm)

A	B	C1	C2	D	E1	E2	T	wt
12.0	.36	.313	--	.88	.750	.375	0.1	grams
304.80	9.14	7.95	--	22	19.05	9.5	2.54	42.92





FLEXIBLE

Coaxial Cable

FL086-12SMNM+

Mini-Circuits

50Ω 12 inch DC to 18 GHz SMA Male to N-Type Male

TYPICAL PERFORMANCE DATA AND CHARTS

Frequency (MHz)	Insertion Loss (dB)	Return Loss (dB)	
		SMA Male	N-Type Male
100	0.07	43.5	45.9
1000	0.23	38.4	38.3
2000	0.33	45.5	45.9
2500	0.37	38.6	38.7
4000	0.48	36.7	31.5
5000	0.54	33.2	29.0
6000	0.59	26.9	25.7
7000	0.66	21.3	23.5
8000	0.67	23.3	24.9
9000	0.68	26.6	27.2
10000	0.67	24.6	22.5
12000	0.71	31.6	36.7
14000	0.80	30.9	26.9
17000	0.86	21.9	21.2
18000	0.95	21.8	22.4

FL086-12SMNM+ INSERTION LOSS

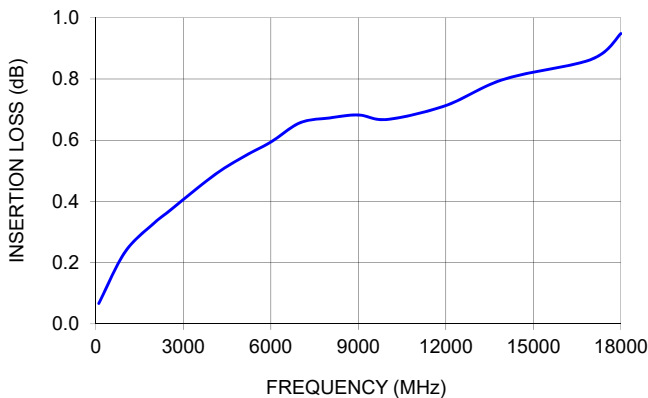

FL086-12SMNM+ RETURN LOSS

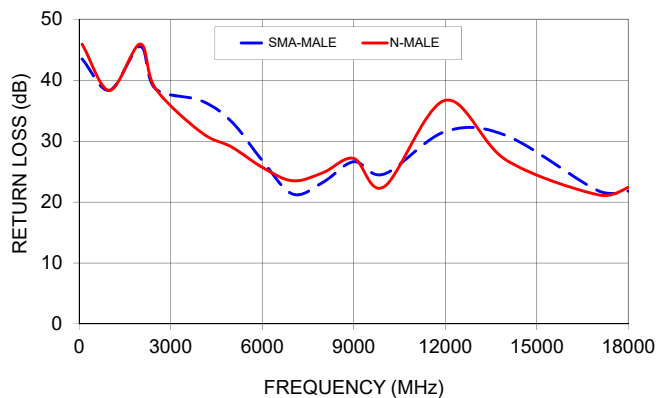

NOTES

- A. Performance and quality attributes and conditions not expressly stated in this specification document are intended to be excluded and do not form a part of this specification document.
- B. Electrical specifications and performance data contained in this specification document are based on Mini-Circuit's applicable established test performance criteria and measurement instructions.
- C. The parts covered by this specification document are subject to Mini-Circuits standard limited warranty and terms and conditions (collectively, "Standard Terms"); Purchasers of this part are entitled to the rights and benefits contained therein. For a full statement of the standard terms and the exclusive rights and remedies thereunder, please visit Mini-Circuits' website at www.minicircuits.com/terms/viewterm.html



Typical Performance Data

FREQUENCY (MHz)	INSERTION LOSS (dB)	SMA-MALE RETURN LOSS (dB)	N-MALE RETURN LOSS (dB)
100	0.07	43.5	45.9
200	0.10	39.6	40.4
300	0.14	40.1	39.5
400	0.16	43.3	47.0
500	0.17	46.7	42.5
600	0.19	40.2	39.1
700	0.20	40.6	41.2
800	0.22	45.3	49.7
900	0.23	41.9	40.2
1000	0.23	38.4	38.3
1100	0.25	41.1	42.6
1250	0.27	45.8	43.4
1500	0.29	48.4	54.8
1750	0.31	42.0	44.7
2000	0.33	45.5	45.9
2001	0.33	45.7	46.2
2250	0.34	44.4	43.9
2500	0.37	38.8	39.4
2750	0.39	38.2	38.9
3000	0.41	43.0	38.0
3250	0.42	32.7	30.0
3500	0.45	30.6	28.4
3750	0.47	40.6	43.2
4000	0.49	34.5	29.6
4250	0.51	29.5	26.1
4500	0.53	31.9	30.1
5000	0.55	32.3	28.2
5500	0.56	33.9	33.7
6000	0.59	26.9	25.7
6500	0.60	30.6	39.1
7000	0.64	21.0	23.2
7500	0.66	29.7	37.9
8000	0.67	23.5	24.7
8500	0.68	33.3	33.7
9000	0.66	26.9	28.0
9500	0.70	22.3	24.7
10000	0.67	24.6	22.5
10500	0.72	23.9	22.0
11000	0.74	25.0	24.1
11500	0.75	26.8	21.7
12000	0.75	30.8	35.9
12500	0.77	26.2	21.2
13000	0.80	36.7	49.7
13500	0.77	25.5	23.6
14000	0.80	33.2	26.1
14500	0.81	27.6	25.6
15000	0.82	32.6	24.9
15500	0.83	30.0	24.0
16000	0.80	30.0	48.4
16500	0.79	35.0	31.0
17000	0.90	21.9	21.7
17500	0.87	31.7	38.3
18000	0.95	21.8	22.4

Typical Performance Curves

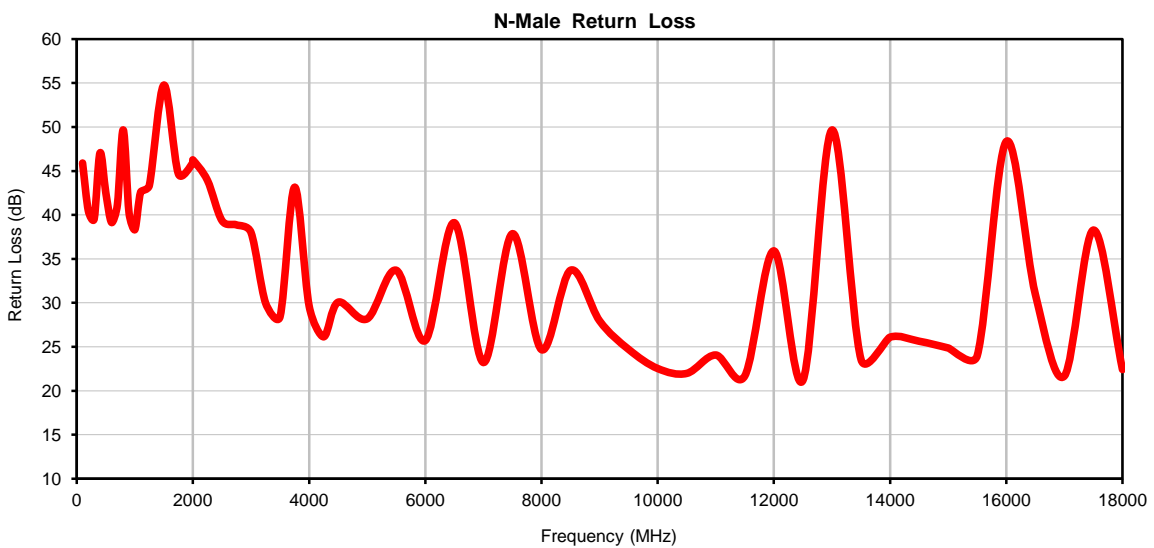
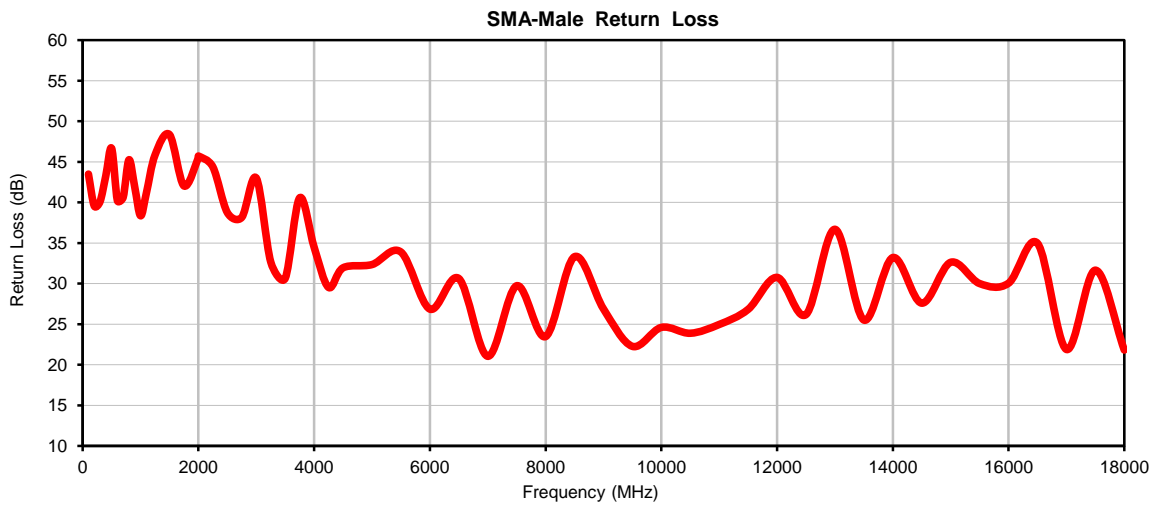
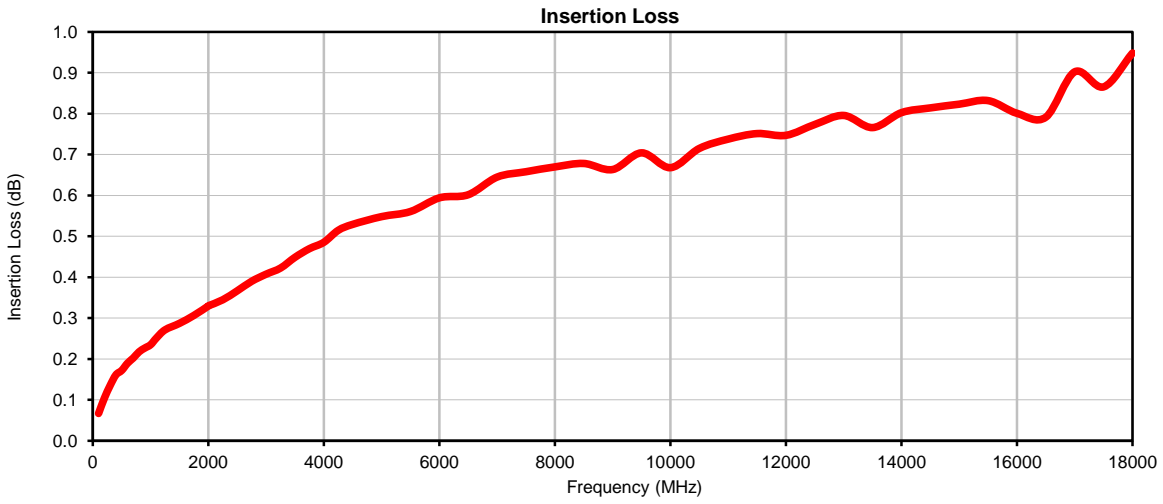

Outline Dimensions

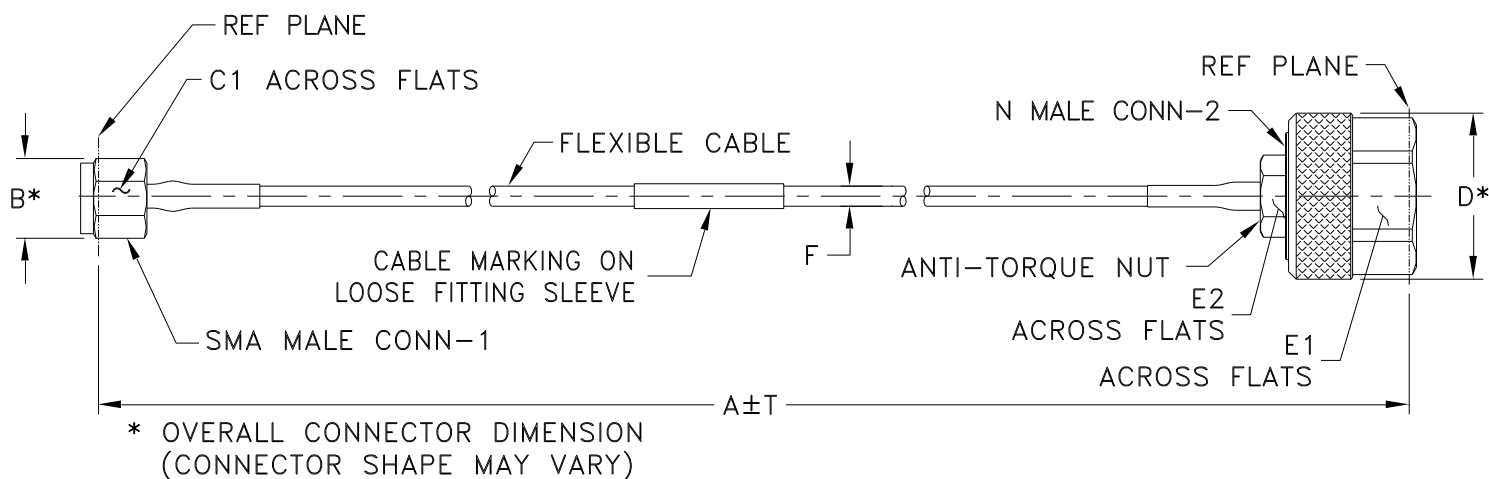

SE2635 SERIES
 SMA MALE (CONN-1)
 N MALE (CONN-2)

CASE STYLE #	A		B	C1	C2	D	E1	E2	F FL086-ASMNM+	T		WEIGHT GRAMS
	INCH	MM								INCH	MM	
SE2635-6	6	152.4	.36 (9.14)	.313 (7.95)	-	.88 (22.0)	.750 (19.0)	.375 (9.5)	.106±.004 (2.64±0.1)	0.05	1.27	40.01
SE2635-12	12	304.8								0.10	2.54	42.92
SE2635-24	24	609.6								0.15	3.81	48.74

Unless otherwise specified dimensions are in inches (mm).

Tolerances: 2Pl. ± .03; 3Pl. ± .015

Note:

- 086 Flexible Coaxial Cable.
- "A" Represents Length of Cable.



P.O. Box 350166, Brooklyn, New York 11235-0003 (718) 934-4500 Fax (718) 332-4661 For detailed performance specs & shopping online see Mini-Circuits web site



The Design Engineers Search Engine Provides ACTUAL Data Instantly From MINI-CIRCUITS At: www.minicircuits.com

RF/IF MICROWAVE COMPONENTS



All Mini-Circuits products are manufactured under exacting quality assurance and control standards, and are capable of meeting published specifications after being subjected to any or all of the following physical and environmental test.

Specification	Test/Inspection Condition	Reference/Spec
Operating Temperature	-55° to 105°C Ambient Environment	Individual Model Data Sheet
Storage Temperature	-55° to 105°C Ambient Environment	Individual Model Data Sheet
Thermal Shock	-55° to 105°C, 25 cycles	MIL-STD-202F: Method 107G
Multiple Bend Radius	40mm, 5 times for FL141 series cables 30 mm, 5 times for FL086 series cables	
Single Bend Radius	10 mm for FL141 series cables 6 mm for FL086 series cables	