

Surface Mount

Monolithic Amplifier

DC-5 GHz

Features

- Miniature SOT-89 Package
- Frequency range, DC to 5 GHz
- Internally Matched to 50 Ohms
- Output power, 17.6 dBm typ.
- Excellent package for heat dissipation, exposed metal bottom
- Aqueous washable
- Protected by US Patent 6,943,629

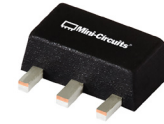

Generic photo used for illustration purposes only

Gali-59+

CASE STYLE: DF782

Applications

- Cellular
- PCS
- Communication receivers & transmitters

+RoHS Compliant

The +Suffix identifies RoHS Compliance. See our web site for RoHS Compliance methodologies and qualifications

General Description

Gali-59+ (RoHS compliant) is a wideband amplifier offering high dynamic range. Lead finish is SnAgNi. It has repeatable performance from lot to lot, and is enclosed in a SOT-89 package. It uses patented Transient Protected Darlington configuration and is fabricated using InGaP HBT technology. Gali-59+ is designed to be rugged for ESD and supply switch-on transients.

simplified schematic and pin description

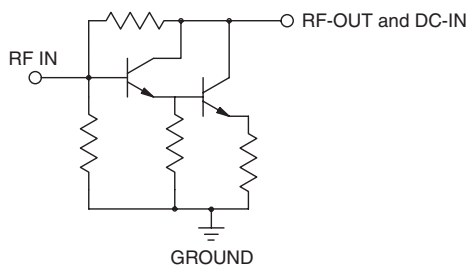

Function	Pin Number	Description
RF IN	1	RF input pin. This pin requires the use of an external DC blocking capacitor chosen for the frequency of operation.
RF-OUT and DC-IN	3	RF output and bias pin. DC voltage is present on this pin; therefore a DC blocking capacitor is necessary for proper operation. An RF choke is needed to feed DC bias without loss of RF signal due to the bias connection, as shown in "Recommended Application Circuit".
GND	2,4	Connections to ground. Use via holes as shown in "Suggested Layout for PCB Design" to reduce ground path inductance for best performance.

Notes

- Performance and quality attributes and conditions not expressly stated in this specification document are intended to be excluded and do not form a part of this specification document.
- Electrical specifications and performance data contained in this specification document are based on Mini-Circuit's applicable established test performance criteria and measurement instructions.
- The parts covered by this specification document are subject to Mini-Circuits standard limited warranty and terms and conditions (collectively, "Standard Terms"); Purchasers of this part are entitled to the rights and benefits contained therein. For a full statement of the Standard Terms and the exclusive rights and remedies thereunder, please visit Mini-Circuits' website at www.minicircuits.com/MCLStore/terms.jsp



Electrical Specifications at 25°C and 65mA, unless noted

Parameter	Min.	Typ.	Max.	Units
Frequency Range*	DC		5	GHz
Gain	f=0.1 GHz	—	20.6	GHz
	f=1 GHz	—	19.7	
	f=2 GHz	16.3	18.3	
	f=3 GHz	—	16.7	
	f=4 GHz	—	15.4	
	f=5 GHz	—	14.0	
	f=7 GHz	—	10.2	
Input Return Loss	f= DC to 3 GHz		12.5	dB
	f= 3 to 5 GHz		14	
Output Return Loss	f= DC to 3 GHz		14	dB
	f= 3 to 5 GHz		11.5	
Output Power @ 1 dB compression	f=2 GHz	16.5	17.6	dBm
Output IP3	f=1 GHz		33.3	dBm
Noise Figure	f=2 GHz		4.3	dB
Recommended Device Operating Current		65		mA
Device Operating Voltage	4.3	4.8	5.2	V
Device Voltage Variation vs. Temperature at 65 mA		-3.1		mV/°C
Device Voltage Variation vs. Current at 25°C		6.2		mV/mA
Thermal Resistance, junction-to-case ¹		103		°C/W

*Guaranteed specification DC-5 GHz. Low frequency cut off determined by external coupling capacitors.

Absolute Maximum Ratings

Parameter	Ratings
Operating Temperature*	-45°C to 85°C
Storage Temperature	-65°C to 150°C
Operating Current	85mA
Input Power	13dBm

Note: Permanent damage may occur if any of these limits are exceeded.

These ratings are not intended for continuous normal operation.

¹Case is defined as ground leads.

*Based on typical case temperature rise 5°C above ambient.

Notes

- A. Performance and quality attributes and conditions not expressly stated in this specification document are intended to be excluded and do not form a part of this specification document.
- B. Electrical specifications and performance data contained in this specification document are based on Mini-Circuit's applicable established test performance criteria and measurement instructions.
- C. The parts covered by this specification document are subject to Mini-Circuits standard limited warranty and terms and conditions (collectively, "Standard Terms"); Purchasers of this part are entitled to the rights and benefits contained therein. For a full statement of the Standard Terms and the exclusive rights and remedies thereunder, please visit Mini-Circuits' website at www.minicircuits.com/MCLStore/terms.jsp



Product Marking

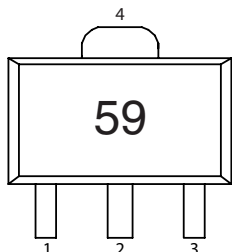

Markings in addition to model number designation may appear for internal quality control purposes.

Additional Detailed Technical Information

Additional information is available on our web site. To access this information enter the model number on our web site home page.

Performance data, graphs, s-parameter data set (.zip file)

Case Style: DF782

Plastic package, exposed paddle, lead finish: Matte-Tin

Tape & Reel: F55

7" reels with 20, 50, 100, 200, 500, 1K devices.

Suggested Layout for PCB Design: PL-019

Evaluation Board: TB-409-59+

Environmental Ratings: ENV08T2

Recommended Application Circuit

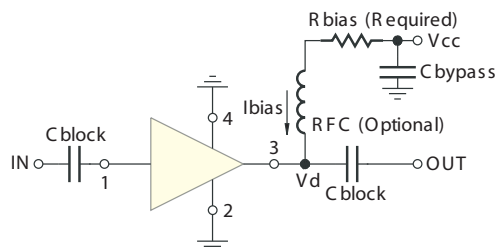

Test Board includes case, connectors, and components (in bold) soldered to PCB

R BIAS	
Vcc	"1%" Res. Values (ohms) for Optimum Biasing
7	36.5
8	51.1
9	64.9
10	80.6
11	97.6
12	113
13	127
14	143
15	158
16	174
17	191
18	205
19	221
20	237

Notes

- A. Performance and quality attributes and conditions not expressly stated in this specification document are intended to be excluded and do not form a part of this specification document.
- B. Electrical specifications and performance data contained in this specification document are based on Mini-Circuit's applicable established test performance criteria and measurement instructions.
- C. The parts covered by this specification document are subject to Mini-Circuits standard limited warranty and terms and conditions (collectively, "Standard Terms"); Purchasers of this part are entitled to the rights and benefits contained therein. For a full statement of the Standard Terms and the exclusive rights and remedies thereunder, please visit Mini-Circuits' website at www.minicircuits.com/MCLStore/terms.jsp



ESD Rating

Human Body Model (HBM): Class 1B (500V to < 1000V) in accordance with ANSI/ESD STM 5.1 - 2001

Machine Model (MM): Class M1 (< 100V) in accordance with ANSI/ESD STM 5.2 - 1999

MSL Rating

Moisture Sensitivity: MSL1 in accordance with IPC/JEDECJ-STD-020C

No.	Test Required	Condition	Standard	Quantity
1	Visual Inspection	Low Power Microscope Magnification 40x	MIP-IN-0003 (MCT spec)	45 units
2	Electrical Test	Room Temperature	SCD (MCL spec)	45 units
3	SAM Analysis	Less than 10% growth in term of delamination	J-Std-020C (Jedec Standard)	45 units
4	Moisture Sensitivity Level 1	Bake at 125°C for 24 hours Soak at 85°C/85%RH for 168 hours Reflow 3 cycles at 260°C peak	J-Std-020C (Jedec Standard)	45 units

MSL Test Flow Chart

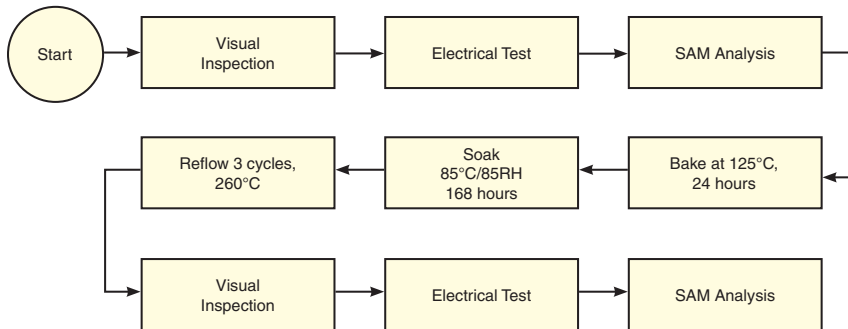

Notes

- A. Performance and quality attributes and conditions not expressly stated in this specification document are intended to be excluded and do not form a part of this specification document.
- B. Electrical specifications and performance data contained in this specification document are based on Mini-Circuit's applicable established test performance criteria and measurement instructions.
- C. The parts covered by this specification document are subject to Mini-Circuits standard limited warranty and terms and conditions (collectively, "Standard Terms"); Purchasers of this part are entitled to the rights and benefits contained therein. For a full statement of the Standard Terms and the exclusive rights and remedies thereunder, please visit Mini-Circuits' website at www.minicircuits.com/MCLStore/terms.jsp



Typical Performance Data

**NOTE: Use PDF Bookmarks to view DATA at required conditions
or to view GRAPHS.**

Definitions:

Input Return Loss = -S11 (dB)

Gain(Power Gain) = S21 (dB)

Reverse Isolation = -S12 (dB)

Output Return Loss = -S22 (dB)

TEST CONDITIONS: Icc = 65mA, Vd = 4.83V @Temperature = +25degC

FREQ	Gain	Isolation	Input Return Loss	Output Return Loss	Stability		FREQ	IP3 Output	1dB Comp. Output	Noise Figure
(MHz)	(dB)	(dB)	(dB)	(dB)	K	Delta	(MHz)	(dBm)	(dBm)	(dB)
50	20.87	24.09	23.70	38.54	1.07	0.69	50	35.12	18.41	2.88
100	20.83	24.06	23.79	36.64	1.07	0.69	100	34.82	18.43	3.07
200	20.76	24.17	24.27	33.77	1.08	0.68	200	34.89	18.34	2.93
400	20.59	24.19	24.01	28.76	1.08	0.66	300	34.82	18.29	3.16
600	20.39	24.14	23.82	25.68	1.09	0.65	400	34.24	18.33	3.09
800	20.14	24.14	23.41	23.33	1.10	0.63	500	33.74	18.21	3.08
1000	19.87	24.09	22.98	21.64	1.11	0.61	600	33.56	18.13	3.06
1200	19.56	24.09	22.25	20.34	1.12	0.59	700	33.53	18.13	3.06
1400	19.26	24.05	21.37	19.12	1.13	0.57	800	33.44	18.08	3.10
1600	18.93	24.03	20.61	18.17	1.15	0.54	900	33.35	17.94	3.05
1800	18.60	24.00	19.69	17.37	1.16	0.52	1000	33.11	17.98	3.10
2000	18.28	23.96	18.83	16.72	1.17	0.50	1100	32.85	17.91	3.01
2200	17.95	23.94	18.09	16.15	1.19	0.48	1200	32.58	17.74	3.05
2400	17.62	23.91	17.27	15.65	1.21	0.46	1300	32.26	17.75	3.03
2600	17.32	23.90	16.52	15.24	1.22	0.44	1400	31.91	17.66	3.17
2800	17.00	23.87	15.85	14.94	1.24	0.42	1500	31.67	17.60	3.23
3000	16.74	23.85	15.17	14.60	1.25	0.41	1600	31.83	17.56	3.18
3200	16.47	23.78	14.54	14.37	1.26	0.40	1700	32.00	17.47	3.19
3400	16.24	23.75	13.97	14.10	1.27	0.38	1800	31.74	17.43	3.25
3600	16.00	23.74	13.67	14.14	1.29	0.37	1900	31.33	17.36	3.18
3800	15.81	23.61	13.18	13.98	1.28	0.37	2000	31.16	17.31	3.11
4000	15.64	23.60	12.90	14.04	1.30	0.36	2100	30.93	17.21	3.21
4200	15.44	23.42	12.76	13.90	1.29	0.36	2200	30.56	16.97	3.13
4400	15.31	23.40	12.72	13.96	1.31	0.35	2300	30.22	16.78	3.14
4600	15.21	23.37	12.56	13.98	1.31	0.35	2400	29.92	16.59	3.21
5000	14.96	23.21	12.83	14.19	1.33	0.34	2500	29.76	16.42	3.10
5500	14.75	22.94	12.98	14.11	1.32	0.35	2600	29.57	16.21	3.23
6000	14.65	22.76	12.69	13.84	1.31	0.35	2700	29.46	16.15	3.20
6500	14.44	22.43	12.09	13.10	1.29	0.37	2800	29.35	15.95	3.18
7000	13.82	22.42	10.68	11.43	1.33	0.38	3000	28.97	15.79	3.09
7500	12.54	22.21	9.57	10.03	1.42	0.37	3200	28.20	15.17	3.23
8000	10.79	21.85	8.86	9.09	1.58	0.37	3400	27.70	14.91	3.27
9000	6.79	19.87	7.41	7.67	1.78	0.38	3600	27.32	14.60	3.36
10000	3.43	17.49	6.33	6.81	1.78	0.38	3800	26.86	14.06	3.44
11000	1.63	14.16	6.40	7.06	1.48	0.36	4000	26.30	13.60	3.27
12000	0.82	10.90	8.39	8.94	1.32	0.31	4200	25.89	13.00	3.30
13000	0.50	7.02	12.32	13.46	1.14	0.42	4400	25.49	12.63	3.45
14000	-0.11	4.17	12.30	15.07	1.05	0.61	4600	25.15	12.23	3.72
15000	-2.52	4.39	5.27	5.81	1.03	0.70	4800	24.80	11.81	3.82
16000	-5.12	5.90	3.85	3.83	1.12	0.68	5000	24.44	11.47	3.73

REV. X1

GALI-59+

120123

Page 1 of 11



IF/RF MICROWAVE COMPONENTS • ISO 9001 ISO 14001 AS 9100 CERTIFIED • RoHS compliant

P.O. Box 350166, Brooklyn, New York 11235-0003 (718) 934-4500 Fax (718) 332-4661



The Design Engineers Search Engine finds the model you need, Instantly • For detailed performance specs & shopping online see



Typical Performance Data

Definitions:

Input Return Loss = -S11 (dB)

Gain(Power Gain) = S21 (dB)

Reverse Isolation = -S12 (dB)

Output Return Loss = -S22 (dB)

TEST CONDITIONS: Icc = 52mA, Vd = 4.75V @Temperature = +25degC

FREQ	Gain	Isolation	Input Return Loss	Output Return Loss	Stability		FREQ	IP3 Output	1dB Comp. Output	Noise Figure
					K	Delta				
(MHz)	(dB)	(dB)	(dB)	(dB)	K	Delta	(MHz)	(dBm)	(dBm)	(dB)
50	20.66	24.14	21.54	30.30	1.08	0.67	50	31.80	16.69	2.82
100	20.62	23.94	21.67	29.24	1.07	0.68	100	31.55	16.73	2.92
200	20.54	24.05	22.08	28.68	1.08	0.67	200	31.69	16.60	2.83
400	20.39	24.03	21.92	26.97	1.08	0.66	300	31.70	16.56	3.10
600	20.21	23.97	21.86	24.79	1.09	0.65	400	31.28	16.67	2.97
800	19.96	23.94	21.72	22.97	1.10	0.63	500	31.01	16.60	2.94
1000	19.69	23.91	21.35	21.46	1.10	0.61	600	30.97	16.53	2.95
1200	19.39	23.90	20.79	20.27	1.12	0.59	700	31.15	16.54	2.94
1400	19.09	23.86	20.13	19.11	1.13	0.57	800	31.19	16.57	3.00
1600	18.76	23.86	19.43	18.18	1.14	0.54	900	31.22	16.40	2.91
1800	18.44	23.81	18.64	17.40	1.15	0.52	1000	31.10	16.36	2.96
2000	18.11	23.77	17.83	16.72	1.17	0.50	1100	30.95	16.31	2.89
2200	17.79	23.80	17.20	16.18	1.19	0.48	1200	30.80	16.12	2.99
2400	17.47	23.74	16.46	15.67	1.20	0.46	1300	30.61	16.22	2.91
2600	17.16	23.73	15.73	15.25	1.21	0.44	1400	30.36	16.10	3.06
2800	16.85	23.72	15.13	14.96	1.23	0.42	1500	30.21	16.06	3.12
3000	16.60	23.67	14.50	14.62	1.24	0.41	1600	30.40	16.02	3.06
3200	16.33	23.64	13.92	14.40	1.25	0.39	1700	30.71	15.96	3.11
3400	16.09	23.58	13.36	14.14	1.26	0.38	1800	30.53	16.03	3.14
3600	15.84	23.61	13.08	14.16	1.28	0.37	1900	30.20	15.90	3.04
3800	15.65	23.49	12.66	14.03	1.28	0.36	2000	30.06	15.96	3.05
4000	15.47	23.45	12.35	14.08	1.29	0.36	2100	29.89	15.96	3.08
4200	15.28	23.31	12.23	13.99	1.29	0.35	2200	29.63	15.84	2.98
4400	15.14	23.29	12.19	14.09	1.30	0.35	2300	29.39	15.80	3.01
4600	15.04	23.25	12.05	14.12	1.31	0.34	2400	29.17	15.66	3.07
5000	14.78	23.10	12.32	14.45	1.33	0.34	2500	29.03	15.55	3.02
5500	14.55	22.88	12.45	14.59	1.33	0.34	2600	28.85	15.36	3.09
6000	14.41	22.71	12.20	14.51	1.33	0.34	2700	28.70	15.26	3.09
6500	14.18	22.38	11.68	13.89	1.31	0.36	2800	28.63	15.14	3.05
7000	13.51	22.35	10.40	12.14	1.36	0.37	3000	28.28	14.98	2.93
7500	12.23	22.15	9.39	10.66	1.46	0.36	3200	27.53	14.47	3.02
8000	10.50	21.79	8.74	9.60	1.62	0.36	3400	27.11	14.21	3.09
9000	6.57	19.83	7.34	8.02	1.82	0.37	3600	26.71	13.84	3.20
10000	3.26	17.51	6.29	7.06	1.82	0.37	3800	26.23	13.34	3.28
11000	1.49	14.20	6.35	7.28	1.51	0.35	4000	25.67	12.92	3.10
12000	0.68	10.97	8.28	9.13	1.34	0.30	4200	25.31	12.31	3.18
13000	0.39	7.08	12.14	13.49	1.15	0.41	4400	24.85	11.90	3.27
14000	-0.18	4.20	12.18	15.23	1.05	0.60	4600	24.49	11.51	3.56
15000	-2.58	4.41	5.24	5.86	1.04	0.70	4800	24.16	11.08	3.63
16000	-5.15	5.90	3.84	3.83	1.12	0.67	5000	23.81	10.80	3.57

REV. X1

GALI-59+

120123

Page 2 of 11



IF/RF MICROWAVE COMPONENTS • ISO 9001 ISO 14001 AS 9100 CERTIFIED • RoHS compliant

P.O. Box 350166, Brooklyn, New York 11235-0003 (718) 934-4500 Fax (718) 332-4661



The Design Engineers Search Engine finds the model you need, Instantly • For detailed performance specs & shopping online see



Typical Performance Data

Definitions:

Input Return Loss = -S11 (dB)

Gain(Power Gain) = S21 (dB)

Reverse Isolation = -S12 (dB)

Output Return Loss = -S22 (dB)

TEST CONDITIONS: Icc = 78mA, Vd = 4.91V @Temperature = +25degC

FREQ	Gain	Isolation	Input Return Loss	Output Return Loss	Stability		FREQ	IP3 Output	1dB Comp. Output	Noise Figure
					K	Delta				
(MHz)	(dB)	(dB)	(dB)	(dB)	K	Delta	(MHz)	(dBm)	(dBm)	(dB)
50	21.01	24.05	25.35	50.78	1.06	0.70	50	37.77	19.39	2.96
100	20.95	24.20	25.47	43.54	1.07	0.69	100	37.42	19.43	3.13
200	20.88	24.29	25.86	35.80	1.08	0.68	200	37.22	19.31	2.99
400	20.72	24.27	25.56	29.11	1.08	0.66	300	36.89	19.30	3.27
600	20.52	24.26	25.36	25.65	1.09	0.65	400	36.12	19.28	3.16
800	20.26	24.23	24.81	23.26	1.10	0.63	500	35.31	19.07	3.16
1000	19.98	24.21	24.21	21.52	1.11	0.61	600	34.88	19.00	3.10
1200	19.68	24.22	23.31	20.22	1.12	0.59	700	34.63	18.91	3.13
1400	19.37	24.17	22.30	19.02	1.13	0.57	800	34.36	18.86	3.16
1600	19.04	24.13	21.42	18.07	1.15	0.55	900	34.09	18.65	3.13
1800	18.71	24.12	20.44	17.30	1.16	0.52	1000	33.75	18.73	3.13
2000	18.37	24.05	19.45	16.63	1.17	0.50	1100	33.46	18.66	3.09
2200	18.05	24.08	18.71	16.08	1.19	0.48	1200	33.09	18.46	3.13
2400	17.72	24.04	17.86	15.60	1.21	0.46	1300	32.69	18.42	3.11
2600	17.42	23.99	17.05	15.18	1.22	0.44	1400	32.32	18.29	3.25
2800	17.11	23.96	16.37	14.88	1.24	0.43	1500	32.06	18.24	3.29
3000	16.85	23.92	15.67	14.53	1.25	0.41	1600	32.15	18.16	3.25
3200	16.58	23.90	15.01	14.32	1.26	0.40	1700	32.17	18.01	3.27
3400	16.36	23.83	14.41	14.04	1.27	0.39	1800	31.85	18.00	3.35
3600	16.11	23.79	14.11	14.04	1.29	0.38	1900	31.48	17.89	3.24
3800	15.93	23.70	13.62	13.87	1.29	0.37	2000	31.31	17.82	3.19
4000	15.75	23.69	13.30	13.91	1.30	0.36	2100	31.09	17.70	3.27
4200	15.57	23.48	13.16	13.76	1.29	0.36	2200	30.69	17.43	3.21
4400	15.43	23.48	13.12	13.80	1.31	0.35	2300	30.35	17.20	3.19
4600	15.34	23.43	12.94	13.77	1.31	0.35	2400	30.03	17.00	3.29
5000	15.10	23.27	13.23	13.89	1.32	0.35	2500	29.91	16.87	3.19
5500	14.90	23.00	13.37	13.71	1.31	0.35	2600	29.70	16.67	3.31
6000	14.82	22.81	13.06	13.32	1.29	0.36	2700	29.56	16.58	3.28
6500	14.68	22.45	12.44	12.49	1.27	0.38	2800	29.45	16.47	3.27
7000	14.08	22.42	10.90	10.87	1.29	0.39	3000	29.10	16.26	3.19
7500	12.81	22.25	9.72	9.55	1.38	0.39	3200	28.32	15.65	3.27
8000	11.05	21.89	8.96	8.69	1.54	0.38	3400	27.85	15.41	3.35
9000	6.99	19.89	7.45	7.41	1.74	0.39	3600	27.48	15.09	3.47
10000	3.59	17.48	6.37	6.61	1.74	0.39	3800	27.05	14.57	3.55
11000	1.77	14.13	6.45	6.88	1.46	0.37	4000	26.48	14.09	3.37
12000	0.94	10.86	8.50	8.79	1.30	0.32	4200	26.13	13.55	3.43
13000	0.60	6.98	12.49	13.40	1.13	0.43	4400	25.75	13.19	3.55
14000	-0.04	4.15	12.41	14.91	1.04	0.61	4600	25.43	12.79	3.82
15000	-2.47	4.38	5.29	5.79	1.03	0.70	4800	25.08	12.32	3.90
16000	-5.09	5.89	3.85	3.81	1.12	0.68	5000	24.72	12.04	3.85

REV. X1
GALI-59+
120123
Page 3 of 11



IF/RF MICROWAVE COMPONENTS • ISO 9001 ISO 14001 AS 9100 CERTIFIED • RoHS compliant
P.O. Box 350166, Brooklyn, New York 11235-0003 (718) 934-4500 Fax (718) 332-4661



The Design Engineers Search Engine finds the model you need, Instantly • For detailed performance specs & shopping online see



Typical Performance Data

Definitions:

Input Return Loss = -S11 (dB)

Gain(Power Gain) = S21 (dB)

Reverse Isolation = -S12 (dB)

Output Return Loss = -S22 (dB)

TEST CONDITIONS: Icc = 65mA, Vd = 5.06V @Temperature = -45degC

FREQ	Gain	Isolation	Input Return Loss	Output Return Loss	Stability		FREQ	IP3 Output	1dB Comp. Output	Noise Figure
					K	Delta				
(MHz)	(dB)	(dB)	(dB)	(dB)	K	Delta	(MHz)	(dBm)	(dBm)	(dB)
50	21.01	24.16	23.56	39.73	1.06	0.70	50	35.70	18.65	2.34
100	20.97	24.24	22.79	34.36	1.07	0.69	100	35.45	18.72	2.51
200	20.89	24.31	23.21	32.70	1.08	0.68	200	35.53	18.57	2.41
400	20.75	24.21	24.56	29.40	1.08	0.67	300	35.63	18.57	2.67
600	20.57	24.20	24.62	25.87	1.08	0.66	400	35.13	18.65	2.56
800	20.34	24.18	23.96	23.38	1.09	0.64	500	34.66	18.57	2.51
1000	20.07	24.14	23.75	21.63	1.10	0.62	600	34.57	18.48	2.50
1200	19.77	24.10	22.84	20.41	1.11	0.60	700	34.60	18.47	2.48
1400	19.48	24.07	21.89	19.18	1.12	0.58	800	34.53	18.46	2.53
1600	19.16	24.02	20.86	18.36	1.13	0.56	900	34.44	18.33	2.44
1800	18.84	24.00	20.00	17.64	1.14	0.54	1000	34.21	18.35	2.50
2000	18.53	23.95	19.40	16.90	1.16	0.52	1100	34.02	18.27	2.39
2200	18.21	23.92	18.75	16.18	1.17	0.50	1200	33.78	18.15	2.44
2400	17.88	23.87	18.00	15.54	1.18	0.48	1300	33.49	18.18	2.44
2600	17.59	23.86	17.20	15.12	1.20	0.46	1400	33.13	18.09	2.57
2800	17.28	23.80	16.39	14.87	1.21	0.44	1500	32.93	18.06	2.60
3000	17.03	23.76	15.63	14.60	1.22	0.43	1600	33.07	18.03	2.54
3200	16.78	23.71	14.84	14.51	1.23	0.42	1700	33.25	17.98	2.57
3400	16.56	23.62	14.41	14.14	1.23	0.41	1800	33.02	17.93	2.65
3600	16.32	23.62	14.21	13.99	1.25	0.39	1900	32.69	17.91	2.53
3800	16.15	23.48	13.76	13.84	1.24	0.39	2000	32.54	17.89	2.51
4000	15.98	23.45	13.48	13.86	1.25	0.38	2100	32.32	17.85	2.56
4200	15.80	23.30	13.26	13.65	1.25	0.38	2200	31.94	17.66	2.50
4400	15.66	23.27	13.09	13.81	1.26	0.37	2300	31.66	17.48	2.49
4600	15.58	23.24	12.75	13.91	1.26	0.37	2400	31.32	17.30	2.53
5000	15.35	23.11	13.06	13.90	1.27	0.36	2500	31.07	17.12	2.46
5500	15.20	22.77	13.35	13.80	1.26	0.37	2600	30.83	16.91	2.57
6000	15.24	22.51	13.09	13.99	1.23	0.39	2700	30.71	16.85	2.56
6500	15.14	22.20	12.15	12.14	1.19	0.42	2800	30.63	16.70	2.50
7000	14.62	22.21	10.24	10.40	1.20	0.43	3000	30.34	16.54	2.46
7500	13.45	22.03	9.19	9.22	1.26	0.42	3200	29.60	15.97	2.52
8000	11.84	21.62	8.71	8.70	1.39	0.42	3400	29.10	15.72	2.55
9000	7.73	19.74	6.97	7.16	1.57	0.43	3600	28.76	15.38	2.62
10000	4.07	17.62	5.77	6.05	1.60	0.43	3800	28.28	14.90	2.70
11000	2.26	14.19	5.99	6.44	1.34	0.40	4000	27.70	14.58	2.54
12000	1.60	10.78	8.12	8.82	1.21	0.35	4200	27.37	14.02	2.61
13000	1.13	6.94	11.18	12.53	1.06	0.47	4400	26.97	13.60	2.69
14000	0.48	3.97	12.59	14.68	0.99	0.64	4600	26.68	13.18	2.93
15000	-1.67	3.77	5.18	5.74	0.97	0.78	4800	26.36	12.77	2.99
16000	-5.59	6.47	2.68	2.70	1.02	0.76	5000	26.01	12.44	2.98

REV. X1
GALI-59+
120123
Page 4 of 11



IF/RF MICROWAVE COMPONENTS • ISO 9001 ISO 14001 AS 9100 CERTIFIED • RoHS compliant
P.O. Box 350166, Brooklyn, New York 11235-0003 (718) 934-4500 Fax (718) 332-4661



The Design Engineers Search Engine finds the model you need, Instantly • For detailed performance specs & shopping online see



Typical Performance Data

Definitions:

Input Return Loss = -S11 (dB)

Gain(Power Gain) = S21 (dB)

Reverse Isolation = -S12 (dB)

Output Return Loss = -S22 (dB)

TEST CONDITIONS: Icc = 52mA, Vd = 4.97V @Temperature = -45degC

FREQ	Gain	Isolation	Input Return Loss	Output Return Loss	Stability		FREQ	IP3 Output	1dB Comp. Output	Noise Figure
					K	Delta				
(MHz)	(dB)	(dB)	(dB)	(dB)	K	Delta	(MHz)	(dBm)	(dBm)	(dB)
50	20.84	24.24	21.90	31.78	1.07	0.68	50	32.29	16.81	2.29
100	20.78	24.25	21.15	29.05	1.08	0.67	100	32.00	16.91	2.45
200	20.71	24.14	21.52	28.33	1.08	0.68	200	32.15	16.62	2.38
400	20.57	24.09	22.64	28.44	1.08	0.67	300	32.33	16.66	2.61
600	20.40	24.04	22.66	25.55	1.08	0.66	400	31.98	16.76	2.51
800	20.18	24.02	22.31	23.32	1.09	0.64	500	31.72	16.75	2.44
1000	19.91	23.95	22.18	21.66	1.10	0.62	600	31.75	16.67	2.46
1200	19.62	23.96	21.55	20.51	1.11	0.60	700	31.93	16.71	2.42
1400	19.33	23.89	20.73	19.28	1.11	0.58	800	32.01	16.71	2.48
1600	19.00	23.89	19.81	18.43	1.13	0.56	900	32.03	16.59	2.39
1800	18.70	23.85	19.01	17.71	1.14	0.54	1000	31.93	16.51	2.47
2000	18.38	23.77	18.50	16.97	1.15	0.52	1100	31.81	16.41	2.34
2200	18.07	23.76	17.95	16.26	1.17	0.50	1200	31.72	16.27	2.42
2400	17.75	23.71	17.20	15.60	1.18	0.48	1300	31.56	16.36	2.39
2600	17.45	23.69	16.47	15.18	1.19	0.46	1400	31.36	16.28	2.51
2800	17.15	23.68	15.71	14.90	1.21	0.44	1500	31.24	16.19	2.55
3000	16.90	23.62	14.94	14.62	1.21	0.43	1600	31.42	16.20	2.52
3200	16.64	23.57	14.25	14.53	1.22	0.42	1700	31.72	16.16	2.52
3400	16.43	23.49	13.82	14.19	1.22	0.40	1800	31.55	16.20	2.59
3600	16.18	23.50	13.64	14.04	1.24	0.39	1900	31.32	16.14	2.49
3800	16.01	23.38	13.21	13.90	1.24	0.39	2000	31.21	16.18	2.46
4000	15.84	23.36	12.95	13.94	1.25	0.38	2100	31.09	16.26	2.49
4200	15.65	23.19	12.74	13.75	1.24	0.37	2200	30.87	16.18	2.43
4400	15.52	23.18	12.56	13.94	1.26	0.37	2300	30.64	16.23	2.43
4600	15.42	23.16	12.27	14.08	1.26	0.36	2400	30.41	16.16	2.47
5000	15.18	23.03	12.57	14.14	1.28	0.36	2500	30.21	16.08	2.40
5500	15.02	22.68	12.82	14.18	1.26	0.37	2600	29.99	15.88	2.51
6000	15.03	22.48	12.57	14.56	1.25	0.38	2700	29.84	15.82	2.49
6500	14.89	22.15	11.71	12.78	1.21	0.41	2800	29.77	15.69	2.45
7000	14.33	22.14	9.97	11.02	1.22	0.42	3000	29.54	15.65	2.38
7500	13.15	22.00	9.00	9.77	1.30	0.41	3200	28.83	15.14	2.40
8000	11.54	21.57	8.58	9.18	1.43	0.40	3400	28.41	14.95	2.48
9000	7.49	19.73	6.90	7.47	1.62	0.42	3600	28.03	14.65	2.56
10000	3.90	17.64	5.74	6.28	1.64	0.42	3800	27.53	14.20	2.62
11000	2.11	14.23	5.93	6.65	1.36	0.38	4000	27.03	13.84	2.46
12000	1.46	10.85	8.01	9.01	1.23	0.34	4200	26.74	13.25	2.52
13000	1.01	6.99	11.02	12.64	1.07	0.46	4400	26.26	12.87	2.62
14000	0.39	4.00	12.49	14.80	0.99	0.63	4600	25.94	12.49	2.86
15000	-1.74	3.80	5.14	5.78	0.98	0.78	4800	25.57	12.02	2.93
16000	-5.62	6.48	2.68	2.72	1.02	0.76	5000	25.24	11.70	2.89

REV. X1
GALI-59+
120123
Page 5 of 11



IF/RF MICROWAVE COMPONENTS • ISO 9001 ISO 14001 AS 9100 CERTIFIED • RoHS compliant
P.O. Box 350166, Brooklyn, New York 11235-0003 (718) 934-4500 Fax (718) 332-4661



The Design Engineers Search Engine finds the model you need, Instantly • For detailed performance specs & shopping online see



Typical Performance Data

Definitions:

Input Return Loss = -S11 (dB)

Gain(Power Gain) = S21 (dB)

Reverse Isolation = -S12 (dB)

Output Return Loss = -S22 (dB)

TEST CONDITIONS: Icc = 78mA, Vd = 5.13V @Temperature = -45degC

FREQ	Gain	Isolation	Input Return Loss	Output Return Loss	Stability		FREQ	IP3 Output	1dB Comp. Output	Noise Figure
					K	Delta				
(MHz)	(dB)	(dB)	(dB)	(dB)	K	Delta	(MHz)	(dBm)	(dBm)	(dB)
50	21.12	24.45	25.14	49.16	1.07	0.68	50	38.24	19.78	2.39
100	21.08	24.36	24.12	39.53	1.07	0.69	100	37.95	19.85	2.57
200	21.01	24.36	24.39	35.71	1.07	0.68	200	38.00	19.70	2.44
400	20.87	24.36	26.13	29.04	1.08	0.67	300	37.78	19.71	2.71
600	20.69	24.30	25.97	25.54	1.08	0.66	400	37.12	19.71	2.58
800	20.44	24.28	25.23	23.13	1.09	0.64	500	36.34	19.60	2.54
1000	20.18	24.24	24.86	21.43	1.10	0.62	600	36.08	19.49	2.53
1200	19.88	24.21	23.83	20.23	1.11	0.60	700	35.87	19.44	2.55
1400	19.58	24.16	22.73	18.99	1.12	0.58	800	35.64	19.41	2.59
1600	19.25	24.12	21.59	18.22	1.13	0.56	900	35.42	19.25	2.50
1800	18.93	24.11	20.65	17.52	1.15	0.54	1000	35.13	19.32	2.54
2000	18.62	24.02	19.97	16.78	1.16	0.52	1100	34.85	19.23	2.47
2200	18.30	24.00	19.36	16.06	1.17	0.50	1200	34.55	19.09	2.50
2400	17.98	23.98	18.56	15.45	1.19	0.48	1300	34.15	19.07	2.48
2600	17.68	23.95	17.72	15.03	1.20	0.46	1400	33.76	18.96	2.62
2800	17.38	23.89	16.89	14.78	1.21	0.45	1500	33.53	18.93	2.64
3000	17.12	23.83	16.09	14.52	1.22	0.43	1600	33.58	18.86	2.61
3200	16.88	23.77	15.32	14.42	1.23	0.42	1700	33.64	18.75	2.62
3400	16.66	23.71	14.83	14.05	1.23	0.41	1800	33.40	18.70	2.71
3600	16.42	23.73	14.64	13.89	1.25	0.39	1900	33.06	18.63	2.59
3800	16.25	23.55	14.21	13.72	1.24	0.39	2000	32.94	18.58	2.57
4000	16.08	23.52	13.89	13.74	1.25	0.38	2100	32.71	18.46	2.60
4200	15.91	23.36	13.69	13.50	1.25	0.38	2200	32.28	18.19	2.55
4400	15.77	23.35	13.50	13.65	1.26	0.37	2300	31.95	17.97	2.55
4600	15.69	23.32	13.16	13.71	1.26	0.37	2400	31.59	17.75	2.60
5000	15.47	23.18	13.47	13.65	1.27	0.37	2500	31.37	17.64	2.51
5500	15.34	22.83	13.76	13.44	1.25	0.38	2600	31.15	17.41	2.61
6000	15.41	22.56	13.52	13.49	1.22	0.40	2700	31.03	17.35	2.62
6500	15.34	22.23	12.54	11.61	1.17	0.43	2800	30.94	17.23	2.58
7000	14.87	22.21	10.50	9.92	1.17	0.44	3000	30.63	17.07	2.51
7500	13.73	22.04	9.34	8.78	1.22	0.44	3200	29.90	16.52	2.59
8000	12.12	21.65	8.82	8.31	1.35	0.43	3400	29.41	16.26	2.62
9000	7.95	19.75	7.01	6.91	1.54	0.44	3600	29.10	15.98	2.69
10000	4.24	17.62	5.81	5.85	1.57	0.44	3800	28.59	15.51	2.76
11000	2.42	14.16	6.03	6.27	1.31	0.41	4000	28.05	15.19	2.66
12000	1.73	10.74	8.23	8.66	1.19	0.36	4200	27.75	14.62	2.70
13000	1.23	6.91	11.36	12.43	1.05	0.48	4400	27.35	14.21	2.77
14000	0.55	3.95	12.71	14.57	0.99	0.65	4600	27.08	13.79	3.02
15000	-1.61	3.76	5.20	5.71	0.97	0.79	4800	26.78	13.37	3.09
16000	-5.55	6.45	2.68	2.69	1.02	0.77	5000	26.45	13.07	3.08

REV. X1

GALI-59+

120123

Page 6 of 11



IF/RF MICROWAVE COMPONENTS • ISO 9001 ISO 14001 AS 9100 CERTIFIED • RoHS compliant

P.O. Box 350166, Brooklyn, New York 11235-0003 (718) 934-4500 Fax (718) 332-4661



The Design Engineers Search Engine finds the model you need, Instantly • For detailed performance specs & shopping online see



Typical Performance Data

Definitions:

Input Return Loss = -S11 (dB)

Gain(Power Gain) = S21 (dB)

Reverse Isolation = -S12 (dB)

Output Return Loss = -S22 (dB)

TEST CONDITIONS: Icc = 65mA, Vd = 4.64V @Temperature = +85degC

FREQ	Gain	Isolation	Input Return Loss	Output Return Loss	Stability		FREQ	IP3 Output	1dB Comp. Output	Noise Figure
					K	Delta				
(MHz)	(dB)	(dB)	(dB)	(dB)	K	Delta	(MHz)	(dBm)	(dBm)	(dB)
50	20.73	24.03	23.60	35.14	1.07	0.69	50	34.48	18.18	3.21
100	20.69	23.96	24.23	35.96	1.07	0.69	100	34.32	18.21	3.39
200	20.61	24.06	25.76	35.35	1.08	0.67	200	34.39	18.05	3.26
400	20.44	24.05	23.66	27.54	1.08	0.66	300	34.26	18.08	3.52
600	20.24	24.10	22.95	25.26	1.09	0.64	400	33.64	18.07	3.41
800	19.98	24.06	22.27	22.80	1.10	0.62	500	33.12	17.90	3.44
1000	19.69	24.05	21.61	21.46	1.11	0.60	600	32.91	17.82	3.40
1200	19.38	24.01	20.95	20.25	1.12	0.58	700	32.88	17.77	3.42
1400	19.07	23.99	20.25	19.12	1.14	0.56	800	32.77	17.73	3.46
1600	18.73	23.98	19.72	18.11	1.15	0.54	900	32.64	17.56	3.40
1800	18.40	23.97	19.03	17.27	1.17	0.51	1000	32.37	17.60	3.42
2000	18.06	23.96	18.25	16.56	1.19	0.49	1100	32.14	17.54	3.36
2200	17.72	23.94	17.48	15.93	1.20	0.47	1200	31.85	17.36	3.41
2400	17.38	23.88	16.64	15.45	1.22	0.45	1300	31.50	17.36	3.42
2600	17.06	23.90	15.81	15.08	1.24	0.43	1400	31.15	17.21	3.55
2800	16.74	23.83	15.08	14.79	1.25	0.41	1500	30.92	17.13	3.60
3000	16.46	23.85	14.41	14.55	1.27	0.39	1600	31.12	17.05	3.57
3200	16.18	23.83	13.75	14.29	1.28	0.38	1700	31.22	16.94	3.57
3400	15.93	23.77	13.20	14.12	1.29	0.37	1800	30.87	16.94	3.64
3600	15.66	23.74	12.92	14.21	1.31	0.36	1900	30.45	16.82	3.59
3800	15.47	23.64	12.49	14.11	1.31	0.35	2000	30.24	16.71	3.49
4000	15.26	23.64	12.37	14.20	1.34	0.34	2100	29.97	16.63	3.60
4200	15.07	23.45	12.29	13.98	1.33	0.34	2200	29.56	16.32	3.51
4400	14.91	23.43	12.43	14.07	1.35	0.33	2300	29.23	16.12	3.54
4600	14.79	23.41	12.45	14.21	1.37	0.33	2400	28.88	15.91	3.62
5000	14.51	23.26	12.68	14.44	1.39	0.32	2500	28.67	15.76	3.49
5500	14.23	23.06	12.42	14.62	1.39	0.32	2600	28.53	15.56	3.63
6000	14.02	22.98	12.07	14.49	1.40	0.31	2700	28.35	15.50	3.62
6500	13.68	22.61	11.94	14.24	1.41	0.33	2800	28.21	15.31	3.60
7000	12.89	22.60	11.17	12.70	1.49	0.33	3000	27.76	15.08	3.52
7500	11.51	22.33	10.07	11.02	1.62	0.33	3200	27.01	14.45	3.56
8000	9.71	21.92	9.11	9.77	1.79	0.33	3400	26.48	14.11	3.68
9000	5.75	19.88	7.54	8.02	1.99	0.34	3600	26.11	13.75	3.83
10000	2.66	17.44	6.71	7.39	1.97	0.34	3800	25.53	13.17	3.90
11000	1.01	14.02	6.90	7.80	1.63	0.32	4000	24.90	12.70	3.73
12000	0.03	10.96	8.36	8.98	1.43	0.29	4200	24.48	12.17	3.78
13000	-0.27	7.18	12.20	13.83	1.23	0.38	4400	24.03	11.82	3.93
14000	-0.63	4.35	12.77	16.44	1.11	0.57	4600	23.71	11.34	4.19
15000	-3.32	5.04	5.09	5.44	1.10	0.66	4800	23.36	10.90	4.31
16000	-5.15	5.82	4.58	4.55	1.19	0.61	5000	22.91	10.51	4.21

REV. X1

GALI-59+

120123

Page 7 of 11



IF/RF MICROWAVE COMPONENTS • ISO 9001 ISO 14001 AS 9100 CERTIFIED • RoHS compliant

P.O. Box 350166, Brooklyn, New York 11235-0003 (718) 934-4500 Fax (718) 332-4661



The Design Engineers Search Engine finds the model you need, Instantly • For detailed performance specs & shopping online see



Typical Performance Data

Definitions:

Input Return Loss = -S11 (dB)

Gain(Power Gain) = S21 (dB)

Reverse Isolation = -S12 (dB)

Output Return Loss = -S22 (dB)

TEST CONDITIONS: Icc = 52mA, Vd = 4.55V @Temperature = +85degC

FREQ	Gain	Isolation	Input Return Loss	Output Return Loss	Stability		FREQ	IP3 Output	1dB Comp. Output	Noise Figure
					K	Delta				
(MHz)	(dB)	(dB)	(dB)	(dB)	K	Delta	(MHz)	(dBm)	(dBm)	(dB)
50	20.49	23.92	21.27	27.46	1.08	0.68	50	31.34	16.63	3.18
100	20.45	23.91	21.68	28.51	1.08	0.67	100	31.18	16.68	3.34
200	20.38	23.88	22.94	29.64	1.08	0.67	200	31.38	16.56	3.22
400	20.22	23.88	21.62	25.34	1.08	0.66	300	31.31	16.53	3.45
600	20.02	23.90	21.03	23.86	1.09	0.64	400	30.83	16.62	3.39
800	19.76	23.88	20.49	21.99	1.10	0.62	500	30.54	16.46	3.36
1000	19.48	23.87	19.93	20.87	1.11	0.60	600	30.51	16.44	3.33
1200	19.18	23.85	19.48	19.83	1.12	0.58	700	30.64	16.39	3.37
1400	18.88	23.80	18.92	18.87	1.13	0.56	800	30.67	16.40	3.39
1600	18.55	23.76	18.58	17.96	1.15	0.54	900	30.69	16.28	3.33
1800	18.22	23.78	17.96	17.17	1.16	0.51	1000	30.55	16.21	3.37
2000	17.88	23.76	17.27	16.47	1.18	0.49	1100	30.37	16.15	3.32
2200	17.55	23.76	16.61	15.87	1.20	0.47	1200	30.24	15.99	3.37
2400	17.22	23.70	15.82	15.41	1.21	0.45	1300	30.03	16.03	3.34
2600	16.89	23.74	15.08	15.03	1.23	0.43	1400	29.75	15.93	3.49
2800	16.58	23.69	14.43	14.76	1.24	0.41	1500	29.63	15.87	3.53
3000	16.28	23.69	13.76	14.49	1.26	0.39	1600	29.85	15.86	3.49
3200	16.01	23.63	13.15	14.25	1.27	0.38	1700	30.14	15.78	3.49
3400	15.75	23.63	12.62	14.06	1.29	0.36	1800	29.88	15.78	3.58
3600	15.48	23.60	12.38	14.17	1.31	0.35	1900	29.54	15.71	3.52
3800	15.29	23.50	11.97	14.09	1.31	0.35	2000	29.37	15.69	3.43
4000	15.08	23.49	11.87	14.20	1.33	0.34	2100	29.17	15.64	3.54
4200	14.89	23.31	11.82	14.03	1.33	0.34	2200	28.87	15.44	3.43
4400	14.73	23.30	11.93	14.15	1.35	0.33	2300	28.60	15.34	3.46
4600	14.61	23.31	11.97	14.35	1.37	0.32	2400	28.36	15.16	3.55
5000	14.31	23.17	12.19	14.69	1.39	0.32	2500	28.13	15.00	3.42
5500	14.01	22.97	11.96	15.09	1.41	0.31	2600	27.96	14.84	3.54
6000	13.77	22.89	11.67	15.16	1.42	0.31	2700	27.82	14.70	3.54
6500	13.41	22.54	11.61	15.12	1.44	0.32	2800	27.57	14.55	3.50
7000	12.61	22.53	10.94	13.53	1.53	0.32	3000	27.30	14.35	3.44
7500	11.22	22.22	9.92	11.68	1.66	0.32	3200	26.49	13.79	3.59
8000	9.44	21.81	9.02	10.26	1.84	0.32	3400	26.05	13.41	3.58
9000	5.54	19.84	7.50	8.35	2.04	0.33	3600	25.56	13.05	3.74
10000	2.50	17.45	6.68	7.66	2.02	0.33	3800	25.10	12.48	3.80
11000	0.88	14.06	6.86	8.04	1.66	0.31	4000	24.48	12.07	3.63
12000	-0.10	11.04	8.28	9.17	1.46	0.28	4200	24.10	11.46	3.68
13000	-0.37	7.25	12.06	13.81	1.24	0.37	4400	23.59	11.15	3.82
14000	-0.70	4.38	12.64	16.62	1.11	0.56	4600	23.17	10.62	4.11
15000	-3.38	5.06	5.06	5.47	1.10	0.65	4800	22.85	10.18	4.19
16000	-5.18	5.82	4.57	4.58	1.20	0.61	5000	22.47	9.94	4.12

REV. X1
GALI-59+
120123
Page 8 of 11



IF/RF MICROWAVE COMPONENTS • ISO 9001 ISO 14001 AS 9100 CERTIFIED • RoHS compliant
P.O. Box 350166, Brooklyn, New York 11235-0003 (718) 934-4500 Fax (718) 332-4661



The Design Engineers Search Engine finds the model you need, Instantly • For detailed performance specs & shopping online see



Typical Performance Data

Definitions:

Input Return Loss = -S11 (dB)

Gain(Power Gain) = S21 (dB)

Reverse Isolation = -S12 (dB)

Output Return Loss = -S22 (dB)

TEST CONDITIONS: Icc = 78mA, Vd = 4.71V @Temperature = +85degC

FREQ	Gain	Isolation	Input Return Loss	Output Return Loss	Stability		FREQ	IP3 Output	1dB Comp. Output	Noise Figure
					K	Delta				
(MHz)	(dB)	(dB)	(dB)	(dB)	K	Delta	(MHz)	(dBm)	(dBm)	(dB)
50	20.87	24.07	25.12	48.09	1.07	0.69	50	37.12	18.91	3.29
100	20.82	24.11	26.14	46.78	1.07	0.69	100	36.93	19.08	3.48
200	20.75	24.20	27.95	35.75	1.08	0.67	200	36.74	18.89	3.29
400	20.58	24.18	25.51	28.23	1.08	0.66	300	36.26	18.77	3.59
600	20.36	24.18	24.49	25.71	1.09	0.64	400	35.52	18.67	3.47
800	20.10	24.20	23.61	23.10	1.10	0.62	500	34.66	18.65	3.52
1000	19.82	24.15	22.73	21.69	1.11	0.60	600	34.20	18.56	3.43
1200	19.51	24.18	21.92	20.38	1.13	0.58	700	33.90	18.45	3.50
1400	19.19	24.13	21.20	19.21	1.14	0.56	800	33.59	18.39	3.50
1600	18.85	24.12	20.58	18.15	1.16	0.53	900	33.32	18.15	3.48
1800	18.50	24.11	19.84	17.29	1.17	0.51	1000	32.95	18.23	3.47
2000	18.17	24.05	18.88	16.56	1.19	0.49	1100	32.61	18.14	3.45
2200	17.82	24.06	18.12	15.96	1.21	0.47	1200	32.28	17.92	3.49
2400	17.48	24.02	17.22	15.50	1.22	0.45	1300	31.84	17.89	3.48
2600	17.17	23.99	16.32	15.11	1.24	0.43	1400	31.48	17.75	3.62
2800	16.85	23.97	15.57	14.83	1.26	0.41	1500	31.24	17.64	3.67
3000	16.56	23.95	14.88	14.56	1.27	0.39	1600	31.33	17.59	3.65
3200	16.28	23.90	14.18	14.34	1.29	0.38	1700	31.20	17.40	3.64
3400	16.03	23.89	13.59	14.13	1.30	0.37	1800	30.80	17.35	3.72
3600	15.77	23.85	13.30	14.22	1.32	0.36	1900	30.45	17.24	3.65
3800	15.57	23.75	12.87	14.12	1.32	0.35	2000	30.24	17.15	3.58
4000	15.38	23.72	12.71	14.19	1.34	0.34	2100	29.97	17.05	3.68
4200	15.18	23.54	12.65	13.96	1.34	0.34	2200	29.57	16.74	3.59
4400	15.03	23.52	12.80	14.01	1.36	0.33	2300	29.21	16.50	3.60
4600	14.91	23.49	12.82	14.13	1.37	0.33	2400	28.88	16.28	3.70
5000	14.64	23.34	13.03	14.27	1.39	0.32	2500	28.67	16.13	3.58
5500	14.38	23.12	12.75	14.31	1.39	0.32	2600	28.44	15.94	3.72
6000	14.18	23.02	12.37	14.10	1.39	0.32	2700	28.25	15.85	3.70
6500	13.86	22.67	12.19	13.77	1.39	0.34	2800	28.08	15.71	3.70
7000	13.10	22.65	11.34	12.27	1.47	0.33	3000	27.67	15.47	3.60
7500	11.72	22.38	10.16	10.65	1.59	0.34	3200	26.89	14.87	3.64
8000	9.91	21.97	9.16	9.47	1.76	0.34	3400	26.44	14.52	3.77
9000	5.89	19.91	7.57	7.83	1.96	0.35	3600	25.97	14.20	3.93
10000	2.77	17.44	6.73	7.23	1.94	0.34	3800	25.43	13.63	4.01
11000	1.11	14.00	6.94	7.65	1.61	0.32	4000	24.86	13.17	3.83
12000	0.12	10.93	8.42	8.86	1.42	0.30	4200	24.50	12.64	3.87
13000	-0.20	7.14	12.31	13.81	1.22	0.38	4400	24.11	12.25	4.01
14000	-0.58	4.33	12.85	16.31	1.10	0.58	4600	23.73	11.80	4.29
15000	-3.29	5.03	5.09	5.41	1.09	0.66	4800	23.30	11.42	4.39
16000	-5.12	5.81	4.57	4.55	1.19	0.61	5000	22.89	11.03	4.32

REV. X1
GALI-59+
120123
Page 9 of 11



IF/RF MICROWAVE COMPONENTS • ISO 9001 ISO 14001 AS 9100 CERTIFIED • RoHS compliant
P.O. Box 350166, Brooklyn, New York 11235-0003 (718) 934-4500 Fax (718) 332-4661



The Design Engineers Search Engine finds the model you need, Instantly • For detailed performance specs & shopping online see



Typical Performance Curves

GAIN vs. TEMPERATURE

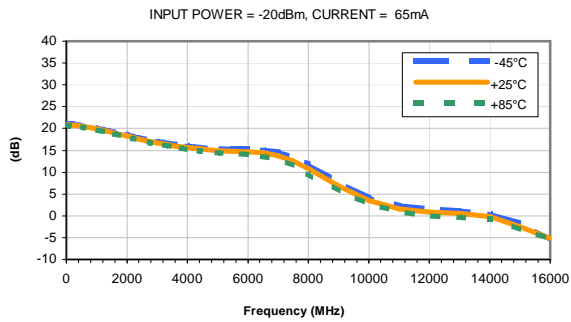

GAIN vs. CURRENT

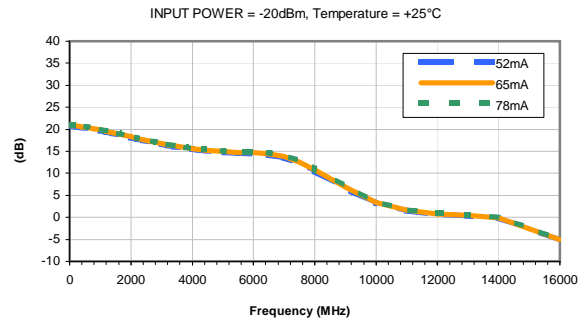

ISOLATION vs. TEMPERATURE

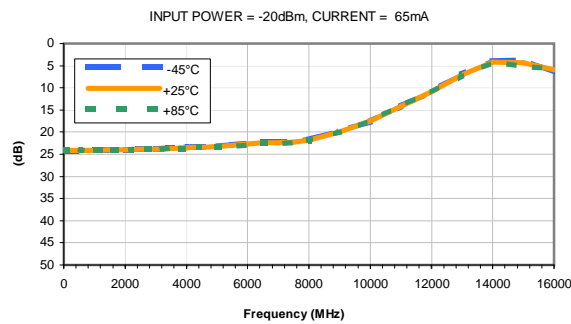

ISOLATION vs. CURRENT

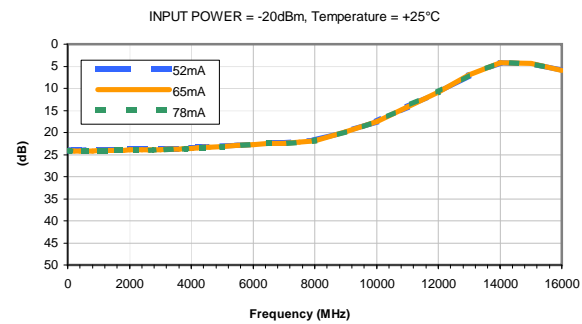

INPUT RETURN LOSS vs. TEMPERATURE

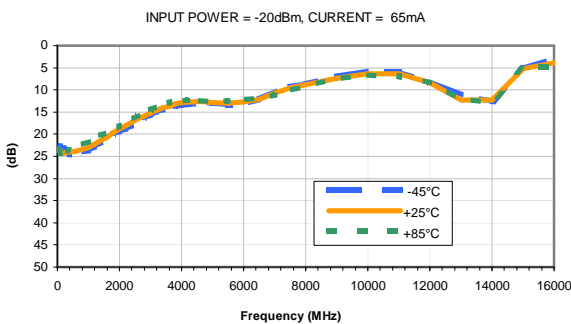

INPUT RETURN LOSS vs. CURRENT

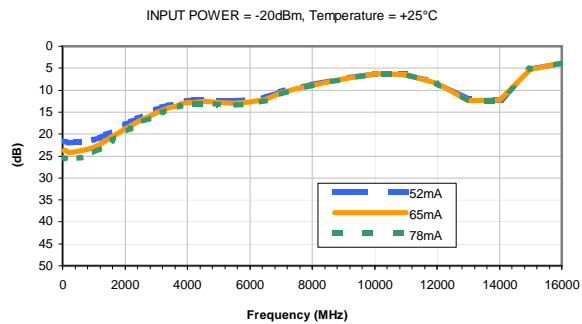

OUTPUT RETURN LOSS vs. TEMPERATURE

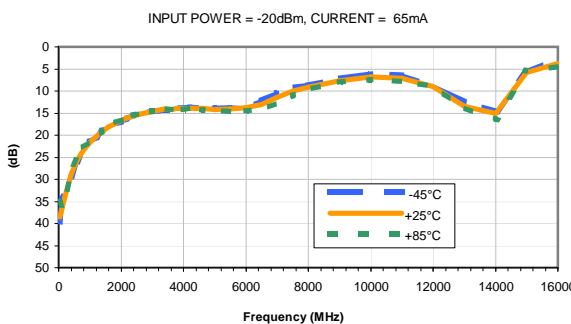

OUTPUT RETURN LOSS vs. CURRENT

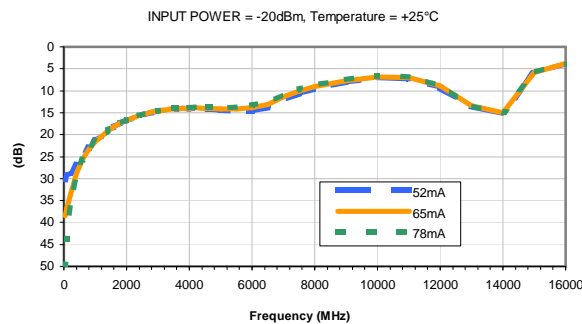

Typical Performance Curves

OUTPUT IP3 vs. TEMPERATURE

INPUT POWER = -20dBm, CURRENT = 65mA

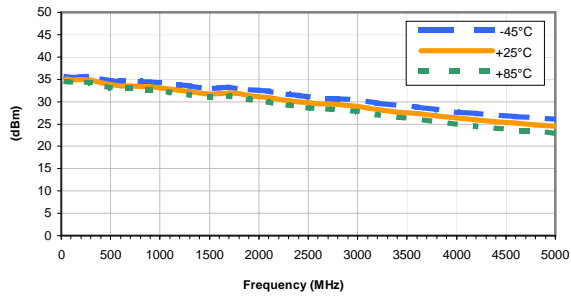

OUTPUT IP3 vs. CURRENT

INPUT POWER = -20dBm, Temperature = +25°C

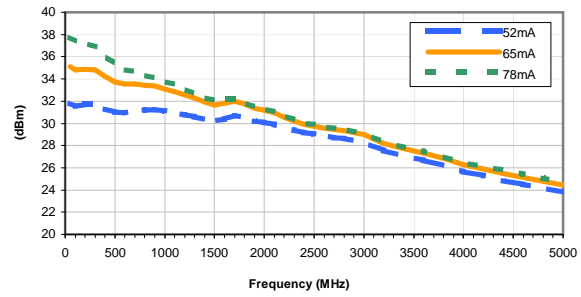

OUTPUT POWER at 1dB Compression vs. TEMPERATURE

CURRENT = 65mA

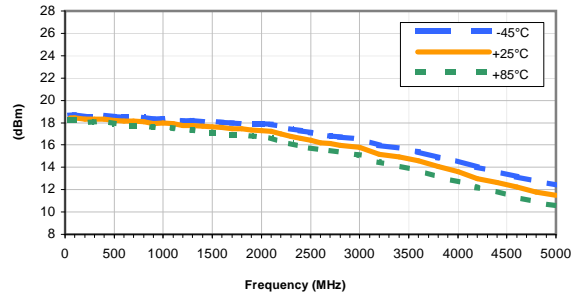

OUTPUT POWER at 1dB Compression vs. CURRENT

Temperature = +25°C

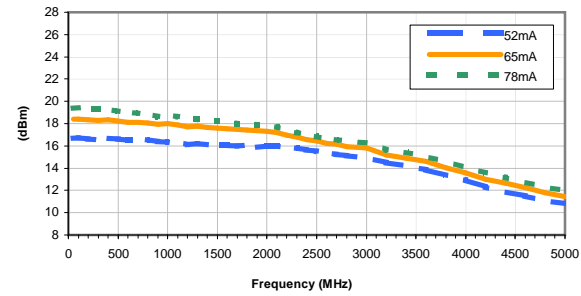

Noise Figure vs. TEMPERATURE

CURRENT = 65mA

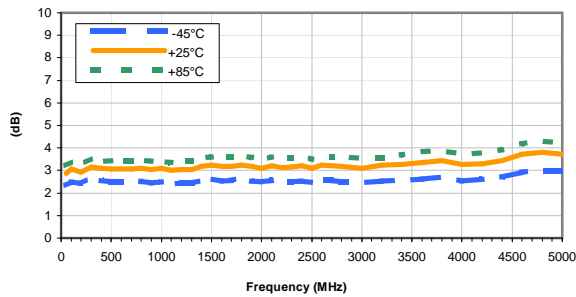

Noise Figure vs. CURRENT

Temperature = +25°C

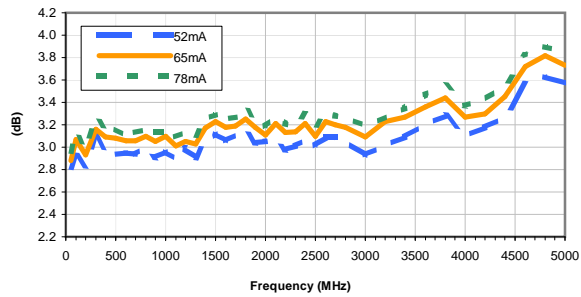

Typical Performance Curves

GAIN vs. TEMPERATURE

INPUT POWER = -20dBm, CURRENT = 65mA

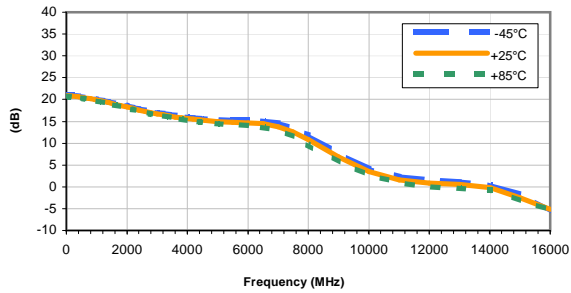

GAIN vs. CURRENT

INPUT POWER = -20dBm, Temperature = +25°C

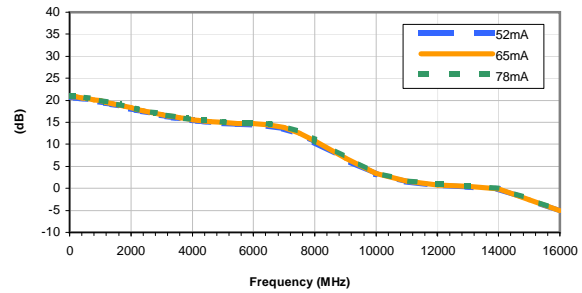

ISOLATION vs. TEMPERATURE

INPUT POWER = -20dBm, CURRENT = 65mA

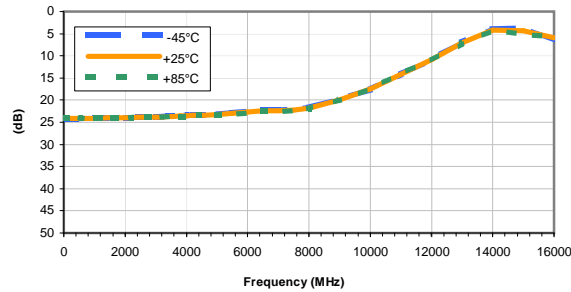

ISOLATION vs. CURRENT

INPUT POWER = -20dBm, Temperature = +25°C

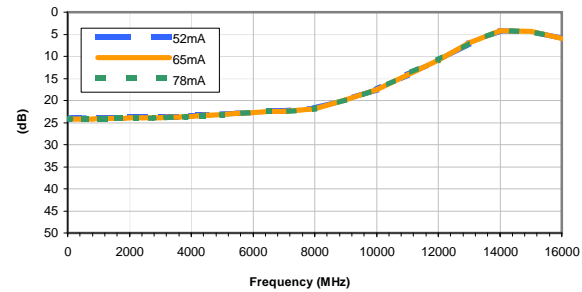

INPUT RETURN LOSS vs. TEMPERATURE

INPUT POWER = -20dBm, CURRENT = 65mA

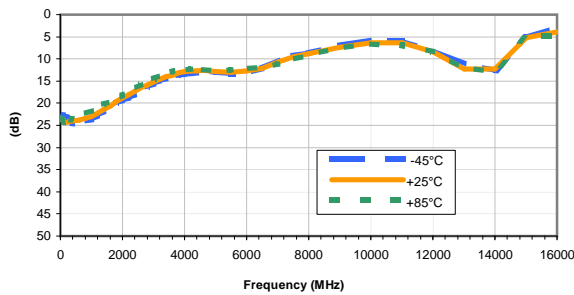

INPUT RETURN LOSS vs. CURRENT

INPUT POWER = -20dBm, Temperature = +25°C

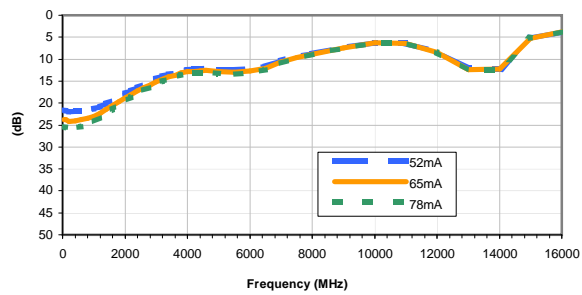

OUTPUT RETURN LOSS vs. TEMPERATURE

INPUT POWER = -20dBm, CURRENT = 65mA

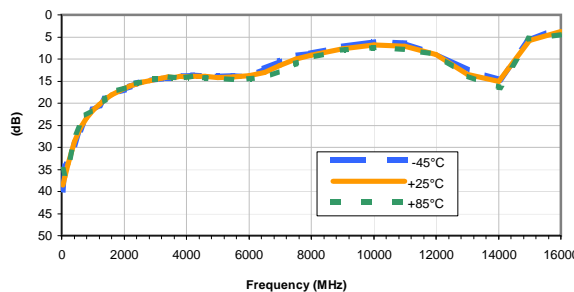

OUTPUT RETURN LOSS vs. CURRENT

INPUT POWER = -20dBm, Temperature = +25°C

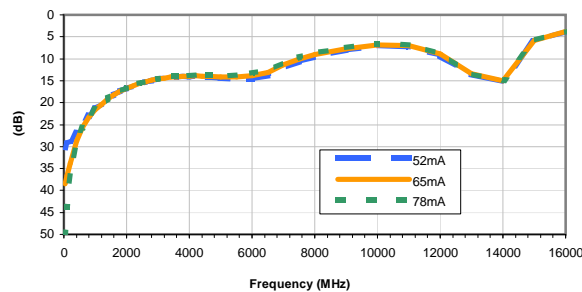

IF/RF MICROWAVE COMPONENTS • ISO 9001 ISO 14001 AS 9100 CERTIFIED • RoHS compliant
P.O. Box 350166, Brooklyn, New York 11235-0003 (718) 934-4500 Fax (718) 332-4661



The Design Engineers Search Engine finds the model you need, Instantly • For detailed performance specs & shopping online see



Typical Performance Curves

OUTPUT IP3 vs. TEMPERATURE

INPUT POWER = -20dBm, CURRENT = 65mA

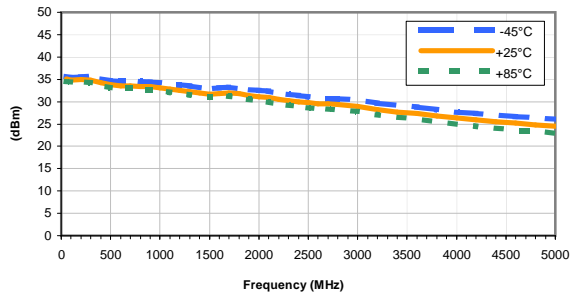

OUTPUT IP3 vs. CURRENT

INPUT POWER = -20dBm, Temperature = +25°C

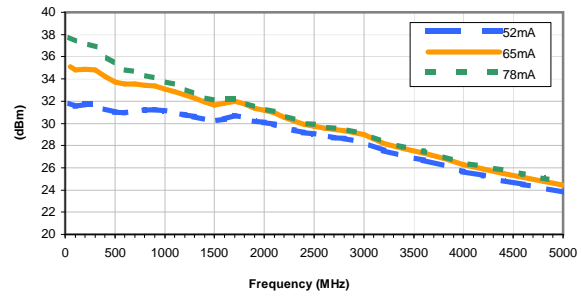

OUTPUT POWER at 1dB Compression vs. TEMPERATURE

CURRENT = 65mA

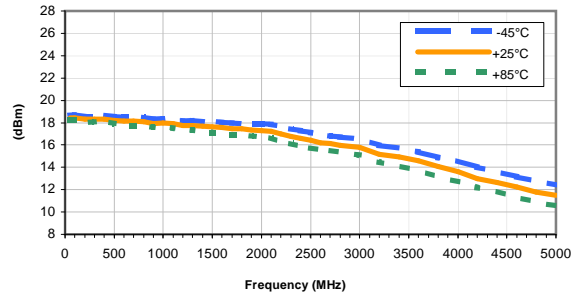

OUTPUT POWER at 1dB Compression vs. CURRENT

Temperature = +25°C

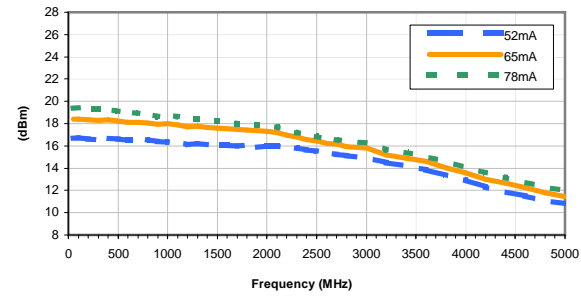

Noise Figure vs. TEMPERATURE

CURRENT = 65mA

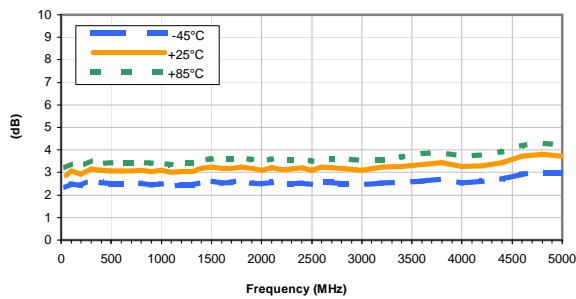

Noise Figure vs. CURRENT

Temperature = +25°C

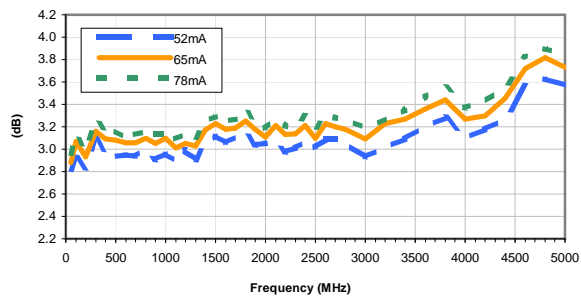

Outline Dimensions

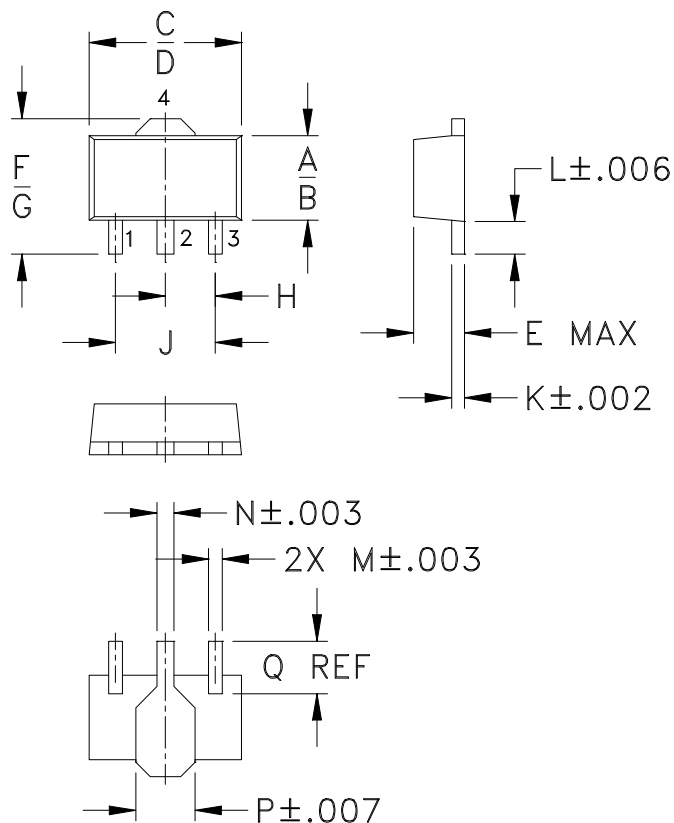

PCB Land Pattern

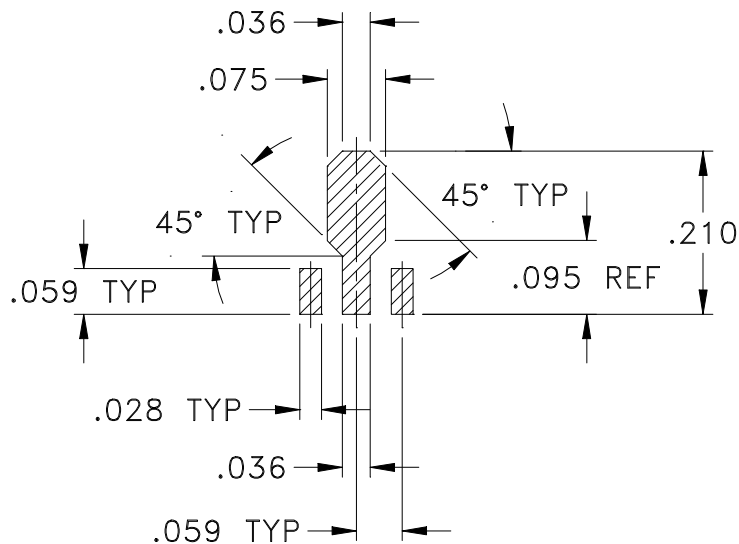

Suggested Layout,
Tolerance to be within $\pm .002$

CASE #	A	B	C	D	E	F	G	H	J	K	L	M
DF782	.102 (2.59)	.090 (2.29)	.181 (4.60)	.173 (4.39)	.063 (1.60)	.167 (4.24)	.155 (3.94)	.059 (1.50)	.118 (3.00)	.015 (0.38)	.041 (1.04)	.016 (0.41)

CASE #	N	P	Q	WT. GRAM
DF782	.019 (0.48)	.065 (1.65)	.062 (1.57)	.2

Dimensions are in inches (mm). Tolerances: 2 Pl. $\pm .01$; 3Pl. $\pm .005$

Notes:

- Case material: Plastic.
- Termination finish:
 For RoHS Case Styles: Tin-Silver alloy plate over Nickel barrier or Matte-Tin.
 All models, (+) suffix. See model Data sheet.
 For RoHS-5 Case Styles: Tin-Lead plate. All models, no (+) suffix.



INTERNET <http://www.minicircuits.com>

P.O. Box 350166, Brooklyn, New York 11235-0003 (718) 934-4500 Fax (718) 332-4661

Distribution Centers NORTH AMERICA 800-654-7949 • 417-335-5935 • Fax 417-335-5945 • EUROPE 44-1252-832600 • Fax 44-1252-837010

Mini-Circuits ISO 9001 & ISO 14001 Certified

Tape & Reel Packaging TR-F55

DEVICE ORIENTATION IN T&R

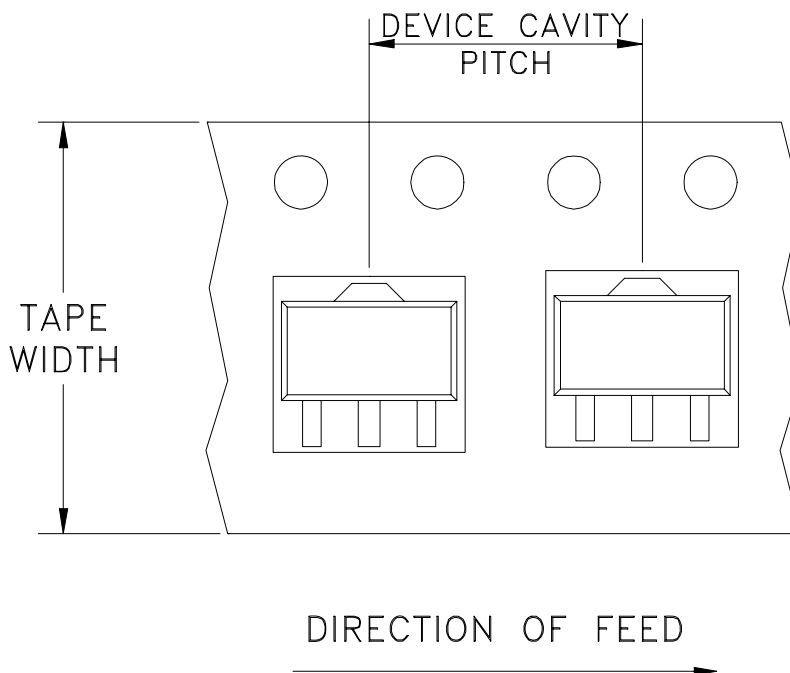

Tape Width, mm	Device Cavity Pitch, mm	Reel Size, inches	Devices per Reel	
12	8	7	Small quantity standard (see note)	20
				50
				100
				200
				500
			Standard	1000

Note: Please consult individual model data sheet to determine device per reel availability.

Mini-Circuits carrier tape materials provide protection from ESD (Electro-Static Discharge) during handling and transportation. Tapes are static dissipative and comply with industry standards EIA-481/EIA-541.

Go to: www.minicircuits.com/pages/pdfs/tape.pdf



INTERNET <http://www.minicircuits.com>

P.O. Box 350166, Brooklyn, New York 11235-0003 (718) 934-4500 Fax (718) 332-4661

Distribution Centers NORTH AMERICA 800-654-7949 • 417-335-5935 • Fax 417-335-5945 • EUROPE 44-1252-832600 • Fax 44-1252-837010

Mini-Circuits ISO 9001 & ISO 14001 Certified

THIRD ANGLE PROJECTION

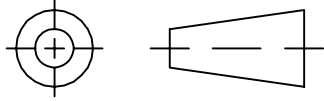

REVISIONS

REV	ECN No.	DESCRIPTION	DATE	DR	AUTH
A	M76190	CHANGED DISCRIPTION	04/01	GF	CT
B	M82575	UPDATED DRAWING	08/05/02	AV	LC
C	M102713	ADDED NOTE 2 & "...WITH SMOBC"	01/17/06	MMG	IL
D	M108434	UPDATED DRAWING PER TB-409+	11/14/06	PW	IG

SUGGESTED MOUNTING CONFIGURATION
FOR DF782 CASE STYLE, "mz" PIN CONNECTION

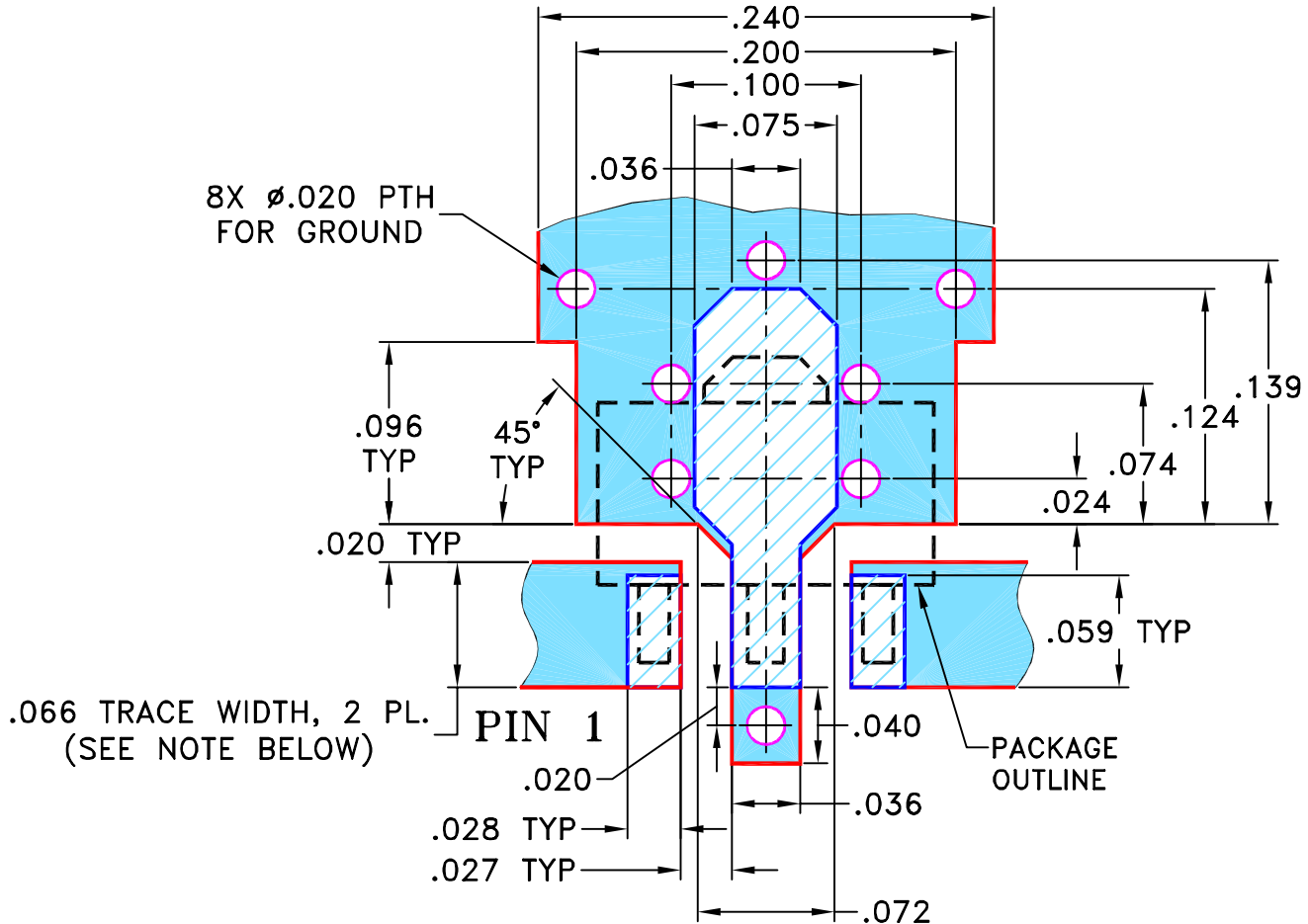

- NOTES:** 1. TRACE WIDTH IS SHOWN FOR ROGERS R04350B WITH DIELECTRIC THICKNESS .030" ± .002"; COPPER: 1/2 OZ. EACH SIDE. FOR OTHER MATERIALS TRACE WIDTH MAY NEED TO BE MODIFIED.
2. BOTTOM SIDE OF THE PCB IS CONTINUOUS GROUND PLANE.



DENOTES PCB COPPER LAYOUT WITH SMOBC (SOLDER MASK OVER BARE COPPER)



DENOTES COPPER LAND PATTERN FREE OF SOLDER MASK

UNLESS OTHERWISE SPECIFIED	INITIALS	DATE
DRAWN	AV	01/15/01
CHECKED	YB	01/23/01
APPROVED	DB	01/23/01

Mini-Circuits®
THIS DOCUMENT AND ITS CONTENTS ARE THE PROPERTY OF MINI-CIRCUITS. EXCEPT FOR USE EXPRESSLY GRANTED, IN WRITING, TO ITS VENDORS, VENDEE AND THE UNITED STATES GOVERNMENT, MINI-CIRCUITS RESERVES ALL PROPRIETARY DESIGN, USE, MANUFACTURING AND REPRODUCTION RIGHTS THERETO. THESE CONTENTS SHALL NOT BE USED, DUPLICATED OR DISCLOSED TO ANY OUTSIDE PARTY, IN WHOLE OR IN PART, WITHOUT WRITTEN PERMISSION OF MINI-CIRCUITS.

ASHEETA1.DWG REV:A DATE:01/12/95

Mini-Circuits® 13 Neptune Avenue
Brooklyn NY 11235

PL, mz, DF782, GALI, TB-409-XXX+

SIZE	CODE IDENT	DRAWING NO:	REV:
A	15542	98-PL-019	D
FILE:	98PL019	SCALE:	10:1
		SHEET:	1 OF 1

Evaluation Board and Circuit

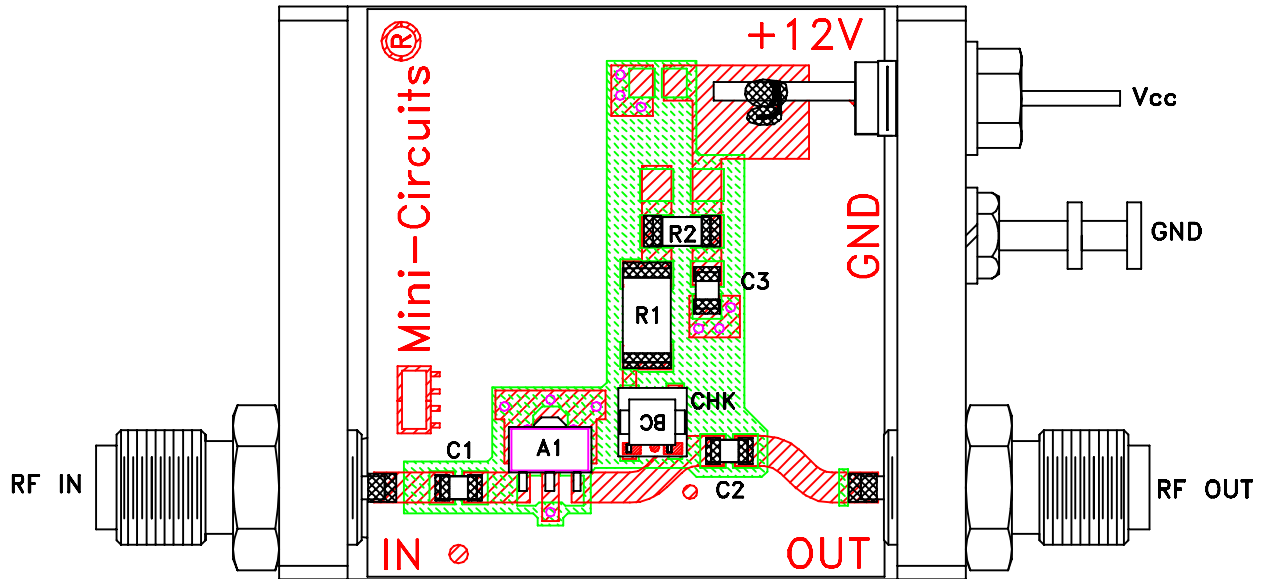

TB-409-59+

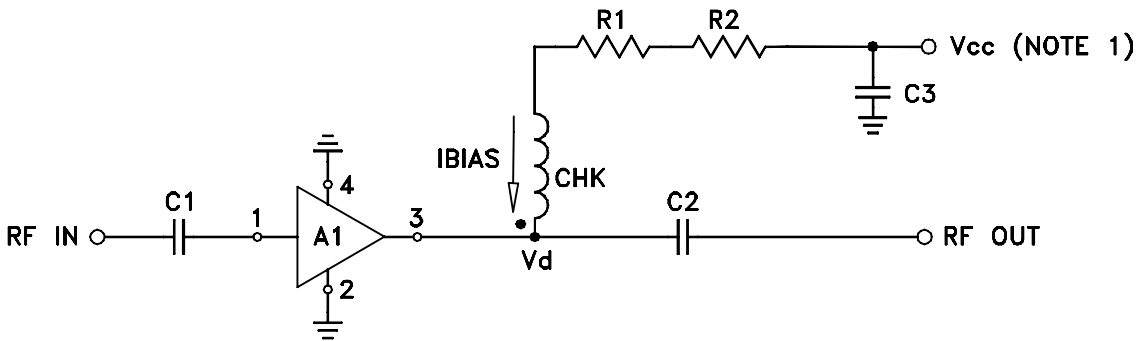

COMPONENT	VALUE
A1	Gali-59(+)
C1 (NOTE 4)	2400 pF
C2 (NOTE 4)	2400 pF
C3 (bypass)	0.1 uF
R1	110 Ohms, 0.75W
R2	0 Ohm, 0.25W
CHK	Mini-Circuits TCCH-80+

Schematic Diagram

NOTE:

1. Vcc voltage: $+12 \pm 0.2V$.
2. SMA Female connectors.
3. PCB material: Rogers R04350 or equivalent, dielectric constant=3.5, dielectric thickness=.030 inch.
4. Capacitors, C1 & C2 should be free of resonance up to the highest frequency specified.

 Mini-Circuits®

All Mini-Circuits products are manufactured under exacting quality assurance and control standards, and are capable of meeting published specifications after being subjected to any or all of the following physical and environmental test.

Specification	Test/Inspection Condition	Reference/Spec
Operating Temperature	-45° to 85°C or -40° to 85°C Ambient Environment	Individual Model Data Sheet
Storage Temperature	-65° to 150° C Ambient Environment	Individual Model Data Sheet
Thermal Shock	-55° to 100°C, 100 cycles	MIL-STD-202, Method 107, Condition A-3, except +100°C
Mechanical Shock	1.5Kg, 0.5 ms, 5 shock pulses, Y1 direction only	MIL-STD-883, Method 2002, Condition B, except Y1 direction only
Vibration (Variable Frequency)	50g peak	MIL-STD-883, Method 2007, Condition B
Autoclave	15 psig, 100% RH, 121°C, 96 hours	JESD22-A102, Condition C
HAST	130°C, 85% RH, 96 hours	JESD22-A110
Solderability	10X Magnification	J-STD-002, Para 4.2.5, Test S, 95% Coverage
Solder Reflow Heat	Sn-Pb Eutetic Process: 240°C peak Pb-Free Process: 260°C peak	J-STD-020, Table 4-1, 4-2 and 5-2; Figure 5-1
Moisture Sensitivity: Level 1	Bake at 125°C for 24 hours Soak at 85°C/85% RH for 168 hours, Reflow 3 cycles at 260°C peak	J-STD-020
Marking Resistance to Solvents	Isopropyl alcohol + mineral spirits at 25°C; terpene defluxer at 25°C; distilled water + proylene glycol monomethyl ether +	MIL-STD-202, Method 215



All Mini-Circuits products are manufactured under exacting quality assurance and control standards, and are capable of meeting published specifications after being subjected to any or all of the following physical and environmental test.

Specification	Test/Inspection Condition	Reference/Spec
	monoethanolamine at 63°C to 70°C	