

Ceramic High Pass Filter

HFCG-1100+

50Ω 1400 to 3900 MHz

The Big Deal

- Small size 2.0 mm x 1.25 mm
- High Power handling
- High rejection
- Ceramic construction



Generic photo used for illustration purposes only
CASE STYLE: GE0805C-2

Product Overview

The HFCG-1100+ LTCC High Pass Filter is constructed with 11 layers in order to achieve a miniature size and high repeatability of performance. Wrap-around terminations minimize variations in performance due to parasitics. Covering 1400-3900 MHz, these units offer low insertion loss and good rejection.

Key Features

Feature	Advantages
Small Size (2.0 mm x 1.25 mm)	Allows for high layout density of circuit boards, while minimizing effects of parasitic.
Wrap around termination	Provides excellent solderability and easy visual inspection capability.
LTCC construction	Provides a rugged package that is well suited for tough environments including high humidity and high temperature extremes.

Notes

- A. Performance and quality attributes and conditions not expressly stated in this specification document are intended to be excluded and do not form a part of this specification document.
B. Electrical specifications and performance data contained in this specification document are based on Mini-Circuit's applicable established test performance criteria and measurement instructions.
C. The parts covered by this specification document are subject to Mini-Circuits standard limited warranty and terms and conditions (collectively, "Standard Terms"); Purchasers of this part are entitled to the rights and benefits contained therein. For a full statement of the Standard Terms and the exclusive rights and remedies thereunder, please visit Mini-Circuits' website at www.minicircuits.com/MCLStore/terms.jsp



Ceramic High Pass Filter

HFCG-1100+

50Ω 1400 to 3900 MHz



Features

- Small size
- 7 sections
- Temperature stable
- Excellent power handling, 4W

Generic photo used for illustration purposes only
CASE STYLE: GE0805C-2

+RoHS Compliant
The +Suffix identifies RoHS Compliance. See our web site for RoHS Compliance methodologies and qualifications

Applications

- Transmitters / Receivers
- Global positioning system(GPS)
- Satellite broadcast applications

Electrical Specifications^{1,2} at 25°C

Parameter	F#	Frequency (MHz)	Min.	Typ.	Max.	Unit	
Stop Band	Rejection Loss	DC-F1	DC-530	40	53	-	dB
		DC-F2	DC-700	20	30	-	dB
	Freq. Cut-Off	F3 *	1050	-	3.0	-	dB
Pass Band	Insertion Loss	F4-F7	1400-3900	-	1.6	2.5	dB
		F5-F6	1500-3200	-	1.2	2	dB
	Return Loss	F4-F6	1400-3200	-	13	-	dB

¹ This component is not intended to act as a DC block. Please consult with Mini-Circuits for further details

² Measured on Mini-Circuits Characterization Test Board TB-1090+

* Typically, a ±5% frequency deviation from the stated value may occur on a unit-to-unit basis.

Functional Schematic

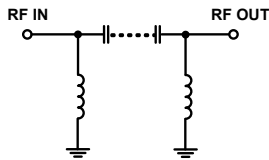

Maximum Ratings

Operating Temperature	-55°C to 125°C
Storage Temperature	-55°C to 125°C
RF Power Input*	4W at 25°C

*Passband rating, derate linearly to 0.8W at 125°C ambient

Permanent damage may occur if any of these limits are exceeded.

Typical Performance Data at 25°C

Frequency (MHz)	Insertion Loss (dB)	Return Loss (dB)
10	81.85	0.21
100	67.38	0.24
250	58.76	0.31
530	53.61	0.45
700	31.04	0.61
710	30.07	0.63
750	26.27	0.69
810	20.86	0.84
900	13.06	1.42
970	7.44	2.91
1040	3.33	7.51
1050	2.96	8.65
1100	1.78	17.21
1400	0.97	14.36
1500	0.78	18.13
2000	0.53	17.67
2500	0.44	18.98
3000	0.37	25.57
3200	0.42	18.07
3900	1.10	8.15

Typical Frequency Response

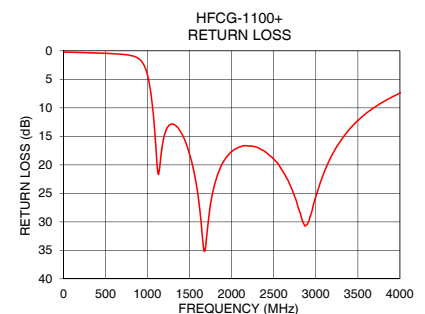
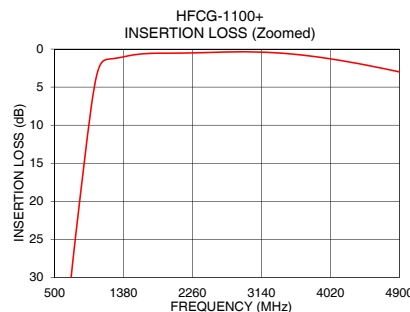
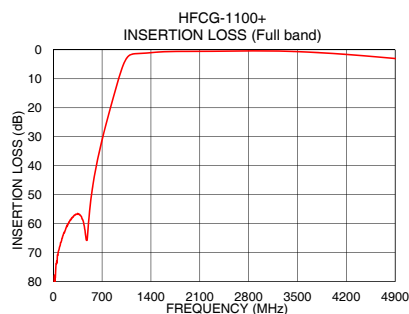
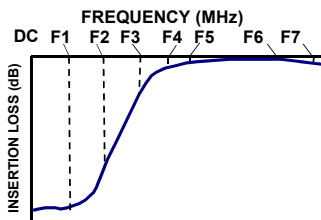

Notes

- A. Performance and quality attributes and conditions not expressly stated in this specification document are intended to be excluded and do not form a part of this specification document.
 B. Electrical specifications and performance data contained in this specification document are based on Mini-Circuit's applicable established test performance criteria and measurement instructions.
 C. The parts covered by this specification document are subject to Mini-Circuits standard limited warranty and terms and conditions (collectively, "Standard Terms"); Purchasers of this part are entitled to the rights and benefits contained therein. For a full statement of the Standard Terms and the exclusive rights and remedies thereunder, please visit Mini-Circuits' website at www.minicircuits.com/MCLStore/terms.jsp



www.minicircuits.com P.O. Box 350166, Brooklyn, NY 11235-0003 (718) 934-4500 sales@minicircuits.com

REV. A
ECO-012606
HFCG-1100+
EDU3266
URJ
220331
Page 2 of 3

Pad Connections

INPUT	8
OUTPUT	4
GROUND	1,2,3,5,6,7

Product Marking: LB

Demo Board MCL P/N: TB-1090+
Suggested PCB Layout (PL-615)

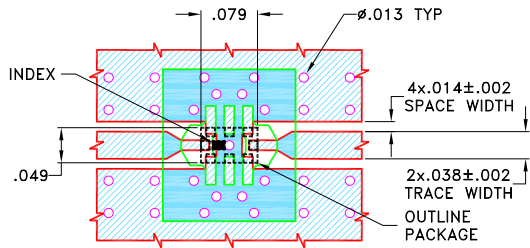

NOTES:

- TRACE WIDTH IS SHOWN FOR ROGERS (R04350B) WITH DIELECTRIC THICKNESS $.020 \pm .0015$ ". COPPER: 1/2 Oz. EACH SIDE. FOR OTHER MATERIALS TRACE WIDTH MAY NEED TO BE MODIFIED.
- BOTTOM SIDE OF THE PCB IS CONTINUOUS GROUND PLANE.

- DENOTES PCB COPPER LAYOUT WITH SMOBC (SOLDER MASK OVER BARE COPPER)
- DENOTES COPPER LAND PATTERN FREE OF SOLDERMASK

Outline Drawing

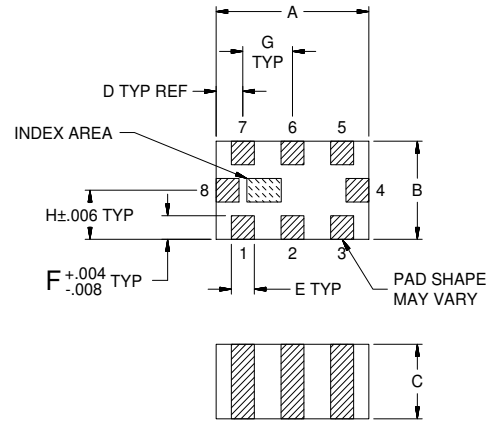

Outline Dimensions (inch / mm)

A	B	C	D	E	F	G	H	Wt.
.079	.049	.037	.014	.012	.012	.026	.025	grams
2.00	1.25	0.95	0.35	0.30	0.30	0.65	0.63	.008

Note: Please refer to case style drawing for details

Notes

- A. Performance and quality attributes and conditions not expressly stated in this specification document are intended to be excluded and do not form a part of this specification document.
 B. Electrical specifications and performance data contained in this specification document are based on Mini-Circuit's applicable established test performance criteria and measurement instructions.
 C. The parts covered by this specification document are subject to Mini-Circuits standard limited warranty and terms and conditions (collectively, "Standard Terms"); Purchasers of this part are entitled to the rights and benefits contained therein. For a full statement of the Standard Terms and the exclusive rights and remedies thereunder, please visit Mini-Circuits' website at www.minicircuits.com/MCLStore/terms.jsp

Typical Performance Data

FREQ. (MHz)	INSERTION LOSS			INPUT RETURN LOSS			OUTPUT RETURN LOSS		
	(dB)			(dB)			(dB)		
	@-40°C	@+25°C	@+85°C	@-40°C	@+25°C	@+85°C	@-40°C	@+25°C	@+85°C
10	85.48	81.85	84.09	0.17	0.21	0.24	0.16	0.20	0.23
50	73.14	72.82	72.05	0.18	0.22	0.25	0.17	0.21	0.24
100	67.17	67.38	67.21	0.20	0.24	0.27	0.19	0.24	0.27
150	63.36	63.39	63.31	0.22	0.26	0.30	0.22	0.26	0.30
200	60.62	60.46	60.76	0.24	0.29	0.32	0.25	0.29	0.32
250	58.52	58.76	58.72	0.26	0.31	0.34	0.26	0.31	0.35
300	57.11	57.13	57.17	0.28	0.34	0.37	0.28	0.34	0.38
350	56.68	56.49	56.74	0.30	0.36	0.40	0.29	0.36	0.41
400	57.46	57.49	57.70	0.31	0.38	0.43	0.31	0.39	0.44
450	61.17	61.78	61.80	0.33	0.41	0.46	0.34	0.41	0.47
500	63.44	61.36	59.87	0.36	0.44	0.49	0.36	0.44	0.50
530	54.61	53.61	52.78	0.37	0.45	0.51	0.37	0.46	0.52
600	42.76	42.15	41.69	0.41	0.51	0.57	0.41	0.51	0.58
650	36.72	36.23	35.80	0.45	0.55	0.62	0.45	0.56	0.63
700	31.51	31.04	30.63	0.50	0.61	0.69	0.50	0.62	0.71
750	26.72	26.27	25.87	0.56	0.69	0.78	0.57	0.71	0.81
800	22.18	21.75	21.34	0.66	0.81	0.92	0.68	0.83	0.95
850	17.78	17.36	16.95	0.84	1.02	1.16	0.86	1.05	1.21
900	13.47	13.06	12.67	1.18	1.42	1.63	1.21	1.48	1.69
950	9.35	8.96	8.63	1.92	2.30	2.63	1.98	2.38	2.74
1000	5.68	5.41	5.20	3.62	4.30	4.87	3.73	4.47	5.08
1050	3.03	2.96	2.93	7.43	8.65	9.60	7.70	9.07	10.12
1100	1.68	1.78	1.86	15.26	17.21	18.46	16.49	19.33	21.28
1150	1.25	1.41	1.52	20.89	19.57	18.96	23.06	20.72	19.75
1200	1.15	1.31	1.41	15.15	14.79	14.80	15.20	14.76	14.72
1250	1.12	1.25	1.34	13.06	13.14	13.40	12.91	12.94	13.16
1300	1.06	1.17	1.25	12.51	12.85	13.24	12.34	12.62	12.98
1350	0.97	1.08	1.14	12.76	13.33	13.82	12.52	13.02	13.47
1400	0.88	0.97	1.03	13.58	14.36	14.94	13.31	14.01	14.52
1450	0.78	0.87	0.94	14.98	15.94	16.62	14.62	15.47	16.06
1500	0.68	0.78	0.85	16.99	18.13	18.93	16.45	17.43	18.08
1550	0.61	0.71	0.78	19.68	21.11	22.09	18.87	19.98	20.70
1600	0.55	0.65	0.72	23.24	25.34	26.66	21.80	23.15	23.90
1650	0.50	0.61	0.68	28.59	32.32	34.00	25.21	26.55	27.04
1700	0.47	0.58	0.65	34.85	32.93	31.88	27.65	27.46	27.32
1750	0.45	0.56	0.63	29.62	26.73	26.21	26.55	25.20	24.99
1800	0.44	0.55	0.61	24.96	23.29	23.08	23.83	22.70	22.62
1850	0.43	0.54	0.61	22.03	21.07	20.99	21.49	20.77	20.80
1900	0.43	0.54	0.61	20.04	19.48	19.51	19.80	19.38	19.49
1950	0.43	0.54	0.60	18.75	18.43	18.51	18.63	18.40	18.56
2000	0.43	0.53	0.60	17.89	17.67	17.79	17.82	17.69	17.88
2100	0.43	0.53	0.59	16.90	16.85	17.01	16.85	16.89	17.12
2200	0.41	0.51	0.57	16.57	16.71	16.88	16.51	16.74	17.00
2300	0.39	0.49	0.55	16.56	16.92	17.10	16.58	17.05	17.32
2400	0.37	0.47	0.52	17.13	17.71	17.90	17.18	17.88	18.16
2500	0.34	0.44	0.50	18.12	18.98	19.19	18.19	19.20	19.55
2600	0.31	0.41	0.47	19.71	20.95	21.18	19.72	21.21	21.64
2700	0.28	0.39	0.45	22.32	23.77	24.02	22.39	24.35	24.97
2800	0.26	0.37	0.44	26.55	27.88	27.87	27.54	30.50	31.84
2900	0.25	0.37	0.43	30.99	30.39	29.21	40.57	47.08	40.18
3000	0.25	0.37	0.44	27.14	25.57	24.67	29.72	27.57	26.51
3100	0.26	0.38	0.46	21.96	21.23	20.65	22.59	21.86	21.28
3200	0.30	0.42	0.50	18.48	18.07	17.65	18.77	18.36	17.94
3300	0.35	0.48	0.56	16.06	15.69	15.36	16.16	15.82	15.51
3400	0.41	0.55	0.63	14.06	13.76	13.49	14.16	13.90	13.64
3500	0.49	0.63	0.72	12.46	12.22	12.01	12.52	12.32	12.12
3700	0.69	0.84	0.93	10.04	9.89	9.74	10.05	9.92	9.78
3800	0.82	0.96	1.06	9.02	8.95	8.83	9.02	8.99	8.89
3850	0.89	1.03	1.13	8.57	8.55	8.44	8.58	8.59	8.49
3900	0.96	1.10	1.20	8.14	8.15	8.06	8.15	8.19	8.10

Typical Performance Data

FREQ. (MHz)	GROUP DELAY		
	(nsec)		
	@-40°C	@+25°C	@+85°C
1000	1.36	1.39	1.40
1050	1.52	1.49	1.46
1100	1.38	1.32	1.27
1150	1.10	1.05	1.01
1200	0.86	0.82	0.80
1250	0.74	0.71	0.69
1300	0.64	0.61	0.60
1350	0.57	0.55	0.54
1400	0.52	0.50	0.49
1450	0.48	0.47	0.46
1500	0.45	0.43	0.43
1550	0.42	0.41	0.40
1600	0.40	0.38	0.37
1650	0.37	0.36	0.35
1700	0.35	0.34	0.33
1750	0.33	0.31	0.31
1800	0.31	0.29	0.29
1850	0.29	0.28	0.27
1900	0.28	0.26	0.26
2000	0.25	0.24	0.23
2100	0.23	0.22	0.21
2200	0.21	0.20	0.19
2300	0.20	0.19	0.18
2400	0.19	0.17	0.17
2500	0.18	0.17	0.16
2600	0.17	0.16	0.16
2700	0.17	0.16	0.15
2800	0.16	0.15	0.14
2900	0.16	0.15	0.14
3000	0.15	0.14	0.14
3100	0.15	0.14	0.14
3200	0.15	0.14	0.13
3300	0.14	0.13	0.13
3400	0.14	0.13	0.12
3500	0.14	0.12	0.12
3600	0.13	0.12	0.12
3700	0.13	0.12	0.11
3800	0.13	0.11	0.11
3900	0.12	0.11	0.10
3950	0.12	0.11	0.10
4000	0.12	0.11	0.10

Typical Performance Curves

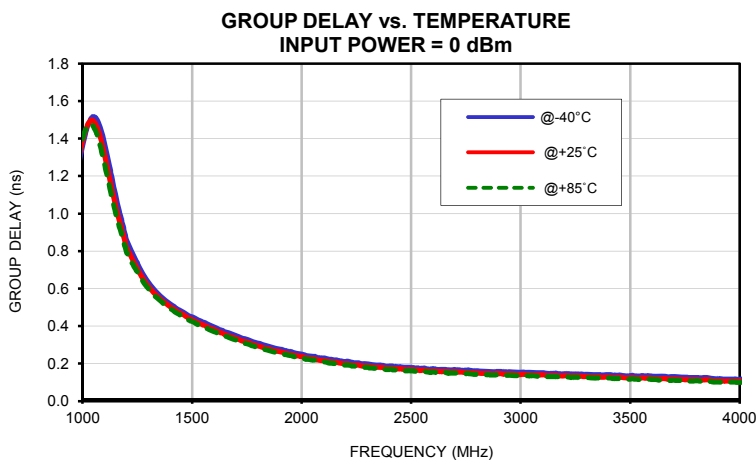
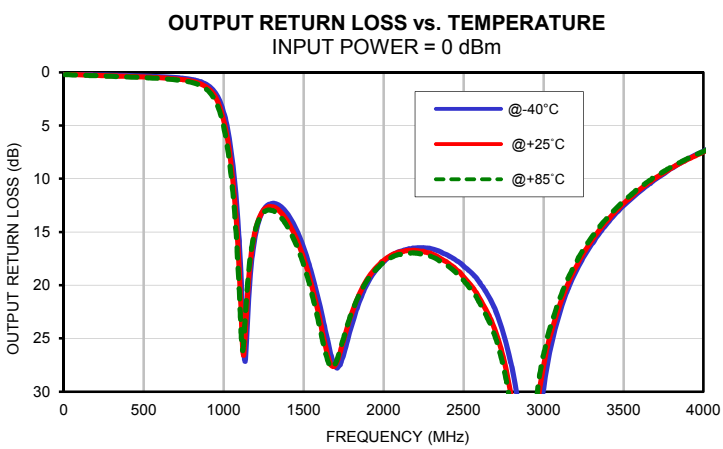
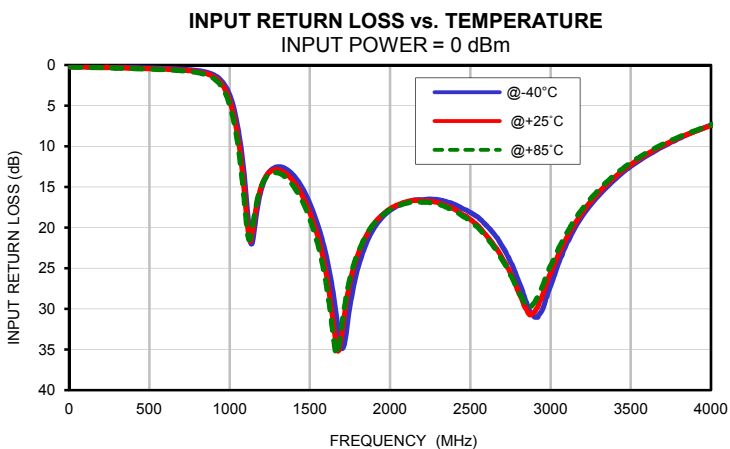
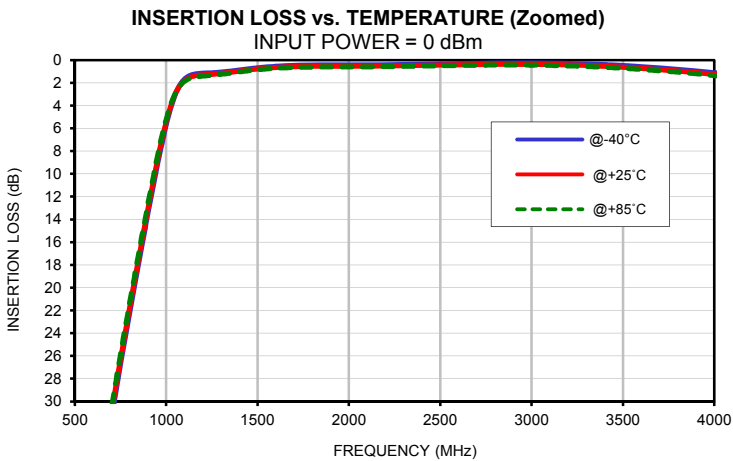
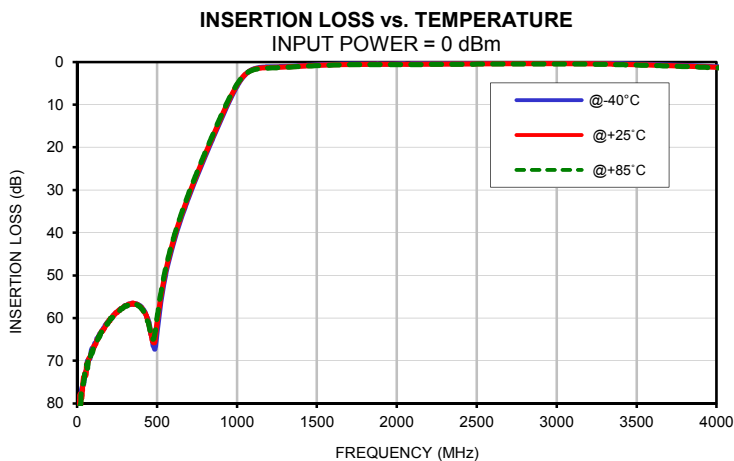

Outline Dimensions

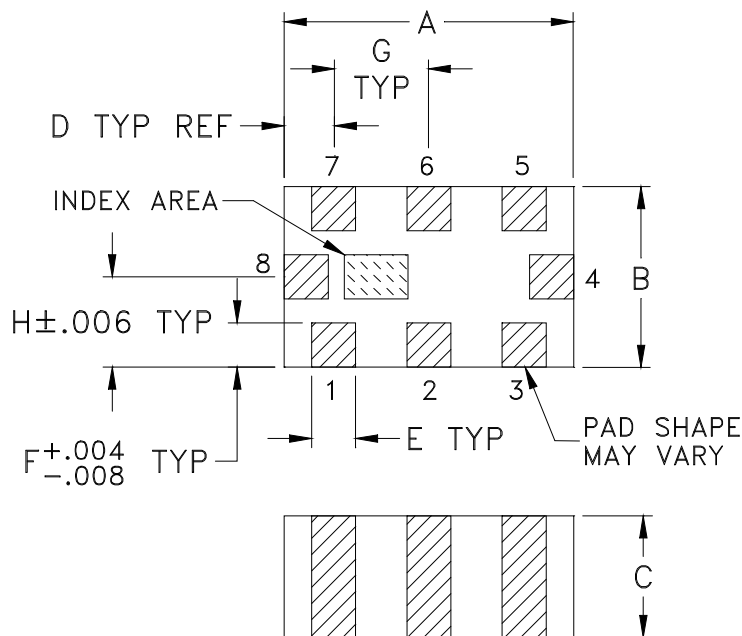

PCB Land Pattern

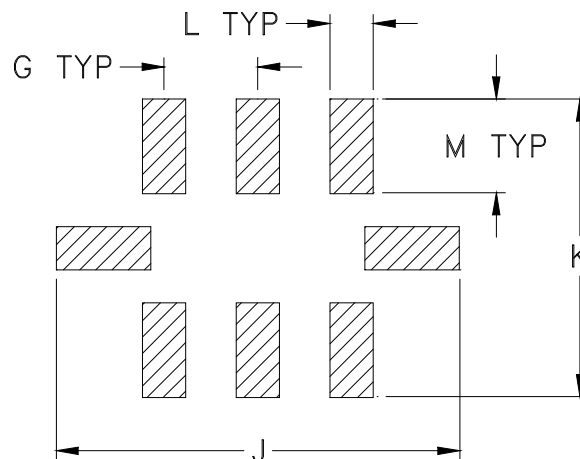

Suggested Layout,
Tolerance to be within $\pm .002$

CASE #	A	B	C	D	E	F	G	H	J	K	L
GE0805C-2	.079 (2.00)	.049 (1.25)	.037 (0.95)	.014 (0.35)	.012 (0.30)	.012 (0.30)	.026 (0.65)	.025 (0.63)	.134 (3.40)	.110 (2.80)	.014 (0.35)

CASE #	M	WT. GRAM
GE0805C-2	.039 (1.00)	.008

Dimensions are in inches (mm). Tolerances: 2Pl. $\pm .01$; 3 Pl. $\pm .005$

Notes:

- Open style, ceramic base.
- Termination finish: For RoHS Case Styles: Tin plate over Nickel plate. All models, (+) suffix.
For RoHS-5 Case Styles: Tin-Lead plate over Nickel plate. All models, no (+) suffix.
- Pad tolerance to be non-cumulative. Minimum spacing between each pad is .004 (0.1).



P.O. Box 350166, Brooklyn, New York 11235-0003 (718) 934-4500 Fax (718) 332-4661 For detailed performance specs & shopping online see Mini-Circuits web site



The Design Engineers Search Engine Provides ACTUAL Data Instantly From MINI-CIRCUITS At: www.minicircuits.com

RF/IF MICROWAVE COMPONENTS

Tape & Reel Packaging TR-F114

DEVICE ORIENTATION IN T&R



ILLUSTRATION 1

Applicable Case Styles	
GE0805C	JC0603C
GE0805C-1	JC0603C-4
GE0805C-1AP	JC0603C-6
GE0805C-7	
GE0805C-9	
GE0805C-10	
GE0805C-11	
GE0805C-12	



ILLUSTRATION 2

Applicable Case Styles	
GE0805C-2	JC0603C-1
GE0805C-3	JC0603C-2
GE0805C-4	JC0603C-3
GE0805C-5	JC0603C-5
GE0805C-6	JC0603C-7
GE0805C-8	
GE0805C-15	

Tape Width, mm	Device Cavity Pitch, mm	Reel Size, inches	Devices per Reel	
8	4	7	Small quantity standards (see note)	20
				50
				100
				200
				500
				1000
			Standard	4000

Note: Please Consult individual model data sheet to determine device per reel availability.

Mini-Circuits carrier tape materials provide protection from ESD (Electro-Static Discharge) during handling and transportation. Tapes are static dissipative and comply with industry standards EIA-481/EIA-541.

Go to: www.minicircuits.com/pages/pdfs/tape.pdf



INTERNET <http://www.minicircuits.com>

P.O. Box 350166, Brooklyn, New York 11235-0003 (718) 934-4500 Fax (718) 332-4661

Distribution Centers NORTH AMERICA 800-654-7949 • 417-335-5935 • Fax 417-335-5945 • EUROPE 44-1252-832600 • Fax 44-1252-837010

Mini-Circuits ISO 9001 & ISO 14001 Certified

THIRD ANGLE PROJECTION

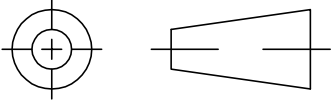

REVISIONS

REV	ECN No.	DESCRIPTION	DATE	DR	AUTH
OR	M171090	NEW RELEASE	MAR 19	DDR	VC

SUGGESTED MOUNTING CONFIGURATION FOR
GE0805C-2 CASE STYLE "08FL07" PIN CODE

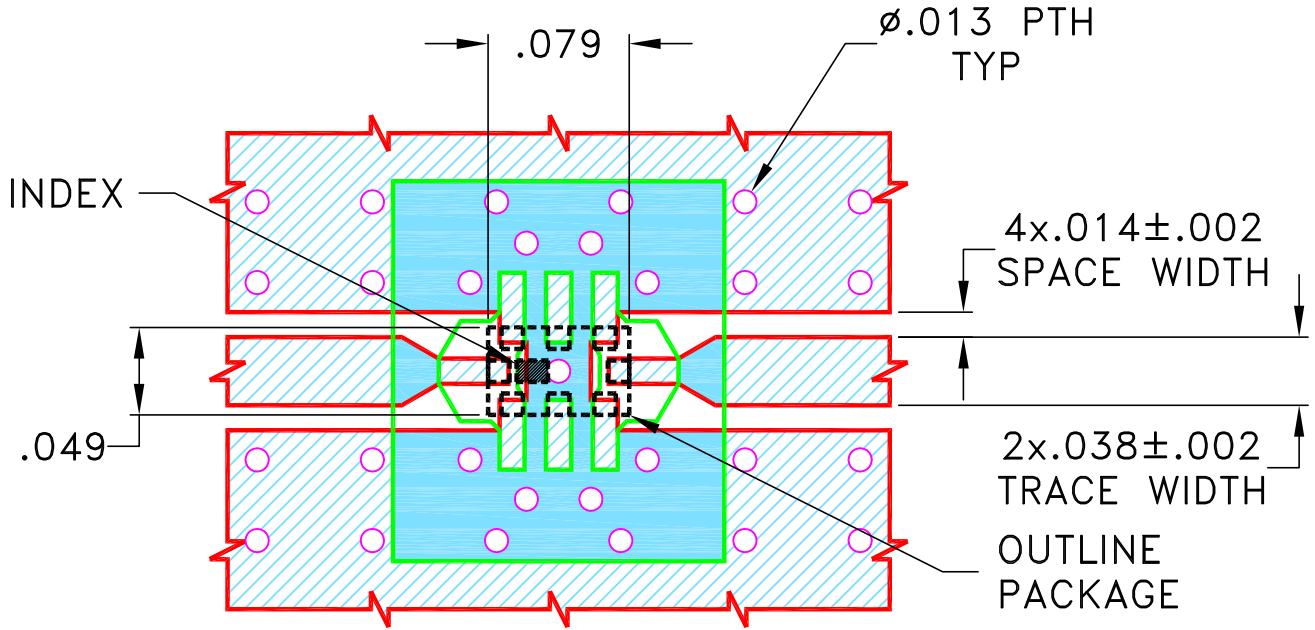

NOTES:

- TRACE WIDTH IS SHOWN FOR ROGERS (R04350B) WITH DIELECTRIC THICKNESS .020"±.0015". COPPER: 1/2 Oz. EACH SIDE.
FOR OTHER MATERIALS TRACE WIDTH MAY NEED TO BE MODIFIED.
- BOTTOM SIDE OF THE PCB IS CONTINUOUS GROUND PLANE.



DENOTES PCB COPPER LAYOUT WITH SMOBC
(SOLDER MASK OVER BARE COPPER)



DENOTES COPPER LAND PATTERN FREE OF SOLDERMASK

UNLESS OTHERWISE SPECIFIED	INITIALS	DATE
DIMENSIONS ARE IN INCHES	DRAWN DDR	01 MAR 19
TOLERANCES ON:	CHECKED RV	01 MAR 19
2 PL DECIMALS ±	APPROVED RKS	01 MAR 19
3 PL DECIMALS ± .005"		
ANGLES ±		
FRACTIONS ±		



Mini-Circuits® 13 Neptune Avenue
Brooklyn NY 11235

PL, 08FL07, GE0805C-2
TB-1090+, 50 OHM

SIZE A	CODE IDENT 15542	DRAWING NO: 98-PL-615	REV: OR
FILE:	98PL615	SCALE: 9:1	SHEET: 1 OF 1

Mini-Circuits®
THIS DOCUMENT AND ITS CONTENTS ARE THE PROPERTY OF MINI-CIRCUITS. EXCEPT FOR USE EXPRESSLY GRANTED, IN WRITING, TO ITS VENDORS, VENDEE AND THE UNITED STATES GOVERNMENT, MINI-CIRCUITS RESERVES ALL PROPRIETARY DESIGN, USE, MANUFACTURING AND REPRODUCTION RIGHTS THERETO. THESE CONTENTS SHALL NOT BE USED, DUPLICATED OR DISCLOSED TO ANY OUTSIDE PARTY, IN WHOLE OR IN PART, WITHOUT WRITTEN PERMISSION OF MINI-CIRCUITS.

Evaluation Board and Circuit

TB-1090+

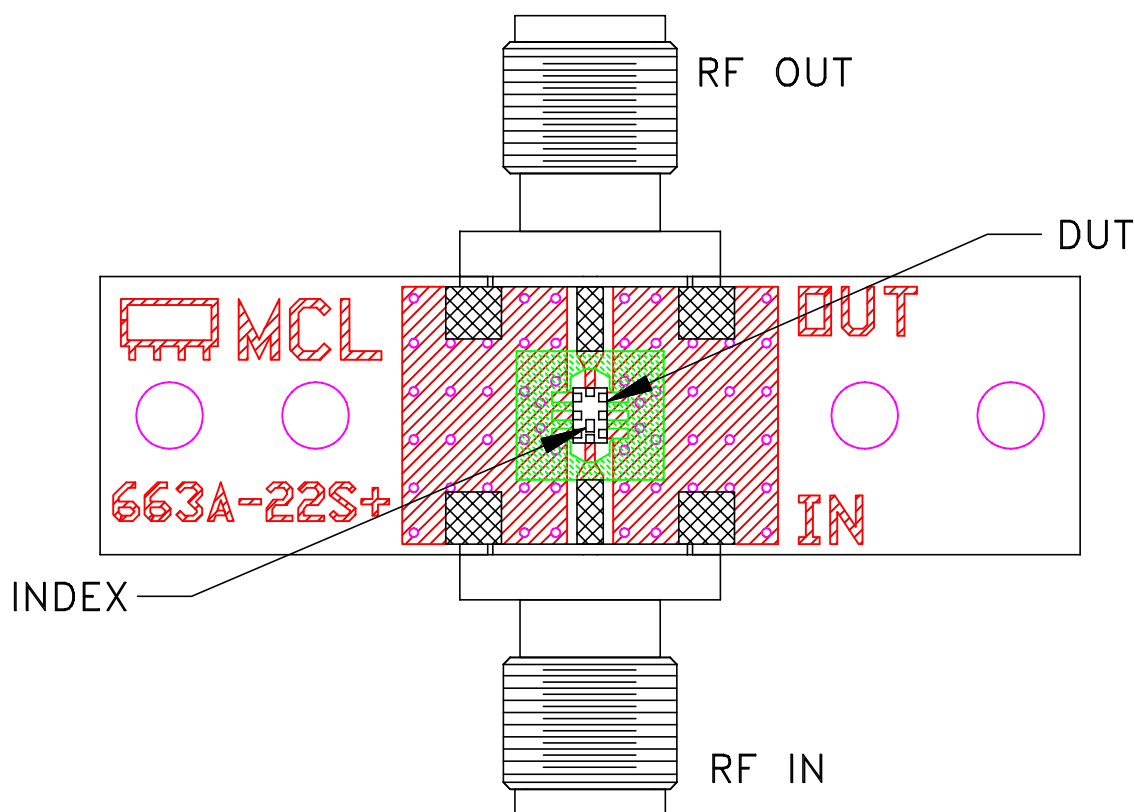

Schematic diagram

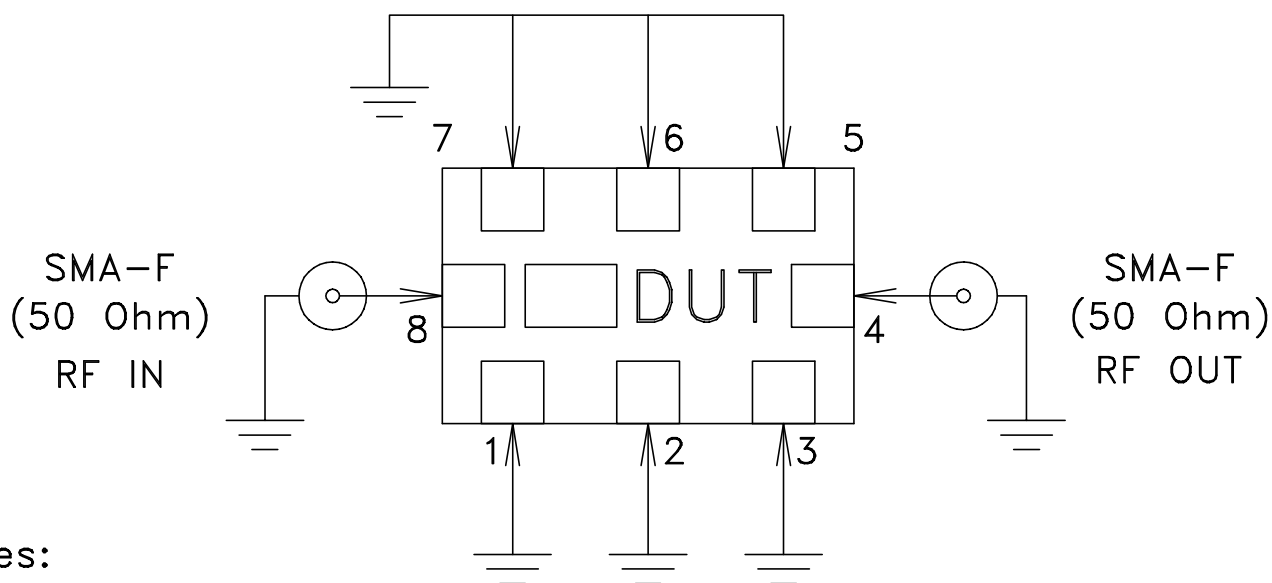

Notes:

1. 50 Ohm SMA Female connectors.
2. PCB Material: ROGERS (R04350B), OR Equivalent
Dielectric Constant=3.48, Thickness=.020inch.

 **Mini-Circuits®**



All Mini-Circuits products are manufactured under exacting quality assurance and control standards, and are capable of meeting published specifications after being subjected to any or all of the following physical and environmental test.

Specification	Test/Inspection Condition	Reference/Spec
Operating Temperature	-55° to 100°C Ambient Environment	Individual Model Data Sheet
Storage Temperature	-55° to 100° C Ambient Environment	Individual Model Data Sheet
Humidity	90 to 95% RH, 240 hours, 50°C	MIL-STD-202, Method 103, Condition A, Except 50°C and end-point electrical test done within 12 hours
Solder Reflow Heat	Sn-Pb Eutetic Process: 225°C peak Pb-Free Process 245° - 250°C peak	J-STD-020, Table 4-1, 4-2 and 5-2, Figure 5-1
Solderability	10X Magnification	J-STD-002, Para 4.2.5, Test S, 95% Coverage
Vibration (High Frequency)	20g peak, 10-2000 Hz, 12 times in each of three perpendicular directions (total 36)	MIL-STD-202, Method 204, Condition D
Mechanical Shock	50g, 11 ms, 1/2-sine, 18 shocks: 3 each direction, each of 3 axes	MIL-STD-202, Method 213, Condition A