



CERAMIC

High Pass Filter

HFCQ-2902+

Mini-Circuits

50Ω 29 to 39 GHz

THE BIG DEAL

- Standard small 1008 (2.5mm x 2.0mm) case style
- Low Insertion Loss – Passband 1.5 dB typical
- Shielded construction preventing filter from de-tuning
- Reduced footprint area by employing LGA (land grid array)
- Surface mountable pick and place standard case style
- Patent pending



Generic photo used for illustration purposes only

CASE STYLE: NL1008C-6

+RoHS Compliant

The +Suffix identifies RoHS Compliance. See our web site for RoHS Compliance methodologies and qualifications

APPLICATIONS

- Test and Measurement

PRODUCT OVERVIEW

The HFCQ-2902+ LTCC High Pass Filter achieves a miniature size and high repeatability of performance by utilizing a proprietary LTCC material system and distributed filter topology. The typical passband loss at 29.0 – 39.0 GHz is as low as 1.5 dB, with typical stopband rejections at 25 dB up to 21.9 GHz. This model handles up to 1W RF input power, and provides a wide operating temperature range from -55 to +125°C. Utilizing a proprietary LTCC material system and a distributed filter topology, this filter is able to achieve repeatable performance on a lot-to-lot basis.

KEY FEATURES

Feature	Advantages
Cost effective	LTCC is scalable technology that is cost effective due to ease of production in high quantities.
Small size (2.5mm x 2.0mm)	Allows for high layout density of circuit boards, while minimizing effects of parasitics.
Surface Mountable	Suitable for very high volume automated assembly process.

REV. OR
NPO-002619
HFCQ-2902+
CGD/CP/AM
032125





CERAMIC

High Pass Filter

HFCQ-2902+

ELECTRICAL SPECIFICATIONS¹ AT 25°C

Parameter	F#	Frequency (GHz)	Min.	Typ.	Max.	Units
Stop Band	DC-F1	0.1 - 15	30	40	—	dB
	F1-F2	15 - 21.9	18	25	—	dB
Pass Band	F3-F4	29 - 39	—	1.5	2.75	dB
	F3-F4	29 - 39	—	13	—	dB

1. Measured on Mini-Circuits Test Board TB-HFCQ-2902C+ with connectors and feedlines de-embedded.

MAXIMUM RATINGS

Parameter	Ratings
Operating temperature	-55°C to +125°C
Storage temperature	-55°C to +125°C
RF Power Input	1W

Permanent damage may occur if any of these limits are exceeded.

TYPICAL FREQUENCY RESPONSE

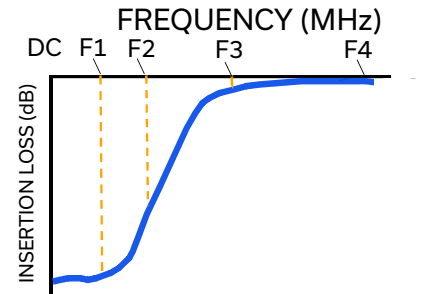

FUNCTIONAL SCHEMATIC

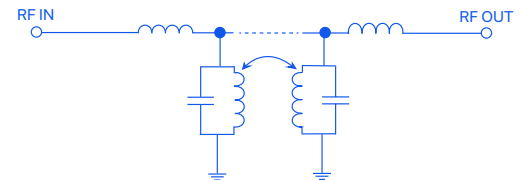



CERAMIC

High Pass Filter

HFCQ-2902+

PAD CONNECTIONS

INPUT	1
OUTPUT	2
GROUND	3

PRODUCT MARKING: UP

DEMO BOARD MCL P/N: TB-HFCQ-2902C+ SUGGESTED PCB LAYOUT (PL-707)

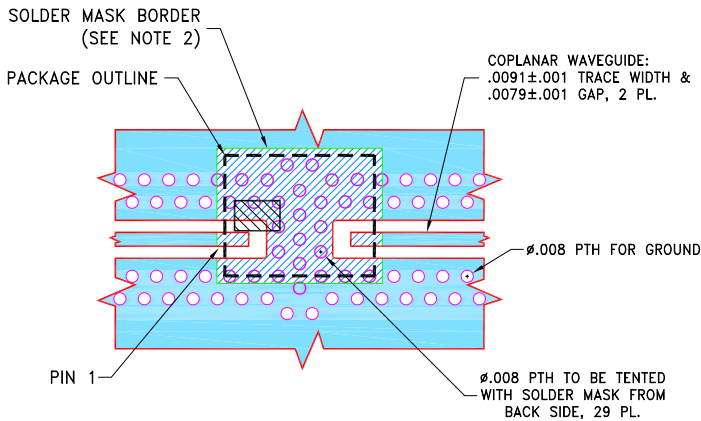

NOTES:

1. COPLANAR WAVEGUIDE PARAMETERS ARE SHOWN FOR MEGTRON-7 R5785(N); DIELECTRIC THICKNESS: .0049±.001; CLOTH STYLE: 2116; COPPER: HVLP/HVLP. FOR OTHER MATERIALS LINE WIDTH & GAP MAY NEED TO BE MODIFIED.
2. SOLDER MASK OPENING FOR COMPONENT SOLDERING HAS BEEN INCREASED AGAINST PCB LAND PATTERN RECOMMENDATIONS PER NL1008C-6 AND CAN BE DEVIATED FROM THIS DRAWING TO COMPLY WITH CUSTOMERS' DESIGN RULES.
3. BOTTOM SIDE OF THE PCB IS CONTINUOUS GROUND PLANE.

- DENOTES PCB COPPER LAYOUT WITH SMOBC (SOLDER MASK OVER BARE COPPER).
- DENOTES COPPER LAND PATTERN FREE OF SOLDER MASK.

OUTLINE DRAWING

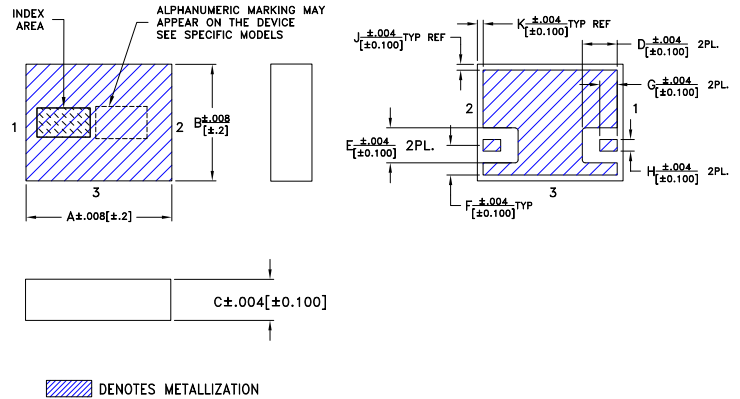

OUTLINE DIMENSIONS (Inches / mm)

A	B	C	D	E	F	G	H	J	K	wt
.098	.079	.028	.024	.024	.020	.012	.008	.004	.004	grams
2.49	2.01	0.71	0.6	0.6	0.51	0.3	0.2	0.1	0.1	.019



CERAMIC

High Pass Filter

HFCQ-2902+

TYPICAL PERFORMANCE DATA AT 25°C

Frequency (MHz)	Insertion Loss (dB)	Return Loss (dB)
100	91.15	0.07
1000	71.61	0.24
10000	50.57	0.15
15000	41.06	0.16
20000	30.17	0.25
21900	24.96	0.26
25000	13.82	0.47
29000	0.64	24.55
30000	0.68	17.25
36000	0.49	27.16
38000	0.85	27.93
39000	1.11	20.03

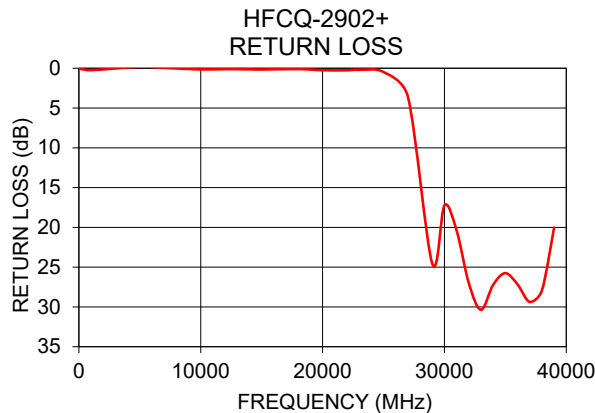
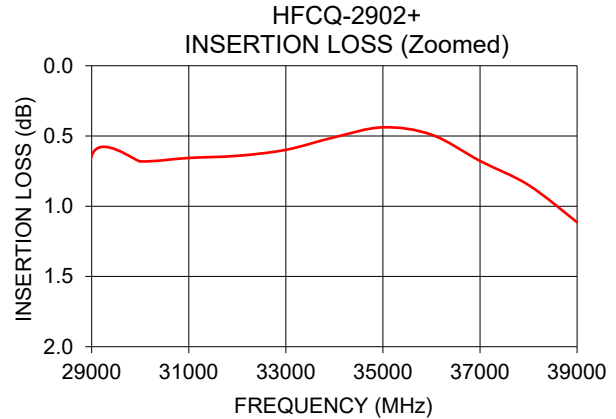
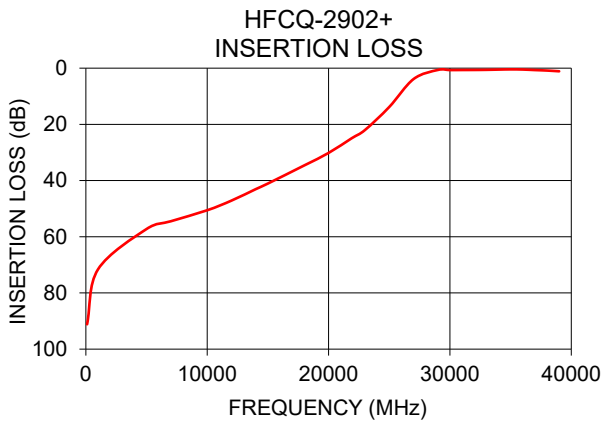

NOTES

- A. Performance and quality attributes and conditions not expressly stated in this specification document are intended to be excluded and do not form a part of this specification document.
- B. Electrical specifications and performance data contained in this specification document are based on Mini-Circuit's applicable established test performance criteria and measurement instructions.
- C. The parts covered by this specification document are subject to Mini-Circuits standard limited warranty and terms and conditions (collectively, "Standard Terms"); Purchasers of this part are entitled to the rights and benefits contained therein. For a full statement of the standard. Terms and the exclusive rights and remedies thereunder, please visit Mini-Circuits' website at www.minicircuits.com/terms/viewterm.html



Typical Performance Data

FREQUENCY (MHz)	INSERTION LOSS (dB)	RETURN LOSS (dB)
100	91.15	0.07
500	77.18	0.16
1000	71.61	0.24
2000	65.59	0.17
3000	61.75	0.04
4000	59.13	0.09
5000	57.25	0.18
6000	55.80	0.16
7000	54.49	0.05
8000	53.24	0.06
9000	51.96	0.13
10000	50.57	0.15
11000	48.97	0.13
12000	47.13	0.11
13000	45.12	0.11
14000	43.05	0.14
15000	41.06	0.16
16000	39.03	0.15
17000	36.85	0.10
18000	34.61	0.10
19000	32.46	0.19
20000	30.17	0.25
21000	27.50	0.28
22000	24.69	0.27
23000	22.01	0.20
24000	18.22	0.26
25000	13.82	0.47
26000	8.79	1.15
27000	3.89	3.56
28000	1.08	11.94
29000	0.64	24.55
29500	0.67	18.37
30000	0.68	17.25
30500	0.67	18.14
31000	0.66	20.40
31500	0.65	23.98
32000	0.64	27.00
32500	0.63	29.80
33000	0.60	30.36
33500	0.56	29.42
34000	0.51	27.22
34500	0.47	26.18
35000	0.44	25.75
35500	0.43	26.43
36000	0.49	27.16
36500	0.58	27.78
37000	0.68	29.37
37500	0.76	36.40
38000	0.85	27.93
38500	0.97	21.13
39000	1.11	20.03

Typical Performance Curves

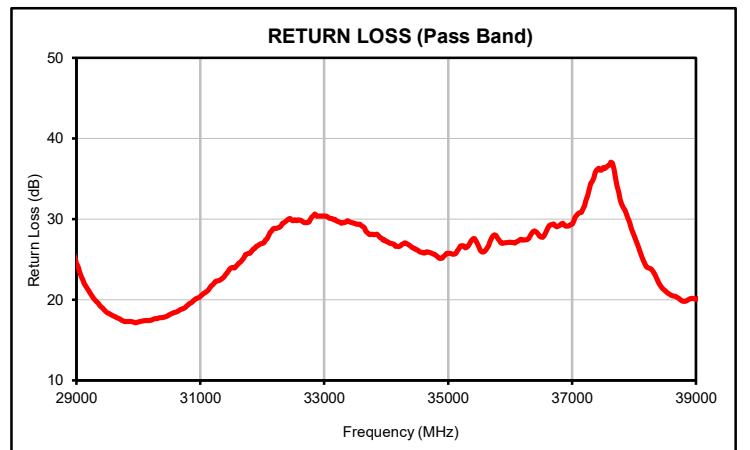
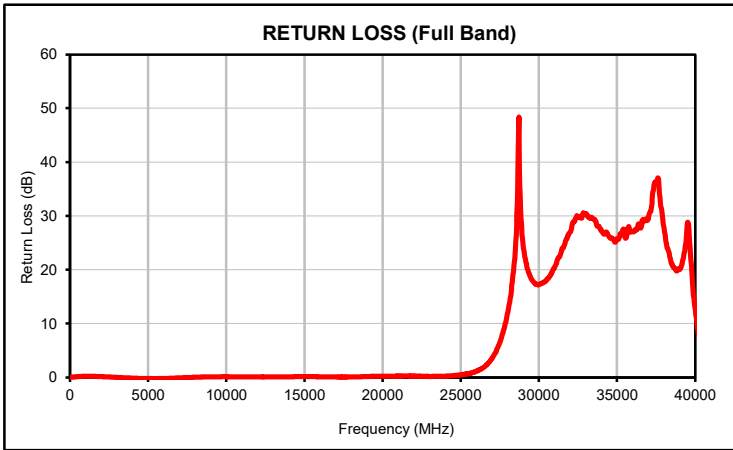
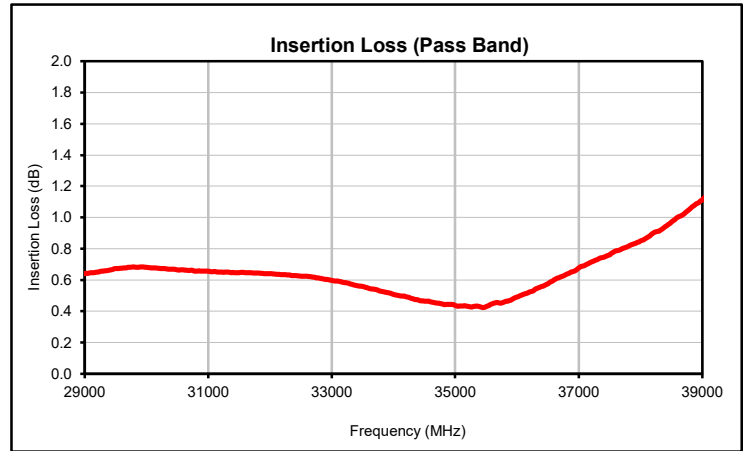
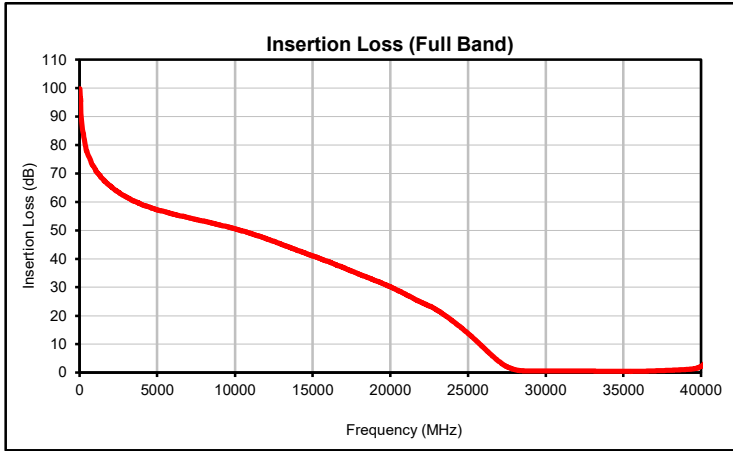

Outline Dimensions

NL1008C-6

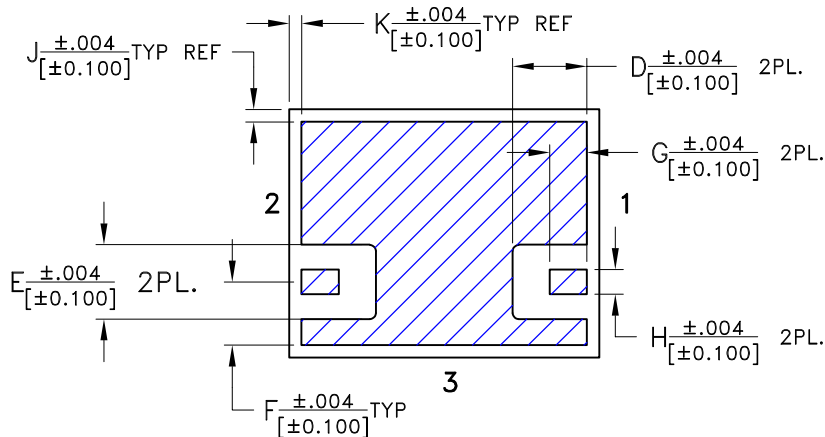
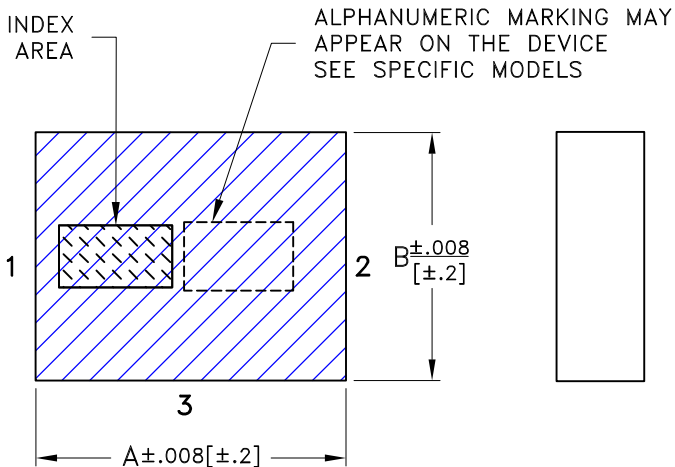

DENOTES METALLIZATION

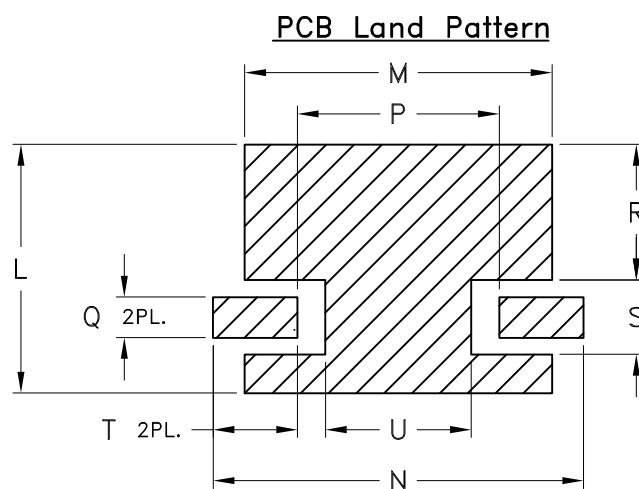

Suggested Layout,
Tolerance to be within $\pm .002$

CASE#	A	B	C	D	E	F	G	H	J	K	L	M	N
NL1008C-6	.098 (2.50)	.079 (2.00)	.028 (.705)	.024 (.60)	.024 (.60)	.020 (.51)	.012 (.30)	.008 (.20)	.004 (.10)	.004 (.10)	.079 (2.0)	.098 (2.5)	.118 (3.0)

CASE #	P	Q	R	S	T	U	WT, GRAM
NL1008C-6	.064 (1.63)	.013 (.3)	.043 (1.09)	.024 (.60)	.027 (.7)	.046 (1.2)	.019

Dimensions are in inches (mm). Tolerances: 2 Pl. $\pm .01$; 3 Pl. $\pm .005$

Notes:

1. Open style, ceramic base.
2. Termination finish:
For RoHS Case Styles: Tin plate over Nickel plate. All models, (+) suffix.
For RoHS-5 Case Styles: Tin-Lead plate. All models, no (+) suffix.
3. Pad tolerance is non-cumulative. Minimum spacing between each pad is .004.
4. Line width should be designed to match 50Ω characteristic depending on PCB material and thickness.

Mini-Circuits®
ISO 9001 ISO 14001 CERTIFIED

ALL NEW
 minicircuits.com

P.O. Box 350166, Brooklyn, New York 11235-0003 (718) 934-4500 Fax (718) 332-4661 For detailed performance specs & shopping online see Mini-Circuits web site



The Design Engineers Search Engine Provides ACTUAL Data Instantly From MINI-CIRCUITS At: www.minicircuits.com

RF/IF MICROWAVE COMPONENTS

THIRD ANGLE PROJECTION

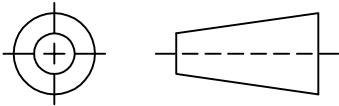

REVISIONS

REV	ECN No.	DESCRIPTION	DATE	DR	AUTH
OR	ECO-007756	NEW RELEASE	05/12/21	ITG	IL

SUGGESTED MOUNTING CONFIGURATION
FOR NL1008C-6 CASE STYLE

SOLDER MASK BORDER
(SEE NOTE 2)

PACKAGE OUTLINE

COPLANAR WAVEGUIDE:
.0091±.001 TRACE WIDTH &
.0079±.001 GAP, 2 PL.

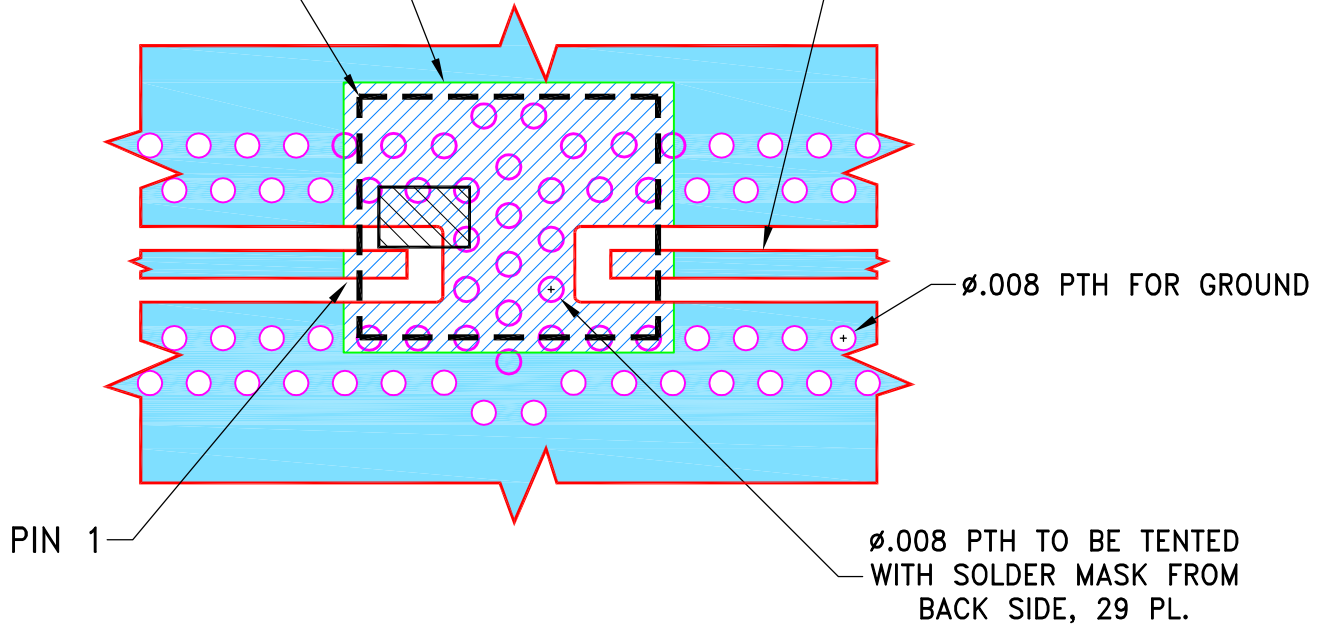

NOTES:

1. COPLANAR WAVEGUIDE PARAMETERS ARE SHOWN FOR MEGTRON-7 R5785(N); DIELECTRIC THICKNESS: .0049±.001; CLOTH STYLE: 2116; COPPER: HVLP/HVLP. FOR OTHER MATERIALS LINE WIDTH & GAP MAY NEED TO BE MODIFIED.
2. SOLDER MASK OPENING FOR COMPONENT SOLDERING HAS BEEN INCREASED AGAINST PCB LAND PATTERN RECOMMENDATIONS PER NL1008C-6 AND CAN BE DEVIATED FROM THIS DRAWING TO COMPLY WITH CUSTOMERS' DESIGN RULES.
3. BOTTOM SIDE OF THE PCB IS CONTINUOUS GROUND PLANE.

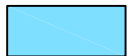

DENOTES PCB COPPER LAYOUT WITH SMOBC (SOLDER MASK OVER BARE COPPER).



DENOTES COPPER LAND PATTERN FREE OF SOLDER MASK.

UNLESS OTHERWISE SPECIFIED	INITIALS		DATE
DIMENSIONS ARE IN INCHES	DRAWN	ITG	05/12/21
TOLERANCES ON:	CHECKED	GF	05/12/21
2 PL DECIMALS ±	APPROVED	IL	05/12/21
3 PL DECIMALS ± .005			
ANGLES ±			
FRACTIONS ±			



Mini-Circuits®

13 Neptune Avenue
Brooklyn NY 11235

PL, NL1008C-6, TB-BFCQ-XXXX+

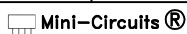

THIS DOCUMENT AND ITS CONTENTS ARE THE PROPERTY OF MINI-CIRCUITS. EXCEPT FOR USE EXPRESSLY GRANTED, IN WRITING, TO ITS VENDORS, VENDEE AND THE UNITED STATES GOVERNMENT, MINI-CIRCUITS RESERVES ALL PROPRIETARY DESIGN, USE, MANUFACTURING AND REPRODUCTION RIGHTS THERETO. THESE CONTENTS SHALL NOT BE USED, DUPLICATED OR DISCLOSED TO ANY OUTSIDE PARTY, IN WHOLE OR IN PART, WITHOUT WRITTEN PERMISSION OF MINI-CIRCUITS.

SIZE	CODE IDENT	DRAWING NO:	REV:
A	15542	98-PL-707	OR
FILE:	98PL707	SCALE: 15:1	SHEET: 1 OF 1

Evaluation Board and Circuit

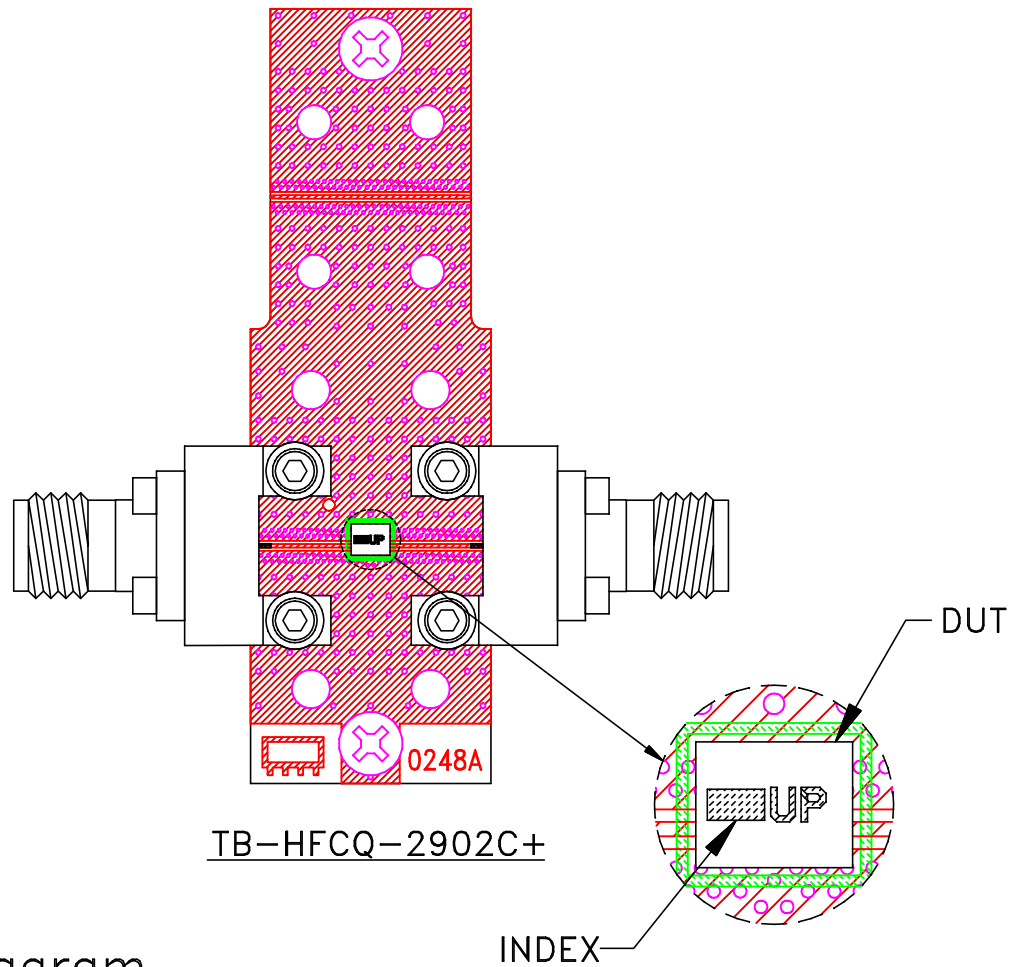

Schematic diagram

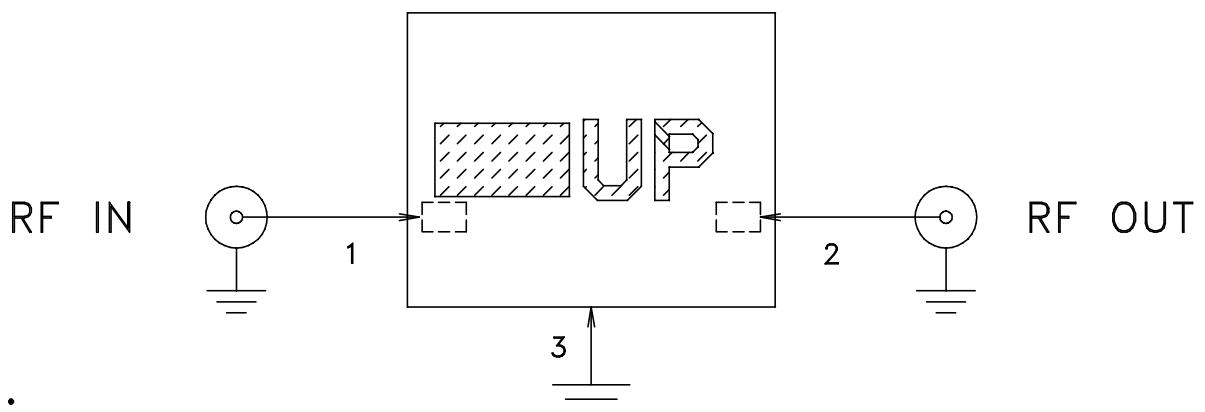

Notes:

1. 50 Ohm 1.85 Female connectors.
2. PCB Material: Megtron 7(N) or equivalent,
Dielectric Constant=3.4, Thickness=.005 inch.

 Mini-Circuits®



All Mini-Circuits products are manufactured under exacting quality assurance and control standards, and are capable of meeting published specifications after being subjected to any or all of the following physical and environmental test.

Specification	Test/Inspection Condition	Reference/Spec
Operating Temperature	-55° to 125° C Ambient Environment	Individual Model Data Sheet
Storage Temperature	-55° to 125° C Ambient Environment	Individual Model Data Sheet
Thermal Cycling	-55 to 125°C, 100 cycles, Dwell Time 15 minutes.	MIL-STD-202, Method 107, Condition A-3
Mechanical Shock	50g, 11ms half-sine, 18 shocks applied each to 3 axes	MIL-STD-202 Method 213, Condition A
Vibration	10-2000Hz sine, 20g, 12 cycles applied each to 3 axes	MIL-STD-202, Method 204, Condition D
Constant Acceleration	30Kg, Y1 Direction	MIL-STD-883, Method 2001, Condition E
Humidity	85°C, 90-95% Relative Humidity, 250hours	
Solderability	10X / 30X Magnification	J-STD-002C Test S, J-STD-002C Test S1
High Temp Storage	125°C, 250 hours	