

Ceramic High Pass Filter

HFCW-1132+

50Ω 13000 to 20000 MHz

The Big Deal

- Very good rejection, 36 dB typical
- Small size 0603 (0.063" X 0.032" X 0.024")
- Good Power handling, 2.5W
- Ceramic construction



Generic photo used for illustration purposes only
CASE STYLE: JC0603C

Product Overview

HFCW-1132+ is a high pass filter with passband from 13000 MHz to 20000 MHz supporting a variety of applications. This model provides good insertion loss over a wide band due to strategically constructed layout. Housed in a tiny 0603 ceramic form factor with wraparound terminations, the filter is ideal for dense PCB layouts with minimal performance variation due to parasitics.

Key Features

Feature	Advantages
Small size, 0603 (0.063" X 0.032" X 0.024")	Accommodates tight space requirements for dense PCB layouts.
Wrap around termination	Provides excellent solderability and easy visual inspection capability.
LTCC construction	Provides a rugged package that is well suited for tough environments including high humidity and high temperature extremes.
Ultra-wide pass band	This filter has a very wide passband from 13 GHz to 20 GHz.

Notes

- A. Performance and quality attributes and conditions not expressly stated in this specification document are intended to be excluded and do not form a part of this specification document.
B. Electrical specifications and performance data contained in this specification document are based on Mini-Circuit's applicable established test performance criteria and measurement instructions.
C. The parts covered by this specification document are subject to Mini-Circuits standard limited warranty and terms and conditions (collectively, "Standard Terms"); Purchasers of this part are entitled to the rights and benefits contained therein. For a full statement of the Standard Terms and the exclusive rights and remedies thereunder, please visit Mini-Circuits' website at www.minicircuits.com/MCLStore/terms.jsp



Ceramic High Pass Filter

HFCW-1132+

50Ω 13000 to 20000 MHz



Generic photo used for illustration purposes only
CASE STYLE: JC0603C

+RoHS Compliant

The +Suffix identifies RoHS Compliance. See our web site for RoHS Compliance methodologies and qualifications

Features

- Very good rejection, 36 dB typ.
- Small size 0603 (0.063" X 0.032" X 0.024")
- Temperature stable
- LTCC construction

Applications

- Test and measurements
- Military applications
- Telecommunications and broadband wireless systems

Functional Schematic

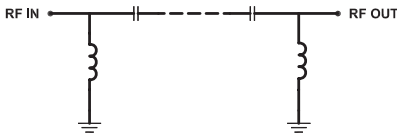

Electrical Specifications^(1,2) at 25°C

Parameter		F#	Frequency (MHz)	Min.	Typ.	Max.	Unit
Stop Band	Rejection Loss	DC-F1	DC - 7000	30	36	-	dB
		F1-F2	7000 - 9500	23	36	-	dB
	Freq. Cut-Off	F3*	11300	-	3	-	dB
Pass Band	Insertion Loss	F4-F5	13000 - 14000	-	2.0	-	dB
		F5-F6	14000 - 18000	-	0.9	1.7	dB
	F6-F7	18000 - 20000	-	1.5	-	dB	
	Return Loss	F4-F5	13000 - 14000	-	8	-	dB
		F5-F6	14000 - 18000	-	10	-	dB
F6-F7		18000 - 20000	-	8	-	dB	

1 This component is not intended to act as a DC block. Please consult with Mini-Circuits for further details

2 Measured on Mini-Circuits Characterization Test Board TB-HFCW-1132+

* Typically, a ±5% frequency deviation from the stated value may occur on a unit-to-unit basis.

Maximum Ratings

Operating Temperature	-55°C to 125°C
Storage Temperature	-55°C to 125°C
RF Power Input*	2.5W @ 25°C

* Passband rating, derate linearly to 0.6W at 125°C ambient
Permanent damage may occur if any of these limits are exceeded.

Typical Frequency Response

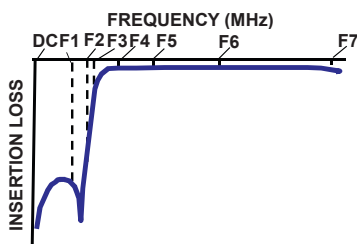

Typical Performance Data at 25°C

Frequency (MHz)	Insertion Loss (dB)	Return Loss (dB)
10	67.26	0.09
100	65.40	0.09
500	50.98	0.14
2000	39.83	0.14
4000	36.01	0.07
7000	39.29	0.12
9300	36.48	0.38
9500	33.24	0.42
10275	20.01	0.76
10750	10.15	1.96
11300	3.17	7.25
12000	2.11	8.73
13000	1.01	23.05
14000	0.83	18.80
15000	0.76	18.19
16000	0.76	16.01
17000	0.74	13.89
18000	0.69	13.45
20000	0.60	16.25
24000	2.35	5.22

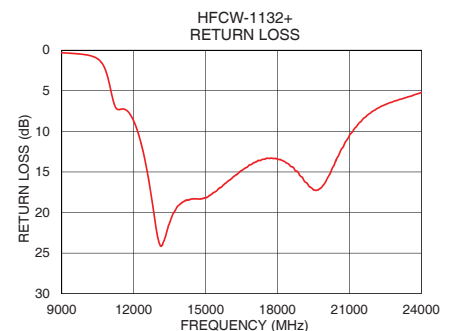
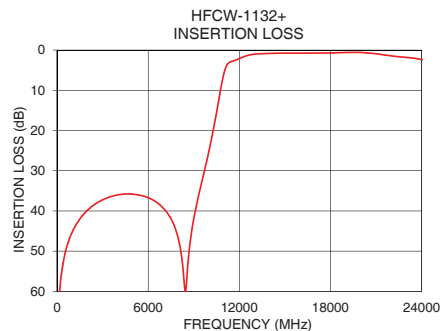
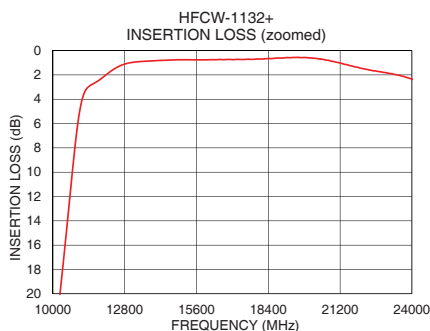

Notes

- Performance and quality attributes and conditions not expressly stated in this specification document are intended to be excluded and do not form a part of this specification document.
- Electrical specifications and performance data contained in this specification document are based on Mini-Circuits' applicable established test performance criteria and measurement instructions.
- The parts covered by this specification document are subject to Mini-Circuits standard limited warranty and terms and conditions (collectively, "Standard Terms"); Purchasers of this part are entitled to the rights and benefits contained therein. For a full statement of the Standard Terms and the exclusive rights and remedies thereunder, please visit Mini-Circuits' website at www.minicircuits.com/MCLStore/terms.jsp



www.minicircuits.com P.O. Box 350166, Brooklyn, NY 11235-0003 (718) 934-4500 sales@minicircuits.com

REV. OR
ECO-008648
HFCW-1132+
EDU3967
URJ
210713
Page 2 of 3

Pad Connections

INPUT	1
OUTPUT	3
GROUND	2,4,5,6

Product Marking: U

Demo Board MCL P/N: TB-HFCW-1132+
Suggested PCB Layout (PL-704)

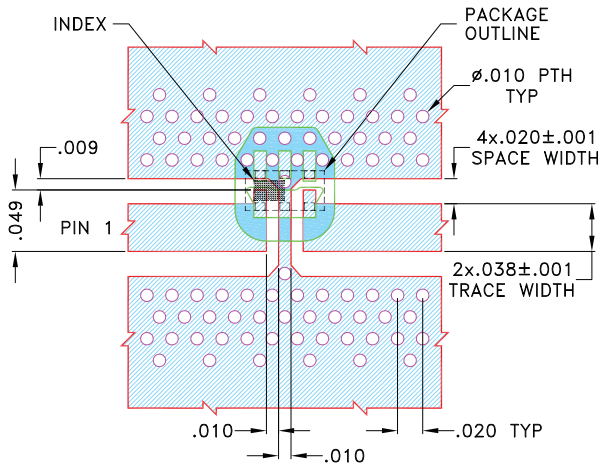

NOTES:

- COPLANAR WAVEGUIDE PARAMETERS ARE SHOWN FOR ROGERS (RO3003) WITH DIELECTRIC THICKNESS .020±.001 COPPER: 1/2 Oz. EACH SIDE. FOR OTHER MATERIALS TRACE WIDTH AND GAP MAY NEED TO BE MODIFIED.
 - BOTTOM SIDE OF THE PCB IS CONTINUOUS GROUND PLANE.
- DENOTES PCB COPPER PATTERN WITH SMOBC (SOLDER MASK OVER BARE COPPER)
 DENOTES PCB COPPER PATTERN FREE OF SOLDERMASK

Outline Drawing

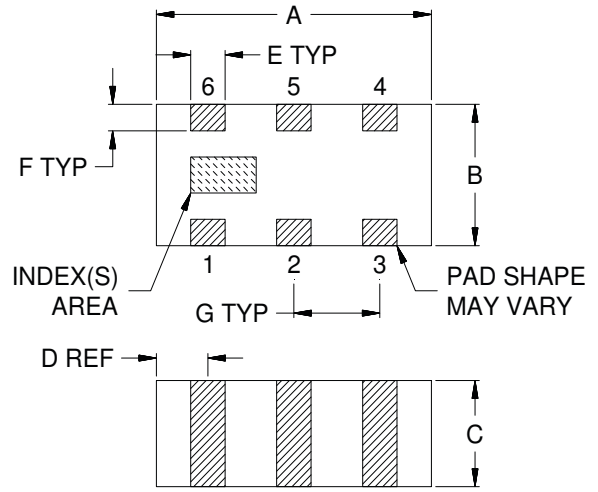

Outline Dimensions (inch)

A	B	C	D	E	F	G	Wt.
.063	.032	.024	.012	.008	.006	.020	grams
1.60	0.80	0.60	0.30	0.20	0.15	0.50	.005

Note: Please refer to case style drawing for details.

Notes

- A. Performance and quality attributes and conditions not expressly stated in this specification document are intended to be excluded and do not form a part of this specification document.
 B. Electrical specifications and performance data contained in this specification document are based on Mini-Circuit's applicable established test performance criteria and measurement instructions.
 C. The parts covered by this specification document are subject to Mini-Circuits standard limited warranty and terms and conditions (collectively, "Standard Terms"); Purchasers of this part are entitled to the rights and benefits contained therein. For a full statement of the Standard Terms and the exclusive rights and remedies thereunder, please visit Mini-Circuits' website at www.minicircuits.com/MCLStore/terms.jsp

Typical Performance Data

FREQ. (MHz)	INSERTION LOSS			INPUT RETURN LOSS			OUTPUT RETURN LOSS		
	(dB)			(dB)			(dB)		
	@-55°C	@+25°C	@+125°C	@-55°C	@+25°C	@+125°C	@-55°C	@+25°C	@+125°C
10	62.73	63.66	77.19	0.09	0.10	0.12	0.07	0.09	0.10
30	73.57	72.47	74.11	0.10	0.11	0.14	0.10	0.11	0.13
50	70.80	69.97	70.94	0.08	0.10	0.12	0.10	0.12	0.13
100	62.87	62.55	62.47	0.07	0.09	0.12	0.11	0.14	0.16
150	61.21	60.98	61.06	0.07	0.09	0.13	0.11	0.14	0.16
350	55.11	55.08	55.12	0.09	0.12	0.17	0.12	0.16	0.19
450	52.43	52.45	52.50	0.11	0.14	0.19	0.13	0.17	0.20
550	50.55	50.56	50.60	0.12	0.16	0.21	0.13	0.17	0.20
750	47.76	47.80	47.83	0.15	0.19	0.24	0.13	0.18	0.21
950	45.75	45.79	45.80	0.17	0.21	0.26	0.13	0.18	0.22
1150	44.15	44.19	44.21	0.17	0.22	0.27	0.13	0.18	0.22
1300	43.16	43.19	43.21	0.18	0.23	0.28	0.13	0.18	0.22
1700	41.07	41.10	41.11	0.17	0.23	0.28	0.13	0.18	0.22
2000	39.88	39.91	39.92	0.16	0.22	0.27	0.13	0.19	0.23
2500	38.38	38.42	38.43	0.15	0.21	0.26	0.12	0.18	0.22
3000	37.29	37.35	37.37	0.15	0.22	0.27	0.10	0.17	0.21
3500	36.51	36.60	36.63	0.14	0.21	0.27	0.07	0.15	0.19
4000	35.97	36.10	36.15	0.12	0.20	0.27	0.05	0.13	0.18
4500	35.71	35.87	35.97	0.10	0.19	0.26	0.04	0.12	0.18
5000	35.76	35.95	36.07	0.09	0.19	0.26	0.04	0.14	0.20
5500	36.05	36.26	36.40	0.09	0.19	0.27	0.05	0.14	0.20
6000	36.63	36.84	37.01	0.08	0.19	0.27	0.03	0.13	0.20
6500	37.55	37.79	37.99	0.08	0.19	0.28	0.01	0.12	0.19
7000	39.08	39.39	39.65	0.08	0.20	0.29	0.02	0.13	0.21
7500	41.59	42.05	42.46	0.10	0.22	0.32	0.05	0.16	0.24
8000	45.97	46.85	47.70	0.12	0.25	0.36	0.07	0.19	0.28
8500	58.89	57.30	54.93	0.15	0.29	0.42	0.09	0.23	0.33
9000	43.24	41.83	40.53	0.17	0.34	0.48	0.12	0.28	0.39
9500	34.29	33.13	31.98	0.22	0.42	0.58	0.20	0.39	0.54
9700	31.18	29.95	28.73	0.25	0.47	0.65	0.26	0.48	0.64
10275	21.69	20.00	18.40	0.49	0.80	1.09	0.68	1.05	1.42
10500	17.38	15.49	13.73	0.71	1.15	1.60	1.09	1.69	2.38
10750	12.18	10.22	8.57	1.30	2.10	3.03	2.19	3.54	5.43
11300	3.45	3.31	3.32	6.25	7.04	7.33	13.98	13.75	11.38
11700	2.57	2.67	2.70	6.68	7.30	7.92	7.84	7.99	8.20
12000	2.16	2.18	2.16	7.46	8.65	9.96	7.61	8.59	9.57
12500	1.32	1.40	1.44	12.01	14.29	17.36	11.45	13.35	15.47
13000	0.87	1.04	1.16	22.00	24.77	24.39	19.62	21.50	21.68
13200	0.78	0.96	1.10	25.18	24.77	21.95	22.45	22.58	21.12
13400	0.73	0.93	1.06	23.50	21.87	19.89	22.58	21.79	20.20
13600	0.70	0.92	1.05	21.02	19.71	18.68	21.63	20.80	19.88
13800	0.69	0.90	1.04	19.37	18.48	17.97	20.95	20.26	19.93
14000	0.68	0.88	1.01	18.43	17.94	17.81	20.40	20.18	20.33
14200	0.64	0.84	0.97	18.15	17.79	17.85	20.58	20.60	21.15
14400	0.63	0.83	0.96	17.82	17.61	17.76	21.44	21.57	22.64
14600	0.61	0.82	0.95	17.53	17.28	17.56	22.27	22.41	23.88
14800	0.61	0.81	0.93	17.39	17.10	17.47	23.10	23.32	24.69
15000	0.58	0.80	0.93	17.21	16.89	17.08	23.16	23.38	24.27
15200	0.56	0.78	0.90	16.90	16.56	16.65	22.53	22.58	22.51
15400	0.57	0.78	0.92	16.36	16.11	15.98	21.82	21.55	21.11
15600	0.58	0.79	0.94	15.80	15.54	15.33	20.78	20.23	19.80
15800	0.59	0.80	0.94	15.27	15.01	14.80	19.78	19.12	18.42
16000	0.58	0.80	0.93	14.82	14.56	14.38	18.70	18.03	17.26
16500	0.57	0.80	0.93	13.76	13.48	13.32	16.75	16.01	15.25
17000	0.54	0.76	0.91	13.01	12.87	12.60	15.40	14.66	13.93
17500	0.49	0.73	0.88	12.56	12.54	12.26	14.10	13.72	13.04
18000	0.43	0.66	0.83	12.81	12.98	12.70	13.81	13.64	13.05
18500	0.36	0.59	0.75	14.00	14.40	14.32	14.35	14.41	13.92
19000	0.30	0.54	0.69	16.09	16.59	16.86	15.60	15.56	15.15
20000	0.27	0.51	0.71	16.38	16.24	15.40	15.07	14.65	13.62

Typical Performance Data

FREQ. (MHz)	GROUP DELAY		
	(nsec)		
	@-55°C	@+25°C	@+125°C
13000	0.16	0.15	0.14
13200	0.14	0.14	0.13
13400	0.13	0.12	0.12
13600	0.12	0.11	0.11
13800	0.11	0.10	0.10
14000	0.10	0.10	0.10
14200	0.10	0.09	0.09
14400	0.09	0.08	0.09
14600	0.09	0.08	0.08
14800	0.08	0.08	0.08
15000	0.08	0.08	0.08
15200	0.07	0.08	0.07
15400	0.07	0.07	0.07
15600	0.06	0.07	0.07
15800	0.07	0.07	0.06
16000	0.07	0.06	0.06
16200	0.06	0.05	0.06
16400	0.06	0.06	0.06
16600	0.06	0.05	0.05
16800	0.05	0.05	0.05
17000	0.05	0.05	0.05
17200	0.06	0.05	0.05
17400	0.05	0.05	0.05
17600	0.05	0.05	0.05
17800	0.05	0.05	0.05
18000	0.05	0.05	0.05
18200	0.05	0.05	0.05
18400	0.05	0.05	0.05
18600	0.05	0.05	0.05
18800	0.05	0.05	0.05
19000	0.05	0.05	0.05
19200	0.05	0.05	0.05
19300	0.05	0.05	0.05
19400	0.05	0.05	0.05
19500	0.05	0.05	0.05
19600	0.05	0.05	0.05
19700	0.05	0.05	0.05
19800	0.05	0.05	0.05
19900	0.05	0.05	0.05
20000	0.05	0.04	0.04

Typical Performance Curves

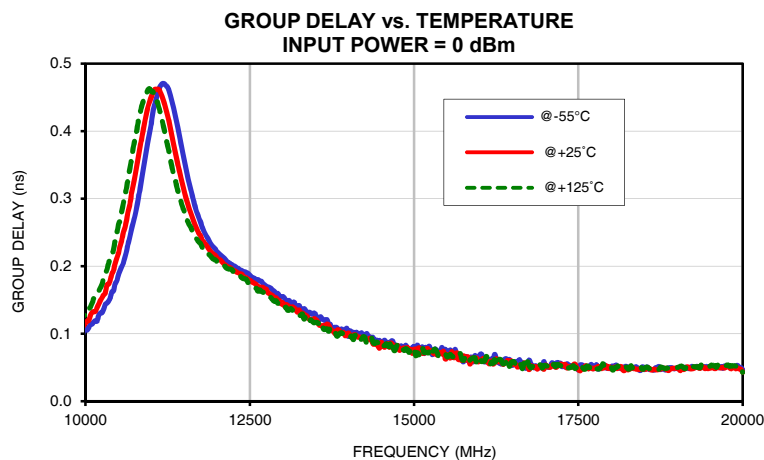
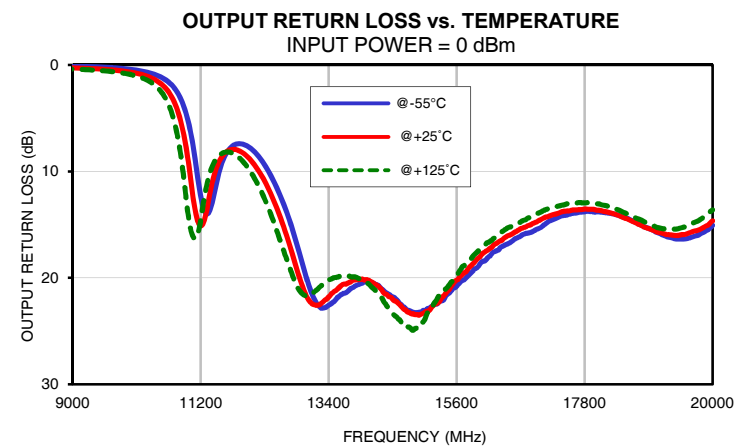
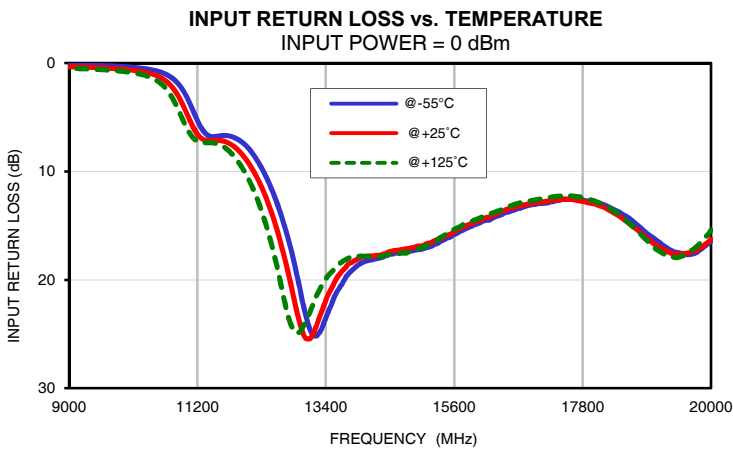
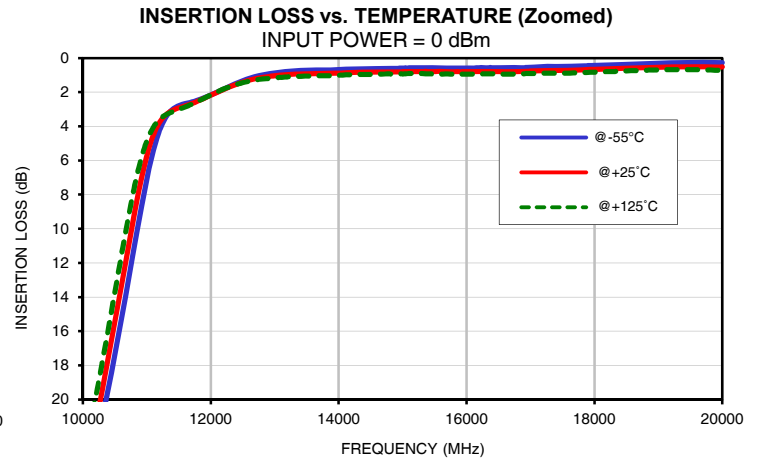
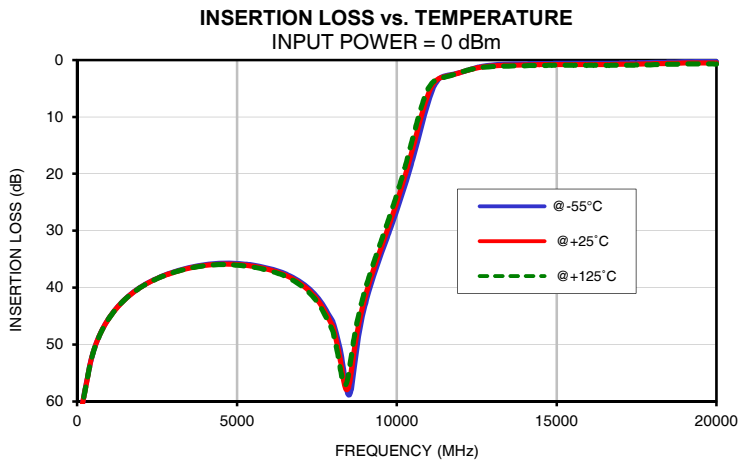

Case Style

JC

Outline Dimensions

JC0603C

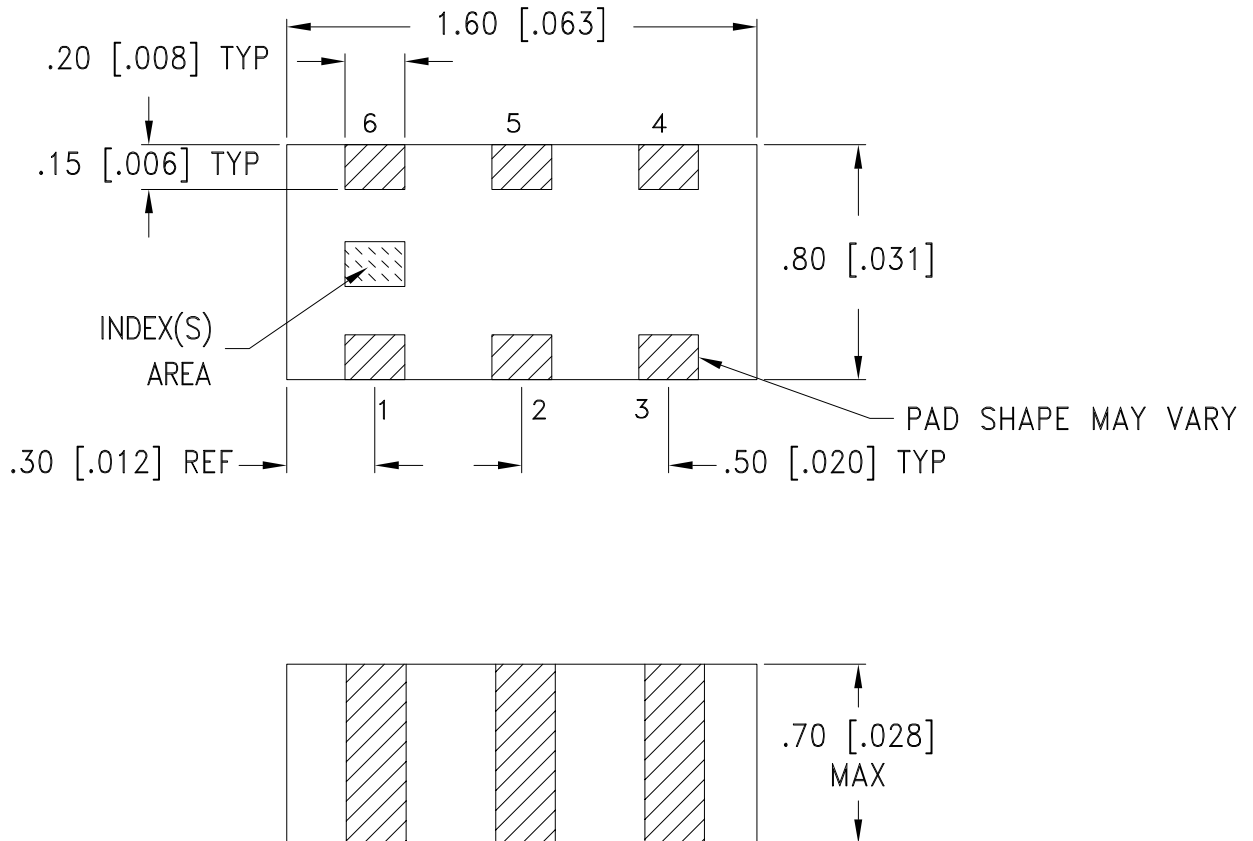

Weight: .005 grams

Dimensions are in mm [inch]. Tolerances: ± 0.13 mm

Notes:

1. Open style, ceramic base.
2. Termination finish:

For RoHS Case Styles: Tin plate over Nickel plate. All models, (+) suffix.



P.O. Box 350166, Brooklyn, New York 11235-0003 (718) 934-4500 Fax (718) 332-4661 For detailed performance specs & shopping online see Mini-Circuits web site



The Design Engineers Search Engine Provides ACTUAL Data Instantly From MINI-CIRCUITS At: www.minicircuits.com

RF/IF MICROWAVE COMPONENTS

Tape & Reel Packaging TR-F114

DEVICE ORIENTATION IN T&R



ILLUSTRATION 1

Applicable Case Styles	
GE0805C	JC0603C
GE0805C-1	JC0603C-4
GE0805C-1AP	JC0603C-6
GE0805C-7	
GE0805C-9	
GE0805C-10	
GE0805C-11	
GE0805C-12	



ILLUSTRATION 2

Applicable Case Styles	
GE0805C-2	JC0603C-1
GE0805C-3	JC0603C-2
GE0805C-4	JC0603C-3
GE0805C-5	JC0603C-5
GE0805C-6	JC0603C-7
GE0805C-8	
GE0805C-15	

Tape Width, mm	Device Cavity Pitch, mm	Reel Size, inches	Devices per Reel	
8	4	7	Small quantity standards (see note)	20
				50
				100
				200
				500
			Standard	1000
			Standard	4000

Note: Please Consult individual model data sheet to determine device per reel availability.

Mini-Circuits carrier tape materials provide protection from ESD (Electro-Static Discharge) during handling and transportation. Tapes are static dissipative and comply with industry standards EIA-481/EIA-541.

Go to: www.minicircuits.com/pages/pdfs/tape.pdf



INTERNET <http://www.minicircuits.com>

P.O. Box 350166, Brooklyn, New York 11235-0003 (718) 934-4500 Fax (718) 332-4661

Distribution Centers NORTH AMERICA 800-654-7949 • 417-335-5935 • Fax 417-335-5945 • EUROPE 44-1252-832600 • Fax 44-1252-837010

Mini-Circuits ISO 9001 & ISO 14001 Certified

THIRD ANGLE PROJECTION

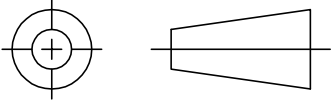

REVISIONS

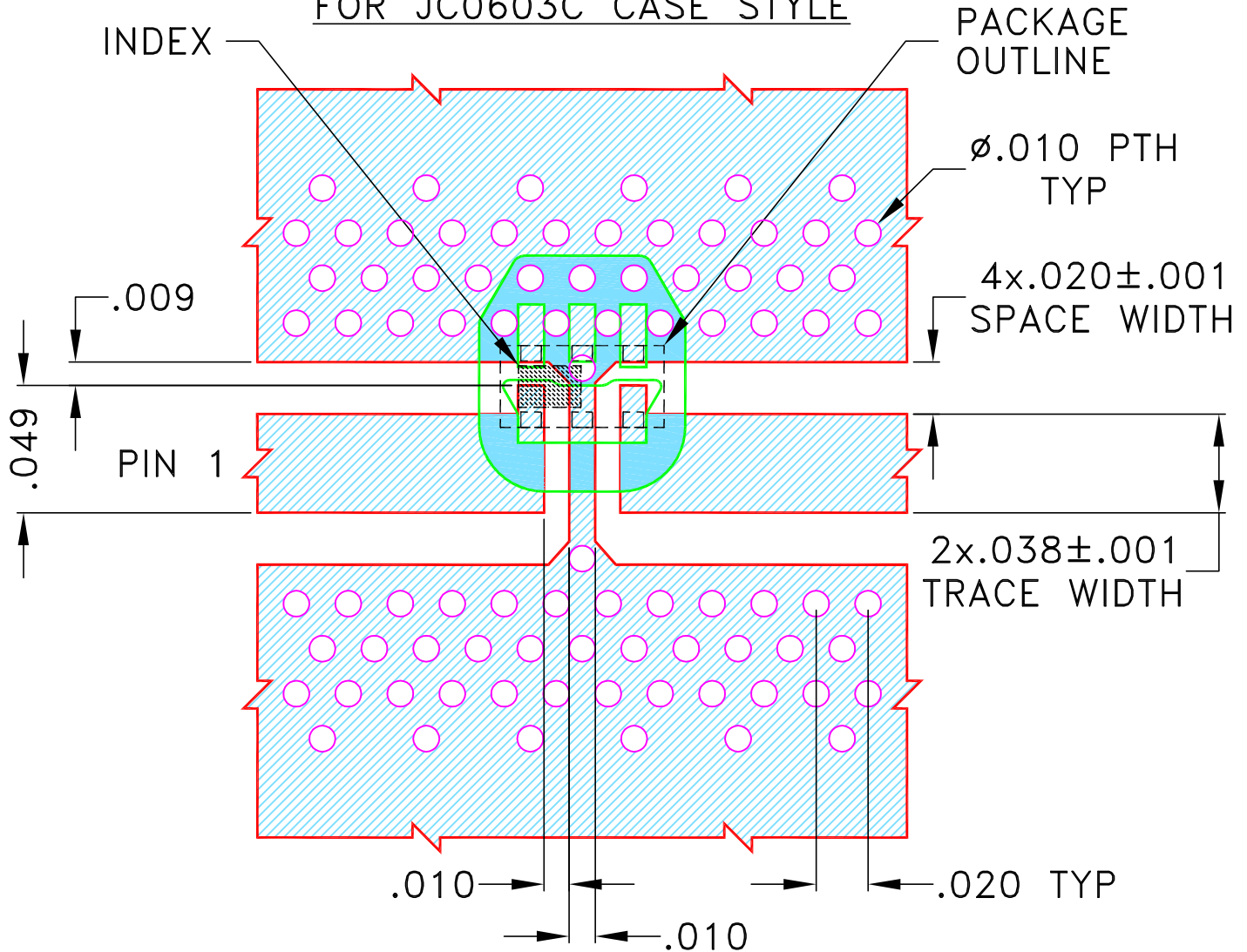

REV	ECN No.	DESCRIPTION	DATE	DR	AUTH
OR	ECO-006344	NEW RELEASE	FEB 21	KKR	VC

SUGGESTED MOUNTING CONFIGURATION
FOR JC0603C CASE STYLE



NOTES:

1. COPLANAR WAVEGUIDE PARAMETERS ARE SHOWN FOR ROGERS (R03003) WITH DIELECTRIC THICKNESS $.020 \pm .001$ COPPER: 1/2 Oz. EACH SIDE. FOR OTHER MATERIALS TRACE WIDTH AND GAP MAY NEED TO BE MODIFIED.
2. BOTTOM SIDE OF THE PCB IS CONTINUOUS GROUND PLANE.

 DENOTES PCB COPPER PATTERN WITH SMOBC (SOLDER MASK OVER BARE COPPER)
 DENOTES PCB COPPER PATTERN FREE OF SOLDERMASK

UNLESS OTHERWISE SPECIFIED	INITIALS	DATE
DIMENSIONS ARE IN INCHES	DRAWN KKR	17 FEB 21
TOLERANCES ON:	CHECKED DDR	17 FEB 21
2 PL DECIMALS ±	APPROVED RV	17 FEB 21
3 PL DECIMALS ± .005		
ANGLES ±		
FRACTIONS ±		

 **Mini-Circuits®** 13 Neptune Avenue
Brooklyn NY 11235

PL DWG, JC0603C C.S, 50 OHM, HFCW

Mini-Circuits®		SIZE	CODE IDENT	DRAWING NO:	REV:
THIS DOCUMENT AND ITS CONTENTS ARE THE PROPERTY OF MINI-CIRCUITS. EXCEPT FOR USE EXPRESSLY GRANTED, IN WRITING, TO ITS VENDORS, VENDEE AND THE UNITED STATES GOVERNMENT, MINI-CIRCUITS RESERVES ALL PROPRIETARY DESIGN, USE, MANUFACTURING AND REPRODUCTION RIGHTS THERETO. THESE CONTENTS SHALL NOT BE USED, DUPLICATED OR DISCLOSED TO ANY OUTSIDE PARTY, IN WHOLE OR IN PART, WITHOUT WRITTEN PERMISSION OF MINI-CIRCUITS.		A	15542	98-PL-704	OR
ASHEETA1.DWG REV:A DATE:01/12/95	FILE:	98PL704	SCALE:	15:1	SHEET: 1 OF 1

Evaluation Board and Circuit

TB-HFCW-1132+

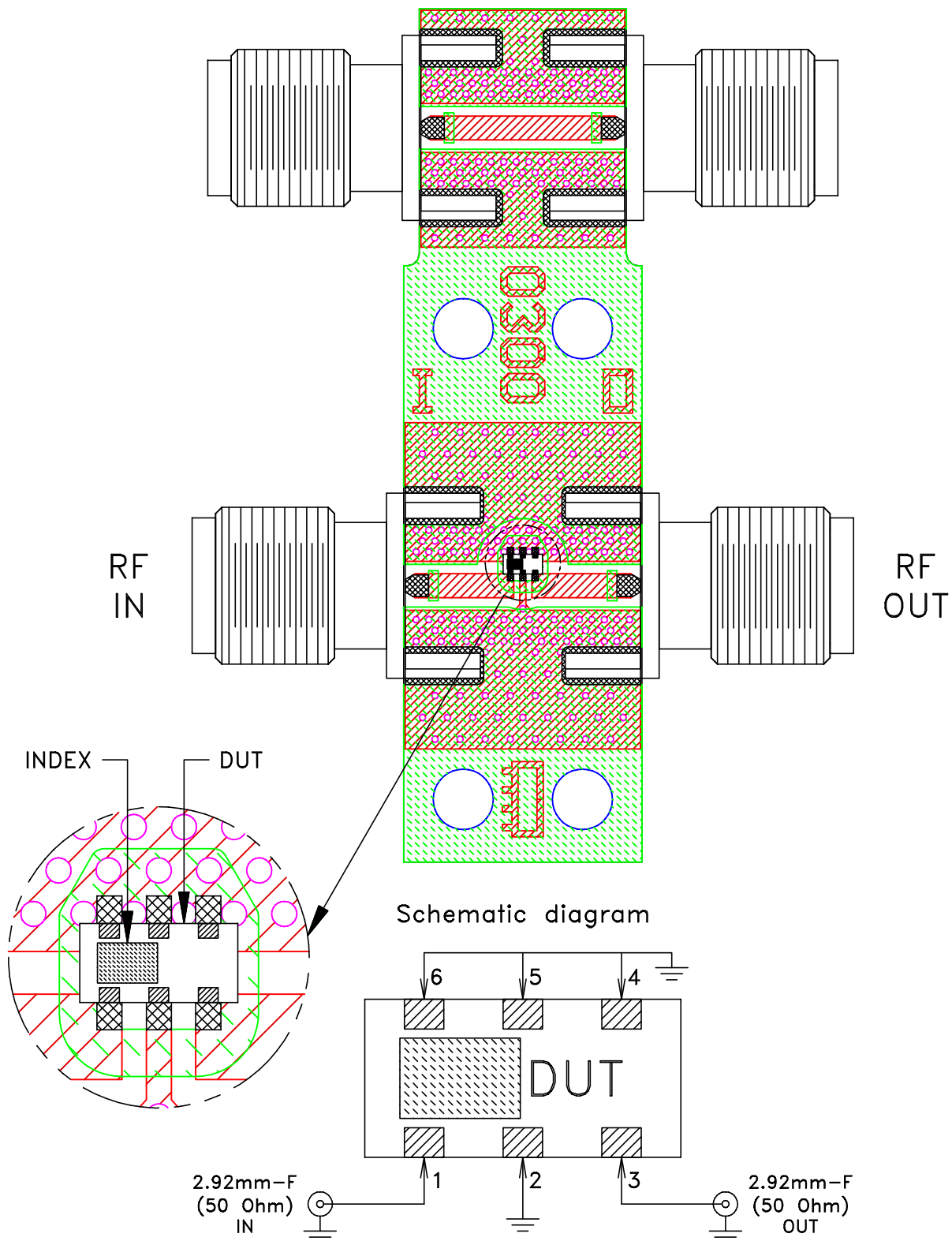

Notes:

1. PCB Material: ROGERS (R03003) OR Equivalent, Dielectric Constant= 3.48 ± 0.05
Dielectric Thickness: $.020 \pm 0.001$
2. 50 Ohm 2.92mm Female Connectors.
3. Connectors on the test board shall not be subjected to temperature greater than 200°C to avoid permanent damage to the connectors.

 **Mini-Circuits®**

All Mini-Circuits products are manufactured under exacting quality assurance and control standards, and are capable of meeting published specifications after being subjected to any or all of the following physical and environmental test.

Specification	Test/Inspection Condition	Reference/Spec
Operating Temperature	-55° to 100°C Ambient Environment	Individual Model Data Sheet
Storage Temperature	-55° to 100° C Ambient Environment	Individual Model Data Sheet
Humidity	90 to 95% RH, 240 hours, 50°C	MIL-STD-202, Method 103, Condition A, Except 50°C and end-point electrical test done within 12 hours
Solder Reflow Heat	Sn-Pb Eutetic Process: 225°C peak Pb-Free Process 245° - 250°C peak	J-STD-020, Table 4-1, 4-2 and 5-2, Figure 5-1
Solderability	10X Magnification	J-STD-002, Para 4.2.5, Test S, 95% Coverage
Vibration (High Frequency)	20g peak, 10-2000 Hz, 12 times in each of three perpendicular directions (total 36)	MIL-STD-202, Method 204, Condition D
Mechanical Shock	50g, 11 ms, 1/2-sine, 18 shocks: 3 each direction, each of 3 axes	MIL-STD-202, Method 213, Condition A