



LTCC SURFACE MOUNT

High Pass Filter

HFHK-6010+

50Ω

6600 to 17000 MHz

THE BIG DEAL

- Insertion Loss, Typ. 1.5 dB
- Stopband Rejection, Typ. 74 dB
- Passband Return Loss, Typ. 11 dB
- 1008 Surface Mount Footprint
- Power Handling: 6 W
- Shielded Construction: Prevents De-Tuning & EMI
- Protected by US Patents 11,638,370 and 11,744,057

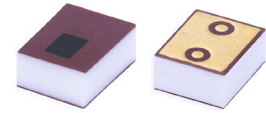

Generic photo used for illustration purposes only

APPLICATIONS

- 5G Sub- 6 GHz
- Radar, EW, ECM Defense Systems
- Test and Measurement Equipment
- Telecommunications and Broadband Wireless Systems
- WiFi 6E

FUNCTIONAL DIAGRAM

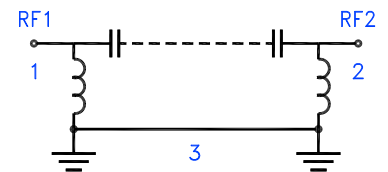

PRODUCT OVERVIEW

Mini-Circuits' HFHK-6010+ is a miniature low temperature co-fired ceramic (LTCC) high pass filter with a 6600 to 17000 MHz passband that supports a variety of applications. This model provides 1.5 dB typical insertion loss over a wide band due to its rugged monolithic construction. Housed in a small 1008 ceramic form factor, the filter is ideal for dense signal chain PCB layouts where it complements MMIC size and performance. The LTCC fabrication process assures minimal RF performance variation while delivering a product that is well suited for environmental extremes of high humidity and temperature.

KEY FEATURES

| Features | Advantages |
|--------------------------------|---|
| Wide Passband, 10.4 GHz | This filter has a very wide passband from, 6600 to 17000 MHz. |
| LTCC Construction | Provides repeatable performance in a rugged, ceramic package well suited for tough environments such as high humidity and temperature extremes. |
| Small Size, 1008 | Saves space in dense circuit board layouts and minimizes the effects of parasitics. |
| Rugged Power Handling, 6 Watts | Handles up to 6 Watts in a small 1008 package. |
| Shielded Construction | Due to the novel construction, it is immune to EMI/EMC effects with other neighboring components/ devices. |



ELECTRICAL SPECIFICATIONS^{1,2,3} AT +25°C

| Parameter | | F# | Frequency (MHz) | Min. | Typ. | Max. | Units |
|-----------|----------------------------|-------|-----------------|------|------|------|-------|
| Passband | Insertion Loss | F4-F5 | 6600 - 7900 | — | 2.3 | — | dB |
| | | F5-F6 | 7900 - 15500 | — | 1.5 | 2.1 | |
| | | F6-F7 | 15500 - 17000 | — | 2.2 | — | |
| | Return Loss | F4-F5 | 6600 - 7900 | — | 11 | — | dB |
| | | F5-F6 | 7900 - 15500 | — | 10 | — | |
| | | F6-F7 | 15500 - 17000 | — | 9 | — | |
| Stopband | Rejection | DC-F1 | DC - 1700 | 63 | 74 | — | dB |
| | | F1-F2 | 1700 - 3400 | 40 | 49 | — | |
| | | F2-F3 | 3400 - 4650 | 20 | 30 | — | |
| | Freq. Cut-Off ⁴ | Fc | 6100 | — | 3 | — | dB |

1. Tested on Evaluation Board P/N TB-HFHK-6010+ with connectors and feedline de-embedded with thru-line compensation.

2. This filter is bi-directional RF1 and RF2 ports may be interchanged. See S-Parameters for actual performance.

3. This component should not be used as a DC-block. In applications where DC voltage and/or current is present at either the input or output ports, external DC blocking capacitors are required.

4. Typical variation ±5%.

ABSOLUTE MAXIMUM RATINGS⁵

| Parameter | Ratings |
|--------------------------|-----------------|
| Operating Temperature | -55°C to +125°C |
| Storage Temperature | -55°C to +125°C |
| Input Power ⁶ | 6 W @ +25°C |

5. Permanent damage may occur if any of these limits are exceeded.

6. Power rating applies only to signals within the passband. Power rating above +25°C operating temperature decreases linearly to 1 W at +125°C.

TYPICAL FREQUENCY RESPONSE AT +25°C

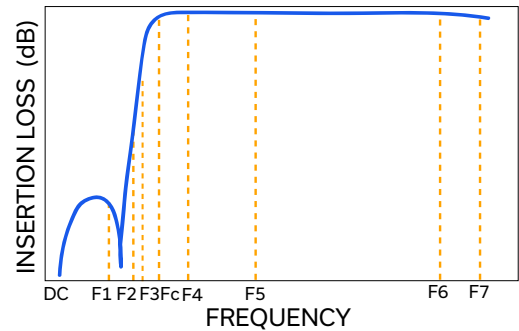



LTCC SURFACE MOUNT

High Pass Filter

HFHK-6010+

Mini-Circuits

50Ω

6600 to 17000 MHz

TYPICAL PERFORMANCE GRAPHS

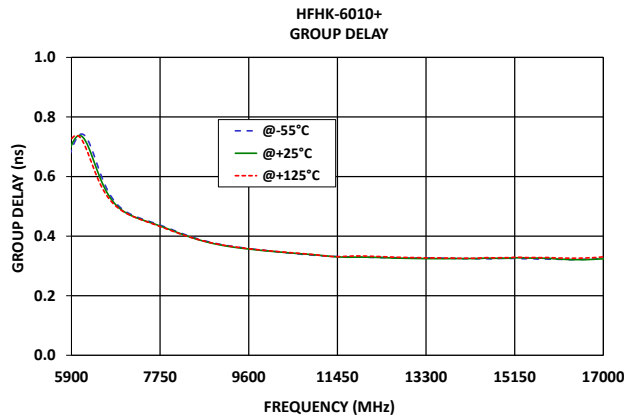
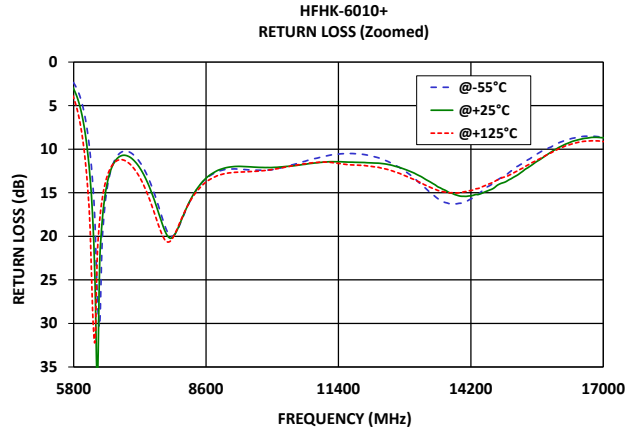
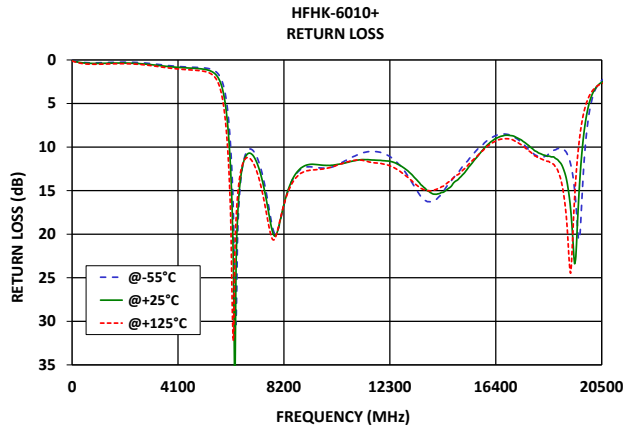
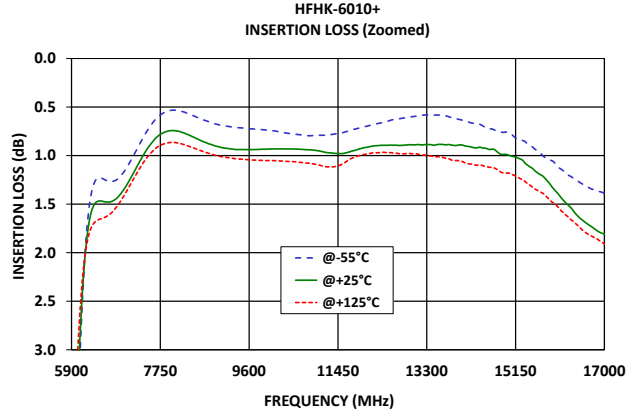
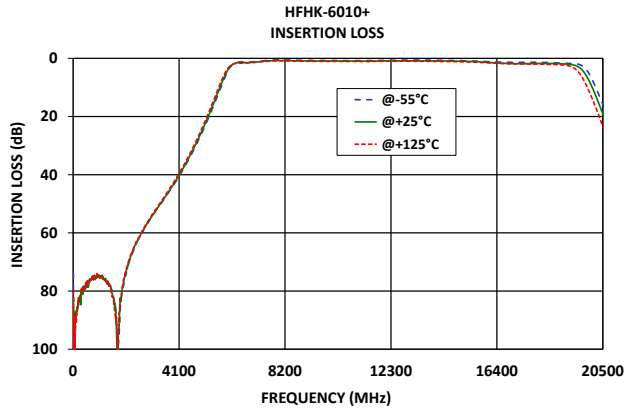



FUNCTIONAL DIAGRAM

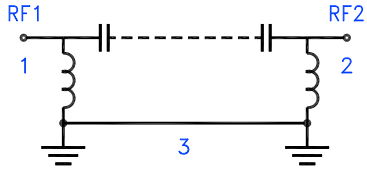
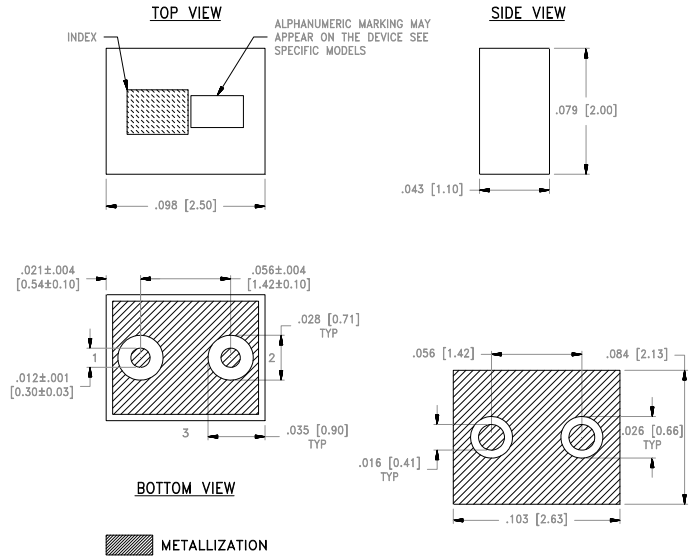

Figure 1. HFHK-6010+ Functional Diagram

PAD DESCRIPTION

| Function | Pad Number | Description |
|------------------|------------|--|
| RF1 ² | 1 | Connects to RF Input Port |
| RF2 ² | 2 | Connects to RF Output Port |
| GROUND | 3 | Connects to Ground on PCB, (See drawing PL-798) |
| NC | — | No connection, not used internally. See drawing PL-798 for connection to PCB |

CASE STYLE DRAWING



Weight: .019 grams.

Dimensions are in inches (mm). Tolerances: 2Pl. ± .01; 3Pl. ± .005

PRODUCT MARKING*: U4

*Marking may contain other features or characters for internal lot control.



SUGGESTED PCB LAYOUT (PL-798)

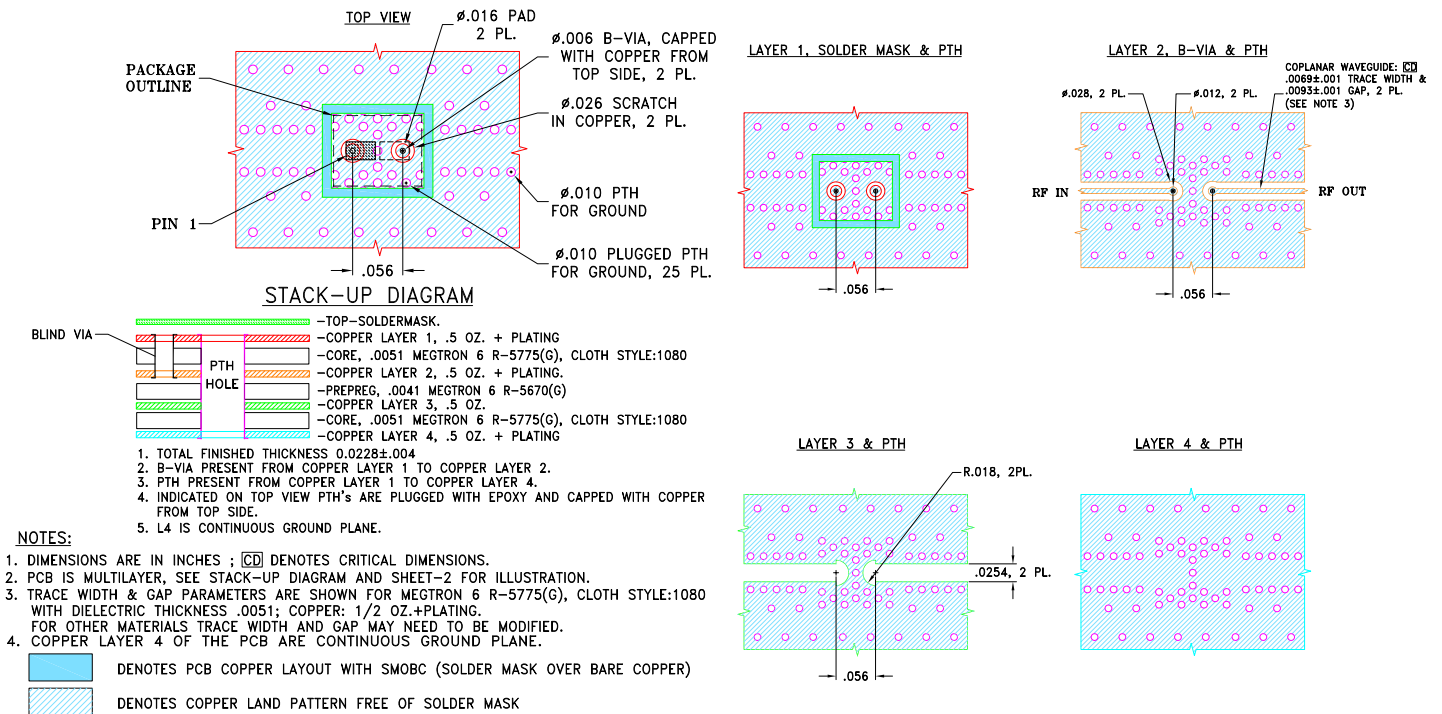

Figure 2. Suggested PCB Layout PL-798



LTCC SURFACE MOUNT

High Pass Filter

HFHK-6010+

Mini-Circuits

50Ω

6600 to 17000 MHz

ADDITIONAL DETAILED INFORMATION IS AVAILABLE ON OUR DASHBOARD.

[CLICK HERE](#)

| | |
|---------------------------------|---|
| Performance Data and Graphs | Data |
| | Graphs S-Parameter (S2P Files) Data Set (.zip file) De-embedded to device pads |
| Case Style | NL1008C-10 Lead Finish: Gold over Electroless Nickel |
| RoHS Status | Compliant |
| Tape and Reel | TR-F75 |
| Suggested Layout for PCB Design | PL-798 |
| Evaluation Board | TB-HFHK-6010+ |
| | Gerber File |
| Environmental Rating | ENV06T10 |

NOTES

- A. Performance and quality attributes and conditions not expressly stated in this specification document are intended to be excluded and do not form a part of this specification document.
- B. Electrical specifications and performance data contained in this specification document are based on Mini-Circuits' applicable established test performance criteria and measurement instructions.
- C. The parts covered by this specification document are subject to Mini-Circuits' standard limited warranty and terms and conditions (collectively, "Standard Terms"); Purchasers of this part are entitled to the rights and benefits contained therein. For a full statement of the standard terms and the exclusive rights and remedies thereunder, please visit Mini-Circuits' website at www.minicircuits.com/terms/viewterm.html



Ceramic High Pass Filter

HFHK-6010+

Typical Performance Data

| FREQ. (MHz) | INSERTION LOSS | | | INPUT RETURN LOSS | | | OUTPUT RETURN LOSS | | |
|----------------|----------------|--------|---------|-------------------|--------|---------|--------------------|--------|---------|
| | (dB) | | | (dB) | | | (dB) | | |
| | @-55°C | @+25°C | @+125°C | @-55°C | @+25°C | @+125°C | @-55°C | @+25°C | @+125°C |
| 10 | 73.87 | 82.24 | 80.00 | 0.06 | 0.09 | 0.12 | 0.07 | 0.10 | 0.13 |
| 20 | 88.61 | 92.12 | 97.07 | 0.07 | 0.11 | 0.14 | 0.08 | 0.11 | 0.14 |
| 30 | 92.66 | 96.55 | 100.61 | 0.08 | 0.11 | 0.15 | 0.08 | 0.12 | 0.15 |
| 40 | 105.97 | 94.10 | 87.69 | 0.09 | 0.12 | 0.16 | 0.09 | 0.13 | 0.16 |
| 50 | 98.99 | 106.54 | 105.38 | 0.10 | 0.13 | 0.17 | 0.10 | 0.13 | 0.17 |
| 60 | 89.59 | 87.66 | 98.63 | 0.10 | 0.14 | 0.18 | 0.10 | 0.14 | 0.18 |
| 70 | 105.00 | 91.63 | 93.34 | 0.11 | 0.15 | 0.19 | 0.11 | 0.15 | 0.19 |
| 100 | 89.72 | 87.68 | 88.71 | 0.13 | 0.17 | 0.21 | 0.13 | 0.17 | 0.22 |
| 150 | 86.85 | 87.05 | 85.55 | 0.17 | 0.20 | 0.25 | 0.16 | 0.20 | 0.26 |
| 300 | 81.00 | 84.75 | 79.58 | 0.25 | 0.29 | 0.36 | 0.24 | 0.29 | 0.37 |
| 400 | 78.46 | 80.10 | 78.37 | 0.28 | 0.33 | 0.41 | 0.27 | 0.33 | 0.42 |
| 550 | 76.95 | 77.46 | 76.45 | 0.31 | 0.37 | 0.46 | 0.29 | 0.37 | 0.47 |
| 700 | 75.43 | 75.99 | 75.65 | 0.33 | 0.39 | 0.49 | 0.31 | 0.39 | 0.49 |
| 800 | 75.92 | 75.40 | 75.49 | 0.33 | 0.40 | 0.49 | 0.32 | 0.40 | 0.49 |
| 950 | 74.66 | 75.30 | 74.61 | 0.33 | 0.40 | 0.49 | 0.32 | 0.40 | 0.49 |
| 1000 | 74.39 | 74.42 | 74.62 | 0.32 | 0.40 | 0.49 | 0.32 | 0.40 | 0.49 |
| 1100 | 75.21 | 74.86 | 75.35 | 0.32 | 0.39 | 0.48 | 0.31 | 0.39 | 0.48 |
| 1350 | 76.65 | 77.69 | 77.50 | 0.30 | 0.38 | 0.46 | 0.29 | 0.38 | 0.47 |
| 1400 | 77.53 | 77.39 | 77.83 | 0.29 | 0.37 | 0.46 | 0.29 | 0.37 | 0.46 |
| 1650 | 86.48 | 87.89 | 89.85 | 0.27 | 0.36 | 0.44 | 0.27 | 0.36 | 0.45 |
| 1700 | 94.63 | 102.80 | 98.29 | 0.27 | 0.36 | 0.44 | 0.27 | 0.36 | 0.44 |
| 1900 | 79.08 | 79.38 | 79.06 | 0.25 | 0.35 | 0.43 | 0.26 | 0.36 | 0.44 |
| 1950 | 78.27 | 77.28 | 75.96 | 0.25 | 0.35 | 0.43 | 0.26 | 0.35 | 0.44 |
| 2000 | 75.73 | 74.92 | 74.32 | 0.25 | 0.35 | 0.43 | 0.26 | 0.36 | 0.44 |
| 2100 | 71.77 | 72.15 | 70.95 | 0.25 | 0.36 | 0.43 | 0.26 | 0.36 | 0.45 |
| 2200 | 69.28 | 69.12 | 68.44 | 0.26 | 0.36 | 0.44 | 0.26 | 0.36 | 0.46 |
| 2400 | 64.59 | 64.23 | 64.28 | 0.27 | 0.39 | 0.47 | 0.28 | 0.39 | 0.48 |
| 2500 | 62.52 | 62.54 | 62.32 | 0.28 | 0.40 | 0.49 | 0.29 | 0.40 | 0.50 |
| 2700 | 59.53 | 59.18 | 58.77 | 0.32 | 0.44 | 0.53 | 0.32 | 0.44 | 0.54 |
| 2950 | 55.72 | 55.66 | 55.27 | 0.39 | 0.51 | 0.61 | 0.38 | 0.51 | 0.61 |
| 3000 | 55.12 | 54.97 | 54.52 | 0.40 | 0.52 | 0.63 | 0.39 | 0.52 | 0.63 |
| 3250 | 51.84 | 51.69 | 51.21 | 0.48 | 0.60 | 0.72 | 0.47 | 0.60 | 0.72 |
| 3400 | 49.91 | 49.73 | 49.27 | 0.53 | 0.65 | 0.79 | 0.52 | 0.65 | 0.77 |
| 3875 | 43.71 | 43.42 | 42.86 | 0.69 | 0.80 | 0.97 | 0.65 | 0.79 | 0.93 |
| 4000 | 41.99 | 41.66 | 41.03 | 0.72 | 0.83 | 1.01 | 0.68 | 0.82 | 0.97 |
| 4325 | 37.13 | 36.72 | 36.03 | 0.79 | 0.89 | 1.09 | 0.75 | 0.89 | 1.05 |
| 4650 | 31.75 | 31.23 | 30.46 | 0.83 | 0.95 | 1.16 | 0.80 | 0.95 | 1.13 |
| 4900 | 27.20 | 26.61 | 25.76 | 0.87 | 1.00 | 1.22 | 0.84 | 1.00 | 1.20 |
| 5000 | 25.28 | 24.65 | 23.77 | 0.88 | 1.02 | 1.25 | 0.87 | 1.03 | 1.24 |
| 5200 | 21.28 | 20.58 | 19.63 | 0.95 | 1.12 | 1.37 | 0.93 | 1.12 | 1.37 |
| 5400 | 17.05 | 16.29 | 15.25 | 1.08 | 1.32 | 1.63 | 1.07 | 1.31 | 1.63 |
| 5600 | 12.62 | 11.82 | 10.74 | 1.43 | 1.81 | 2.30 | 1.40 | 1.76 | 2.24 |
| 5800 | 8.12 | 7.42 | 6.46 | 2.40 | 3.11 | 4.13 | 2.29 | 2.93 | 3.87 |
| 6000 | 4.18 | 3.81 | 3.32 | 5.26 | 6.76 | 9.24 | 4.83 | 6.08 | 8.00 |
| 6100 | 2.78 | 2.64 | 2.44 | 8.32 | 10.59 | 14.74 | 7.35 | 8.98 | 11.32 |
| 6600 | 1.25 | 1.48 | 1.63 | 12.19 | 12.17 | 11.95 | 11.39 | 11.48 | 11.54 |
| 7000 | 1.16 | 1.34 | 1.41 | 10.38 | 10.95 | 11.76 | 10.62 | 11.15 | 12.19 |
| 7900 | 0.54 | 0.75 | 0.87 | 19.97 | 20.06 | 20.14 | 27.52 | 26.42 | 25.88 |
| 8500 | 0.60 | 0.82 | 0.93 | 13.93 | 13.89 | 14.25 | 14.28 | 14.23 | 14.56 |
| 9000 | 0.69 | 0.91 | 1.01 | 12.34 | 12.15 | 12.80 | 12.10 | 12.05 | 12.52 |
| 10000 | 0.74 | 0.93 | 1.05 | 12.35 | 12.10 | 12.33 | 11.85 | 11.89 | 12.07 |
| 11000 | 0.79 | 0.95 | 1.09 | 10.95 | 11.53 | 11.49 | 11.24 | 11.87 | 11.82 |
| 12000 | 0.70 | 0.92 | 0.99 | 10.67 | 11.55 | 11.91 | 11.08 | 11.89 | 12.38 |
| 13000 | 0.60 | 0.89 | 0.98 | 13.33 | 12.74 | 13.48 | 12.99 | 12.45 | 13.04 |
| 14000 | 0.63 | 0.89 | 1.05 | 16.19 | 15.40 | 14.97 | 15.45 | 14.90 | 14.25 |
| 15000 | 0.76 | 0.99 | 1.18 | 12.71 | 13.53 | 13.01 | 14.56 | 15.43 | 14.61 |
| 15500 | 0.91 | 1.13 | 1.32 | 10.89 | 11.78 | 11.52 | 12.38 | 13.33 | 13.13 |
| 16000 | 1.10 | 1.37 | 1.51 | 9.42 | 10.00 | 10.12 | 10.34 | 10.94 | 11.19 |
| 16500 | 1.28 | 1.65 | 1.75 | 8.59 | 8.88 | 9.18 | 9.07 | 9.28 | 9.68 |
| 17000 | 1.39 | 1.81 | 1.91 | 8.68 | 8.69 | 9.12 | 8.73 | 8.62 | 9.05 |

Typical Performance Data

| FREQ. (MHz) | GROUP DELAY | | |
|--------------------|-------------|--------|---------|
| | (nsec) | | |
| | @-55°C | @+25°C | @+125°C |
| 6600 | 0.57 | 0.56 | 0.55 |
| 6650 | 0.56 | 0.54 | 0.53 |
| 6700 | 0.54 | 0.53 | 0.52 |
| 6750 | 0.53 | 0.52 | 0.51 |
| 6800 | 0.52 | 0.51 | 0.50 |
| 6850 | 0.51 | 0.50 | 0.50 |
| 6900 | 0.50 | 0.49 | 0.49 |
| 6950 | 0.49 | 0.49 | 0.49 |
| 7000 | 0.49 | 0.48 | 0.48 |
| 7050 | 0.48 | 0.48 | 0.48 |
| 7100 | 0.48 | 0.47 | 0.47 |
| 7150 | 0.47 | 0.47 | 0.47 |
| 7200 | 0.47 | 0.47 | 0.46 |
| 7250 | 0.47 | 0.46 | 0.46 |
| 7300 | 0.46 | 0.46 | 0.46 |
| 7350 | 0.46 | 0.46 | 0.46 |
| 7400 | 0.46 | 0.45 | 0.45 |
| 7450 | 0.45 | 0.45 | 0.45 |
| 7500 | 0.45 | 0.45 | 0.45 |
| 7550 | 0.45 | 0.45 | 0.44 |
| 7600 | 0.45 | 0.44 | 0.44 |
| 7650 | 0.44 | 0.44 | 0.44 |
| 7700 | 0.44 | 0.44 | 0.44 |
| 7750 | 0.44 | 0.43 | 0.43 |
| 7800 | 0.43 | 0.43 | 0.43 |
| 7850 | 0.43 | 0.43 | 0.43 |
| 7900 | 0.43 | 0.43 | 0.42 |
| 7950 | 0.42 | 0.42 | 0.42 |
| 8000 | 0.42 | 0.42 | 0.42 |
| 8050 | 0.42 | 0.42 | 0.41 |
| 9000 | 0.37 | 0.37 | 0.37 |
| 10000 | 0.35 | 0.35 | 0.35 |
| 11000 | 0.34 | 0.34 | 0.34 |
| 12000 | 0.33 | 0.33 | 0.33 |
| 13000 | 0.33 | 0.33 | 0.33 |
| 14000 | 0.32 | 0.32 | 0.33 |
| 15000 | 0.32 | 0.33 | 0.33 |
| 15500 | 0.32 | 0.33 | 0.33 |
| 16000 | 0.32 | 0.32 | 0.33 |
| 17000 | 0.33 | 0.32 | 0.33 |

Typical Performance Curves

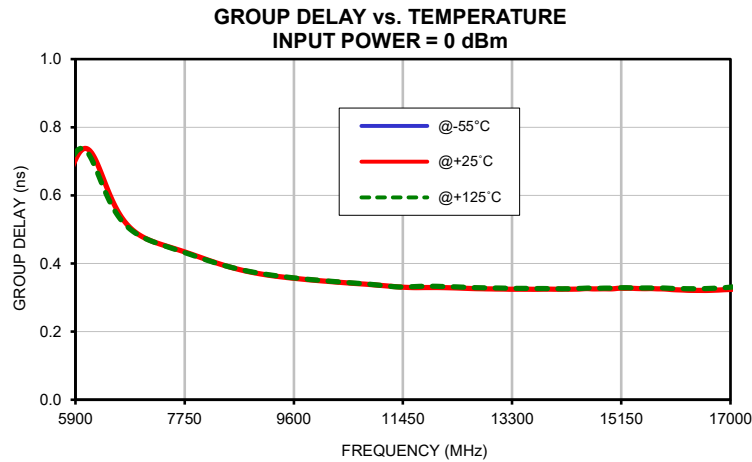
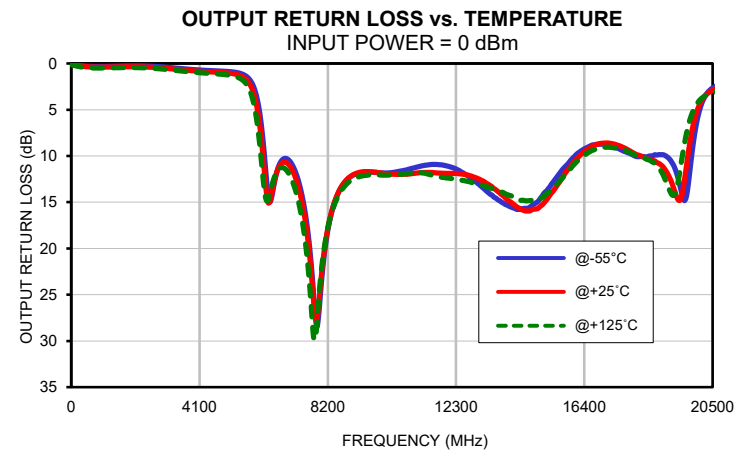
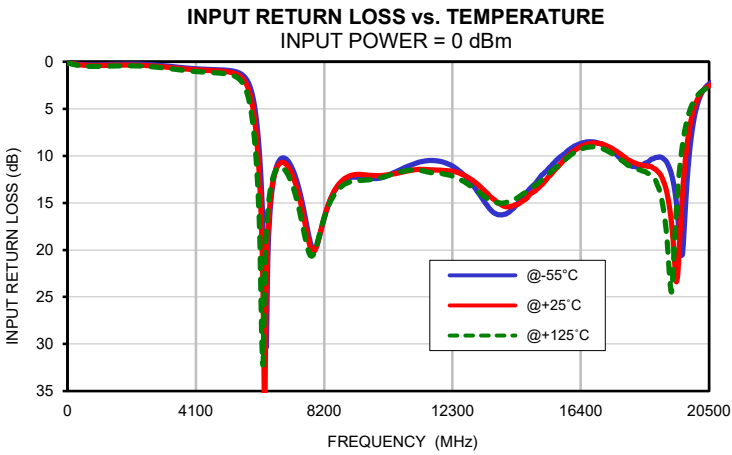
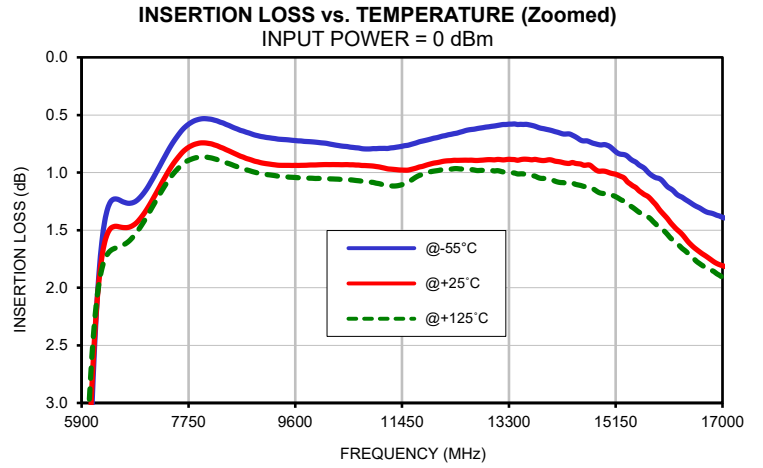
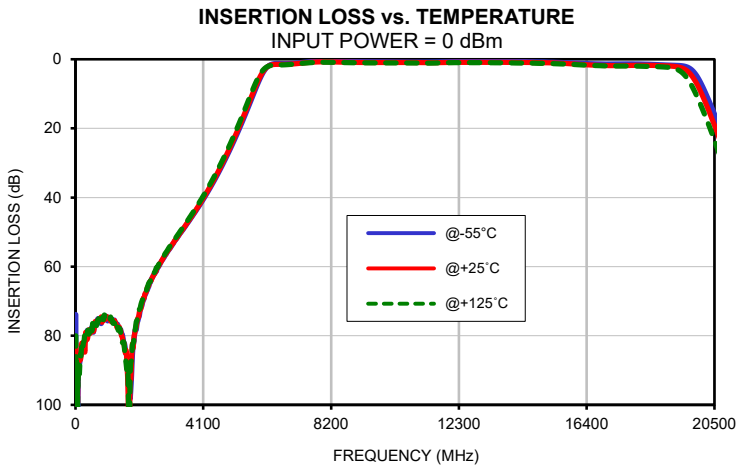

DEVICE ORIENTATION IN T&R

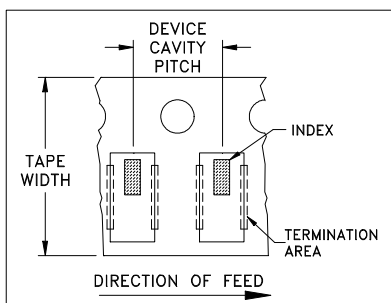

ILLUSTRATION 1

| Applicable Case Styles |
|------------------------|
| FV1206-1 |
| FV1206-3 |

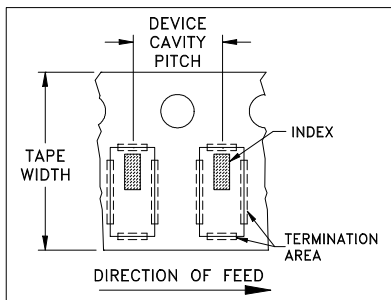

ILLUSTRATION 2

| Applicable Case Styles |
|------------------------|
| FV1206-4 |
| FV1206-5 |
| FV1206-6 |
| FV1206-7 |
| FV1206-9 |

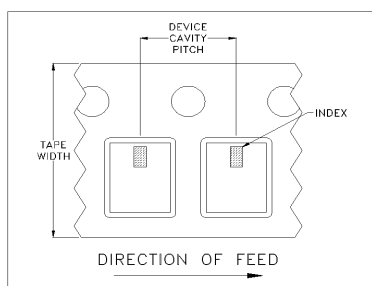

ILLUSTRATION 3

| Applicable Case Styles |
|------------------------|
| FV1206-11 |
| FV1206-12 |
| GE0805C-18 |
| NL1008C-6 |
| NL1008C-7 |
| NL1008C-9 |
| NL1008C-10 |
| NL1008C-12 |

| Tape Width, mm | Device Cavity Pitch, mm | Reel Size, inches | Devices per Reel | |
|----------------|-------------------------|-------------------|-------------------------------------|------|
| 8 | 4 | 7 | Small quantity standards (see note) | 20 |
| | | | | 50 |
| | | | | 100 |
| | | | | 200 |
| | | | | 500 |
| | | | | 1000 |
| | | | Standard | 3000 |

Note: Please consult individual model data sheet to determine device per reel availability.

Mini-Circuits carrier tape materials provide protection from ESD (Electro-Static Discharge) during handling and transportation. Tapes are static dissipative and comply with industry standards EIA-481/EIA-541.

Go to: www.minicircuits.com/pages/pdfs/tape.pdf



Distribution Centers NORTH AMERICA 800-654-7949 • 417-335-5935 • Fax 417-335-5945 • **EUROPE** 44-1252-832600 • Fax 44-1252-837010
 Mini-Circuits ISO 9001 & ISO 14001 Certified

INTERNET <http://www.minicircuits.com>

P.O. Box 350166, Brooklyn, New York 11235-0003 (718) 934-4500 Fax (718) 332-4661

THIRD ANGLE PROJECTION

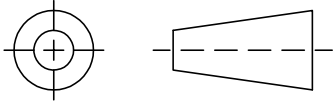

REVISIONS

| REV | ECN No. | DESCRIPTION | DATE | DR | AUTH |
|-----|------------|-----------------------------|--------|-----|------|
| OR | ECO-023057 | NEW RELEASE | SEP 24 | AGS | GT |
| OR1 | NPO-004738 | ADDED NL1008C-10 CASE STYLE | OCT 24 | AGS | GT |
| OR2 | ECO-023820 | NOTES & TOLERANCES UPDATED | NOV 24 | AGS | GT |

SUGGESTED MOUNTING CONFIGURATION FOR NL1008C-9, NL1008C-10 CASE STYLE

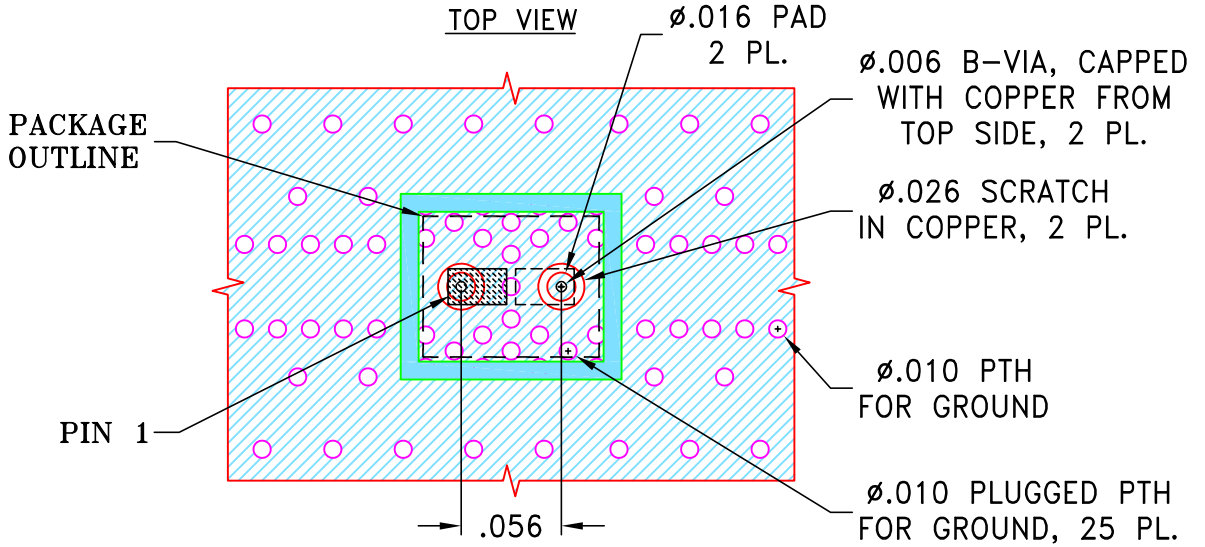

STACK-UP DIAGRAM

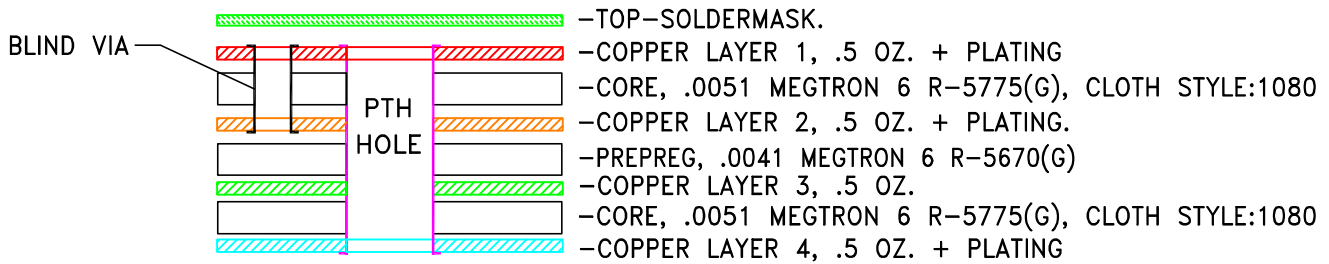

1. TOTAL FINISHED THICKNESS 0.0228±.004
2. B-VIA PRESENT FROM COPPER LAYER 1 TO COPPER LAYER 2.
3. PTH PRESENT FROM COPPER LAYER 1 TO COPPER LAYER 4.
4. INDICATED ON TOP VIEW PTH'S ARE PLUGGED WITH EPOXY AND CAPPED WITH COPPER FROM TOP SIDE.
5. L4 IS CONTINUOUS GROUND PLANE.

NOTES:

1. DIMENSIONS ARE IN INCHES ; \boxed{CD} DENOTES CRITICAL DIMENSIONS.
2. PCB IS MULTILAYER, SEE STACK-UP DIAGRAM AND SHEET-2 FOR ILLUSTRATION.
3. TRACE WIDTH & GAP PARAMETERS ARE SHOWN FOR MEGTRON 6 R-5775(G), CLOTH STYLE:1080 WITH DIELECTRIC THICKNESS .0051; COPPER: 1/2 OZ.+PLATING. FOR OTHER MATERIALS TRACE WIDTH AND GAP MAY NEED TO BE MODIFIED.
4. COPPER LAYER 4 OF THE PCB ARE CONTINUOUS GROUND PLANE.



DENOTES PCB COPPER LAYOUT WITH SMOBC (SOLDER MASK OVER BARE COPPER)

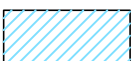

DENOTES COPPER LAND PATTERN FREE OF SOLDER MASK

| UNLESS OTHERWISE SPECIFIED | INITIALS | DATE |
|----------------------------|--------------|-----------|
| DIMENSIONS ARE IN INCHES | DRAWN AGS | 14 SEP 24 |
| TOLERANCES ON: | CHECKED MD | 16 SEP 24 |
| 2 PL DECIMALS ± | APPROVED GTP | 17 SEP 24 |
| 3 PL DECIMALS ± .002 | | |
| ANGLES ± | | |
| FRACTIONS ± | | |



Mini-Circuits®

13 Neptune Avenue
Brooklyn NY 11235

PL, NL1008C-9/10, TB-LFHK-XXXX+

Mini-Circuits®
THIS DOCUMENT AND ITS CONTENTS ARE THE PROPERTY OF MINI-CIRCUITS. EXCEPT FOR USE EXPRESSLY GRANTED, IN WRITING, TO ITS VENDORS, VENDEE AND THE UNITED STATES GOVERNMENT, MINI-CIRCUITS RESERVES ALL PROPRIETARY DESIGN, USE, MANUFACTURING AND REPRODUCTION RIGHTS THERETO. THESE CONTENTS SHALL NOT BE USED, DUPLICATED OR DISCLOSED TO ANY OUTSIDE PARTY, IN WHOLE OR IN PART, WITHOUT WRITTEN PERMISSION OF MINI-CIRCUITS.

| SIZE | CODE IDENT | DRAWING NO: | REV: |
|-------|------------|-------------|--------|
| A | 15542 | 98-PL-798 | OR2 |
| FILE: | 98-PL-798 | SCALE: | SHEET: |
| | | 9:1 | 1 OF 2 |

LAYER 1, SOLDER MASK & PTH

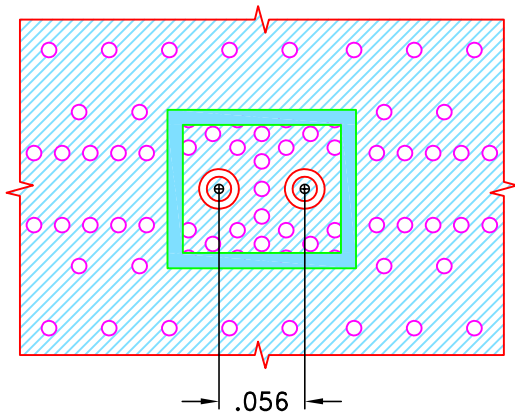

LAYER 2, B-VIA & PTH

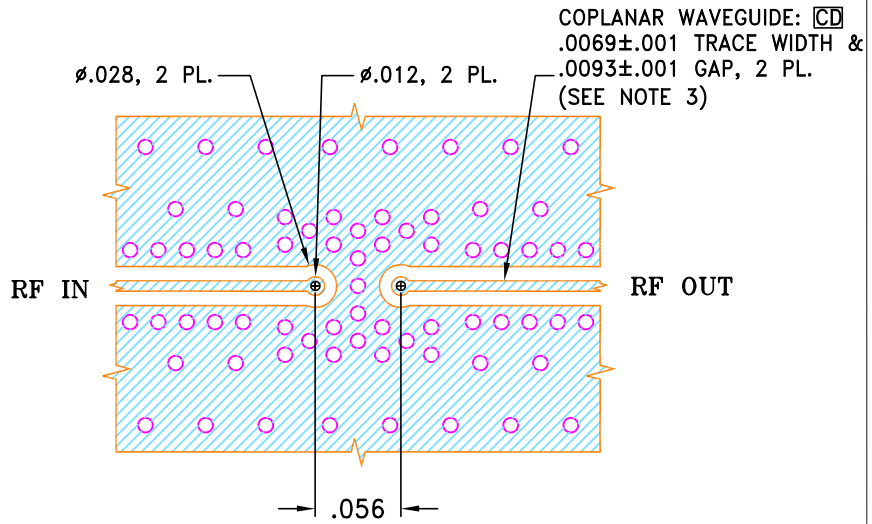

LAYER 3 & PTH

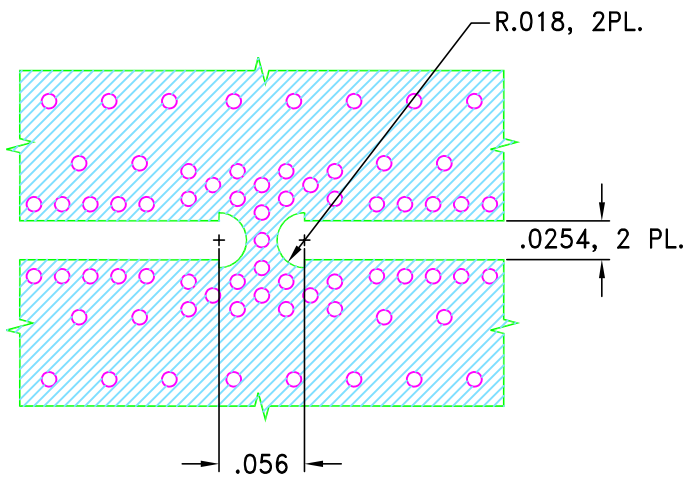

LAYER 4 & PTH

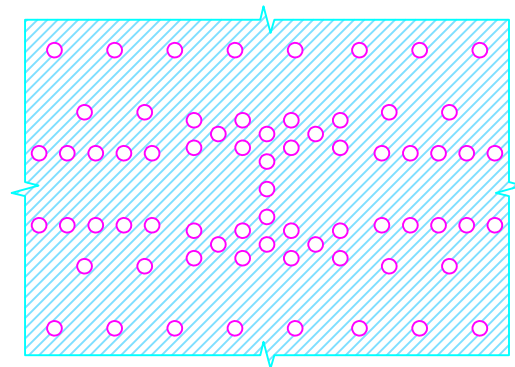

 Mini-Circuits

THIS DOCUMENT AND ITS CONTENTS ARE THE PROPERTY OF MINI-CIRCUITS. EXCEPT FOR USE EXPRESSLY GRANTED, IN WRITING, TO ITS VENDORS, VENDEE AND THE UNITED STATES GOVERNMENT, MINI-CIRCUITS RESERVES ALL PROPRIETARY DESIGN, USE, MANUFACTURING AND REPRODUCTION RIGHTS THERETO. THESE CONTENTS SHALL NOT BE USED, DUPLICATED OR DISCLOSED TO ANY OUTSIDE PARTY, IN WHOLE OR IN PART, WITHOUT WRITTEN PERMISSION OF MINI-CIRCUITS.

ALL DIMENSIONS ARE IN INCHES EXCEPT OTHERWISE SPECIFIED

| | | | |
|-----------|---------------------|--------------------------|-------------|
| SIZE A | CODE IDENT 15542 | DRAWING NO: 98-PL-798 | REV: OR2 |
|-----------|---------------------|--------------------------|-------------|

ASHEETA2.DWG REV:A DATE: 01/12/94

| | | |
|--------------------|-----------------|------------------|
| FILE: 98-PL-798 | SCALE: 7.7:1 | SHEET: 2 OF 2 |
|--------------------|-----------------|------------------|

Evaluation Board and Circuit

TB-HFHK-6010+

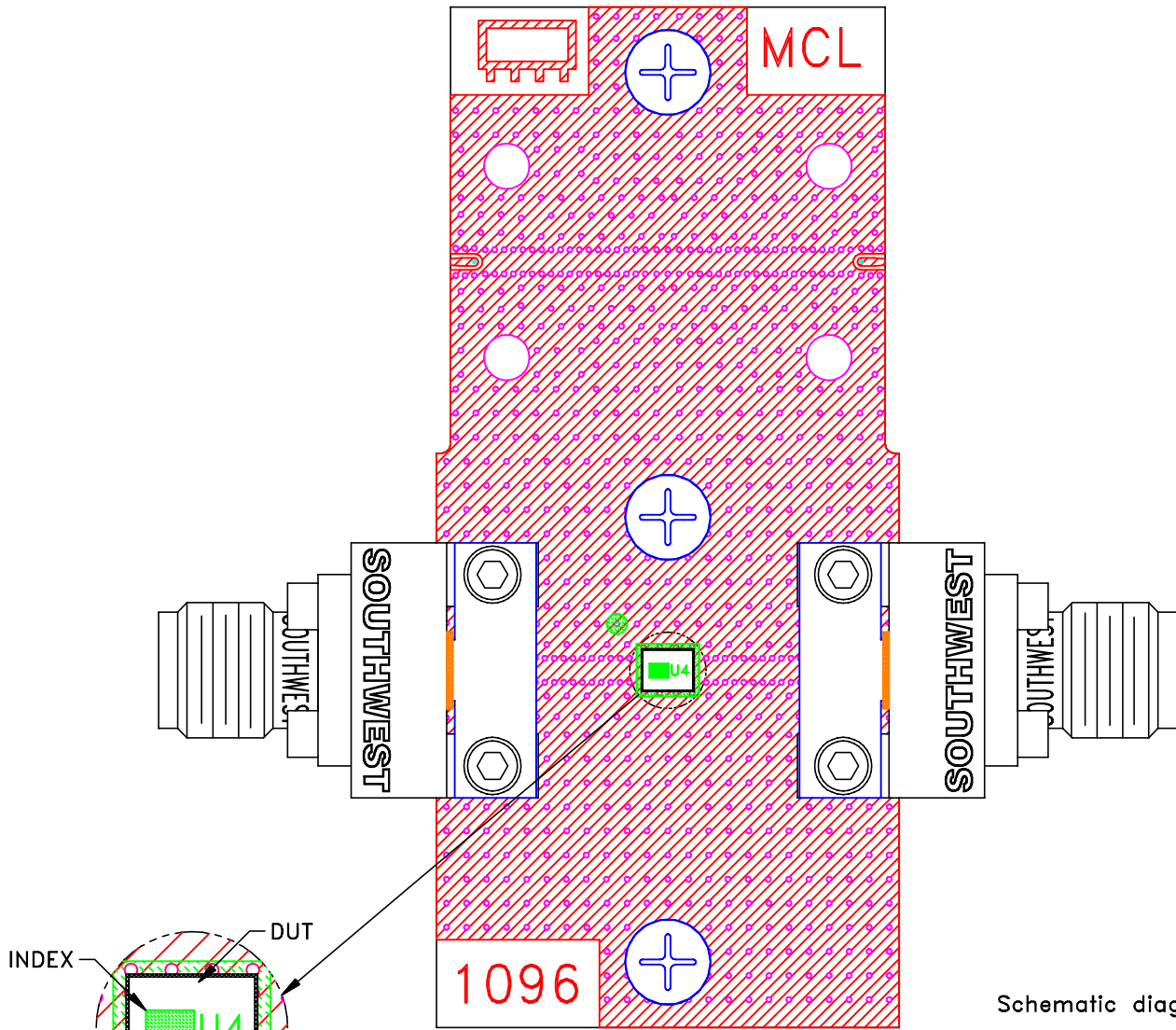

Schematic diagram

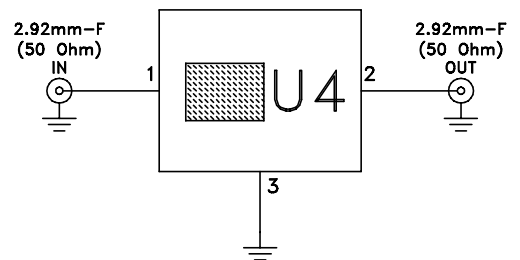

STACK-UP DIAGRAM

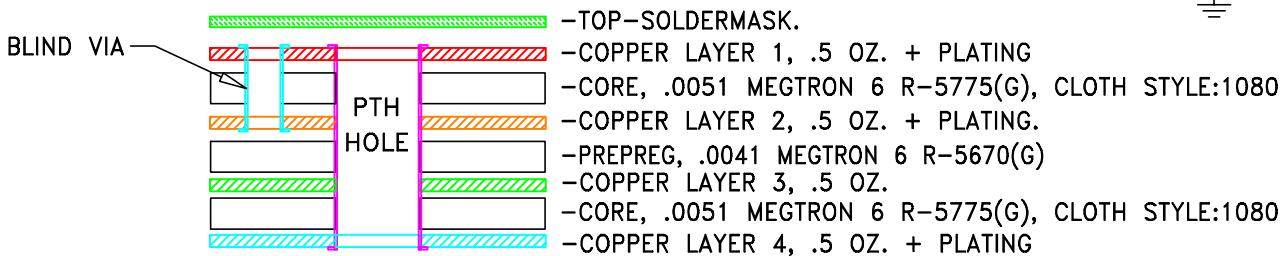

Notes:

1. PCB Material: MEGTRON-6 R5775(G) OR Equivalent, Dielectric Constant=3.6
2. Total finished thickness: .023 inch
3. 50 Ohm 2.92mm Female End Launch Connector.

 **Mini-Circuits®**



All Mini-Circuits products are manufactured under exacting quality assurance and control standards, and are capable of meeting published specifications after being subjected to any or all of the following physical and environmental test.

| Specification | Test/Inspection Condition | Reference/Spec |
|-----------------------|--|--|
| Operating Temperature | -55° to 125° C Ambient Environment | Individual Model Data Sheet |
| Storage Temperature | -55° to 125° C Ambient Environment | Individual Model Data Sheet |
| Humidity | 90 to 95% RH, 240 hours, 50°C | MIL-STD-202, Method 103, Condition A, Except 50°C and end-point electrical test done within 12 hours |
| Solder Reflow Heat | Sn-Pb Eutectic Process 225°C peak Pb-Free Process 245° - 250°C peak | J-STD-020C, Table 4-1, 4-2 and 5-2, Figure 5-1 |
| Solderability | 10X Magnification | J-STD-002, Test B,B1, 95% Coverage |
| Thermal Shock | -55° to +125°C, 15 min dwell,250 cycles | MIL-STD-202, Method 107 |
| Bend Test | 1mm, deflection for 5 seconds Span of bending: 2.75" | -- |
| High Temp Storage | 125°C to 1000 Hrs | --- |