



COAXIAL

# Adapter

## KFFL-KF50+

50Ω DC to 40 GHz 2.92 mm Female to 2.92 mm Female

### THE BIG DEAL

- Ultra-Wideband, DC to 40 GHz
- Flat Response
- Low Insertion Loss, 0.15 dB Typ.
- Excellent VSWR, 1.15:1
- Stainless Steel Construction



Generic photo used for illustration purposes only

### APPLICATIONS

- Interconnection of RF Cables and Equipment
- Instrumentation

Model No.	KFFL-KF50+
Case Style	DJ2261
Connectors	2.92 mm Female to 2.92 mm Female

**+RoHS Compliant**  
 The +Suffix identifies RoHS Compliance.  
 See our website for methodologies and qualifications

### PRODUCT OVERVIEW

Mini-Circuits' KFFL-KF50+ is a coaxial 2.92 mm female to 2.92 mm female four-hole flange-mount adapter supporting a wide range of applications from DC to 40 GHz. This model provides excellent VSWR, low insertion loss, and flat response versus frequency. The KFFL-KF50+ features a four-hole flange ideal for mounting connectors through panels in contained assemblies.

### KEY FEATURES

Features	Advantages
Wideband, DC to 40 GHz	Wide frequency range provides application flexibility and makes this model ideal for broadband and multi-band use.
Excellent VSWR, 1.15:1	Provides good matching for 50Ω systems and minimizes signal reflections across wide frequency range.
Low Insertion Loss, 0.15 dB Typ.	Provides excellent signal power transmission from input to output.
Four-Hole Flange	Ideal for mounting connectors through panels in contained assemblies.
Very Wide Operating Temperature Range, -45 °C to +100 °C	Withstands extreme operating conditions and is suitable for use near high power componentry where heat rise is common.

REV. B  
 ECO-024981  
 KFFL-KF50+  
 MCL NY  
 260506





COAXIAL

# Adapter

## KFFL-KF50+

50Ω DC to 40 GHz 2.92 mm Female to 2.92 mm Female

### ELECTRICAL SPECIFICATIONS AT +25 °C

Parameter	Condition (GHz)	Min.	Typ.	Max.	Units
Frequency Range	-	DC	-	40	GHz
Insertion Loss	DC-40	-	0.15	0.6	dB
VSWR	DC-40	-	-	1.15	:1

### ABSOLUTE MAXIMUM RATINGS<sup>1</sup>

Parameter	Ratings
Operating Temperature	-45 °C to +100 °C
Storage Temperature	-55 °C to +100 °C

1. Permanent damage may occur if any of these limits are exceeded.



COAXIAL

# Adapter

## KFFL-KF50+

50Ω DC to 40 GHz 2.92 mm Female to 2.92 mm Female

### COAXIAL CONNECTIONS

Connector 1	2.92 mm female
Connector 2	2.92 mm female

### OUTLINE DRAWING

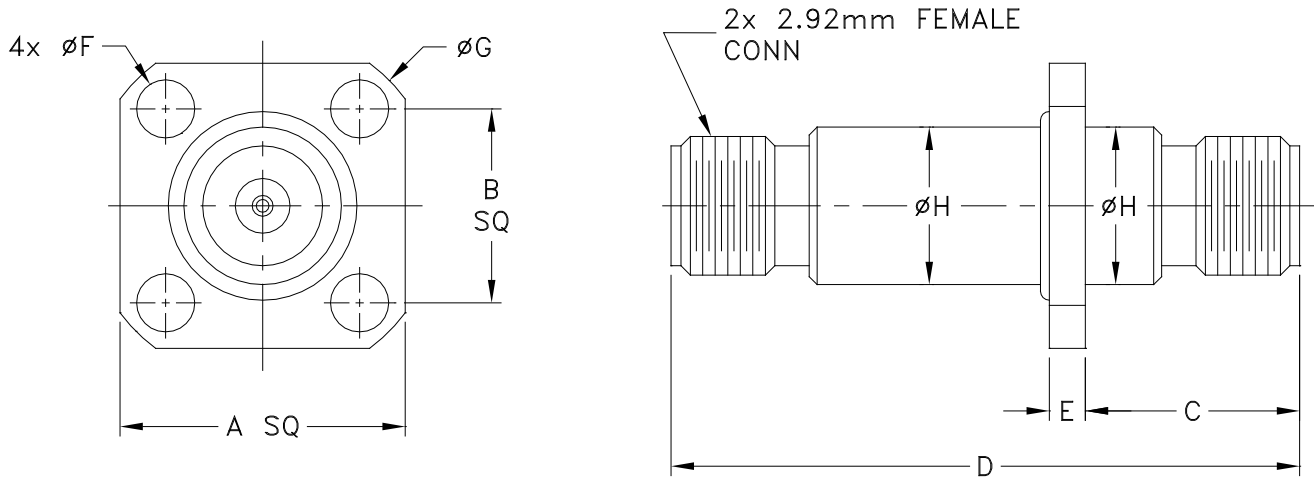

### OUTLINE DIMENSIONS (Inches/mm)

A	B	C	D	E	F	G	H	wt.
.50	.339	.38	1.10	.06	.102	.622	.276	grams
12.7	8.6	9.6	28.0	1.6	2.6	15.8	7.0	5.6



COAXIAL

# Adapter

## KFFL-KF50+

50Ω DC to 40 GHz 2.92 mm Female to 2.92 mm Female

### TYPICAL PERFORMANCE DATA AND CHARTS

Frequency (MHz)	Insertion Loss (dB)	VSWR (:1)	
		2.92 mm Female	2.92 mm Female
10	0.04	1.00	1.00
100	0.02	1.01	1.01
1000	0.06	1.02	1.02
2000	0.07	1.02	1.02
3000	0.07	1.02	1.01
4000	0.08	1.01	1.00
5000	0.08	1.01	1.02
6000	0.08	1.03	1.03
7000	0.09	1.04	1.04
8000	0.09	1.04	1.04
9000	0.09	1.02	1.02
10000	0.09	1.00	1.01
12000	0.10	1.06	1.06
14000	0.11	1.07	1.08
16000	0.11	1.02	1.02
18000	0.13	1.05	1.06
20000	0.14	1.09	1.09
24000	0.14	1.03	1.03
28000	0.14	1.02	1.03
32000	0.16	1.04	1.03
36000	0.19	1.14	1.13
40000	0.17	1.06	1.04

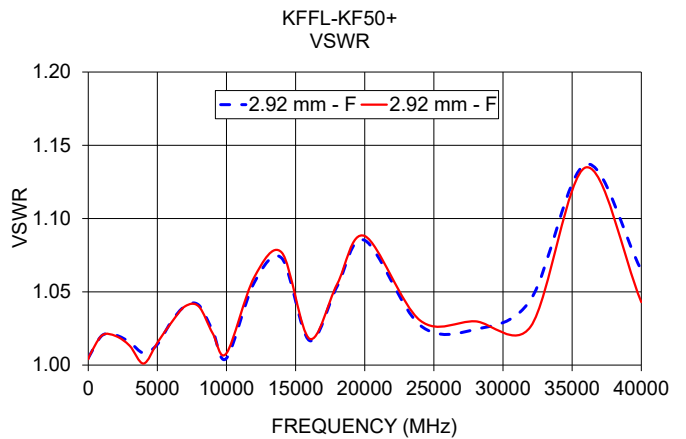
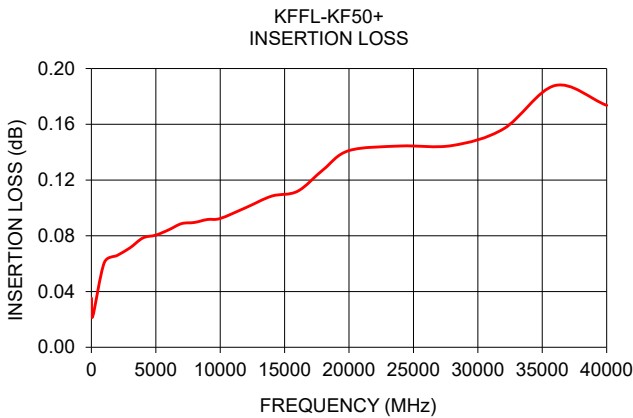

#### NOTES

- A. Performance and quality attributes and conditions not expressly stated in this specification document are intended to be excluded and do not form a part of this specification document.
- B. Electrical specifications and performance data contained in this specification document are based on Mini-Circuit's applicable established test performance criteria and measurement instructions.
- C. The parts covered by this specification document are subject to Mini-Circuits standard limited warranty and terms and conditions (collectively, "Standard Terms"); Purchasers of this part are entitled to the rights and benefits contained therein. For a full statement of the standard terms and the exclusive rights and remedies thereunder, please visit Mini-Circuits' website at [www.minicircuits.com/terms/viewterm.html](http://www.minicircuits.com/terms/viewterm.html)



*Typical Performance Data*

FREQUENCY (MHz)	INSERTION LOSS (dB)	K-FEMALE 1 VSWR (:1)	K-FEMALE 2 VSWR (:1)
10	0.04	1.00	1.00
20	0.01	1.01	1.01
30	0.01	1.00	1.01
40	0.01	1.00	1.01
50	0.01	1.00	1.01
60	0.02	1.00	1.01
70	0.02	1.00	1.00
80	0.02	1.00	1.01
90	0.02	1.01	1.01
100	0.02	1.01	1.01
110	0.02	1.01	1.01
120	0.02	1.01	1.01
130	0.02	1.01	1.01
140	0.02	1.01	1.01
150	0.03	1.01	1.01
160	0.03	1.01	1.01
170	0.03	1.01	1.01
180	0.03	1.01	1.01
190	0.03	1.01	1.01
200	0.03	1.01	1.01
300	0.04	1.01	1.01
400	0.05	1.01	1.01
500	0.05	1.02	1.01
600	0.05	1.02	1.01
700	0.06	1.02	1.02
800	0.06	1.02	1.02
900	0.06	1.02	1.02
1000	0.06	1.02	1.02
1500	0.06	1.02	1.02
2000	0.07	1.02	1.02
3000	0.07	1.02	1.01
4000	0.08	1.01	1.00
5000	0.08	1.01	1.02
6000	0.08	1.03	1.03
7000	0.09	1.04	1.04
8000	0.09	1.04	1.04
9000	0.09	1.02	1.02
10000	0.09	1.00	1.01
11000	0.09	1.03	1.03
12000	0.10	1.06	1.06
13000	0.11	1.07	1.08
14000	0.11	1.07	1.08
15000	0.11	1.05	1.05
16000	0.11	1.02	1.02
17000	0.12	1.02	1.03
18000	0.13	1.05	1.06
19000	0.13	1.08	1.08
20000	0.14	1.09	1.09
21000	0.14	1.06	1.07
22000	0.14	1.03	1.04
23000	0.14	1.01	1.02
24000	0.14	1.03	1.03
25000	0.15	1.04	1.04
26000	0.15	1.05	1.05
27000	0.15	1.03	1.05
28000	0.14	1.02	1.03
29000	0.15	1.04	1.03
30000	0.15	1.06	1.04
31000	0.15	1.06	1.04
32000	0.16	1.04	1.03
33000	0.16	1.03	1.01
34000	0.17	1.06	1.07
35000	0.18	1.10	1.10
36000	0.19	1.14	1.13
37000	0.19	1.14	1.14
38000	0.17	1.11	1.11
39000	0.17	1.07	1.06
40000	0.17	1.06	1.04



P.O. Box 350166, Brooklyn, New York 11235-0003 • Fax (718) 934-4500 • Fax (718) 332-4661 For detailed performance specs & shopping online see Mini-Circuits web site

The Design Engineers Search Engine Provides ACTUAL Data Instantly From MINI-CIRCUITS At: [www.minicircuits.com](http://www.minicircuits.com)

**IF/RF MICROWAVE COMPONENTS**

## Typical Performance Curves

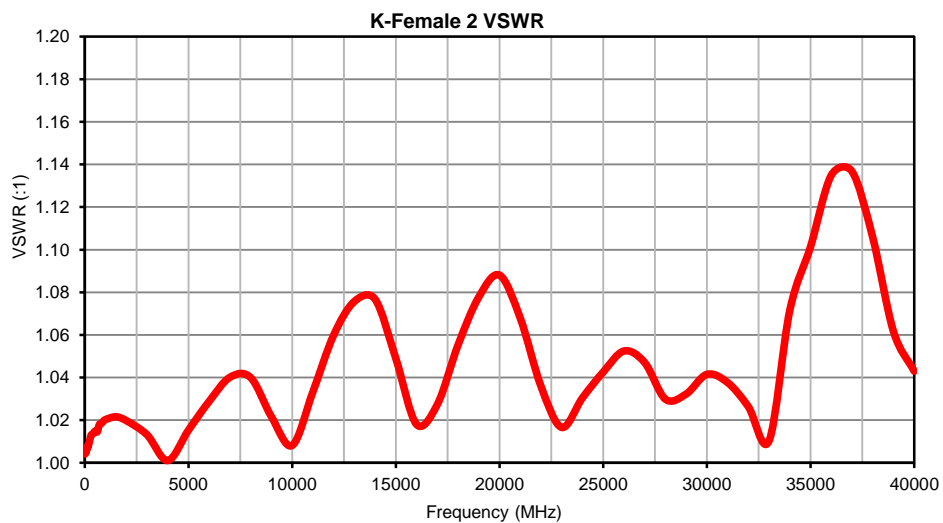
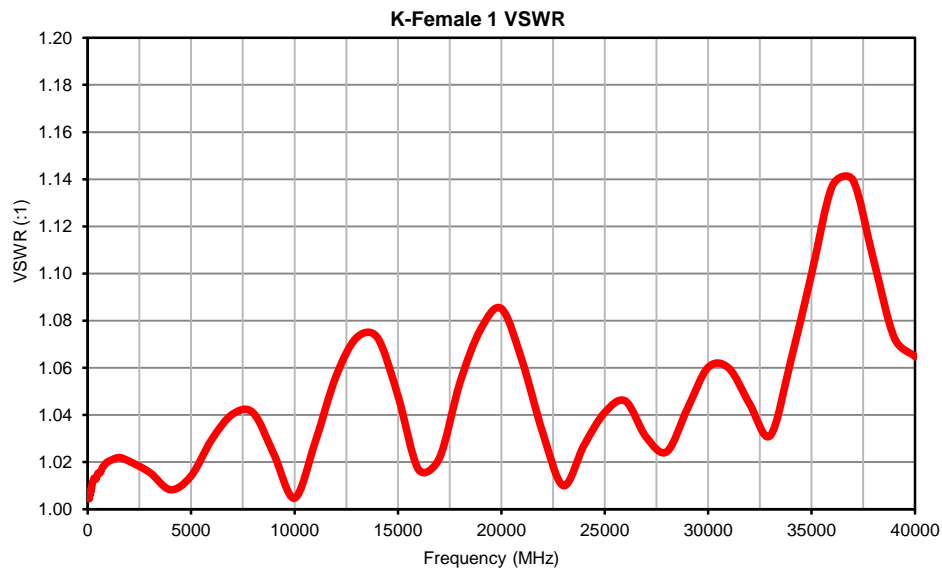

### Outline Dimensions

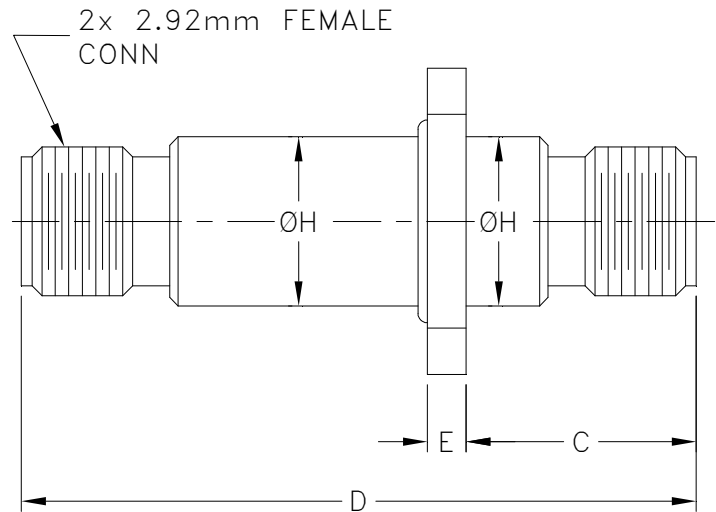
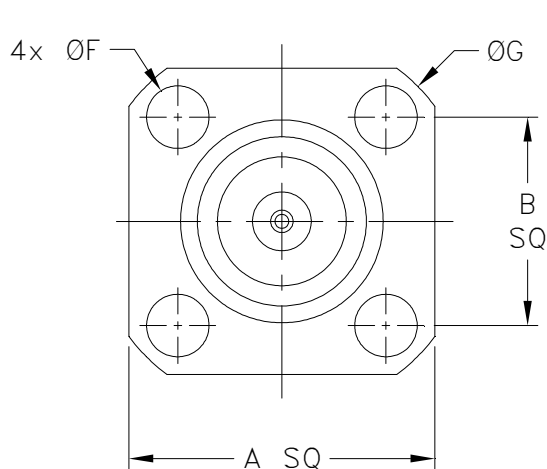

CASE #	A	B	C	D	E	F	G	H	WT. GRAM
DJ2261	.50 (12.7)	.339 (8.6)	.38 (9.6)	1.10 (28.0)	.06 (1.6)	.102 (2.6)	.622 (15.8)	.276 (7.0)	5.6

Dimensions are in inches (mm). Tolerances: 2 Pl.  $\pm .002$ ; 3Pl.  $+ .001$

#### Notes:

1. Case material: Stainless Steel.
2. Finish: Passivation.

All Mini-Circuits products are manufactured under exacting quality assurance and control standards, and are capable of meeting published specifications after being subjected to any or all of the following physical and environmental test.

<b>Specification</b>	<b>Test/Inspection Condition</b>	<b>Reference/Spec</b>
Operating Temperature	-55° to 100° C or -55° to 85° C Ambient Environment	Individual Model Data Sheet
Storage Temperature	-55° to 100° C Ambient Environment	Individual Model Data Sheet
Thermal Shock	-55° to 100°C, 100 cycles	MIL-STD-202, Method 107, condition B -3, except over -55° to 100°C
Connector Durability	500 mating/unmating cycles	MIL-PRF-39012E, PARAGRAPH 4.6.12
Drop Test	3' height, 3 times	