

Coaxial

Adapter 2.92mm NMD-M to 2.92mm-NMD-F **KFNMD-KMNMD+**

50Ω DC to 40 GHz

The Big Deal

- Ultra-wideband, DC-40 GHz
- Flat response
- Low insertion loss, 0.06 dB typ.
- Excellent VSWR, 1.05:1 typ.



CASE STYLE: DJ2931-4

Product Overview

Mini-Circuits' KFNMD-KMNMD+ is a coaxial 2.92mm NMD-M to 2.92mm-F adapter supporting a wide range of applications from DC to 40 GHz. This model provides excellent VSWR, low insertion loss, and flat response versus frequency. The KFNMD-KMNMD+ features passivated stainless steel construction and measures only 0.827" (l).

Key Features

Feature	Advantages
Wideband, DC to 40 GHz	Wide frequency range provides application flexibility and makes this model ideal for broad-band and multi-band use.
Excellent VSWR, 1.05:1 typ.	Provides good matching for 50Ω systems and minimizes signal reflections across wide frequency range.
Low insertion loss, 0.06 dB typ.	Provides excellent signal power transmission from input to output.
Passivated stainless steel construction.	Stands up to wear and tear in demanding environments and provides excellent reliability.
Very wide operating temperature range, -55 to +100°C	Withstands extreme operating conditions and is suitable for use near high power components where heat rise is common.

Notes

- A. Performance and quality attributes and conditions not expressly stated in this specification document are intended to be excluded and do not form a part of this specification document.
B. Electrical specifications and performance data contained in this specification document are based on Mini-Circuit's applicable established test performance criteria and measurement instructions.
C. The parts covered by this specification document are subject to Mini-Circuits standard limited warranty and terms and conditions (collectively, "Standard Terms"); Purchasers of this part are entitled to the rights and benefits contained therein. For a full statement of the Standard Terms and the exclusive rights and remedies thereunder, please visit Mini-Circuits' website at www.minicircuits.com/MCLStore/terms.jsp



Coaxial Adapter

2.92mm NMD-M to 2.92mm-NMD-F

KFNMD-KMNMD+

50Ω DC to 40 GHz

Maximum Ratings

Operating Temperature	-55°C to 100°C
Storage Temperature	-55°C to 100°C

Permanent damage may occur if any of these limits are exceeded.

Features

- flat response
- excellent VSWR, 1.05:1 typ. up to 40 GHz
- low cost adapters, available from stock
- stainless steel body, passivated

Applications

- interconnection of RF cable and equipment



Generic photo used for illustration purposes only
CASE STYLE: DJ2931-4

Connectors	Model
2.92mm NMD-M to 2.92mm-NMD-F	KFNMD-KMNMD+

+RoHS Compliant

The +Suffix identifies RoHS Compliance. See our web site for RoHS Compliance methodologies and qualifications

Outline Drawing

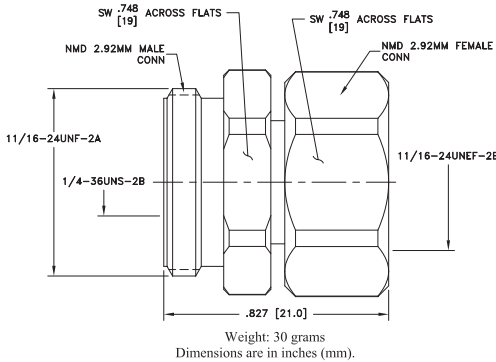

Electrical Specifications at 25°C

Parameter	Condition (GHz)	Min.	Typ.	Max.	Units
Frequency Range		DC		40	GHz
Insertion Loss	DC - 40	—	0.06	—	dB
VSWR	DC - 40	—	1.05	1.2	:1

Typical Performance Data

Frequency (MHz)	Insertion Loss (dB)	VSWR (:1)	
		2.92mm NMD-M	2.92mm-NMD-F
10	0.00	1.00	1.00
100	0.00	1.00	1.00
1000	0.02	1.01	1.01
4000	0.03	1.01	1.01
8000	0.04	1.02	1.01
10000	0.04	1.03	1.02
12000	0.04	1.04	1.03
14000	0.04	1.05	1.03
18000	0.05	1.05	1.02
20000	0.04	1.04	1.01
24000	0.05	1.03	1.05
28000	0.06	1.11	1.12
30000	0.07	1.14	1.13
32000	0.07	1.14	1.10
34000	0.07	1.11	1.05
36000	0.07	1.07	1.03
38000	0.06	1.04	1.05
40000	0.05	1.06	1.07

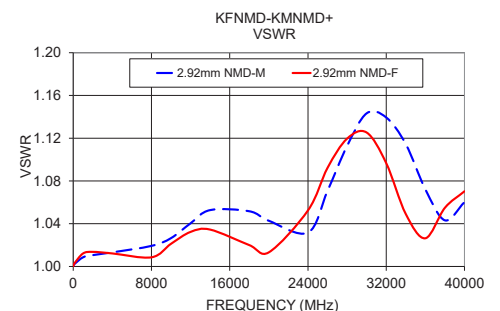
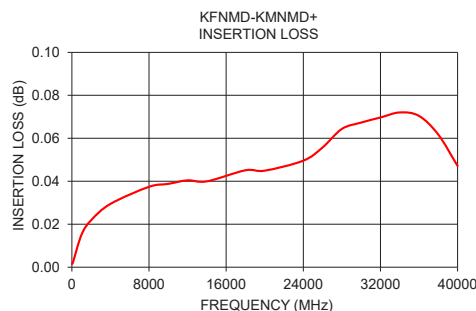

Notes

- Performance and quality attributes and conditions not expressly stated in this specification document are intended to be excluded and do not form a part of this specification document.
- Electrical specifications and performance data contained in this specification document are based on Mini-Circuit's applicable established test performance criteria and measurement instructions.
- The parts covered by this specification document are subject to Mini-Circuit's standard limited warranty and terms and conditions (collectively, "Standard Terms"); Purchasers of this part are entitled to the rights and benefits contained therein. For a full statement of the Standard Terms and the exclusive rights and remedies thereunder, please visit Mini-Circuit's website at www.minicircuits.com/MCLStore/terms.jsp



www.minicircuits.com P.O. Box 350166, Brooklyn, NY 11235-0003 (718) 934-4500 sales@minicircuits.com

REV. OR
M176256
KFNMD-KMNMD+
BK/RS/CP
190904

Typical Performance Data

FREQUENCY (MHz)	INSERTION LOSS (dB)	2.92mm NMD-FEMALE VSWR (:1)	2.92mm NMD-MALE VSWR (:1)
10	0.00	1.00	1.00
100	0.00	1.00	1.00
1000	0.02	1.01	1.01
2000	0.02	1.01	1.01
4000	0.03	1.01	1.01
6000	0.04	1.01	1.02
8000	0.04	1.01	1.02
10000	0.04	1.02	1.03
12000	0.04	1.03	1.04
14000	0.04	1.03	1.05
16000	0.04	1.03	1.06
18000	0.05	1.02	1.05
20000	0.04	1.01	1.04
22000	0.05	1.02	1.02
24000	0.05	1.05	1.03
26000	0.06	1.09	1.07
28000	0.06	1.12	1.11
30000	0.07	1.13	1.14
32000	0.07	1.10	1.14
34000	0.07	1.05	1.11
36000	0.07	1.03	1.07
38000	0.06	1.05	1.04
40000	0.05	1.07	1.06

Typical Performance Curves

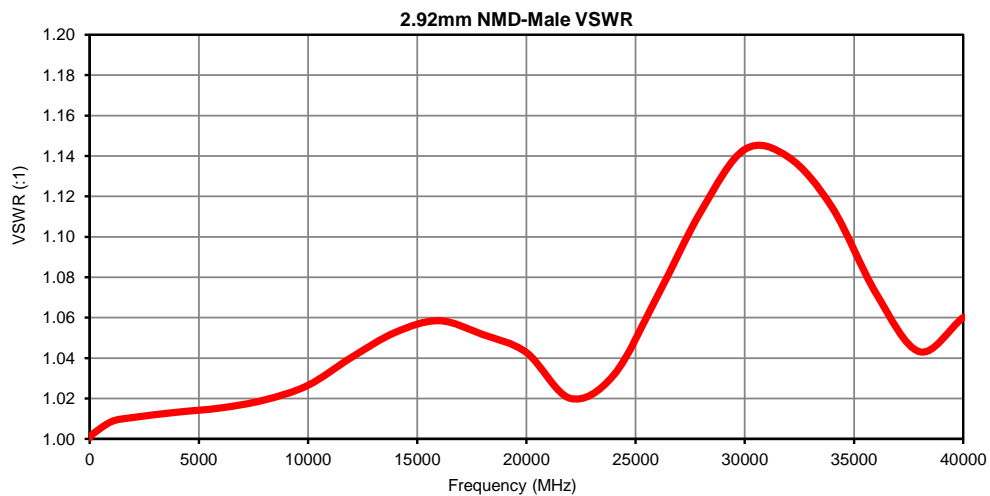
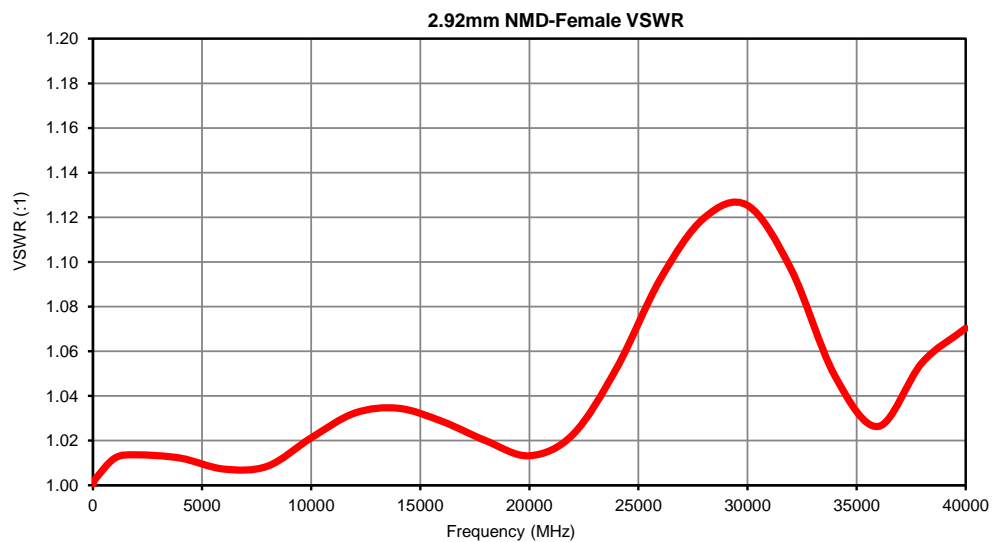

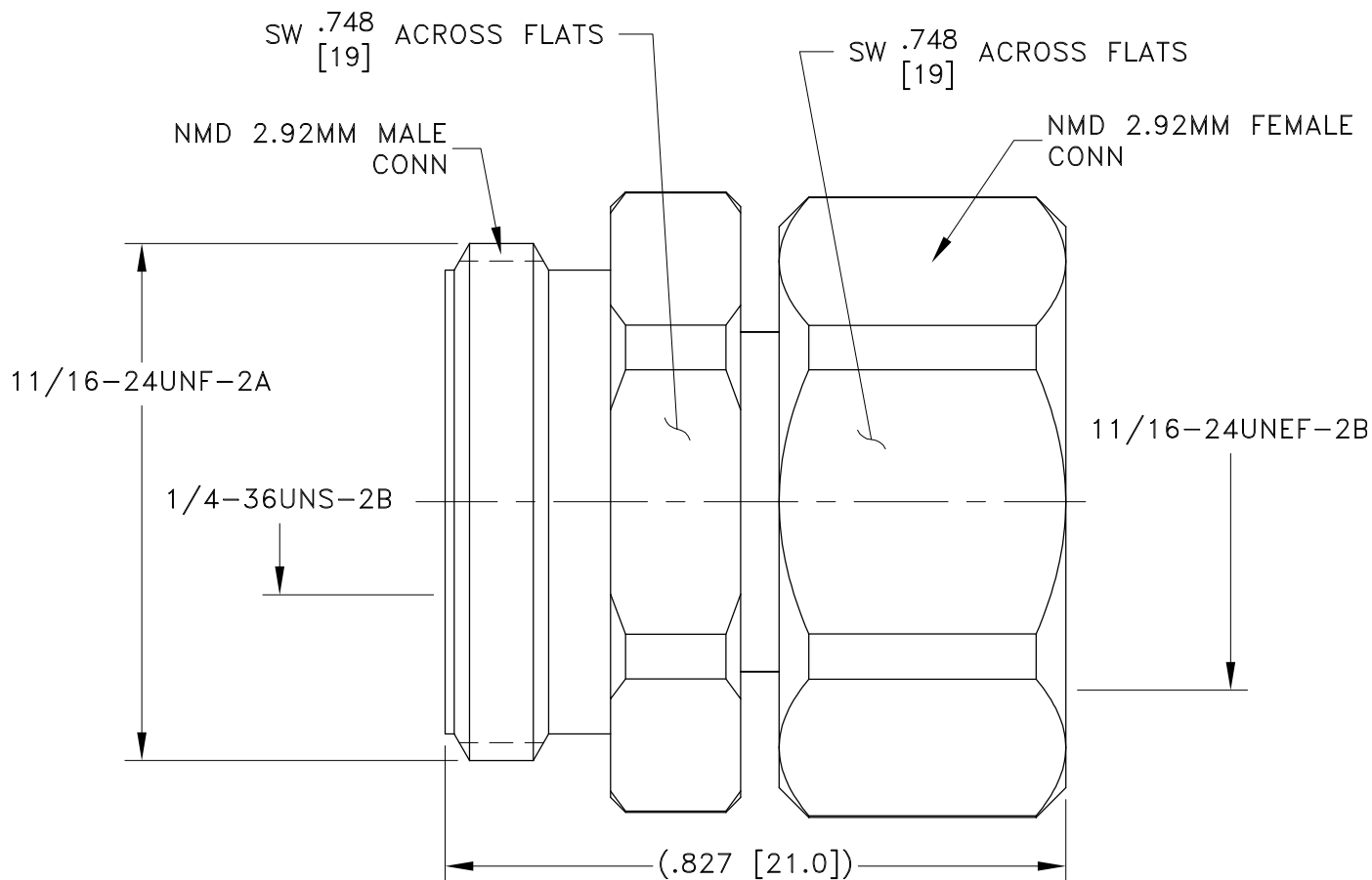

Weight: 30 grams

Dimensions are in inches (mm). Tolerances: 2 Pl. ± .03; 3 Pl. ± .015

Notes:

1. Case material: Stainless steel.
2. Finish: Passivation.



P.O. Box 350166, Brooklyn, New York 11235-0003 (718) 934-4500 Fax (718) 332-4661 For detailed performance specs & shopping online see Mini-Circuits web site



The Design Engineers Search Engine Provides ACTUAL Data Instantly From MINI-CIRCUITS At: www.minicircuits.com

RF/IF MICROWAVE COMPONENTS

All Mini-Circuits products are manufactured under exacting quality assurance and control standards, and are capable of meeting published specifications after being subjected to any or all of the following physical and environmental test.

Specification	Test/Inspection Condition	Reference/Spec
Operating Temperature	-55° to 100° C or -55° to 85° C Ambient Environment	Individual Model Data Sheet
Storage Temperature	-55° to 100° C Ambient Environment	Individual Model Data Sheet
Thermal Shock	-55° to 100°C, 100 cycles	MIL-STD-202, Method 107, condition B -3, except over -55° to 100°C
Connector Durability	500 mating/unmating cycles	MIL-PRF-39012E, PARAGRAPH 4.6.12
Drop Test	3' height, 3 times	