

# Surface Mount Switch

# KSWA-2-46+

## 50Ω SPDT, Absorptive DC<sup>4</sup> to 4.6 GHz

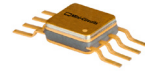

Generic photo used for illustration purposes only

CASE STYLE: XX112

**+RoHS Compliant**

The +Suffix identifies RoHS Compliance. See our web site for RoHS Compliance methodologies and qualifications

### Maximum Ratings

Operating Temperature	-55°C to 100°C
Storage Temperature	-55°C to 150°C
Input Power	see Note 1
Control V	see Note 2

Permanent damage may occur if any of these limits are exceeded.

### Pin Connections

RF IN	2
RF OUT 1	5
RF OUT 2	8
CONTROL 1	3
CONTROL 2	1
GROUND	4,6,7

### Outline Drawing

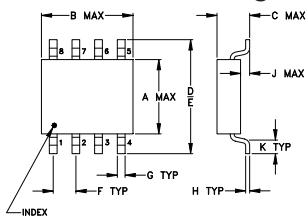

### PCB Land Pattern

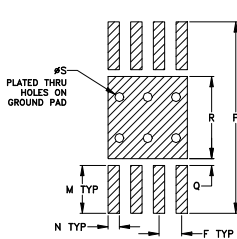

Suggested Layout, Tolerance to be within ±.002

### Outline Dimensions (inch/mm)

A	B	C	D	E	F	G	H	
.180	.180	.070	.400	.350	.050	.015	.005	
4.57	4.57	1.78	10.16	8.89	1.27	0.38	0.13	
J	K	M	N	P	Q	R	S	wt.
.005	.070	.105	.025	.420	.015	.180	.020	grams
0.13	1.78	2.67	0.64	10.67	0.38	4.57	0.51	0.15

### Demo Board MCL P/N: TB-204 Suggested PCB Layout (PL-217)

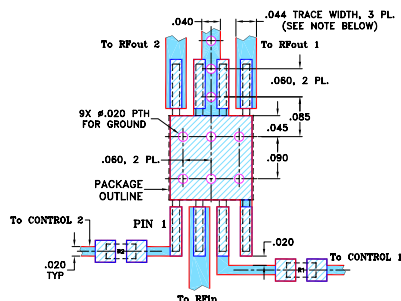

RESISTORS R1, R2: 100 Ohm, 0603 SIZE.  
 NOTE: 1. TRACE WIDTH IS SHOWN FOR ROGERS RO4350B WITH DIELECTRIC THICKNESS .020" ± .0015"; COPPER: 1/2 OZ. EACH SIDE. FOR OTHER MATERIALS TRACE WIDTH MAY NEED TO BE MODIFIED.  
 2. BOTTOM SIDE OF THE PCB IS CONTINUOUS GROUND PLANE.  
 DENOTES PCB COPPER LAYOUT WITH SMOBC (SOLDER MASK OVER BARE COPPER)  
 DENOTES COPPER LAND PATTERN FREE OF SOLDER MASK

### Features

- wideband, DC to 4.6 GHz
- low insertion loss, 1.3 dB typ.
- hermetically sealed
- aqueous washable

### Applications

- PCN
- cellular
- 2-way radio
- receiver antenna switching

### Electrical Specifications

FREQ. <sup>4</sup> (GHz)	INSERTION LOSS (dB)				1dB COMPR. (dBm)			IN-OUT ISOLATION (dB)									
	DC-200 MHz	200-1000 MHz	1000-3000 MHz	3000-4600 MHz	DC-200 MHz	200-1000 MHz	1000-4600 MHz	DC-200 MHz	200-1000 MHz	1000-4600 MHz							
f <sub>L</sub>	Typ.	Max.	Typ.	Max.	Typ.	Typ.	Typ.	Typ.	Min.	Typ.	Min.	Typ.	Min.				
DC	0.8	1.1	0.9	1.3	1.5	2.6	1.5	2.6	10	17	27	60	45	50	40	30	25

### Additional Specifications

Control Voltage, volts	
Low State	-0.2 to 0
High State (negative) for compression specs	-8
for other specs	-5 to -8
Control Current, mA	2.5 typ. at -8V
VSWR(:1)	1.3 typ.
Rise/Fall time (10%-90%), ns	2 typ.
Switching time, 50% of Control to 90% RF (Turn-on), ns	4 typ.
10% RF (Turn-off), ns	2.5 typ.
Video Leakage, mVp-p 0/-5V Control	30 typ.
MTBF, hrs @ 100°C case	11X10 <sup>6</sup>

### CONTROL LOGIC

Control Ports		RF outputs	
1	2	1	2
-V	0	On	Off
0	-V	Off	On

1. Max. Input RF power, +27 dBm except below 500 MHz +24 dBm
2. Control voltage (-10V) maximum.
3. Video leakage or break through is defined as leakage of switching signal to RF output ports.
4. All RF connections must be DC blocked or held at 0V DC.

### Electrical Schematic

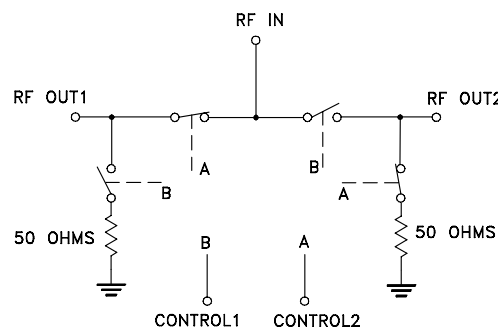

### Notes

- Performance and quality attributes and conditions not expressly stated in this specification document are intended to be excluded and do not form a part of this specification document.
- Electrical specifications and performance data contained in this specification document are based on Mini-Circuit's applicable established test performance criteria and measurement instructions.
- The parts covered by this specification document are subject to Mini-Circuits standard limited warranty and terms and conditions (collectively, "Standard Terms"); Purchasers of this part are entitled to the rights and benefits contained therein. For a full statement of the Standard Terms and the exclusive rights and remedies thereunder, please visit Mini-Circuits' website at [www.minicircuits.com/MCLStore/terms.jsp](http://www.minicircuits.com/MCLStore/terms.jsp)



## Typical Performance Data

FREQ. (MHz)	ON INSERTION LOSS (dB) Control @ 0V/-5V IN-OUT		OFF ISOLATION (dB) Control @ 0V/-5V IN-OUT		IN	VSWR		
	—	σ	—	σ		ON	OUT	OFF
	x		x			x		x
3.00	0.55	0.01	82.53	2.67	1.12	1.12	1.02	
5.00	0.55	0.02	85.42	4.39	1.12	1.12	1.02	
10.00	0.55	0.02	84.71	7.84	1.13	1.13	1.02	
20.00	0.63	0.04	74.57	2.52	1.13	1.12	1.02	
50.00	0.62	0.02	64.87	0.76	1.12	1.12	1.02	
100.00	0.67	0.02	58.56	0.45	1.12	1.12	1.02	
200.00	0.72	0.02	54.29	0.36	1.12	1.11	1.02	
500.00	0.80	0.02	51.52	0.42	1.13	1.12	1.02	
911.55	0.90	0.02	48.87	1.18	1.16	1.11	1.04	
1000.00	0.90	0.03	48.56	1.23	1.17	1.10	1.05	
1581.00	1.01	0.04	44.26	1.63	1.20	1.04	1.11	
2107.00	1.10	0.03	39.70	1.28	1.30	1.09	1.14	
2370.00	1.15	0.05	37.89	1.12	1.31	1.11	1.15	
2489.55	1.26	0.06	37.25	0.97	1.32	1.14	1.17	
2752.55	1.32	0.07	35.59	0.62	1.41	1.22	1.23	
3278.55	1.26	0.04	31.74	1.06	1.44	1.35	1.29	
3804.55	1.63	0.09	28.75	0.72	1.39	1.41	1.38	
4330.55	1.52	0.06	25.75	0.41	1.49	1.78	1.65	
4474.00	1.47	0.09	25.51	0.36	1.57	1.94	1.73	
4600.00	1.98	0.06	25.42	0.32	1.55	1.87	1.67	

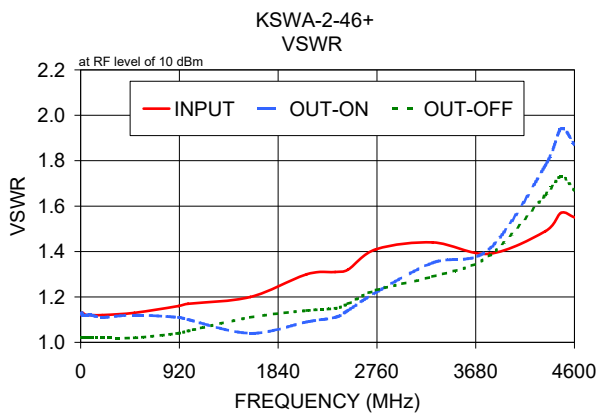
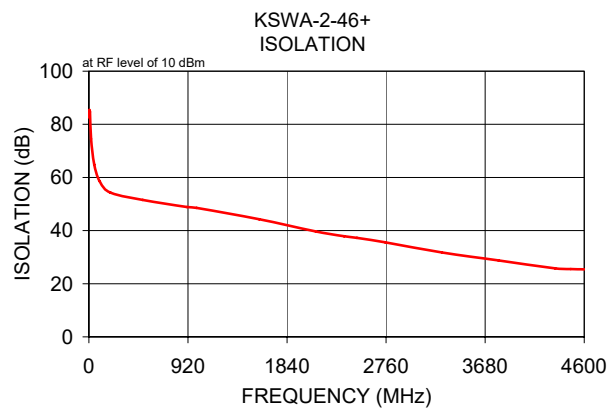
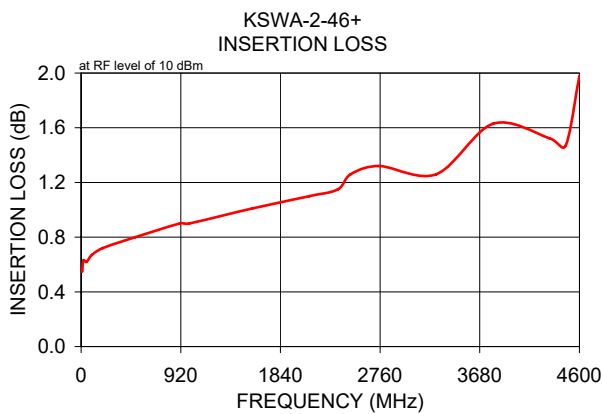

**Notes**

- A. Performance and quality attributes and conditions not expressly stated in this specification document are intended to be excluded and do not form a part of this specification document.
- B. Electrical specifications and performance data contained in this specification document are based on Mini-Circuit's applicable established test performance criteria and measurement instructions.
- C. The parts covered by this specification document are subject to Mini-Circuits standard limited warranty and terms and conditions (collectively, "Standard Terms"); Purchasers of this part are entitled to the rights and benefits contained therein. For a full statement of the Standard Terms and the exclusive rights and remedies thereunder, please visit Mini-Circuits' website at [www.minicircuits.com/MCLStore/terms.jsp](http://www.minicircuits.com/MCLStore/terms.jsp)



# Switch SPDT , 50Ω

# KSWA-2-46+

## Typical Performance Data

FREQUENCY (MHz)	INSERTION LOSS Control @ 0V/-5V (dB) IN-OUT , "ON"	ISOLATION Control @ 0V/-5V (dB) IN-OUT , "OFF"	VSWR (:1)		
			IN	OUT , "ON"	OUT , "OFF"
3	0.55	82.53	1.12	1.12	1.02
5	0.55	85.42	1.12	1.12	1.02
10	0.55	84.71	1.13	1.13	1.02
20	0.63	74.57	1.13	1.12	1.02
50	0.62	64.87	1.12	1.12	1.02
100	0.67	58.56	1.12	1.12	1.02
200	0.72	54.29	1.12	1.11	1.02
500	0.80	51.52	1.13	1.12	1.02
912	0.90	48.87	1.16	1.11	1.04
1000	0.90	48.56	1.17	1.10	1.05
1581	1.01	44.26	1.20	1.04	1.11
2107	1.10	39.70	1.30	1.09	1.14
2370	1.15	37.89	1.31	1.11	1.15
2490	1.26	37.25	1.32	1.14	1.17
2753	1.32	35.59	1.41	1.22	1.23
3279	1.26	31.74	1.44	1.35	1.29
3805	1.63	28.75	1.39	1.41	1.38
4331	1.52	25.75	1.49	1.78	1.65
4474	1.47	25.51	1.57	1.94	1.73
4600	1.98	25.42	1.55	1.87	1.67

## Typical Performance Curves

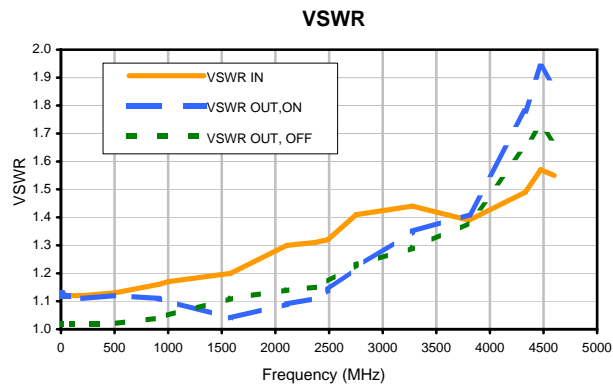
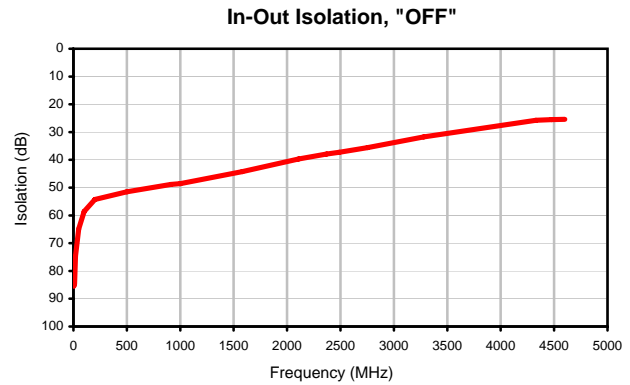
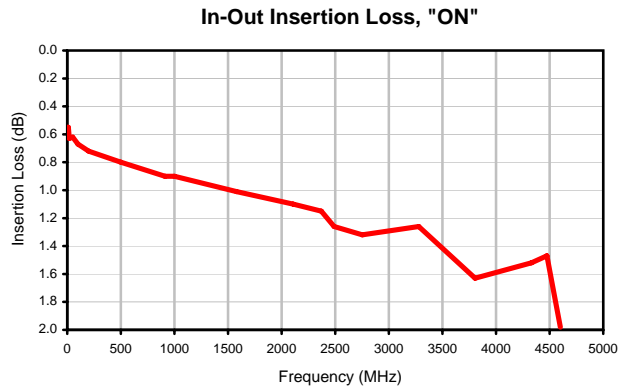

### Outline Dimensions

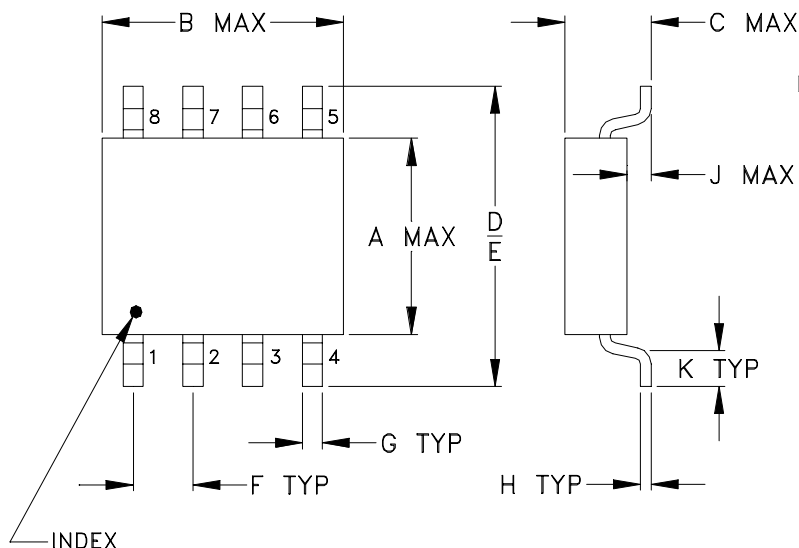

### PCB Land Pattern

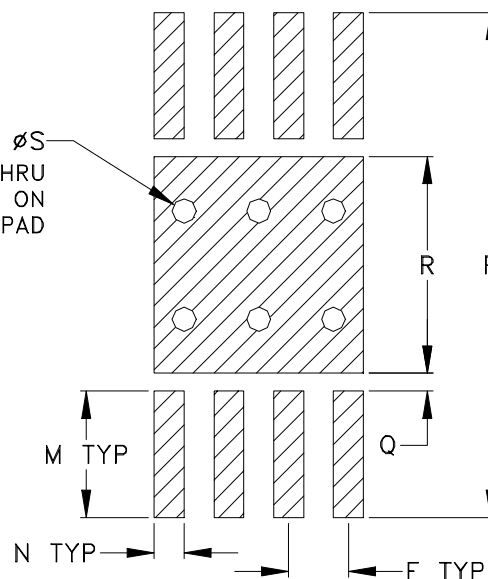

Suggested Layout,  
Tolerance to be within  $\pm .002$

CASE #	A	B	C	D	E	F	G	H	J	K	L	M	N	P
XX112	.180 (4.57)	.180 (4.57)	.070 (1.78)	.400 (10.16)	.350 (8.89)	.050 (1.27)	.015 (0.38)	.005 (0.13)	.005 (0.13)	.070 (1.78)	--	.105 (2.67)	.025 (0.64)	.420 (10.67)

CASE #	Q	R	S	WT. GRAM
XX112	.015 (0.38)	.180 (4.57)	.020 (0.51)	.15

Dimensions are in inches (mm). Tolerances: 2 Pl.  $\pm .01$ ; 3 Pl.  $\pm .005$

#### Notes:

1. Case material: Kovar.
2. Termination Finish: 50  $\mu$  inch (1.27 microns) Gold over 50-350  $\mu$  inch (1.27-8.89 microns) Nickel plate.
3. Special Tolerances: Termination thickness  $\pm .002$  inch.

# Tape & Reel Packaging TR-F19

## DEVICE ORIENTATION IN T&R

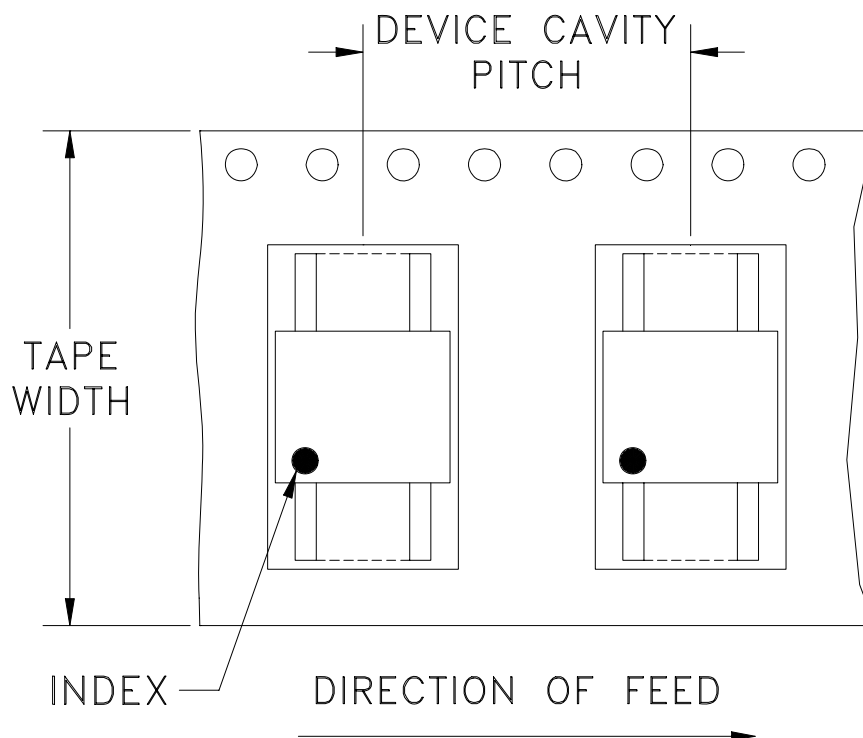

Tape Width, mm	Device Cavity Pitch, mm	Reel Size, inches	Devices per Reel	
16	8	7	Small quantity standards (see note)	20
				50
				100
				200
		7	Standard	500

Note : Please Consult individual model data sheet to determine device per reel availability

Mini-Circuits carrier tape materials provide protection from ESD (Electro-Static Discharge) during handling and transportation. Tapes are static dissipative and comply with industry standards EIA-481/EIA-541.

Go to: [www.minicircuits.com/pages/pdfs/tape.pdf](http://www.minicircuits.com/pages/pdfs/tape.pdf)



INTERNET <http://www.minicircuits.com>

P.O. Box 350166, Brooklyn, New York 11235-0003 (718) 934-4500 Fax (718) 332-4661

Distribution Centers NORTH AMERICA 800-654-7949 • 417-335-5935 • Fax 417-335-5945 • EUROPE 44-1252-832600 • Fax 44-1252-837010

Mini-Circuits ISO 9001 & ISO 14001 Certified

THIRD ANGLE PROJECTION

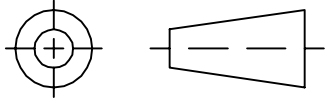

REVISIONS

REV	ECN No.	DESCRIPTION	DATE	DR	AUTH
OR	M100859	NEW RELEASE	10/12/05	MMG	IG
A	M102713	ADDED "...WITH SMOBC"	01/12/06	GT	IL

**SUGGESTED MOUNTING CONFIGURATION  
FOR XX112 CASE STYLE, "eh" PIN CONNECTION.**

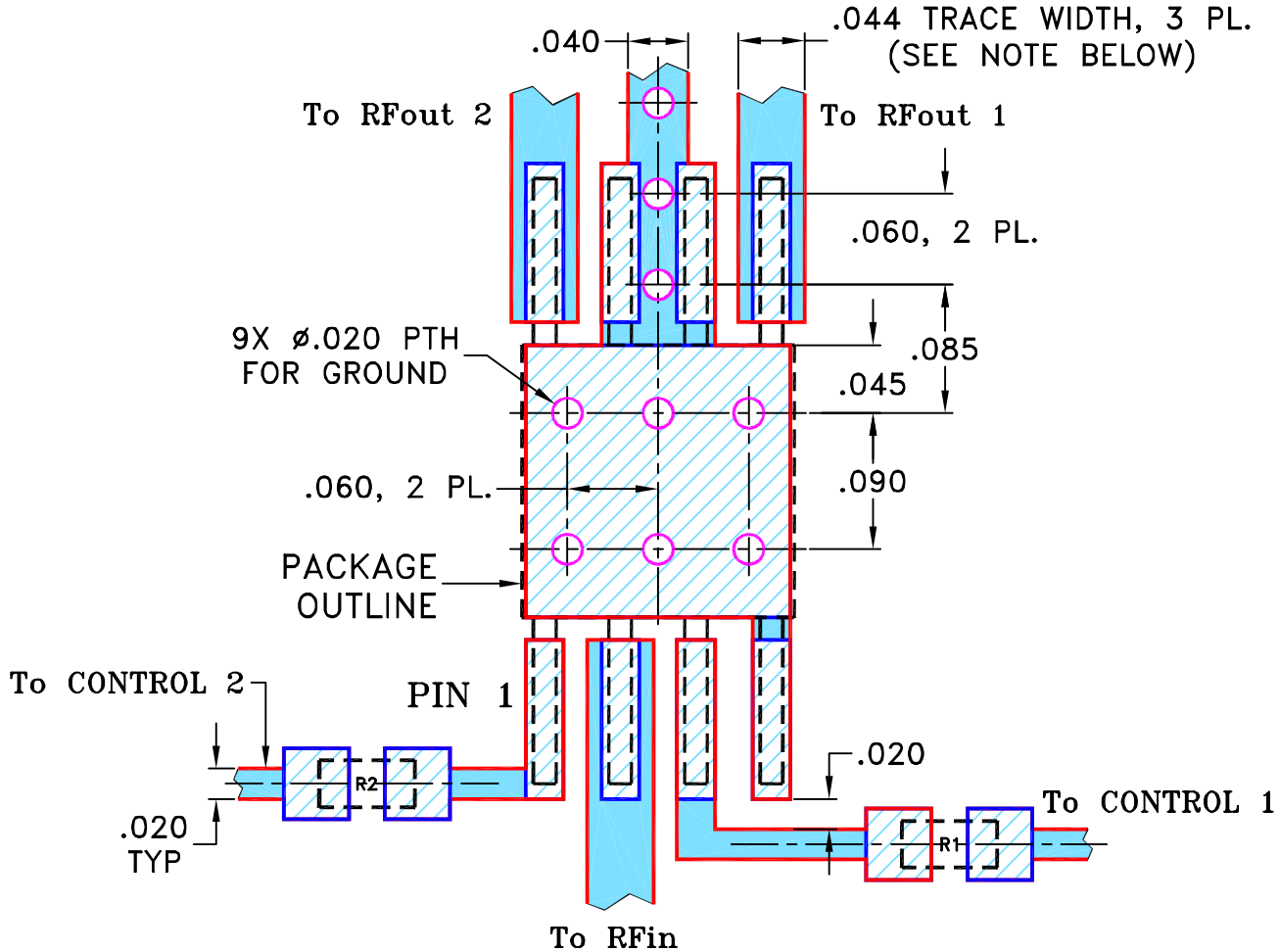

RESISTORS R1, R2: 100 Ohm, 0603 SIZE.

- NOTE: 1. TRACE WIDTH IS SHOWN FOR ROGERS R04350B WITH DIELECTRIC THICKNESS .020" ± .0015"; COPPER: 1/2 OZ. EACH SIDE. FOR OTHER MATERIALS TRACE WIDTH MAY NEED TO BE MODIFIED.  
2. BOTTOM SIDE OF THE PCB IS CONTINUOUS GROUND PLANE.

- DENOTES PCB COPPER LAYOUT WITH SMOBC (SOLDER MASK OVER BARE COPPER)
- DENOTES COPPER LAND PATTERN FREE OF SOLDER MASK

UNLESS OTHERWISE SPECIFIED	INITIALS	DATE
DIMENSIONS ARE IN INCHES	DRAWN MMG	09/22/05
TOLERANCES ON:	CHECKED IL	10/12/05
2 PL DECIMALS ±	APPROVED IG	10/12/05
3 PL DECIMALS ± .005		
ANGLES ±		
FRACTIONS ±		

**Mini-Circuits®** 13 Neptune Avenue  
Brooklyn NY 11235

PL, eh, XX112, KSW(A)-2-46, TB-204

Mini-Circuits®  
THIS DOCUMENT AND ITS CONTENTS ARE THE PROPERTY OF MINI-CIRCUITS. EXCEPT FOR USE EXPRESSLY GRANTED, IN WRITING, TO ITS VENDORS, VENDEE AND THE UNITED STATES GOVERNMENT, MINI-CIRCUITS RESERVES ALL PROPRIETARY DESIGN, USE, MANUFACTURING AND REPRODUCTION RIGHTS THERETO. THESE CONTENTS SHALL NOT BE USED, DUPLICATED OR DISCLOSED TO ANY OUTSIDE PARTY, IN WHOLE OR IN PART, WITHOUT WRITTEN PERMISSION OF MINI-CIRCUITS.

SIZE	CODE IDENT	DRAWING NO:	REV:
A	15542	98-PL-217	A
FILE:	98PL217	SCALE: 8:1	SHEET: 1 OF 1

# Evaluation Board and Circuit

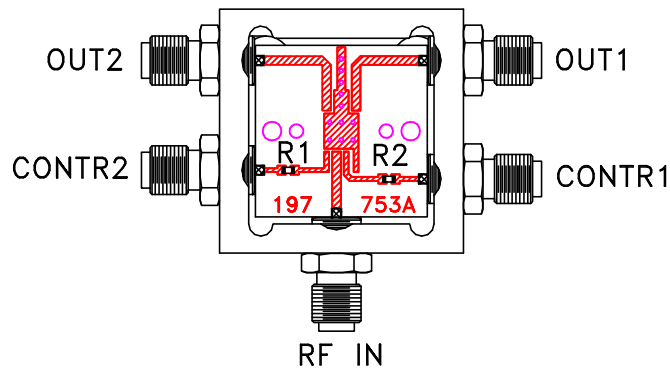

TB-204

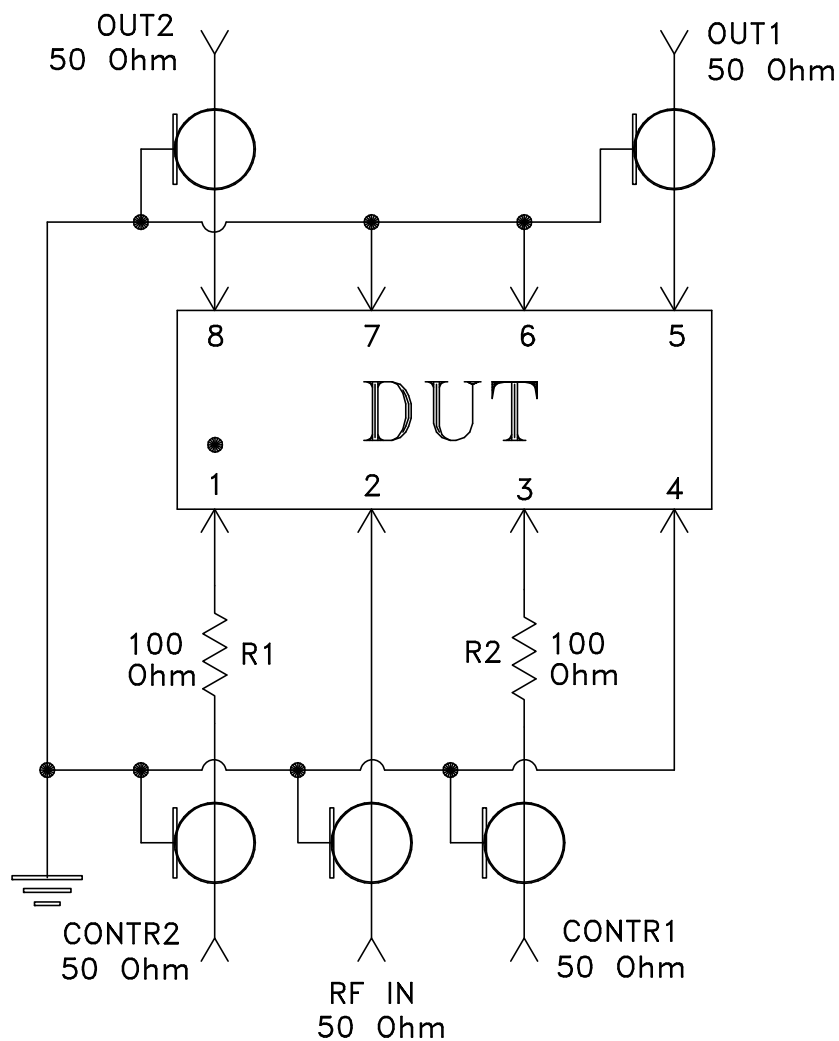

Schematic Diagram

## Notes:

1. SMA Female connectors.
2. PCB Material: Rogers RO4350 or equivalent,  
Dielectric Constant=3.5, Thickness=.020 inch.

 **Mini-Circuits®**





All Mini-Circuits products are manufactured under exacting quality assurance and control standards, and are capable of meeting published specifications after being subjected to any or all of the following physical and environmental test.

Specification	Test/Inspection Condition	Reference/Spec
Operating Temperature	-55° to 100°C Ambient Environment	Individual Model Data Sheet
Storage Temperature	-55° to 150°C Ambient Environment	Individual Model Data Sheet
Thermal Shock	-55° to 100°C, 100 cycles	MIL-STD-202, Method 107, Condition A-3, except +100°C
Humidity	90 to 95% RH, 240 hours, 50°C	MIL-STD-202, Method 103, Condition A, Except 50°C and end-point electrical test done within 12 hours
Solderability	10X Magnification	J-STD-002, 95% Coverage
Vibration (High Frequency)	20g peak, 10-2000 Hz, 12 times in each of three perpendicular directions (total 36)	MIL-STD-202, Method 204, Condition D
Mechanical Shock	50g, 11 ms, 1/2-sine, 18 shocks: 3 each direction, each of 3 axes	MIL-STD-202, Method 213, Condition A
Seal	Gross leak	MIL-STD-202, Method 112, Condition.D
Lead Integrity	Tension parallel to axis of lead, 1.70 x 10 <sup>7</sup> grams-force per square inch of cross-sectional lead area (1.3 kg-force)	MIL-STD-883, Method 2028
Marking Resistance to Solvents	Isopropyl alcohol + mineral spirits at 25°C; terpene defluxer at 25°C; distilled water + proylene glycol monomethyl ether + monoethanolamine at 63°C to 70°C	MIL-STD-202, Method 215