

X2 Frequency Multiplier

50Ω Output 10 to 20 GHz

KSX2-24+



Generic photo used for illustration purposes only

CASE STYLE: HV1195

+RoHS Compliant

The +Suffix identifies RoHS Compliance. See our web site for RoHS Compliance methodologies and qualifications

Maximum Ratings

Operating Temperature	-40°C to 85°C
Storage Temperature	-55°C to 100°C
RF Input, 25°C	100 mW
Permanent damage may occur if any of these limits are exceeded.	

Pin Connections

INPUT	4
OUTPUT	8
50Ω TERMINATE EXT.	2
GROUND	1,3,5,6,7

Outline Drawing

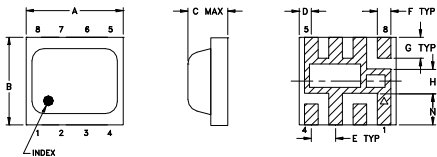

PCB Metal Land Pattern

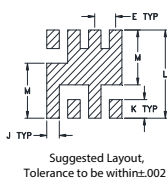

Outline Dimensions (inch/mm)

A	B	C	D	E	F	G		
.200	.180	.087	.025	.050	.028	.043		
5.08	4.57	2.2098	0.64	1.27	0.71	1.09		
H	J	K	L	M	N		wt	
.050	.030	.043	.204	.127	0.065	grams		
1.27	0.76	1.09	5.18	3.23	1.65	0.08		

Demo Board MCL P/N: TB-473+ Suggested PCB Layout (PL-287)

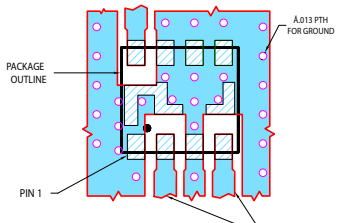

NOTES:

- TRACE WIDTH AND GAP ARE SHOWN FOR ROGERS RO4358B WITH DIELECTRIC THICKNESS .020"/.0015". COPPER: 1/2 OZ EACH SIDE. FOR OTHER MATERIALS TRACE WIDTH AND GAP MAY NEED TO BE MODIFIED.
 - BOTTOM SIDE OF THE PCB IS CONTINUOUS GROUND PLANE.
-

Features

- low conversion loss, 11.5 dB typ.
- high fundamental & harmonic suppression, F1, 30 dBc typ.; F3, 35 dBc typ.; F4, 25 dBc typ.
- LTCC design
- low profile, 0.085"
- aqueous washable

Applications

- synthesizers
- local oscillators

Electrical Specifications

MULTIPLICATION FACTOR	FREQUENCY (GHz)		INPUT POWER (dBm)		CONVERSION LOSS (dB)		*HARMONIC OUTPUT (dBc)						
	F1	F2					F1		F3		F4		
	Input	Output	Min.	Max.	Typ.	Max.	Typ.	Min.	Typ.	Min.	Typ.	Min.	
2	5 - 8	10 - 16	13	16	11.5	15	30	18	35	23	25	15	
			10	13	15	18	21	14	30	18	20	13	
	8 - 10	16 - 20	13	16	12	15	33	20	27	17	50	35	
				10	13	15	18.5	30	16	23	16	40	30

* Harmonics of input frequency below the power level of F2

Typical Performance Data

Input Frequency (MHz)	INPUT RF= 13dBm				INPUT RF= 16dBm			
	Conversion Loss (dB)	Harmonic Output Below F2 (-dBc)			Conversion Loss (dB)	Harmonic Output Below F2 (-dBc)		
	F2	F1	F3	F4	F2	F1	F3	F4
5000.00	12.00	27.66	35.68	21.67	12.50	28.16	34.16	27.66
5500.00	10.48	28.33	35.69	20.40	10.81	29.34	35.52	23.74
5750.00	11.51	27.39	41.04	22.47	12.01	28.45	40.87	24.16
6000.00	10.64	28.35	41.35	22.02	11.48	29.02	47.85	22.52
6525.00	12.00	27.53	47.97	27.17	12.67	28.45	44.30	28.00
6750.00	13.50	25.87	41.12	31.83	12.57	28.77	38.39	28.54
7500.00	12.50	26.19	30.10	49.49	11.83	27.87	41.77	46.76
7800.00	12.37	28.34	29.35	46.17	11.21	34.97	36.01	53.17
8000.00	11.84	33.06	29.35	44.32	11.67	39.81	33.03	56.06
8500.00	13.03	33.87	26.54	57.26	12.36	34.83	26.38	51.43
8700.00	12.33	41.57	28.51	48.32	12.50	34.33	25.85	44.99
9000.00	11.78	35.72	26.68	46.24	11.28	31.39	23.35	47.40
9500.00	11.66	35.01	28.85	54.08	11.16	31.02	27.02	62.92
9700.00	12.33	33.85	32.33	51.30	12.00	29.51	28.50	63.80
10000.00	13.30	29.27	26.97	48.71	13.13	31.03	24.97	54.71

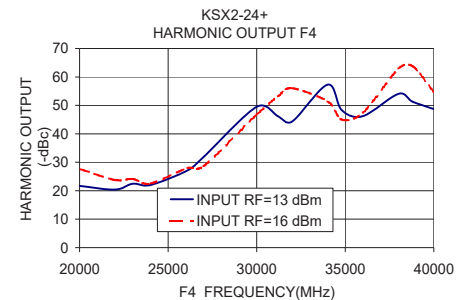
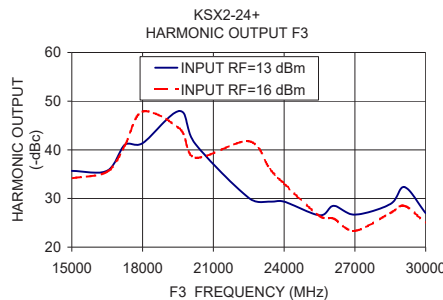
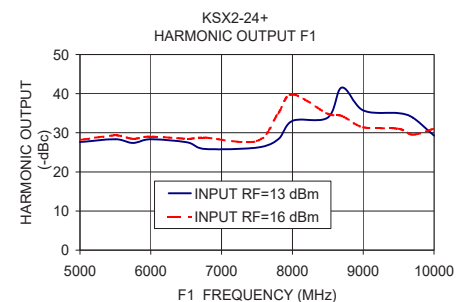
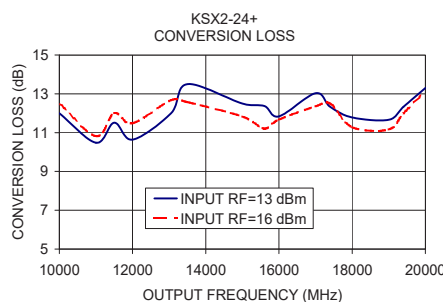

Notes

- Performance and quality attributes and conditions not expressly stated in this specification document are intended to be excluded and do not form a part of this specification document.
- Electrical specifications and performance data contained in this specification document are based on Mini-Circuit's applicable established test performance criteria and measurement instructions.
- The parts covered by this specification document are subject to Mini-Circuits standard limited warranty and terms and conditions (collectively, "Standard Terms"); Purchasers of this part are entitled to the rights and benefits contained therein. For a full statement of the Standard Terms and the exclusive rights and remedies thereunder, please visit Mini-Circuits' website at www.minicircuits.com/MCLStore/terms.jsp



Frequency Multiplier (Doublers)

KSX2-24+

Typical Performance Data

Frequency (MHz)				RF IN = 13dBm			
				Conversion Loss (dB)	Harmonic Output* (-dBc)		
X1 Output	X2 Output	X3 Output	X4 Output	X2 Output	X1 Output	X3 Output	X4 Output
5000.00	10000.00	15000.00	20000.00	12.00	27.66	35.68	21.67
5062.50	10125.00	15187.50	20250.00	11.16	28.35	35.83	22.86
5125.00	10250.00	15375.00	20500.00	10.80	28.67	36.55	24.02
5187.50	10375.00	15562.50	20750.00	10.48	28.86	36.71	22.54
5250.00	10500.00	15750.00	21000.00	10.69	28.81	36.81	20.68
5312.50	10625.00	15937.50	21250.00	11.33	28.00	38.82	20.03
5375.00	10750.00	16125.00	21500.00	11.50	27.73	40.33	20.19
5437.50	10875.00	16312.50	21750.00	11.21	27.96	38.96	19.96
5500.00	11000.00	16500.00	22000.00	10.48	28.33	35.69	20.40
5562.50	11125.00	16687.50	22250.00	9.84	29.01	36.86	21.67
5625.00	11250.00	16875.00	22500.00	10.38	28.31	41.99	23.10
5687.50	11375.00	17062.50	22750.00	10.84	28.15	44.17	23.17
5750.00	11500.00	17250.00	23000.00	11.51	27.39	41.04	22.47
5812.50	11625.00	17437.50	23250.00	12.46	26.38	38.04	21.75
5875.00	11750.00	17625.00	23500.00	11.45	27.23	38.43	22.40
5937.50	11875.00	17812.50	23750.00	10.86	27.81	40.18	22.37
6000.00	12000.00	18000.00	24000.00	10.64	28.35	41.35	22.02
6075.00	12150.00	18225.00	24300.00	11.03	27.87	40.82	20.86
6150.00	12300.00	18450.00	24600.00	11.78	27.23	41.89	20.55
6225.00	12450.00	18675.00	24900.00	11.79	27.38	39.01	20.89
6375.00	12750.00	19125.00	25500.00	11.50	28.01	42.71	24.66
6450.00	12900.00	19350.00	25800.00	11.66	27.86	41.79	26.00
6525.00	13050.00	19575.00	26100.00	12.00	27.53	47.97	27.17
6600.00	13200.00	19800.00	26400.00	12.72	26.95	43.75	30.78
6675.00	13350.00	20025.00	26700.00	12.86	26.42	41.27	30.98
6750.00	13500.00	20250.00	27000.00	13.50	25.87	41.12	31.83
6825.00	13650.00	20475.00	27300.00	12.97	26.40	38.97	33.59
6900.00	13800.00	20700.00	27600.00	13.15	26.03	40.48	32.35
6975.00	13950.00	20925.00	27900.00	12.82	27.01	38.85	38.18
7050.00	14100.00	21150.00	28200.00	13.01	26.55	36.63	36.32
7125.00	14250.00	21375.00	28500.00	12.86	26.65	36.78	37.31
7200.00	14400.00	21600.00	28800.00	12.97	26.21	34.06	38.53
7275.00	14550.00	21825.00	29100.00	13.00	25.35	32.17	38.67
7350.00	14700.00	22050.00	29400.00	12.85	25.84	32.49	37.74
7425.00	14850.00	22275.00	29700.00	12.38	24.98	31.42	40.79
7500.00	15000.00	22500.00	30000.00	12.50	26.19	30.10	49.49
7800.00	15600.00	23400.00	31200.00	12.37	28.34	29.35	46.17
7900.00	15800.00	23700.00	31600.00	11.47	30.87	29.01	50.70
8000.00	16000.00	24000.00	32000.00	11.84	33.06	29.35	44.32
8400.00	16800.00	25200.00	33600.00	12.66	35.72	26.99	48.50
8500.00	17000.00	25500.00	34000.00	13.03	33.87	26.54	57.26
8600.00	17200.00	25800.00	34400.00	13.16	38.52	28.17	56.08
8700.00	17400.00	26100.00	34800.00	12.33	41.57	28.51	48.32
8800.00	17600.00	26400.00	35200.00	12.29	38.37	31.04	46.35
8900.00	17800.00	26700.00	35600.00	12.30	36.72	27.68	44.86
9000.00	18000.00	27000.00	36000.00	11.78	35.72	26.68	46.24
9100.00	18200.00	27300.00	36400.00	11.31	35.40	27.36	47.25
9200.00	18400.00	27600.00	36800.00	11.37	35.86	25.96	49.80
9300.00	18600.00	27900.00	37200.00	11.68	36.00	33.49	52.15
9400.00	18800.00	28200.00	37600.00	11.68	35.82	28.87	57.27
9500.00	19000.00	28500.00	38000.00	11.66	35.01	28.85	54.08
9600.00	19200.00	28800.00	38400.00	12.00	34.36	31.33	52.55
9700.00	19400.00	29100.00	38800.00	12.33	33.85	32.33	51.30
9800.00	19600.00	29400.00	39200.00	12.46	32.94	31.71	48.71
9900.00	19800.00	29700.00	39600.00	12.98	30.57	27.52	48.53
10000.00	20000.00	30000.00	40000.00	13.30	29.27	26.97	48.71

*Harmonic Output below power level of X2 Output.



ISO 9001 ISO 14001 CERTIFIED

P.O. Box 350188, Brooklyn, New York 11235-0003 (718) 934-4500 Fax (718) 332-4661 For detailed performance specs & shopping online see Mini-Circuits web site



The Design Engineers Search Engine Provides ACTUAL Data Instantly From MINI-CIRCUITS At www.minicircuits.com

RF/MICROWAVE COMPONENTS



Frequency Multiplier (Doublers)

KSX2-24+

Typical Performance Data

Frequency (MHz)				RF IN = 16dBm			
				Conversion Loss (dB)		Harmonic Output* (-dBc)	
X1 Output	X2 Output	X3 Output	X4 Output	X2 Output	X1 Output	X3 Output	X4 Output
5000.00	10000.00	15000.00	20000.00	12.50	28.16	34.16	27.66
5062.50	10125.00	15187.50	20250.00	11.67	28.67	35.97	32.18
5125.00	10250.00	15375.00	20500.00	11.30	29.15	34.55	37.03
5187.50	10375.00	15562.50	20750.00	11.81	28.72	31.55	24.39
5250.00	10500.00	15750.00	21000.00	12.02	28.81	34.48	23.02
5312.50	10625.00	15937.50	21250.00	11.50	29.05	36.50	25.86
5375.00	10750.00	16125.00	21500.00	12.16	28.68	33.00	20.53
5437.50	10875.00	16312.50	21750.00	12.21	28.29	33.12	19.63
5500.00	11000.00	16500.00	22000.00	10.81	29.34	35.52	23.74
5562.50	11125.00	16687.50	22250.00	11.18	29.37	40.36	24.84
5625.00	11250.00	16875.00	22500.00	11.04	29.42	37.83	23.28
5687.50	11375.00	17062.50	22750.00	11.83	28.79	37.50	22.34
5750.00	11500.00	17250.00	23000.00	12.01	28.45	40.87	24.16
5812.50	11625.00	17437.50	23250.00	11.62	28.53	40.37	26.08
5875.00	11750.00	17625.00	23500.00	11.78	28.42	37.77	22.57
5937.50	11875.00	17812.50	23750.00	11.69	28.48	40.51	21.53
6000.00	12000.00	18000.00	24000.00	11.48	29.02	47.85	22.52
6075.00	12150.00	18225.00	24300.00	11.88	28.63	40.80	20.85
6150.00	12300.00	18450.00	24600.00	12.28	28.21	42.06	20.21
6225.00	12450.00	18675.00	24900.00	12.29	28.77	46.36	21.54
6375.00	12750.00	19125.00	25500.00	11.83	29.34	44.55	27.16
6450.00	12900.00	19350.00	25800.00	12.17	29.34	42.45	28.32
6525.00	13050.00	19575.00	26100.00	12.67	28.45	44.30	28.00
6600.00	13200.00	19800.00	26400.00	12.71	29.28	37.43	29.72
6675.00	13350.00	20025.00	26700.00	12.35	28.83	36.28	28.75
6750.00	13500.00	20250.00	27000.00	12.57	28.77	38.39	28.54
6825.00	13650.00	20475.00	27300.00	12.38	29.90	35.89	30.28
6900.00	13800.00	20700.00	27600.00	12.22	29.64	37.41	32.13
6975.00	13950.00	20925.00	27900.00	12.06	30.97	38.95	34.72
7050.00	14100.00	21150.00	28200.00	12.16	30.68	36.31	32.18
7125.00	14250.00	21375.00	28500.00	12.17	29.51	36.47	35.59
7200.00	14400.00	21600.00	28800.00	12.13	30.72	36.41	36.58
7275.00	14550.00	21825.00	29100.00	12.16	28.02	34.18	37.80
7350.00	14700.00	22050.00	29400.00	11.85	29.50	42.83	39.99
7425.00	14850.00	22275.00	29700.00	12.20	28.49	40.10	42.42
7500.00	15000.00	22500.00	30000.00	11.83	27.87	41.77	46.76
7800.00	15600.00	23400.00	31200.00	11.21	34.97	36.01	53.17
7900.00	15800.00	23700.00	31600.00	11.64	39.19	33.51	45.03
8000.00	16000.00	24000.00	32000.00	11.67	39.81	33.03	56.06
8400.00	16800.00	25200.00	33600.00	11.66	34.18	27.15	46.00
8500.00	17000.00	25500.00	34000.00	12.36	34.83	26.38	51.43
8600.00	17200.00	25800.00	34400.00	13.16	34.91	27.34	49.42
8700.00	17400.00	26100.00	34800.00	12.50	34.33	25.85	44.99
8800.00	17600.00	26400.00	35200.00	11.96	34.39	26.88	46.85
8900.00	17800.00	26700.00	35600.00	11.80	33.08	23.68	45.86
9000.00	18000.00	27000.00	36000.00	11.28	31.39	23.35	47.40
9100.00	18200.00	27300.00	36400.00	10.64	32.59	25.03	49.58
9200.00	18400.00	27600.00	36800.00	10.87	33.37	23.13	51.13
9300.00	18600.00	27900.00	37200.00	10.84	32.67	34.66	56.49
9400.00	18800.00	28200.00	37600.00	11.02	32.03	27.04	60.93
9500.00	19000.00	28500.00	38000.00	11.16	31.02	27.02	62.92
9600.00	19200.00	28800.00	38400.00	11.50	30.51	27.50	65.72
9700.00	19400.00	29100.00	38800.00	12.00	29.51	28.50	63.80
9800.00	19600.00	29400.00	39200.00	12.29	28.88	29.71	59.21
9900.00	19800.00	29700.00	39600.00	12.64	28.90	27.19	55.36
10000.00	20000.00	30000.00	40000.00	13.13	31.03	24.97	54.71

*Harmonic Output below power level of X2 Output.



ISO 9001 ISO 14001 CERTIFIED

P.O. Box 350188, Brooklyn, New York 11235-0003 (718) 934-4500 Fax (718) 332-4661 For detailed performance specs & shopping online see Mini-Circuits web site



The Design Engineers Search Engine Provides ACTUAL Data Instantly From MINI-CIRCUITS At www.minicircuits.com

RF/MICROWAVE COMPONENTS



Typical Performance Curves

Conversion Loss X2 Output

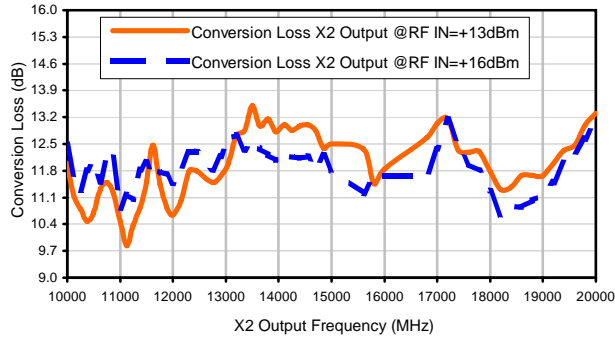

Harmonic X1 Output

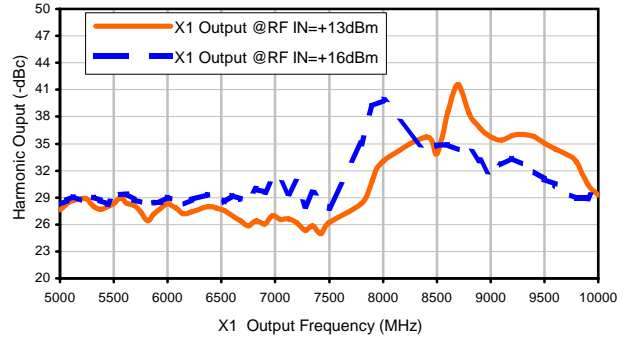

Harmonic X3 Output

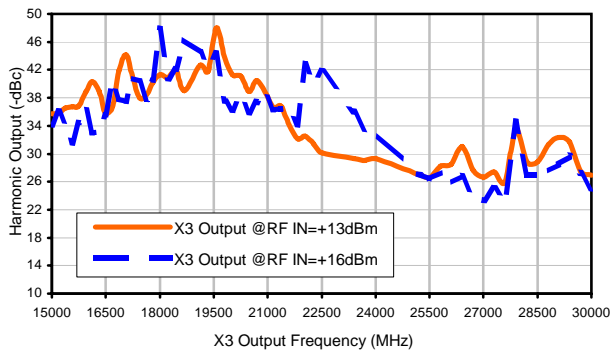

Harmonic X4 Output

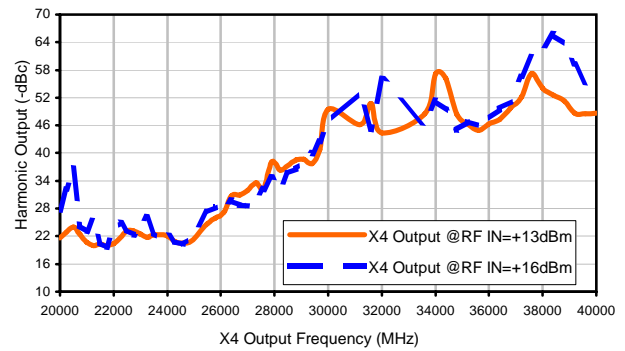

Outline Dimensions

HV1195

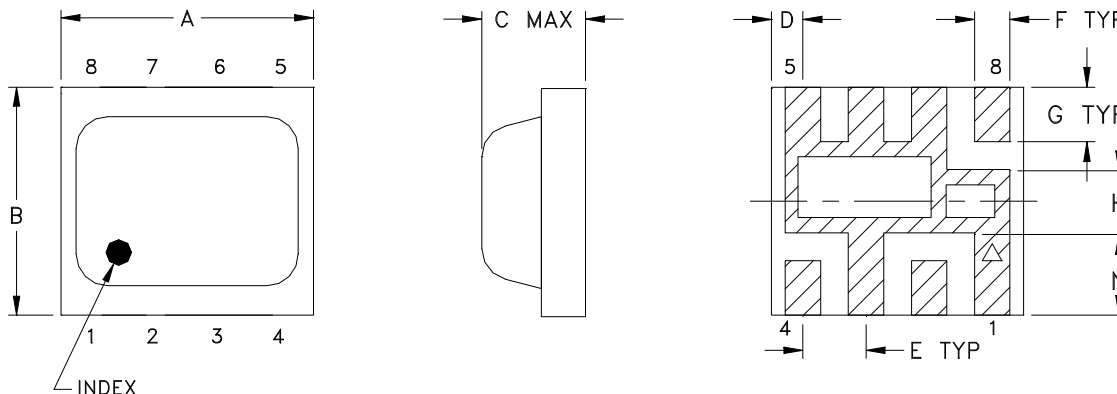

PCB Metal Land Pattern

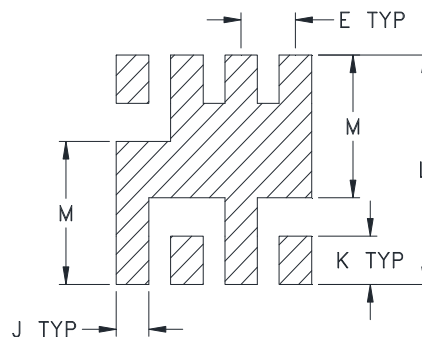

Suggested Layout,
Tolerance to be within ± 0.002

CASE#	A	B	C	D	E	F	G	H	J	K	L	M	N
HV1195	0.200 (5.08)	0.180 (4.57)	0.087 (2.21)	0.025 (0.64)	0.050 (1.27)	0.028 (0.71)	0.043 (1.09)	0.050 (1.27)	0.030 (0.76)	0.043 (1.09)	0.204 (5.18)	0.127 (3.23)	0.065 (1.65)

CASE#	WT, GRAM
HV1195	.08

Dimensions are in inches (mm). Tolerances: 2 Pl. $\pm .01$; 3 Pl. $\pm .005$

Notes:

1. Case material: Plastic encapsulation on Ceramic base.
2. Termination finish: Palladium Silver.



P.O. Box 350166, Brooklyn, New York 11235-0003 (718) 934-4500 Fax (718) 332-4661 For detailed performance specs & shopping online see Mini-Circuits web site



The Design Engineers Search Engine Provides ACTUAL Data Instantly From MINI-CIRCUITS At: www.minicircuits.com

RF/IF MICROWAVE COMPONENTS

Tape & Reel Packaging TR-F82

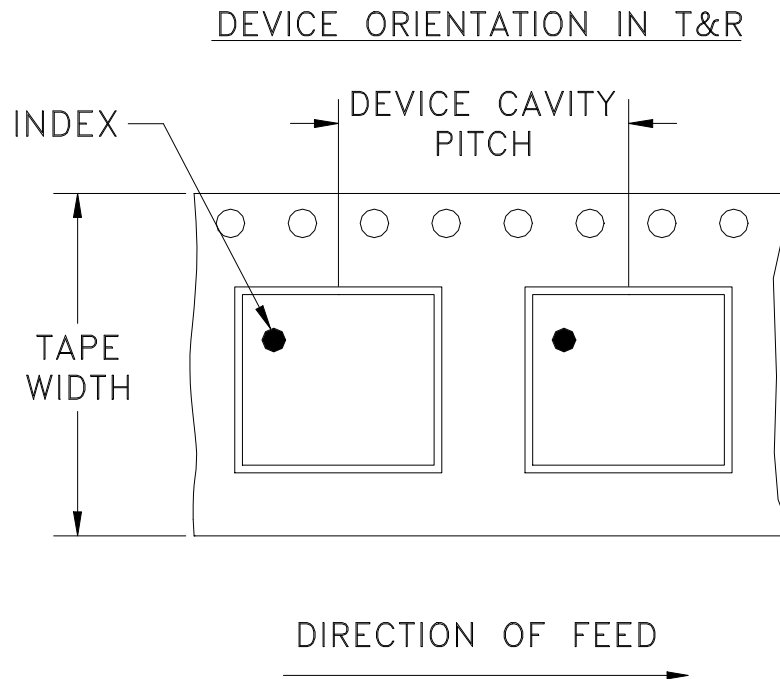

Tape Width, mm	Device Cavity Pitch, mm	Reel Size, inches	Devices per Reel
12	8	7	500

Mini-Circuits carrier tape materials provide protection from ESD (Electro-Static Discharge) during handling and transportation. Tapes are static dissipative and comply with industry standards EIA-481/EIA-541.

Go to: www.minicircuits.com/pages/pdfs/tape.pdf



INTERNET <http://www.minicircuits.com>

P.O. Box 350166, Brooklyn, New York 11235-0003 (718) 934-4500 Fax (718) 332-4661

Distribution Centers NORTH AMERICA 800-654-7949 • 417-335-5935 • Fax 417-335-5945 • EUROPE 44-1252-832600 • Fax 44-1252-837010

Mini-Circuits ISO 9001 & ISO 14001 Certified

THIRD ANGLE PROJECTION

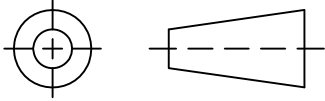

REVISIONS

REV	ECN No.	DESCRIPTION	DATE	DR	AUTH
OR	M116926	NEW RELEASE	04/10/08	MMG	DJ
A	ECO-000060	MODIFIED CASE STYLE	10/16/19	ITG	RB

SUGGESTED MOUNTING CONFIGURATION FOR HV1195 CASE STYLE, "08FM01" PIN CONNECTION

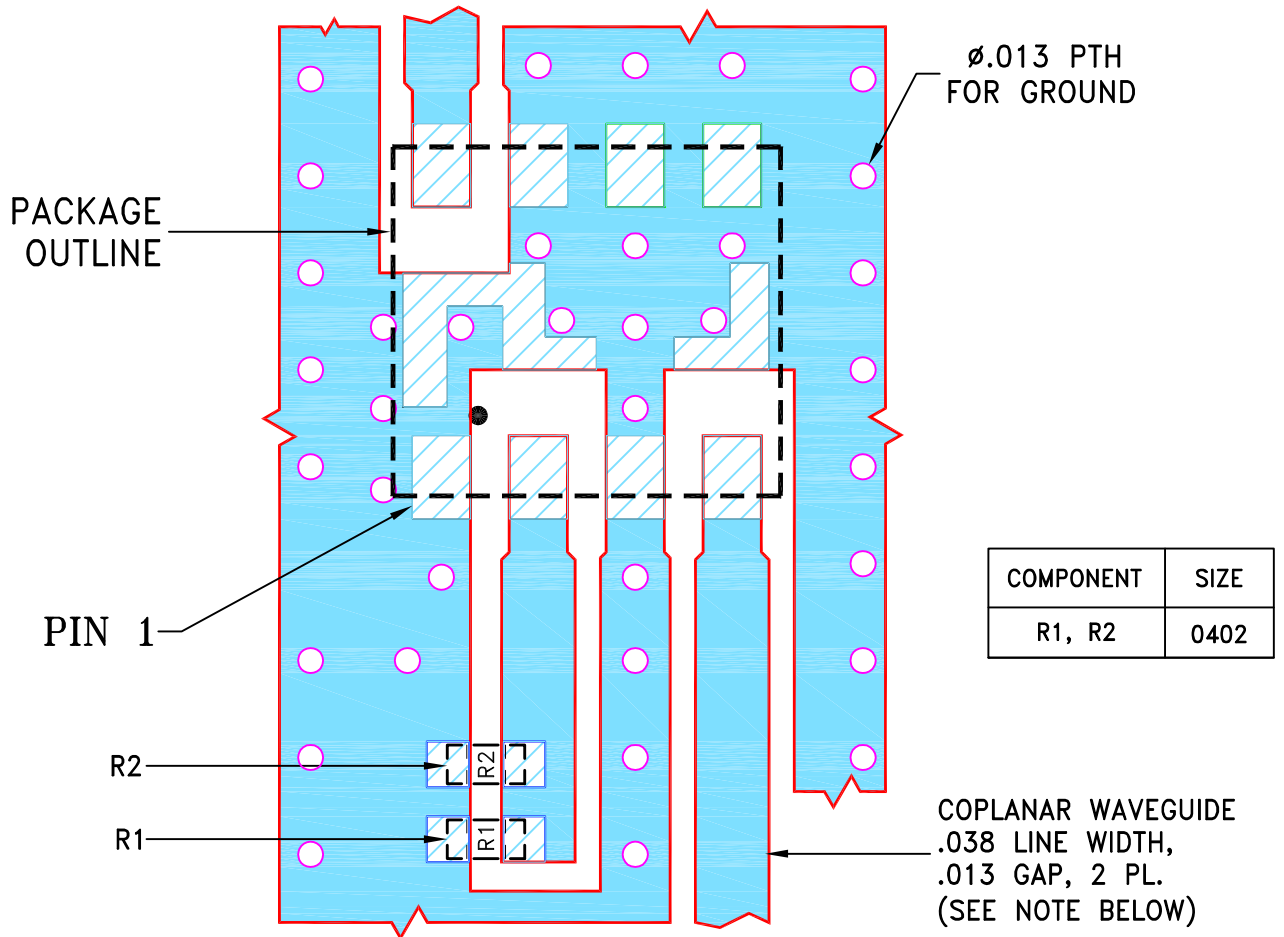

NOTES:

1. TRACE WIDTH AND GAP ARE SHOWN FOR ROGERS RO4350B WITH DIELECTRIC THICKNESS .020"±.0015"; COPPER: 1/2 OZ. EACH SIDE.
FOR OTHER MATERIALS TRACE WIDTH AND GAP MAY NEED TO BE MODIFIED.
2. CHIP COMPONENT FOOT PRINTS SHOWN FOR REFERENCE. FOR COMPONENT VALUES REFER TO TB-473+.
3. BOTTOM SIDE OF THE PCB IS CONTINUOUS GROUND PLANE.

- DENOTES PCB COPPER LAYOUT WITH SMOBC (SOLDER MASK OVER BARE COPPER).
- DENOTES COPPER LAND PATTERN FREE OF SOLDER MASK.

UNLESS OTHERWISE SPECIFIED	INITIALS	DATE
DIMENSIONS ARE IN INCHES	MMG	04/03/08
TOLERANCES ON:	AV	04/10/08
2 PL DECIMALS ±	DJ	04/10/08
3 PL DECIMALS ± .005		
ANGLES ±		
FRACTIONS ±		

Mini-Circuits® 13 Neptune Avenue
Brooklyn NY 11235

PL, 08FM01, HV1195, KSX2, TB-473+

Mini-Circuits®

THIS DOCUMENT AND ITS CONTENTS ARE THE PROPERTY OF MINI-CIRCUITS. EXCEPT FOR USE EXPRESSLY GRANTED, IN WRITING, TO ITS VENDORS, VENDEE AND THE UNITED STATES GOVERNMENT, MINI-CIRCUITS RESERVES ALL PROPRIETARY DESIGN, USE, MANUFACTURING AND REPRODUCTION RIGHTS THERETO. THESE CONTENTS SHALL NOT BE USED, DUPLICATED OR DISCLOSED TO ANY OUTSIDE PARTY, IN WHOLE OR IN PART, WITHOUT WRITTEN PERMISSION OF MINI-CIRCUITS.

ASHEETA1.DWG REV:A DATE:01/12/95

SIZE	CODE IDENT	DRAWING NO:	REV:
A	15542	98-PL-287	A
FILE:	98PL287	SCALE:	SHEET:
		10:1	1 OF 1

Evaluation Board and Circuit

For Pin Connections refer to Data Sheet of the DUT

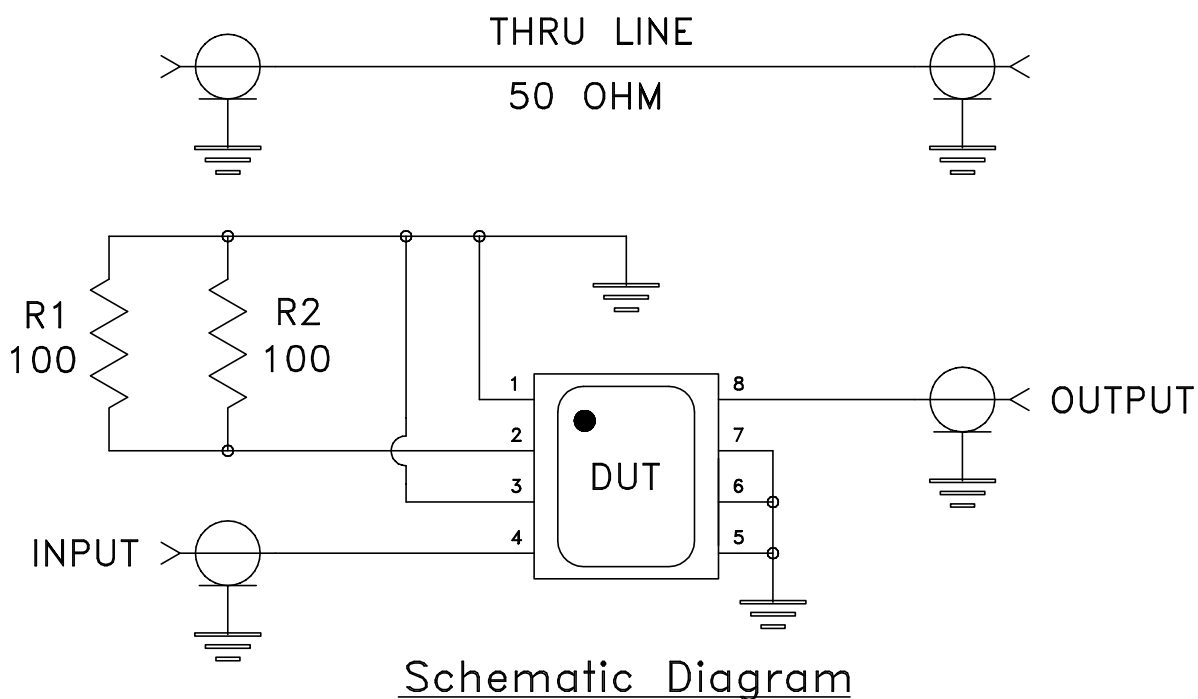
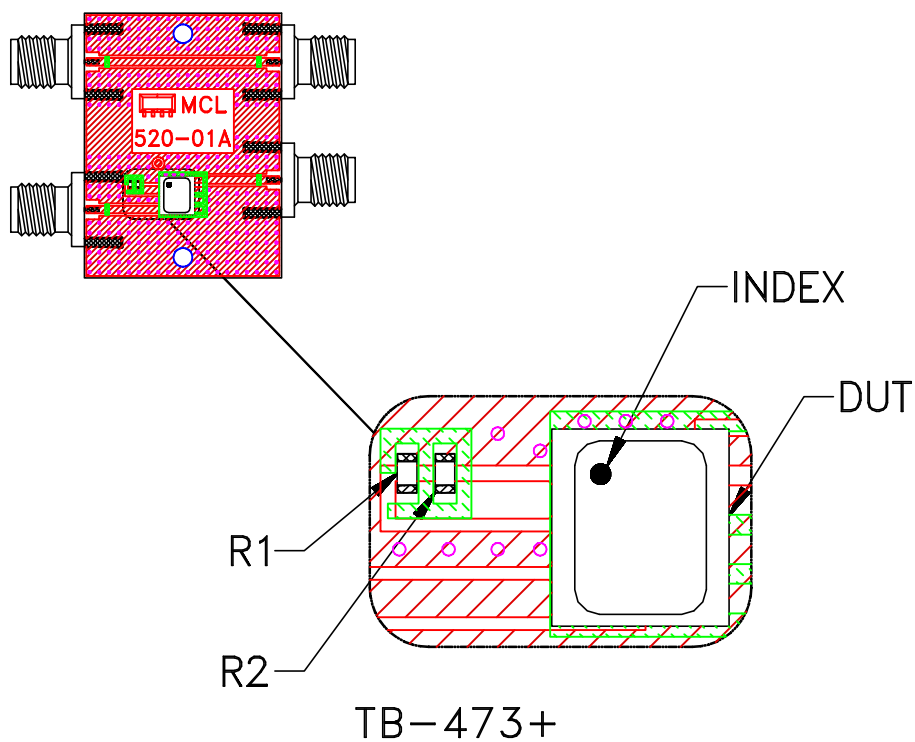

Notes:

1. 50 Ohm SMA Female connectors.
2. PCB Material: R04350 or equivalent,
Dielectric Constant=3.5, Thickness=.020 inch.

 **Mini-Circuits®**

All Mini-Circuits products are manufactured under exacting quality assurance and control standards, and are capable of meeting published specifications after being subjected to any or all of the following physical and environmental test.

Specification	Test/Inspection Condition	Reference/Spec
Operating Temperature	-40° to 85° C Case Temperature	Individual Model Data Sheet
Storage Temperature	-55° to 100° C Ambient Environment	Individual Model Data Sheet
Autoclave	15 psig, 100% RH, 121°C, 96 hours	JESD22-A102-C, Condition C
Thermal Shock	-55° to 100°C, 100 cycles	MIL-STD-202, Method 107, Condition A-3, except +100°C
Solder Reflow Heat	Sn-Pb Eutectic Process: 225°C peak Pb-Free Process: 250°C peak	J-STD-020, Table 4-1, 4-2 and 5-2; Figure 5-1
Solderability	10X Magnification	J-STD-002, Para 4.2.5, Test S, 95% Coverage
Vibration (High Frequency)	20g peak, 10-2000 Hz, 12 times in each of three perpendicular directions (total 36)	MIL-STD-202, Method 204, Condition D
Mechanical Shock	50g, 11 ms, 1/2-sine, 18 shocks: 3 each direction, each of 3 axes	MIL-STD-202, Method 213, Condition A
Marking Resistance to Solvents	Isopropyl alcohol + mineral spirits at 25°C; terpene defluxer at 25°C; distilled water + proylene glycol monomethyl ether + monoethanolamine at 63°C to 70°C	MIL-STD-202, Method 215