

High IP3 Frequency Mixer

LAVI-25VH+

Level 23 (LO Power +23 dBm) 400 to 2500 MHz



Generic photo used for illustration purposes only
CASE STYLE: CK605

+RoHS Compliant

The +Suffix identifies RoHS Compliance. See our web site for RoHS Compliance methodologies and qualifications

Maximum Ratings

| | |
|-----------------------|----------------|
| Operating Temperature | -45°C to 85°C |
| Storage Temperature | -55°C to 100°C |
| LO Power | +25 dBm |
| RF Power | +23 dBm |

Permanent damage may occur if any of these limits are exceeded.

Pin Connections

| | |
|--------|--------------------------------|
| LO | 10 |
| RF | 2 |
| IF | 14 |
| GROUND | 1,3,4,5,6,7,8,9,11,12,13,15,16 |

Features

- very high IP3, 32 dBm typ.
- wideband, 400 to 2500 MHz
- excellent L-R isolation, 50 dB typ. and L-I isolation, 45 dB typ.
- high 1 dB compression, 20 dBm typ.
- shielded metal cover
- aqueous washable
- protected by US Patent 6,807,407

Applications

- cellular/PCS base stations
- ISM applications
- wideband communications
- defense communications

Electrical Specifications (T_{AMB} = 25°C)

| FREQUENCY (MHz) | | | CONVERSION LOSS (dB) | | | RF in at 1dB Compr (dBm) | IP3 (dBm) | LO-RF ISOLATION (dB) | | LO-IF ISOLATION (dB) | |
|-----------------|----------|---------|----------------------|------|------|--------------------------|-----------|----------------------|------|----------------------|------|
| RF | LO | IF | Typ. | σ | Max. | Typ. | Typ. | Typ. | Min. | Typ. | Min. |
| 400-2500 | 650-2800 | 70-1500 | 7.8 | 0.25 | 9.6 | +20 | 32 | 50 | 35 | 45 | 30 |

Typical Performance Data

| Frequency (MHz) | | Conversion Loss (dB) | Isolation L-R (dB) | Isolation L-I (dB) | VSWR RF Port (:1) | VSWR LO Port (:1) | IP3 (dBm) | IF Freq. (MHz) | VSWR IF (:1) |
|-----------------|---------|----------------------|--------------------|--------------------|-------------------|-------------------|-----------|----------------|--------------|
| RF | LO | LO +23dBm | LO +23dBm | LO +23dBm | LO +23dBm | LO +23dBm | LO +23dBm | LO +23dBm | LO +23dBm |
| 400.10 | 650.11 | 7.31 | 56.98 | 55.33 | 1.70 | 2.76 | 31.41 | 70.00 | 1.07 |
| 580.10 | 834.40 | 7.32 | 55.57 | 45.22 | 1.73 | 3.12 | 32.54 | 100.00 | 1.15 |
| 760.10 | 1018.68 | 7.13 | 50.30 | 43.63 | 1.72 | 2.86 | 32.24 | 150.00 | 1.35 |
| 940.10 | 1202.97 | 7.39 | 45.50 | 42.65 | 1.77 | 2.52 | 34.15 | 200.00 | 1.58 |
| 1120.10 | 1387.25 | 7.69 | 43.61 | 38.94 | 2.02 | 2.31 | 32.65 | 250.00 | 1.62 |
| 1300.10 | 1571.54 | 7.58 | 42.32 | 40.68 | 1.99 | 2.32 | 32.17 | 300.00 | 1.71 |
| 1480.10 | 1755.82 | 7.33 | 44.25 | 41.72 | 1.79 | 2.54 | 31.38 | 350.00 | 1.83 |
| 1660.10 | 1940.11 | 7.55 | 46.42 | 45.12 | 1.54 | 3.12 | 30.99 | 450.00 | 2.11 |
| 1840.10 | 2124.40 | 7.76 | 54.12 | 46.33 | 1.43 | 3.71 | 31.99 | 650.00 | 2.26 |
| 2020.10 | 2308.68 | 7.76 | 48.47 | 43.32 | 1.44 | 4.13 | 32.38 | 850.00 | 2.04 |
| 2200.10 | 2492.97 | 7.68 | 41.85 | 36.56 | 1.50 | 4.40 | 32.37 | 1050.00 | 1.82 |
| 2380.10 | 2677.25 | 7.61 | 39.02 | 33.28 | 1.57 | 3.89 | 32.32 | 1250.00 | 1.56 |
| 2500.10 | 2800.11 | 7.91 | 39.71 | 34.21 | 1.70 | 2.47 | 31.79 | 1500.00 | 1.47 |

Outline Drawing

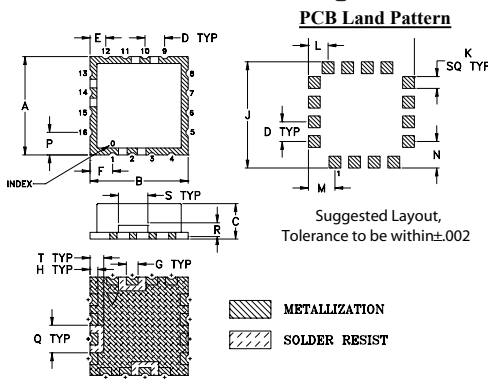

Outline Dimensions (inch/mm)

| A | B | C | D | E | F | G | H | J | K |
|------|-------|-------|-------|-------|-------|-------|-------|-------|-------|
| .500 | .500 | .180 | .100 | .080 | .115 | .060 | .040 | .540 | .060 |
| 12.7 | 12.7 | 4.572 | 2.54 | 2.032 | 2.921 | 1.524 | 1.016 | 13.72 | 1.524 |
| L | M | N | P | Q | R | S | T | wt. | |
| .100 | .135 | .135 | .115 | .140 | .070 | .150 | .070 | grams | |
| 2.54 | 3.429 | 3.429 | 2.921 | 3.556 | 1.778 | 3.81 | 1.778 | 1.0 | |

Demo Board MCL P/N: TB-433+ Suggested PCB Layout (PL-012)

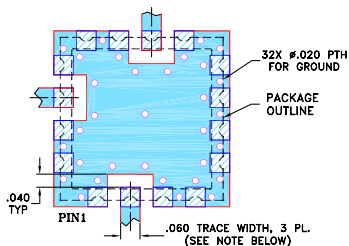

- NOTES: 1. TRACE WIDTH IS SHOWN FOR FR4 WITH DIELECTRIC THICKNESS .030" ± .002"; COPPER: 1/2 OZ. EACH SIDE. FOR OTHER MATERIALS TRACE WIDTH MAY NEED TO BE MODIFIED.
2. BOTTOM SIDE OF THE PCB IS CONTINUOUS GROUND PLANE.
- DENOTES PCB COPPER LAYOUT WITH SMOBC (SOLDER MASK OVER BARE COPPER)
 - DENOTES COPPER LAND PATTERN FREE OF SOLDER MASK

Electrical Schematic

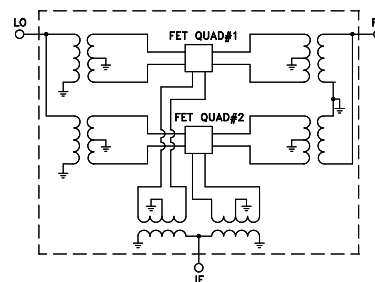

Notes

- Performance and quality attributes and conditions not expressly stated in this specification document are intended to be excluded and do not form a part of this specification document.
- Electrical specifications and performance data contained in this specification document are based on Mini-Circuits' applicable established test performance criteria and measurement instructions.
- The parts covered by this specification document are subject to Mini-Circuits standard limited warranty and terms and conditions (collectively, "Standard Terms"); Purchasers of this part are entitled to the rights and benefits contained therein. For a full statement of the Standard Terms and the exclusive rights and remedies thereunder, please visit Mini-Circuits' website at www.minicircuits.com/MCLStore/terms.jsp



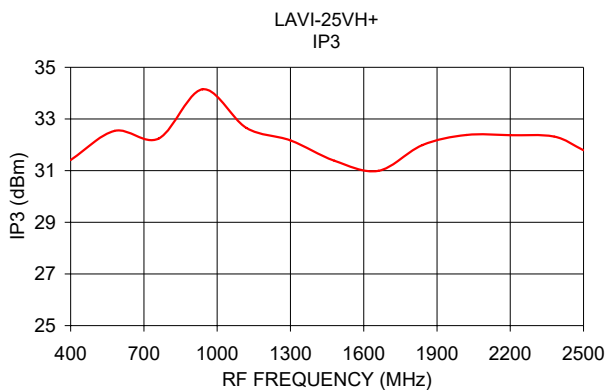
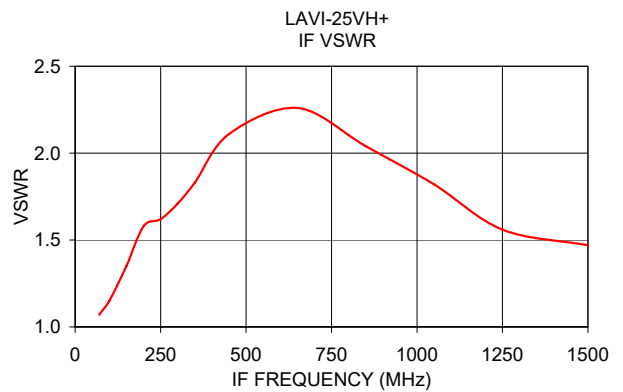
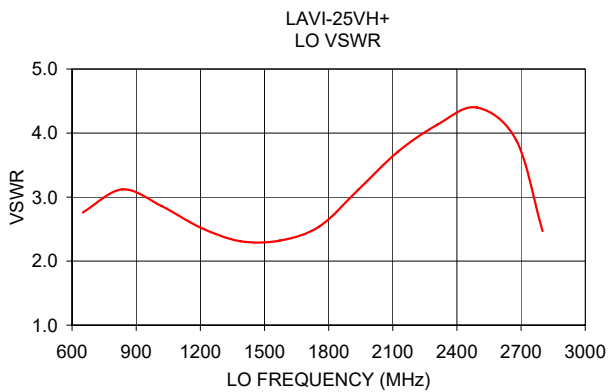
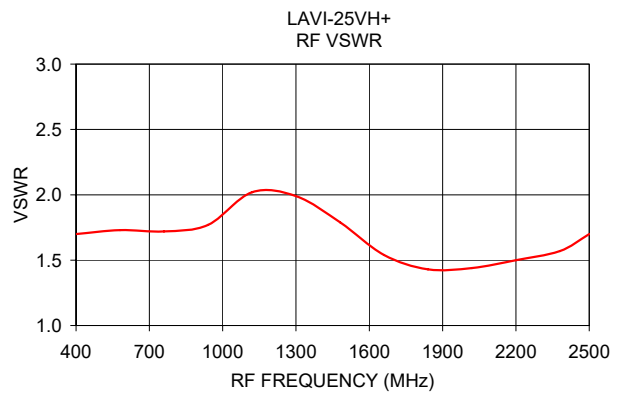
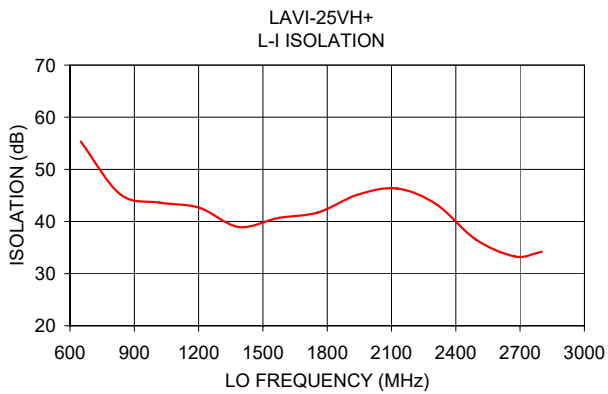
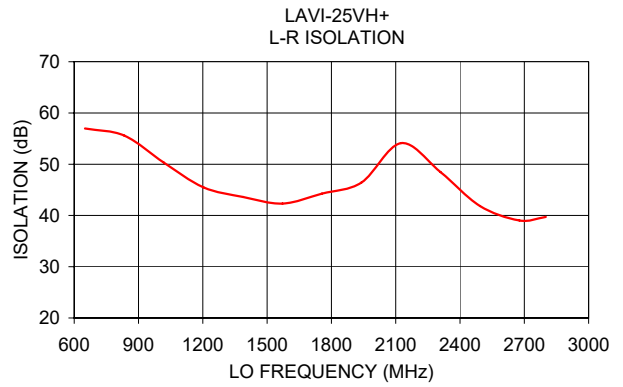
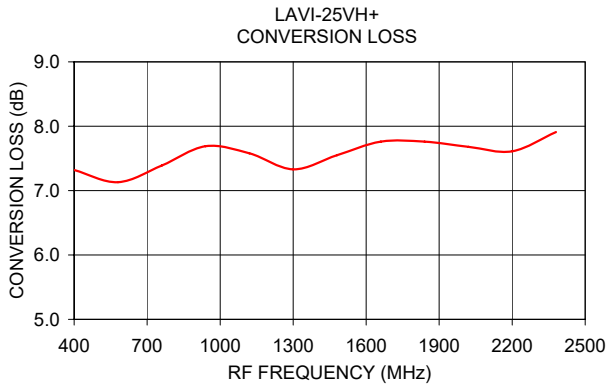

Notes

- A. Performance and quality attributes and conditions not expressly stated in this specification document are intended to be excluded and do not form a part of this specification document.
- B. Electrical specifications and performance data contained in this specification document are based on Mini-Circuit's applicable established test performance criteria and measurement instructions.
- C. The parts covered by this specification document are subject to Mini-Circuits standard limited warranty and terms and conditions (collectively, "Standard Terms"); Purchasers of this part are entitled to the rights and benefits contained therein. For a full statement of the Standard Terms and the exclusive rights and remedies thereunder, please visit Mini-Circuits' website at www.minicircuits.com/MCLStore/terms.jsp



Harmonic Table ($T_{AMB} = 25^{\circ}C$) (Relative to desired IF output)

| RF HARMONICS ORDER | | RF.CAL (-dBc) | | | | | | | | | | |
|--------------------|------|------------------|------|------|------|------|------|------|------|------|------|------|
| | | 0 | 1 | 2 | 3 | 4 | 5 | 6 | 7 | 8 | 9 | 10 |
| 0 | - | - | 9 | 16 | 20 | 23 | 22 | 55 | 31 | 49 | 43 | 53 |
| 1 | - | 36 | +0 | 27 | 16 | 41 | 35 | 54 | 48 | 52 | 57 | 57 |
| 2 | 100 | 45 | 60 | 49 | 62 | 44 | 58 | 51 | 60 | 61 | 68 | 71 |
| 3 | >111 | 82 | 82 | 79 | 67 | 77 | 69 | 88 | 79 | 90 | 94 | 109 |
| 4 | >125 | 102 | 100 | 100 | 91 | 99 | 92 | 93 | 98 | 97 | 108 | 102 |
| 5 | >125 | 119 | 115 | 110 | 105 | 112 | 107 | >117 | 109 | 116 | >119 | >120 |
| 6 | >125 | >118 | >122 | 118 | >121 | 115 | >115 | >117 | 117 | 116 | >123 | >118 |
| 7 | >125 | >119 | >119 | >122 | 123 | >117 | >121 | >116 | >121 | 120 | >123 | >122 |
| 8 | >125 | >120 | >119 | >117 | >123 | >121 | >120 | >122 | >121 | >121 | >121 | 122 |
| 9 | >125 | >119 | >120 | >120 | >119 | >124 | >123 | >121 | >122 | >122 | >120 | >123 |
| 10 | >125 | >120 | >119 | >120 | >119 | >122 | >123 | 122 | >122 | >121 | >122 | >121 |

Test conditions: RF IN: 1250.10 MHz, +.02 dBm.
 LO IN: 1500.01 MHz, +23.00 dBm.
 IF OUT: 249.91 MHz, -7.56 dBm.
 C. LOSS: 7.58 dB.

Notes

- A. Performance and quality attributes and conditions not expressly stated in this specification document are intended to be excluded and do not form a part of this specification document.
- B. Electrical specifications and performance data contained in this specification document are based on Mini-Circuit's applicable established test performance criteria and measurement instructions.
- C. The parts covered by this specification document are subject to Mini-Circuits standard limited warranty and terms and conditions (collectively, "Standard Terms"); Purchasers of this part are entitled to the rights and benefits contained therein. For a full statement of the Standard Terms and the exclusive rights and remedies thereunder, please visit Mini-Circuits' website at www.minicircuits.com/MCLStore/terms.jsp



Frequency Mixer

LAVI-25VH+

Typical Performance Data

| RF (IN) (MHz) | LO (MHz) | CONVERSION LOSS IF FIXED @IF(OUT)=250MHz (dB) | | |
|---------------|----------|---|-------|-------|
| | | @LO (dBm) | | |
| | | +22 | +23 | +24 |
| 10.1 | 260.1 | 9.06 | 8.98 | 8.88 |
| 90.4 | 340.4 | 7.23 | 7.17 | 7.12 |
| 170.7 | 420.7 | 7.24 | 7.20 | 7.17 |
| 250.9 | 500.9 | 7.31 | 7.28 | 7.25 |
| 331.2 | 581.2 | 7.36 | 7.33 | 7.32 |
| 411.5 | 661.5 | 7.46 | 7.42 | 7.40 |
| 491.8 | 741.8 | 7.41 | 7.38 | 7.36 |
| 572.0 | 822.0 | 7.40 | 7.37 | 7.34 |
| 652.3 | 902.3 | 7.38 | 7.34 | 7.32 |
| 732.6 | 982.6 | 7.43 | 7.40 | 7.37 |
| 812.9 | 1062.9 | 7.51 | 7.46 | 7.43 |
| 893.2 | 1143.2 | 7.67 | 7.63 | 7.60 |
| 973.4 | 1223.4 | 7.85 | 7.80 | 7.76 |
| 1053.7 | 1303.7 | 8.00 | 7.94 | 7.90 |
| 1134.0 | 1384.0 | 8.13 | 8.08 | 8.02 |
| 1214.3 | 1464.3 | 8.27 | 8.21 | 8.16 |
| 1294.5 | 1544.5 | 8.36 | 8.30 | 8.23 |
| 1354.8 | 1604.8 | 8.37 | 8.30 | 8.24 |
| 1435.0 | 1685.0 | 8.30 | 8.22 | 8.14 |
| 1495.2 | 1745.2 | 8.22 | 8.15 | 8.07 |
| 1575.5 | 1825.5 | 8.25 | 8.17 | 8.10 |
| 1635.7 | 1885.7 | 8.22 | 8.15 | 8.08 |
| 1716.0 | 1966.0 | 8.19 | 8.11 | 8.05 |
| 1776.2 | 2026.2 | 8.17 | 8.10 | 8.04 |
| 1856.5 | 2106.5 | 8.20 | 8.11 | 8.05 |
| 1916.7 | 2166.7 | 8.16 | 8.07 | 8.01 |
| 1997.0 | 2247.0 | 8.08 | 8.00 | 7.93 |
| 2057.2 | 2307.2 | 8.05 | 7.98 | 7.91 |
| 2137.5 | 2387.5 | 8.05 | 7.97 | 7.90 |
| 2197.7 | 2447.7 | 8.00 | 7.91 | 7.84 |
| 2277.9 | 2527.9 | 7.97 | 7.88 | 7.82 |
| 2338.2 | 2588.2 | 8.08 | 8.00 | 7.95 |
| 2418.4 | 2668.4 | 8.23 | 8.17 | 8.12 |
| 2478.6 | 2728.6 | 8.21 | 8.16 | 8.11 |
| 2558.9 | 2808.9 | 8.37 | 8.32 | 8.28 |
| 2619.1 | 2869.1 | 8.71 | 8.67 | 8.63 |
| 2699.4 | 2949.4 | 9.06 | 9.03 | 9.01 |
| 2759.6 | 3009.6 | 9.22 | 9.19 | 9.18 |
| 2839.9 | 3089.9 | 9.72 | 9.70 | 9.70 |
| 2900.1 | 3150.1 | 10.31 | 10.30 | 10.28 |

| RF (IN) (MHz) | LO (MHz) | IP3 INPUT (dBm) | | |
|---------------|----------|-----------------|-------|-------|
| | | @LO (dBm) | | |
| | | +22 | +23 | +24 |
| 10.1 | 260.1 | 21.49 | 22.49 | 23.46 |
| 90.4 | 340.4 | 24.75 | 26.01 | 27.38 |
| 170.7 | 420.7 | 26.67 | 27.74 | 28.42 |
| 250.9 | 500.9 | 29.56 | 30.25 | 31.05 |
| 331.2 | 581.2 | 30.75 | 31.31 | 31.79 |
| 411.5 | 661.5 | 32.56 | 33.61 | 34.47 |
| 491.8 | 741.8 | 32.42 | 33.16 | 33.92 |
| 572.0 | 822.0 | 32.66 | 33.48 | 34.28 |
| 652.3 | 902.3 | 33.00 | 34.38 | 35.06 |
| 732.6 | 982.6 | 31.63 | 32.42 | 33.41 |
| 812.9 | 1062.9 | 32.46 | 33.35 | 34.33 |
| 893.2 | 1143.2 | 31.19 | 32.06 | 32.81 |
| 973.4 | 1223.4 | 30.51 | 31.56 | 32.64 |
| 1053.7 | 1303.7 | 29.32 | 30.21 | 31.10 |
| 1134.0 | 1384.0 | 29.53 | 30.25 | 31.46 |
| 1214.3 | 1464.3 | 29.50 | 30.31 | 31.06 |
| 1294.5 | 1544.5 | 30.70 | 31.68 | 32.76 |
| 1354.8 | 1604.8 | 30.10 | 30.72 | 31.52 |
| 1435.0 | 1685.0 | 30.86 | 31.75 | 32.86 |
| 1495.2 | 1745.2 | 31.40 | 32.30 | 33.45 |
| 1575.5 | 1825.5 | 32.14 | 33.31 | 34.99 |
| 1635.7 | 1885.7 | 31.08 | 31.86 | 32.87 |
| 1716.0 | 1966.0 | 31.34 | 32.28 | 33.30 |
| 1776.2 | 2026.2 | 31.23 | 32.20 | 33.17 |
| 1856.5 | 2106.5 | 31.56 | 32.61 | 33.63 |
| 1916.7 | 2166.7 | 32.70 | 34.29 | 35.85 |
| 1997.0 | 2247.0 | 32.22 | 33.47 | 34.82 |
| 2057.2 | 2307.2 | 31.76 | 32.70 | 33.79 |
| 2137.5 | 2387.5 | 30.93 | 31.77 | 32.63 |
| 2197.7 | 2447.7 | 33.00 | 34.51 | 36.64 |
| 2277.9 | 2527.9 | 31.13 | 32.37 | 33.37 |
| 2338.2 | 2588.2 | 31.10 | 32.35 | 33.50 |
| 2418.4 | 2668.4 | 30.08 | 30.92 | 31.79 |
| 2478.6 | 2728.6 | 30.31 | 31.23 | 32.34 |
| 2558.9 | 2808.9 | 29.08 | 30.01 | 30.95 |
| 2619.1 | 2869.1 | 30.22 | 31.52 | 32.94 |
| 2699.4 | 2949.4 | 29.51 | 30.86 | 32.23 |
| 2759.6 | 3009.6 | 28.92 | 29.91 | 30.92 |
| 2839.9 | 3089.9 | 28.89 | 30.02 | 30.24 |
| 2900.1 | 3150.1 | 29.49 | 30.52 | 31.21 |



Frequency Mixer

LAVI-25VH+

Typical Performance Data

| IF (OUT) (MHz) | LO (MHz) | CONVERSION LOSS VS. IF FREQUENCY @RF(IN)=1450MHz (dB) | IF (OUT) (MHz) | LO (MHz) | CONVERSION LOSS VS. IF FREQUENCY @RF(IN)=400MHz (dB) | IF (OUT) (MHz) | LO (MHz) | CONVERSION LOSS VS. IF FREQUENCY @RF(IN)=2500.1MHz (dB) |
|----------------|----------|---|----------------|----------|--|----------------|----------|---|
| | | @LO (dBm) | | | @LO (dBm) | | | @LO (dBm) |
| | | +23 | | | +23 | | | +23 |
| 1329.9 | 120.1 | 10.09 | 10.1 | 410.1 | 9.10 | 2270.0 | 230.1 | 10.26 |
| 1259.7 | 190.3 | 9.03 | 90.4 | 490.4 | 6.92 | 2210.0 | 290.1 | 9.92 |
| 1189.5 | 260.5 | 8.68 | 170.6 | 570.6 | 7.19 | 2150.0 | 350.1 | 9.79 |
| 1119.3 | 330.7 | 8.43 | 250.9 | 650.9 | 7.41 | 2090.0 | 410.1 | 9.58 |
| 1049.1 | 400.9 | 8.06 | 331.1 | 731.1 | 7.33 | 2030.0 | 470.1 | 9.51 |
| 978.9 | 471.1 | 7.91 | 411.4 | 811.4 | 7.23 | 1970.0 | 530.1 | 9.22 |
| 908.7 | 541.3 | 8.00 | 491.6 | 891.6 | 7.11 | 1910.0 | 590.1 | 8.99 |
| 838.4 | 611.6 | 7.98 | 571.9 | 971.9 | 7.22 | 1850.0 | 650.1 | 8.96 |
| 768.2 | 681.8 | 7.80 | 652.1 | 1052.1 | 7.32 | 1790.0 | 710.1 | 8.95 |
| 698.0 | 752.0 | 7.89 | 732.4 | 1132.4 | 7.33 | 1730.0 | 770.1 | 8.67 |
| 627.8 | 822.2 | 7.91 | 812.6 | 1212.6 | 7.44 | 1670.0 | 830.1 | 8.62 |
| 557.6 | 892.4 | 7.80 | 892.9 | 1292.9 | 7.48 | 1610.0 | 890.1 | 8.73 |
| 487.4 | 962.6 | 7.76 | 973.1 | 1373.1 | 7.29 | 1550.0 | 950.1 | 8.84 |
| 417.2 | 1032.8 | 7.88 | 1053.4 | 1453.4 | 7.31 | 1490.0 | 1010.1 | 8.77 |
| 347.0 | 1103.0 | 7.96 | 1133.6 | 1533.6 | 7.42 | 1430.0 | 1070.1 | 8.90 |
| 276.8 | 1173.2 | 8.07 | 1213.9 | 1613.9 | 7.29 | 1370.0 | 1130.1 | 8.87 |
| 206.6 | 1243.4 | 8.18 | 1294.1 | 1694.1 | 7.18 | 1310.0 | 1190.1 | 8.83 |
| 136.4 | 1313.6 | 7.90 | 1374.4 | 1774.4 | 7.15 | 1250.0 | 1250.1 | 9.06 |
| 66.2 | 1383.8 | 7.99 | 1454.6 | 1854.6 | 7.06 | 1190.0 | 1310.1 | 8.91 |
| 10.0 | 1460.0 | 9.73 | 1534.9 | 1934.9 | 7.05 | 1130.0 | 1370.1 | 9.02 |
| 139.8 | 1589.8 | 8.13 | 1615.1 | 2015.1 | 6.99 | 1070.0 | 1430.1 | 8.94 |
| 269.6 | 1719.6 | 8.16 | 1695.4 | 2095.4 | 7.02 | 1010.0 | 1490.1 | 9.04 |
| 399.4 | 1849.4 | 7.85 | 1775.6 | 2175.6 | 7.35 | 950.0 | 1550.1 | 9.02 |
| 529.2 | 1979.2 | 7.62 | 1855.9 | 2255.9 | 7.55 | 890.0 | 1610.1 | 9.02 |
| 659.0 | 2109.0 | 7.81 | 1936.1 | 2336.1 | 7.66 | 830.0 | 1670.1 | 8.93 |
| 788.8 | 2238.8 | 7.90 | 2016.4 | 2416.4 | 7.99 | 770.0 | 1730.1 | 8.76 |
| 918.5 | 2368.5 | 8.00 | 2096.6 | 2496.6 | 8.34 | 710.0 | 1790.1 | 8.78 |
| 1048.3 | 2498.3 | 7.87 | 2176.9 | 2576.9 | 8.66 | 650.0 | 1850.1 | 8.82 |
| 1152.2 | 2602.2 | 7.94 | 2257.1 | 2657.1 | 8.88 | 590.0 | 1910.1 | 8.73 |
| 1282.0 | 2732.0 | 7.96 | 2337.4 | 2737.4 | 8.92 | 530.0 | 1970.1 | 8.66 |
| 1385.8 | 2835.8 | 8.14 | 2417.6 | 2817.6 | 8.99 | 470.0 | 2030.1 | 8.66 |
| 1515.6 | 2965.6 | 8.49 | 2497.9 | 2897.9 | 9.17 | 410.0 | 2090.1 | 8.72 |
| 1619.4 | 3069.4 | 8.75 | 2578.2 | 2978.2 | 9.21 | 370.0 | 2130.1 | 8.77 |
| 1749.2 | 3199.2 | 9.12 | 2658.4 | 3058.4 | 9.31 | 310.0 | 2190.1 | 8.73 |
| 1853.1 | 3303.1 | 9.26 | 2738.7 | 3138.7 | 9.38 | 270.0 | 2230.1 | 8.78 |
| 1982.8 | 3432.8 | 9.26 | 2839.0 | 3239.0 | 9.52 | 210.0 | 2290.1 | 8.84 |
| 2086.7 | 3536.7 | 9.45 | 2919.2 | 3319.2 | 9.69 | 170.0 | 2330.1 | 8.56 |
| 2216.5 | 3666.5 | 9.66 | 3019.5 | 3419.5 | 9.90 | 110.0 | 2390.1 | 8.26 |
| 2320.3 | 3770.3 | 9.87 | 3099.8 | 3499.8 | 10.13 | 70.0 | 2430.1 | 8.17 |
| 2450.1 | 3900.1 | 10.46 | 3200.1 | 3600.1 | 10.31 | 10.0 | 2490.1 | 10.39 |

Frequency Mixer

LAVI-25VH+

Typical Performance Data

| LO (MHz) | LO-RF ISOLATION (dB) | | | LO-IF ISOLATION (dB) | | |
|-------------|-------------------------|-------|-------|-------------------------|-------|-------|
| | @LO (dBm) | | | @LO (dBm) | | |
| | +22 | +23 | +24 | +22 | +23 | +24 |
| 260.1 | 45.70 | 45.80 | 45.77 | 43.20 | 43.28 | 43.40 |
| 340.4 | 45.55 | 45.57 | 45.54 | 43.29 | 43.30 | 43.26 |
| 420.7 | 46.11 | 46.05 | 46.14 | 43.49 | 43.45 | 43.48 |
| 500.9 | 46.67 | 46.62 | 46.63 | 43.62 | 43.53 | 43.49 |
| 581.2 | 49.05 | 48.99 | 49.06 | 45.20 | 45.06 | 45.08 |
| 661.5 | 54.04 | 54.00 | 53.84 | 50.37 | 50.36 | 50.12 |
| 741.8 | 62.82 | 62.01 | 60.72 | 60.49 | 60.25 | 59.96 |
| 822.0 | 55.49 | 55.61 | 55.88 | 52.98 | 52.90 | 52.85 |
| 902.3 | 51.47 | 51.61 | 51.76 | 49.63 | 49.78 | 49.88 |
| 982.6 | 48.73 | 48.84 | 48.86 | 47.73 | 47.85 | 47.86 |
| 1062.9 | 46.53 | 46.63 | 46.75 | 46.23 | 46.38 | 46.51 |
| 1143.2 | 44.97 | 45.08 | 45.09 | 44.93 | 45.06 | 45.08 |
| 1223.4 | 43.93 | 44.04 | 44.17 | 43.25 | 43.36 | 43.41 |
| 1303.7 | 43.62 | 43.74 | 43.85 | 41.31 | 41.36 | 41.36 |
| 1384.0 | 42.14 | 42.18 | 42.20 | 38.38 | 38.36 | 38.28 |
| 1464.3 | 44.34 | 44.35 | 44.30 | 40.87 | 41.08 | 41.17 |
| 1544.5 | 43.72 | 43.80 | 43.72 | 42.46 | 42.65 | 42.68 |
| 1604.8 | 44.00 | 44.10 | 44.26 | 42.84 | 43.07 | 43.24 |
| 1685.0 | 44.28 | 44.40 | 44.53 | 41.76 | 41.88 | 41.72 |
| 1745.2 | 44.12 | 44.22 | 44.13 | 41.45 | 41.50 | 41.36 |
| 1825.5 | 43.83 | 43.86 | 43.70 | 42.67 | 42.73 | 42.59 |
| 1885.7 | 44.15 | 43.99 | 44.12 | 43.69 | 43.57 | 43.65 |
| 1966.0 | 43.86 | 43.84 | 43.92 | 44.79 | 44.82 | 44.91 |
| 2026.2 | 44.02 | 44.11 | 44.16 | 45.77 | 45.92 | 45.95 |
| 2106.5 | 44.64 | 44.72 | 44.56 | 47.97 | 48.21 | 48.18 |
| 2166.7 | 46.59 | 46.61 | 46.63 | 51.41 | 51.61 | 51.90 |
| 2247.0 | 50.62 | 50.87 | 51.01 | 57.10 | 56.75 | 56.50 |
| 2307.2 | 51.34 | 51.35 | 51.46 | 49.56 | 49.10 | 48.88 |
| 2387.5 | 47.13 | 47.17 | 47.09 | 43.28 | 43.07 | 42.84 |
| 2447.7 | 44.77 | 44.70 | 44.39 | 40.35 | 40.13 | 39.74 |
| 2527.9 | 43.53 | 43.56 | 43.43 | 37.60 | 37.54 | 37.33 |
| 2588.2 | 43.57 | 43.39 | 43.25 | 36.45 | 36.28 | 36.13 |
| 2668.4 | 44.21 | 44.20 | 44.11 | 35.42 | 35.45 | 35.39 |
| 2728.6 | 44.47 | 44.40 | 44.28 | 35.19 | 35.16 | 35.08 |
| 2808.9 | 44.17 | 44.00 | 43.72 | 35.37 | 35.36 | 35.22 |
| 2869.1 | 42.85 | 42.87 | 42.62 | 35.57 | 35.66 | 35.52 |
| 2949.4 | 41.51 | 41.49 | 41.44 | 36.12 | 36.13 | 36.12 |
| 3009.6 | 40.66 | 40.66 | 40.82 | 36.52 | 36.56 | 36.69 |
| 3089.9 | 39.30 | 39.42 | 39.47 | 37.02 | 37.19 | 37.26 |
| 3150.1 | 38.49 | 38.62 | 38.73 | 37.33 | 37.46 | 37.50 |

| RF (IN) (MHz) | LO (MHz) | RF-IF ISOLATION (dB) | | |
|---------------------|-------------|-------------------------|-------|-------|
| | | @LO (dBm) | | |
| | | +22 | +23 | +24 |
| 10.1 | 260.1 | 12.28 | 12.20 | 12.17 |
| 90.4 | 340.4 | 26.72 | 26.67 | 26.04 |
| 170.7 | 420.7 | 30.96 | 31.07 | 31.49 |
| 250.9 | 500.9 | 33.10 | 33.09 | 33.00 |
| 331.2 | 581.2 | 32.98 | 32.40 | 31.57 |
| 411.5 | 661.5 | 36.71 | 36.61 | 37.06 |
| 491.8 | 741.8 | 35.95 | 35.42 | 34.55 |
| 572.0 | 822.0 | 33.02 | 32.49 | 32.45 |
| 652.3 | 902.3 | 36.02 | 35.43 | 34.70 |
| 732.6 | 982.6 | 33.39 | 32.32 | 30.87 |
| 812.9 | 1062.9 | 37.09 | 36.21 | 35.46 |
| 893.2 | 1143.2 | 38.26 | 36.87 | 34.93 |
| 973.4 | 1223.4 | 40.99 | 38.70 | 35.85 |
| 1053.7 | 1303.7 | 47.79 | 44.41 | 40.87 |
| 1134.0 | 1384.0 | 41.24 | 38.50 | 33.43 |
| 1214.3 | 1464.3 | 44.04 | 43.86 | 41.16 |
| 1294.5 | 1544.5 | 44.07 | 43.68 | 39.50 |
| 1354.8 | 1604.8 | 42.29 | 43.56 | 44.04 |
| 1435.0 | 1685.0 | 52.96 | 51.38 | 35.52 |
| 1495.2 | 1745.2 | 40.38 | 42.30 | 48.19 |
| 1575.5 | 1825.5 | 37.50 | 38.81 | 40.72 |
| 1635.7 | 1885.7 | 35.67 | 36.55 | 38.56 |
| 1716.0 | 1966.0 | 32.44 | 32.63 | 32.81 |
| 1776.2 | 2026.2 | 31.65 | 31.88 | 32.14 |
| 1856.5 | 2106.5 | 30.23 | 30.28 | 30.27 |
| 1916.7 | 2166.7 | 29.42 | 29.42 | 29.40 |
| 1997.0 | 2247.0 | 29.18 | 29.19 | 29.28 |
| 2057.2 | 2307.2 | 28.45 | 28.42 | 28.36 |
| 2137.5 | 2387.5 | 28.32 | 28.25 | 28.19 |
| 2197.7 | 2447.7 | 28.64 | 28.55 | 28.50 |
| 2277.9 | 2527.9 | 29.54 | 29.43 | 29.37 |
| 2338.2 | 2588.2 | 30.17 | 30.02 | 29.88 |
| 2418.4 | 2668.4 | 28.97 | 28.81 | 28.75 |
| 2478.6 | 2728.6 | 26.93 | 26.89 | 26.90 |
| 2558.9 | 2808.9 | 25.45 | 25.38 | 25.21 |
| 2619.1 | 2869.1 | 25.39 | 25.37 | 25.22 |
| 2699.4 | 2949.4 | 26.40 | 26.35 | 26.10 |
| 2759.6 | 3009.6 | 27.19 | 27.03 | 26.66 |
| 2839.9 | 3089.9 | 28.28 | 27.94 | 27.85 |
| 2900.1 | 3150.1 | 29.19 | 28.95 | 28.61 |



Frequency Mixer

LAVI-25VH+

Typical Performance Data

| RF (IN) (MHz) | LO (MHz) | RF VSWR (:1) | | |
|------------------|-------------|-----------------|------|------|
| | | @LO (dBm) | | |
| | | +22 | +23 | +24 |
| 10.1 | 260.1 | 1.85 | 1.88 | 1.92 |
| 90.4 | 340.4 | 1.35 | 1.37 | 1.40 |
| 170.7 | 420.7 | 1.53 | 1.55 | 1.58 |
| 250.9 | 500.9 | 1.67 | 1.69 | 1.70 |
| 331.2 | 581.2 | 1.70 | 1.72 | 1.74 |
| 411.5 | 661.5 | 1.69 | 1.70 | 1.72 |
| 491.8 | 741.8 | 1.67 | 1.68 | 1.69 |
| 572.0 | 822.0 | 1.64 | 1.64 | 1.64 |
| 652.3 | 902.3 | 1.62 | 1.61 | 1.61 |
| 732.6 | 982.6 | 1.65 | 1.64 | 1.63 |
| 812.9 | 1062.9 | 1.81 | 1.79 | 1.78 |
| 893.2 | 1143.2 | 2.04 | 2.02 | 2.00 |
| 973.4 | 1223.4 | 2.26 | 2.24 | 2.22 |
| 1053.7 | 1303.7 | 2.39 | 2.36 | 2.34 |
| 1134.0 | 1384.0 | 2.40 | 2.38 | 2.36 |
| 1214.3 | 1464.3 | 2.38 | 2.36 | 2.33 |
| 1294.5 | 1544.5 | 2.31 | 2.28 | 2.25 |
| 1354.8 | 1604.8 | 2.24 | 2.21 | 2.18 |
| 1435.0 | 1685.0 | 2.13 | 2.10 | 2.07 |
| 1495.2 | 1745.2 | 2.10 | 2.07 | 2.04 |
| 1575.5 | 1825.5 | 1.95 | 1.92 | 1.90 |
| 1635.7 | 1885.7 | 1.86 | 1.83 | 1.81 |
| 1716.0 | 1966.0 | 1.76 | 1.74 | 1.72 |
| 1776.2 | 2026.2 | 1.72 | 1.69 | 1.67 |
| 1856.5 | 2106.5 | 1.69 | 1.67 | 1.65 |
| 1916.7 | 2166.7 | 1.66 | 1.64 | 1.62 |
| 1997.0 | 2247.0 | 1.65 | 1.63 | 1.62 |
| 2057.2 | 2307.2 | 1.64 | 1.63 | 1.62 |
| 2137.5 | 2387.5 | 1.60 | 1.59 | 1.58 |
| 2197.7 | 2447.7 | 1.59 | 1.58 | 1.58 |
| 2277.9 | 2527.9 | 1.60 | 1.60 | 1.60 |
| 2338.2 | 2588.2 | 1.61 | 1.62 | 1.63 |
| 2418.4 | 2668.4 | 1.67 | 1.68 | 1.70 |
| 2478.6 | 2728.6 | 1.74 | 1.76 | 1.78 |
| 2558.9 | 2808.9 | 1.83 | 1.86 | 1.88 |
| 2619.1 | 2869.1 | 1.91 | 1.94 | 1.97 |
| 2699.4 | 2949.4 | 2.07 | 2.10 | 2.13 |
| 2759.6 | 3009.6 | 2.22 | 2.25 | 2.28 |
| 2839.9 | 3089.9 | 2.41 | 2.45 | 2.46 |
| 2900.1 | 3150.1 | 2.53 | 2.57 | 2.59 |

| LO (MHz) | LO VSWR (:1) | | |
|-------------|-----------------|------|------|
| | @LO (dBm) | | |
| | +22 | +23 | +24 |
| 260.1 | 3.67 | 3.67 | 3.67 |
| 340.4 | 3.47 | 3.47 | 3.47 |
| 420.7 | 3.26 | 3.26 | 3.26 |
| 500.9 | 3.04 | 3.04 | 3.03 |
| 581.2 | 2.84 | 2.84 | 2.83 |
| 661.5 | 2.72 | 2.72 | 2.71 |
| 741.8 | 2.71 | 2.71 | 2.70 |
| 822.0 | 2.77 | 2.77 | 2.76 |
| 902.3 | 2.85 | 2.84 | 2.84 |
| 982.6 | 2.91 | 2.91 | 2.91 |
| 1062.9 | 2.95 | 2.95 | 2.95 |
| 1143.2 | 2.95 | 2.96 | 2.96 |
| 1223.4 | 2.93 | 2.93 | 2.93 |
| 1303.7 | 2.88 | 2.87 | 2.87 |
| 1384.0 | 2.83 | 2.82 | 2.82 |
| 1464.3 | 2.80 | 2.79 | 2.78 |
| 1544.5 | 2.78 | 2.78 | 2.77 |
| 1604.8 | 2.78 | 2.78 | 2.78 |
| 1685.0 | 2.79 | 2.79 | 2.79 |
| 1745.2 | 2.79 | 2.78 | 2.77 |
| 1825.5 | 2.85 | 2.84 | 2.84 |
| 1885.7 | 2.92 | 2.92 | 2.92 |
| 1966.0 | 2.95 | 2.95 | 2.94 |
| 2026.2 | 2.93 | 2.92 | 2.90 |
| 2106.5 | 2.98 | 2.98 | 2.97 |
| 2166.7 | 2.99 | 2.98 | 2.98 |
| 2247.0 | 2.89 | 2.88 | 2.87 |
| 2307.2 | 2.83 | 2.82 | 2.80 |
| 2387.5 | 2.73 | 2.72 | 2.72 |
| 2447.7 | 2.61 | 2.61 | 2.61 |
| 2527.9 | 2.46 | 2.45 | 2.44 |
| 2588.2 | 2.37 | 2.37 | 2.36 |
| 2668.4 | 2.29 | 2.28 | 2.28 |
| 2728.6 | 2.25 | 2.25 | 2.25 |
| 2808.9 | 2.23 | 2.23 | 2.22 |
| 2869.1 | 2.22 | 2.21 | 2.20 |
| 2949.4 | 2.26 | 2.25 | 2.25 |
| 3009.6 | 2.31 | 2.31 | 2.31 |
| 3089.9 | 2.33 | 2.33 | 2.33 |
| 3150.1 | 2.32 | 2.31 | 2.31 |

| IF (OUT) (MHz) | IF VSWR @LO=2800MHz (:1) | | |
|-------------------|--------------------------------|------|------|
| | @LO (dBm) | | |
| | +22 | +23 | +24 |
| 10.1 | 1.92 | 1.95 | 1.99 |
| 90.1 | 1.17 | 1.17 | 1.18 |
| 170.1 | 1.57 | 1.58 | 1.58 |
| 250.1 | 1.78 | 1.79 | 1.80 |
| 330.1 | 1.97 | 1.98 | 1.98 |
| 410.1 | 2.25 | 2.25 | 2.26 |
| 490.1 | 2.42 | 2.43 | 2.43 |
| 550.1 | 2.48 | 2.48 | 2.48 |
| 630.1 | 2.48 | 2.48 | 2.47 |
| 690.1 | 2.44 | 2.44 | 2.43 |
| 770.1 | 2.35 | 2.34 | 2.33 |
| 830.1 | 2.22 | 2.20 | 2.18 |
| 910.1 | 2.01 | 1.99 | 1.97 |
| 970.1 | 1.87 | 1.85 | 1.83 |
| 1050.1 | 1.71 | 1.68 | 1.65 |
| 1110.1 | 1.62 | 1.59 | 1.55 |
| 1190.1 | 1.48 | 1.44 | 1.41 |
| 1250.1 | 1.40 | 1.37 | 1.34 |
| 1330.1 | 1.40 | 1.38 | 1.36 |
| 1390.1 | 1.46 | 1.44 | 1.43 |
| 1470.0 | 1.54 | 1.54 | 1.54 |
| 1530.0 | 1.62 | 1.63 | 1.64 |
| 1610.0 | 1.78 | 1.80 | 1.82 |
| 1670.0 | 1.87 | 1.89 | 1.92 |
| 1750.0 | 2.02 | 2.04 | 2.08 |
| 1810.0 | 2.07 | 2.10 | 2.14 |
| 1890.0 | 2.18 | 2.22 | 2.26 |
| 1950.0 | 2.26 | 2.30 | 2.34 |
| 2030.0 | 2.34 | 2.38 | 2.43 |
| 2090.0 | 2.30 | 2.34 | 2.39 |
| 2170.0 | 2.27 | 2.32 | 2.36 |
| 2230.0 | 2.26 | 2.30 | 2.35 |
| 2310.0 | 2.18 | 2.21 | 2.25 |
| 2370.0 | 2.20 | 2.24 | 2.28 |
| 2450.0 | 2.21 | 2.24 | 2.28 |
| 2510.0 | 2.12 | 2.15 | 2.18 |
| 2590.0 | 2.06 | 2.09 | 2.12 |
| 2650.0 | 2.10 | 2.13 | 2.15 |
| 2730.0 | 2.11 | 2.13 | 2.16 |
| 2790.0 | 2.35 | 2.38 | 2.41 |

Frequency Mixer

LAVI-25VH+

Harmonics Tables

RF HARMONICS ORDER

| | (-dBm) | (-dBc) | | | | | | | | | | |
|----|--------|--------|-----|-----|-----|-----|-----|-----|-----|-----|-----|-----|
| 0 | - | - | 18 | 24 | 26 | 31 | 35 | 46 | 55 | 45 | 51 | 69 |
| 1 | - | 28 | +0 | 27 | 15 | 40 | 35 | 53 | 45 | 50 | 51 | 56 |
| 2 | 65 | 44 | 66 | 47 | 53 | 36 | 56 | 40 | 68 | 47 | 73 | 56 |
| 3 | >90 | 76 | 59 | 67 | 56 | 65 | 53 | 71 | 60 | 71 | 70 | 76 |
| 4 | >90 | 84 | >87 | 74 | 82 | 74 | 85 | 75 | >87 | 74 | 80 | 79 |
| 5 | >90 | 85 | >87 | >87 | >87 | >87 | 84 | >87 | 82 | >87 | 81 | >87 |
| 6 | 88 | >87 | 84 | >87 | 82 | 80 | 85 | >87 | >87 | >87 | >87 | >87 |
| 7 | >90 | >87 | >87 | >87 | >87 | >87 | >87 | >87 | >87 | >87 | >87 | 86 |
| 8 | >90 | >87 | >87 | 86 | 85 | >87 | >87 | >87 | >87 | 84 | >87 | >87 |
| 9 | 89 | >87 | 83 | >87 | >87 | 86 | >87 | 86 | 84 | >87 | >87 | 86 |
| 10 | >90 | >87 | >87 | 86 | >87 | 79 | >87 | >87 | 83 | >87 | >87 | 86 |
| | RF CAL | 0 | 1 | 2 | 3 | 4 | 5 | 6 | 7 | 8 | 9 | 10 |

LO HARMONICS ORDER

Test conditions: RF IN: 1450 MHz; 5.00 dBm.
 LO IN: 1650 MHz; +23.00 dBm
 IF OUT: 200 MHz; -3.44 dBm

RF HARMONICS ORDER

| | (-dBm) | (-dBc) | | | | | | | | | | |
|----|--------|--------|-----|-----|----|-----|----|----|----|----|----|----|
| 0 | - | - | 26 | 28 | 33 | 33 | 46 | 40 | 51 | 44 | 61 | 68 |
| 1 | - | 29 | +0 | 30 | 18 | 42 | 39 | 56 | 43 | 62 | 60 | 77 |
| 2 | 45 | 37 | 56 | 39 | 44 | 28 | 49 | 34 | 65 | 47 | 61 | 62 |
| 3 | 88 | 52 | 44 | 53 | 34 | 47 | 33 | 53 | 44 | 58 | 69 | 65 |
| 4 | >90 | 58 | 61 | 62 | 65 | 56 | 62 | 51 | 69 | 48 | 75 | 56 |
| 5 | >90 | 70 | 68 | 67 | 56 | 67 | 59 | 72 | 52 | 70 | 55 | 68 |
| 6 | 90 | 73 | 77 | 81 | 81 | 70 | 78 | 87 | 80 | 66 | 77 | 61 |
| 7 | 87 | 80 | 78 | 79 | 75 | 79 | 65 | 78 | 66 | 83 | 68 | 88 |
| 8 | 86 | 91 | 83 | 88 | 81 | 80 | 85 | 71 | 84 | 73 | 83 | 70 |
| 9 | 90 | 96 | 94 | 95 | 90 | >96 | 82 | 92 | 80 | 95 | 75 | 85 |
| 10 | >90 | 93 | >96 | >96 | 87 | 91 | 87 | 82 | 85 | 80 | 82 | 79 |
| | RF CAL | 0 | 1 | 2 | 3 | 4 | 5 | 6 | 7 | 8 | 9 | 10 |

LO HARMONICS ORDER

Test conditions: RF IN: 1450 MHz; 15.00 dBm.
 LO IN: 1650 MHz; +23.00 dBm
 IF OUT: 200 MHz; 6.35 dBm

- Notes: 1. All Harmonics are in (dBc) relative to IF OUTPUT.
 2. + entry denotes harmonics are in (dBc) above IF OUTPUT.
 3. RF Cal represent the Harmonics level of the RF input signal to the mixer.

REV. X3
 LAVI-25VH+
 101012
 Page 5 of 5



IF/RF MICROWAVE COMPONENTS • ISO 9001 ISO 14001 AS9100 CERTIFIED • RoHS compliant
 P.O. Box 350166, Brooklyn, New York 11235-0006 (718) 934-4500 Fax (718) 332-4661



The Design Engineers Search Engine finds the model you need, Instantly • For detailed performance specs & shopping online see



Frequency Mixer

LAVI-25VH+

Typical Performance Curves

Conversion Loss @ IF=250MHz

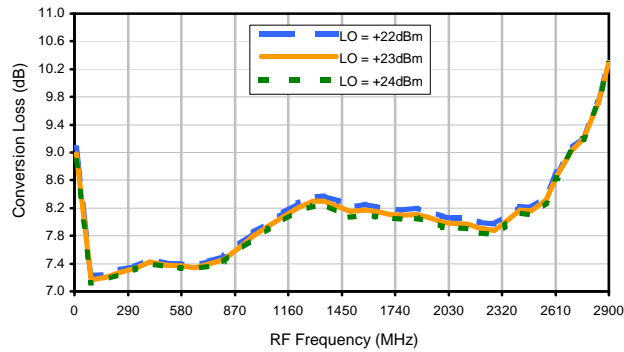

Conversion Loss vs. LO @ RF=1450MHz

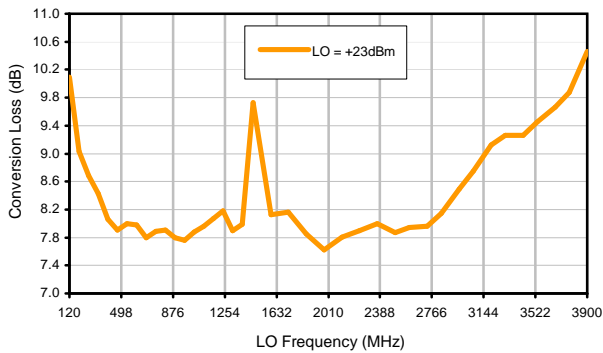

Conversion Loss vs. IF @ RF=1450MHz

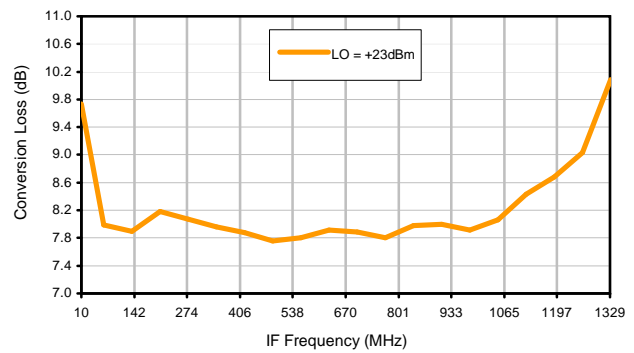

Conversion Loss vs. IF @ RF=400MHz

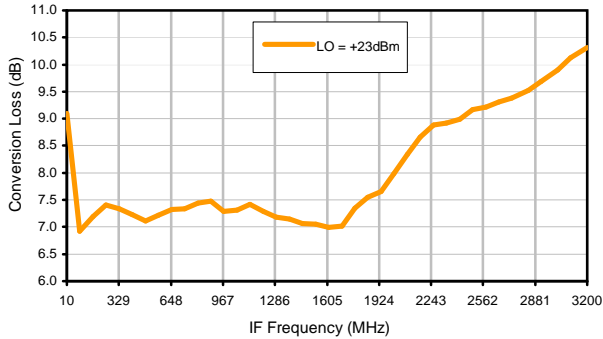

Conversion Loss vs. IF @ RF=2500.1MHz

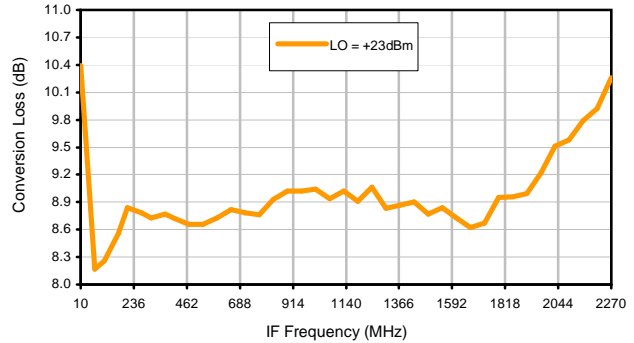

IP3 Input

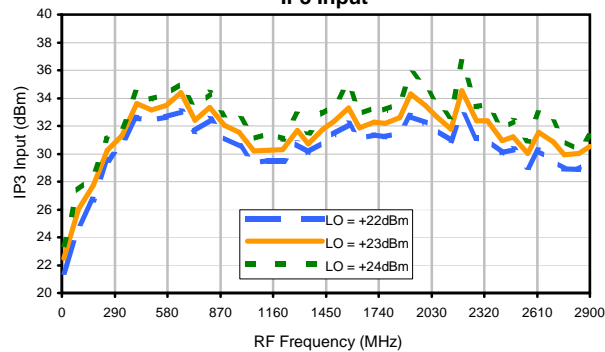

Typical Performance Curves

LO-RF Isolation

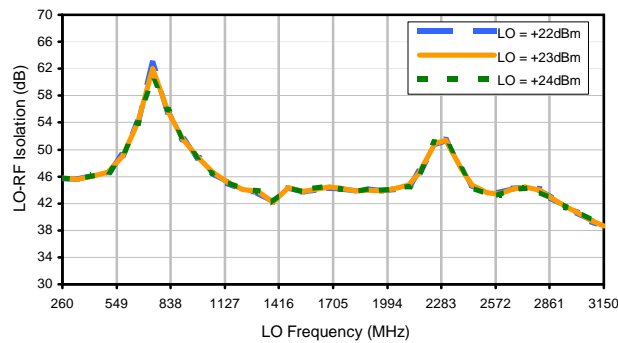

LO-IF Isolation

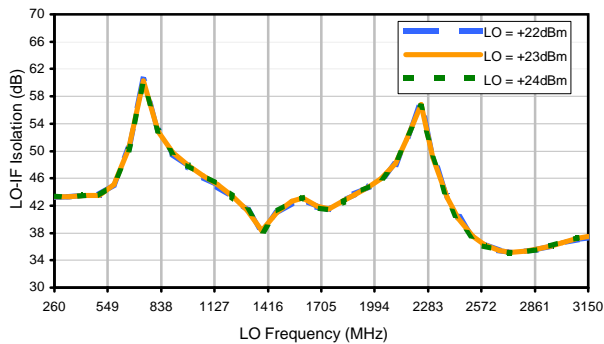

RF-IF Isolation

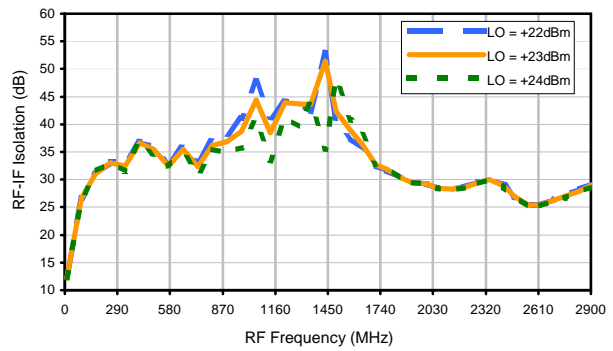

RF VSWR

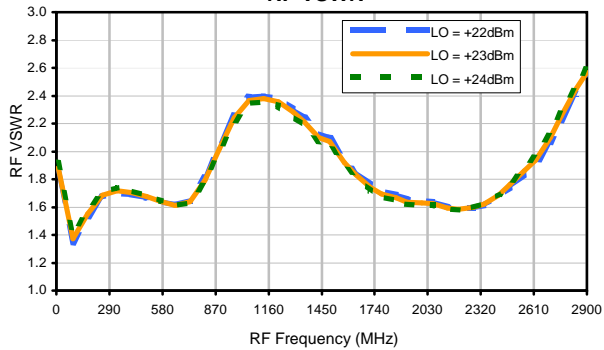

LO VSWR

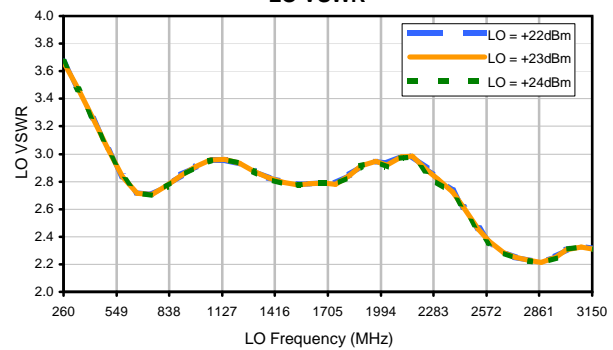

IF VSWR

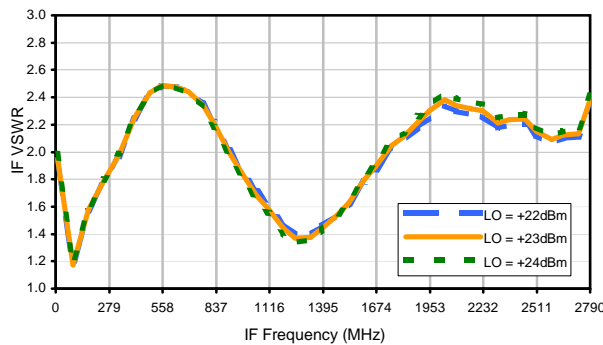

Frequency Mixer

LAVI-25VH+

Harmonics Tables

RF HARMONICS ORDER

| | (-dBm) | (-dBc) | | | | | | | | | | |
|----|--------|--------|-----|-----|-----|-----|-----|-----|-----|-----|-----|-----|
| 0 | - | - | 18 | 24 | 26 | 31 | 35 | 46 | 55 | 45 | 51 | 69 |
| 1 | - | 28 | +0 | 27 | 15 | 40 | 35 | 53 | 45 | 50 | 51 | 56 |
| 2 | 65 | 44 | 66 | 47 | 53 | 36 | 56 | 40 | 68 | 47 | 73 | 56 |
| 3 | >90 | 76 | 59 | 67 | 56 | 65 | 53 | 71 | 60 | 71 | 70 | 76 |
| 4 | >90 | 84 | >87 | 74 | 82 | 74 | 85 | 75 | >87 | 74 | 80 | 79 |
| 5 | >90 | 85 | >87 | >87 | >87 | >87 | 84 | >87 | 82 | >87 | 81 | >87 |
| 6 | 88 | >87 | 84 | >87 | 82 | 80 | 85 | >87 | >87 | >87 | >87 | >87 |
| 7 | >90 | >87 | >87 | >87 | >87 | >87 | >87 | >87 | >87 | >87 | >87 | 86 |
| 8 | >90 | >87 | >87 | 86 | 85 | >87 | >87 | >87 | >87 | 84 | >87 | >87 |
| 9 | 89 | >87 | 83 | >87 | >87 | 86 | >87 | 86 | 84 | >87 | >87 | 86 |
| 10 | >90 | >87 | >87 | 86 | >87 | 79 | >87 | >87 | 83 | >87 | >87 | 86 |
| | RF CAL | 0 | 1 | 2 | 3 | 4 | 5 | 6 | 7 | 8 | 9 | 10 |

LO HARMONICS ORDER

Test conditions: RF IN: 1450 MHz; 5.00 dBm.
 LO IN: 1650 MHz; +23.00 dBm
 IF OUT: 200 MHz; -3.44 dBm

RF HARMONICS ORDER

| | (-dBm) | (-dBc) | | | | | | | | | | |
|----|--------|--------|-----|-----|----|-----|----|----|----|----|----|----|
| 0 | - | - | 26 | 28 | 33 | 33 | 46 | 40 | 51 | 44 | 61 | 68 |
| 1 | - | 29 | +0 | 30 | 18 | 42 | 39 | 56 | 43 | 62 | 60 | 77 |
| 2 | 45 | 37 | 56 | 39 | 44 | 28 | 49 | 34 | 65 | 47 | 61 | 62 |
| 3 | 88 | 52 | 44 | 53 | 34 | 47 | 33 | 53 | 44 | 58 | 69 | 65 |
| 4 | >90 | 58 | 61 | 62 | 65 | 56 | 62 | 51 | 69 | 48 | 75 | 56 |
| 5 | >90 | 70 | 68 | 67 | 56 | 67 | 59 | 72 | 52 | 70 | 55 | 68 |
| 6 | 90 | 73 | 77 | 81 | 81 | 70 | 78 | 87 | 80 | 66 | 77 | 61 |
| 7 | 87 | 80 | 78 | 79 | 75 | 79 | 65 | 78 | 66 | 83 | 68 | 88 |
| 8 | 86 | 91 | 83 | 88 | 81 | 80 | 85 | 71 | 84 | 73 | 83 | 70 |
| 9 | 90 | 96 | 94 | 95 | 90 | >96 | 82 | 92 | 80 | 95 | 75 | 85 |
| 10 | >90 | 93 | >96 | >96 | 87 | 91 | 87 | 82 | 85 | 80 | 82 | 79 |
| | RF CAL | 0 | 1 | 2 | 3 | 4 | 5 | 6 | 7 | 8 | 9 | 10 |

LO HARMONICS ORDER

Test conditions: RF IN: 1450 MHz; 15.00 dBm.
 LO IN: 1650 MHz; +23.00 dBm
 IF OUT: 200 MHz; 6.35 dBm

- Notes: 1. All Harmonics are in (dBc) relative to IF OUTPUT.
 2. + entry denotes harmonics are in (dBc) above IF OUTPUT.
 3. RF Cal represent the Harmonics level of the RF input signal to the mixer.

REV. X3
 LAVI-25VH+
 101012
 Page 3 of 3

Outline Dimensions

PCB Land Pattern

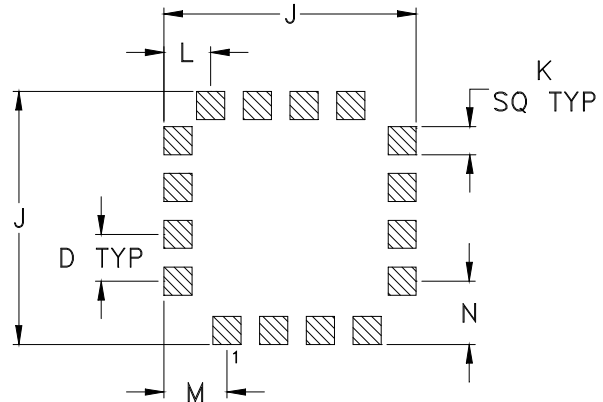
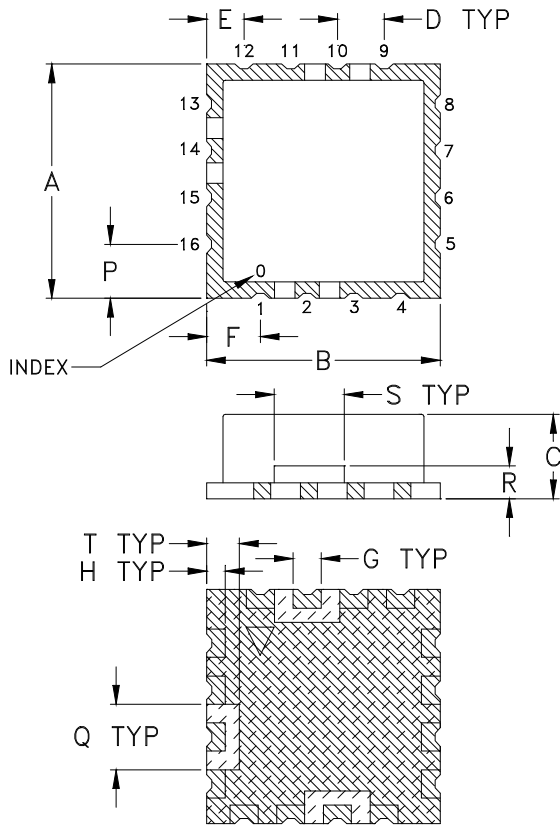

Suggested Layout,
Tolerance to be within $\pm .002$

| CASE # | A | B | C | D | E | F | G | H | J | K |
|--------|-----------------|-----------------|----------------|----------------|----------------|----------------|----------------|----------------|-----------------|----------------|
| CK605 | .500 (12.70) | .500 (12.70) | .180 (4.57) | .100 (2.54) | .080 (2.03) | .115 (2.92) | .060 (1.52) | .040 (1.02) | .540 (13.72) | .060 (1.52) |

| CASE # | L | M | N | P | Q | R | S | T | WT. GRAM |
|--------|----------------|----------------|----------------|----------------|----------------|----------------|----------------|----------------|---------------------|
| CK605 | .100 (2.54) | .135 (3.43) | .135 (3.43) | .115 (2.92) | .140 (3.56) | .070 (1.78) | .150 (3.81) | .070 (1.78) | 1.2 +0.5 -0.0 |

Dimensions are in inches (mm). Tolerances: 2 Pl. $\pm .03$; 3Pl. $\pm .015$

Notes:

- Case material: Nickel-Silver alloy.
- Base: Printed wiring laminate.
- Termination finish:
For RoHS Case Styles: 3-5 μ inch (.08-.13 microns) Gold over 120-240 μ inch (3.05-6.10 microns) Nickel plate.
All models, (+) suffix.



P.O. Box 350166, Brooklyn, New York 11235-0003 (718) 934-4500 Fax (718) 332-4661 For detailed performance specs & shopping online see Mini-Circuits web site



The Design Engineers Search Engine Provides ACTUAL Data Instantly From MINI-CIRCUITS At: www.minicircuits.com

RF/IF MICROWAVE COMPONENTS

Tape & Reel Packaging TR-F37

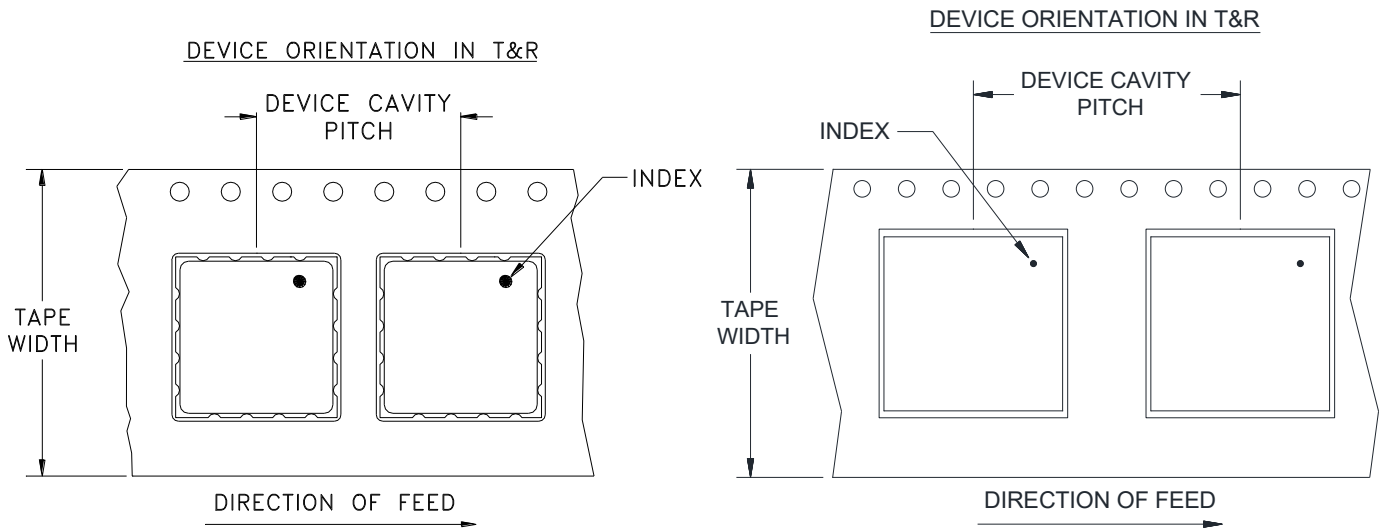

| Tape Width, mm | Device Cavity Pitch, mm | Reel Size, inches | Devices per Reel | |
|----------------|-------------------------|-------------------|-------------------------------------|-----|
| 24 | 16 | 7 | Small quantity standards (see note) | 10 |
| | | | | 20 |
| | | | | 50 |
| | | | | 100 |
| | | 13 | Standard | 200 |
| 500 | | | | |

Note: Please consult individual model data sheet to determine device per reel availability.

Mini-Circuits carrier tape materials provide protection from ESD (Electro-Static Discharge) during handling and transportation. Tapes are static dissipative and comply with industry standards EIA-481/EIA-541.

Go to: www.minicircuits.com/pages/pdfs/tape.pdf



INTERNET <http://www.minicircuits.com>

P.O. Box 350166, Brooklyn, New York 11235-0003 (718) 934-4500 Fax (718) 332-4661

Distribution Centers NORTH AMERICA 800-654-7949 • 417-335-5935 • Fax 417-335-5945 • EUROPE 44-1252-832600 • Fax 44-1252-837010

Mini-Circuits ISO 9001 & ISO 14001 Certified

THIRD ANGLE PROJECTION

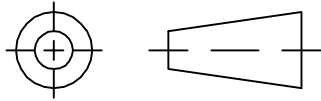

REVISIONS

| REV | ECN No. | DESCRIPTION | DATE | DR | AUTH |
|-----|---------|---------------------------|----------|-----|------|
| E | M105563 | ADDED "r1" PIN CONNECTION | 06/02/06 | MMG | DJ |
| F | M105640 | CORRECTED NOTE 2 | 06/08/06 | MMG | MM |
| G | M124395 | ADDED "RAMP" | 09/09 | EM | HH |
| G | R77589 | ADDED "RAMP" | 09/09 | EM | HH |

SUGGESTED MOUNTING CONFIGURATION FOR
CK605 CASE STYLE, "kg/rl/16AM01" PIN CONNECTION

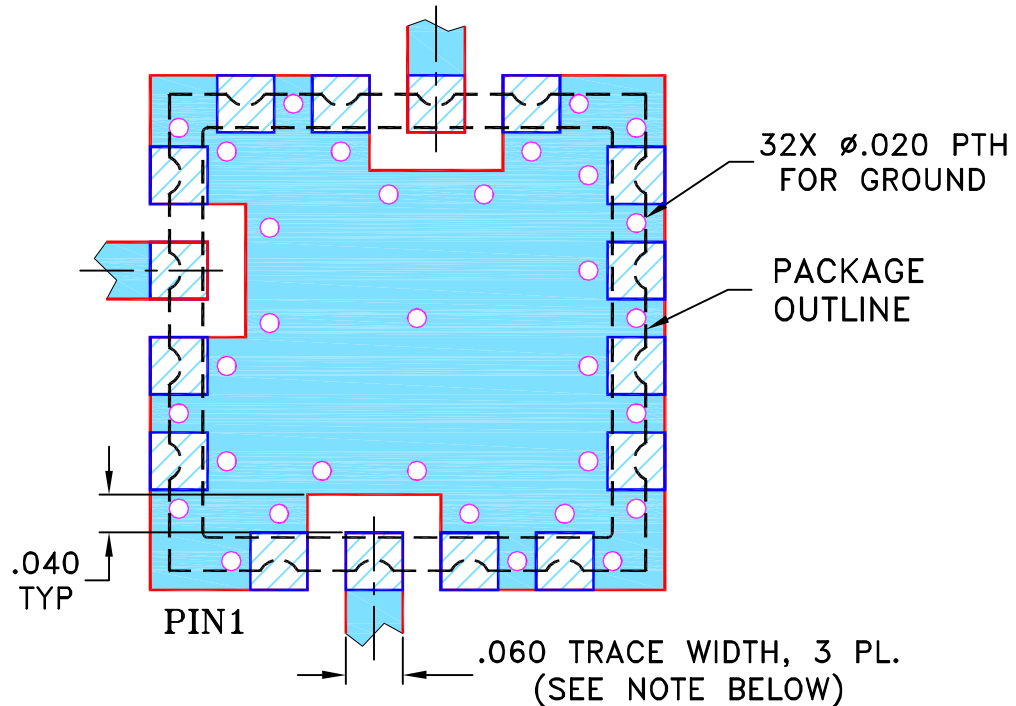

NOTES:

1. TRACE WIDTH IS SHOWN FOR FR4 WITH DIELECTRIC THICKNESS .030" ± .002"; COPPER: 1/2 OZ. EACH SIDE. FOR OTHER MATERIALS TRACE WIDTH MAY NEED TO BE MODIFIED.
2. BOTTOM SIDE OF THE BOTTOM IS CONTINUOUS GROUND PLANE.

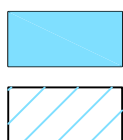

DENOTES PCB COPPER LAYOUT WITH SMOBC (SOLDER MASK OVER BARE COPPER)

DENOTES COPPER LAND PATTERN FREE OF SOLDER MASK

| UNLESS OTHERWISE SPECIFIED | INITIALS | DATE |
|----------------------------|-------------|----------|
| DIMENSIONS ARE IN INCHES | DRAWN AV | 08/07/00 |
| TOLERANCES ON: | CHECKED SK | 08/08/00 |
| 2 PL DECIMALS ± | APPROVED DB | 08/08/00 |
| 3 PL DECIMALS ± .005 | | |
| ANGLES ± | | |
| FRACTIONS ± | | |

 **Mini-Circuits®** 13 Neptune Avenue
Brooklyn NY 11235

PL,kg/rl/16AM01,CK605,ROS/LAVI/RAMP

| | | | |
|------------------|---------------------|--------------------------|-----------|
| SIZE A | CODE IDENT 15542 | DRAWING NO: 98-PL-012 | REV: G |
| FILE: 98PL012 | SCALE: 5:1 | SHEET: 1 OF 1 | |

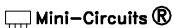
 Mini-Circuits®
THIS DOCUMENT AND ITS CONTENTS ARE THE PROPERTY OF MINI-CIRCUITS. EXCEPT FOR USE EXPRESSLY GRANTED, IN WRITING, TO ITS VENDORS, VENDEE AND THE UNITED STATES GOVERNMENT, MINI-CIRCUITS RESERVES ALL PROPRIETARY DESIGN, USE, MANUFACTURING AND REPRODUCTION RIGHTS THERETO. THESE CONTENTS SHALL NOT BE USED, DUPLICATED OR DISCLOSED TO ANY OUTSIDE PARTY, IN WHOLE OR IN PART, WITHOUT WRITTEN PERMISSION OF MINI-CIRCUITS.

ASHEETA1.DWG REV:A DATE:01/12/95

Evaluation Board and Circuit

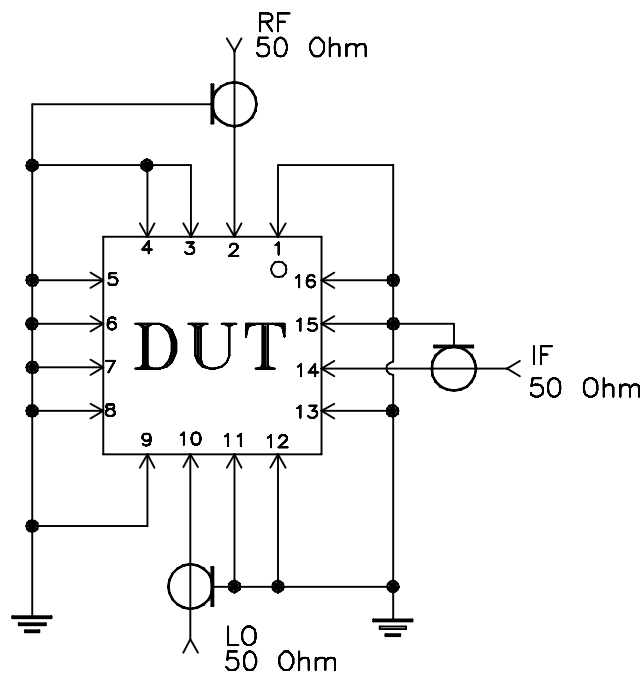
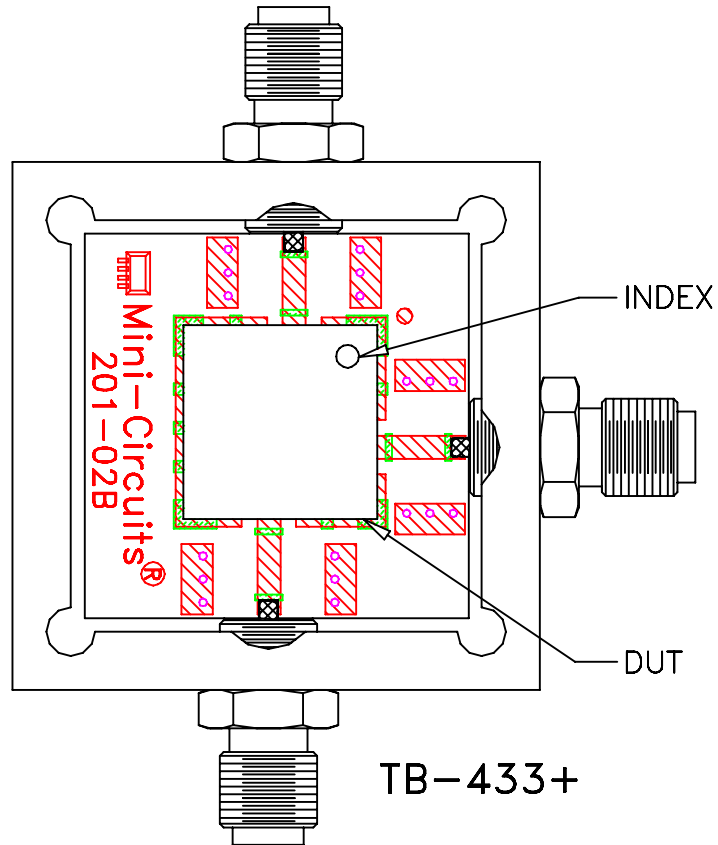

Notes:

1. SMA Female connectors.
2. PCB Material: Rogers R04350 or equivalent,
Dielectric Constant=3.5, Thickness=.028 inch.

Schematic Diagram

 **Mini-Circuits®**

All Mini-Circuits products are manufactured under exacting quality assurance and control standards, and are capable of meeting published specifications after being subjected to any or all of the following physical and environmental test.

| Specification | Test/Inspection Condition | Reference/Spec |
|--------------------------------|---|--|
| Operating Temperature | -45° to 85°C Ambient Environment | Individual Model Data Sheet |
| Storage Temperature | -55° to 100° C Ambient Environment | Individual Model Data Sheet |
| Humidity | 90 to 95% RH, 240 hours, 50°C | MIL-STD-202, Method 103, Condition A, Except 50°C and end-point electrical test done within 12 hours |
| Thermal Shock | -55° to 100°C, 100 cycles | MIL-STD-202, Method 107, Condition A-3, except +100°C |
| Solder Reflow Heat | Sn-Pb Eutectic Process: 225°C peak Pb-Free Process, 245°C peak | J-STD-020, Table 4-1, 4-2 and 5-2, Figure 5-1 |
| Solderability | 10X Magnification | J-STD-002, 95% Coverage |
| Vibration (High Frequency) | 20g peak, 10-2000 Hz, 12 times in each of three perpendicular directions (total 36) | MIL-STD-202, Method 204, Condition D |
| Mechanical Shock | 50g, 11 ms, 1/2-sine, 18 shocks: 3 each direction, each of 3 axes | MIL-STD-202, Method 213, Condition A |
| Marking Resistance to Solvents | Isopropyl alcohol + mineral spirits at 25°C; terpene defluxer at 25°C; distilled water + proylene glycol monomethyl ether + monoethanolamine at 63°C to 70°C | MIL-STD-202, Method 215 |