



MMIC SURFACE MOUNT

Monolithic Amplifier

LEE1-6+

50Ω DC to 6000 MHz

THE BIG DEAL

- High Gain, Typ. 12.9 dB
- High OIP3, Typ. +32 dBm
- High P1dB, Typ. +17.3 dBm
- Low Operating Current, 70 mA at +5 V
- 1.5x1.5 mm 6-Lead QFN-Style Package

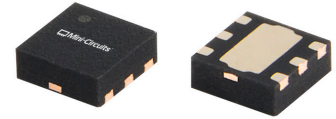

Generic photo used for illustration purposes only

APPLICATIONS

- Satellite Communications
- 5G MIMO and Backhaul MW Radio Systems
- Radar, EW and ECM Defense Systems
- ISM Band Applications

FUNCTIONAL DIAGRAM (TOP VIEW)

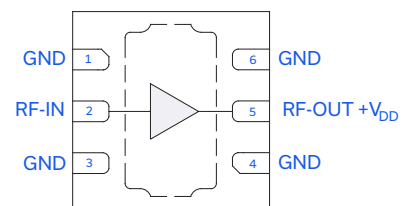

PRODUCT OVERVIEW

The LEE1-6+ is high-linearity gain block amplifier in a low-cost surface mount package, fabricated using an InGaP/GaAs HBT semiconductor process. Operating from DC to 6000 MHz, this amplifier features high dynamic range with typical 4.3 dB noise figure, 12.9 dB gain, +17.3 dBm P1dB, and +32 dBm OIP3 at 2 GHz. This combination of performance makes it ideal for sensitive, high dynamic range receiver applications. The LEE1-6+ is a current driven device consuming only 70mA from a +5 V supply, is well matched to 50Ω, and comes in a small, low-profile 1.5x1.5 mm QFN-style package for ease of integration into dense circuit board layouts.

KEY FEATURES

Features	Advantages
Low Power Consumption, Typ. 70 mA at +5 V	At only 70 mA, this amplifier is ideal for applications with limited available power or densely packed applications where thermal and power management is critical.
High Dynamic Range <ul style="list-style-type: none"> • OIP3, Typ. +32 dBm at 2 GHz • P1dB, Typ. +17.3 dBm at 2 GHz 	The LEE1-6+ matches industry leading OIP3 performance relative to device size and power consumption. The combination of high linearity and output power make this gain block amplifier ideal for use as a second stage in ultra-high dynamic range receivers.
1.5x1.5 mm 6-Lead QFN-Style Package	Very small footprint saves space in dense PCB layouts while providing low inductance, repeatable transitions, and excellent thermal contact with the PCB. Industry standard packaging allows for ease of assembly in high volume manufacturing processes.
No External Matching Components Required	The LEE1-6+ features excellent input and output return loss of 15-30 dB up to 4 GHz, eliminating the need for any external matching components while demonstrating excellent reliability.





MMIC SURFACE MOUNT

Monolithic Amplifier

LEE1-6+

Mini-Circuits

50Ω DC to 6000 MHz

ELECTRICAL SPECIFICATIONS¹ AT +25°C, I_{DD} = 70 mA, UNLESS NOTED OTHERWISE

Parameter	Frequency (MHz)	Min.	Typ.	Max.	Units
Frequency Range		DC ⁶		6000	MHz
Gain	10	11.5	13.2		dB
	1000	12.1	13.0		
	2000	11.9	12.9		
	3000	11.6	12.7		
	4000	11.1	12.4		
	6000	10.1	11.3		
Input Return Loss	10		23		dB
	1000		22		
	2000		20		
	3000		18		
	4000		15		
	6000		11		
Output Return Loss	10		40		dB
	1000		36		
	2000		30		
	3000		25		
	4000		22		
	6000		17		
Isolation	10 - 6000		19		dB
Output Power at 1 dB Compression (P1dB)	10		+17.5		dBm
	1000		+17.8		
	2000		+17.3		
	3000		+16.4		
	4000		+14.8		
	6000		+11.3		
Output Power at 3 dB Compression (P3dB)	10		+18.3		dBm
	1000		+18.4		
	2000		+18.0		
	3000		+17.1		
	4000		+15.9		
	6000		+13.0		
Output Third-Order Intercept Point (P _{OUT} = 0 dBm/Tone)	10		+28.8		dBm
	1000		+35.6		
	2000		+32.0		
	3000		+29.2		
	4000		+26.6		
	6000		+22.9		
Noise Figure	10		4.2		dB
	1000		4.2		
	2000		4.3		
	3000		4.4		
	4000		4.5		
	6000		4.8		
Device Operating Voltage (V _{DD}) ²		+4.7	+5	+5.3	V
Device Operating Current (I _{DD}) ³			70		mA
Device Voltage Variation vs. Temperature ⁴			-3.143		mV/°C
Device Voltage Variation vs. Current ⁵			12.857		mV/mA

1. Tested on Mini-Circuits Characterization Test Board MB-225-6C+. See Figure 2. Board loss de-embedded to the device.
2. Operating voltage applied to device LEE1-6+.
3. Current at P_N = -25 dBm.
4. (Voltage at +85°C - Voltage at -55°C) / (+85°C - -55°C)
5. (Voltage at 84 mA - Voltage at 56 mA) / (84 mA - 56 mA)
6. Low frequency cut off determined by external coupling capacitor.





TYPICAL PERFORMANCE GRAPHS

Note: The following data was taken on the Mini-Circuits Characterization Test Board MB-225-6C+ (Figure 2).

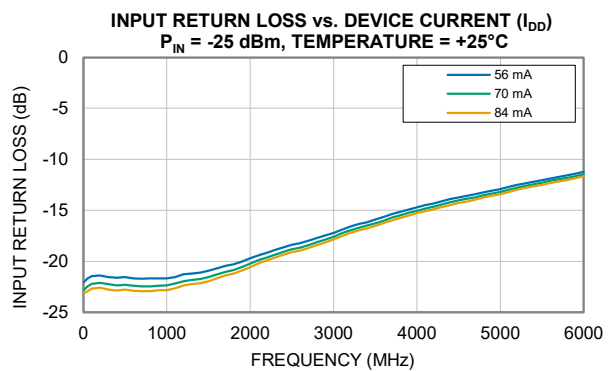
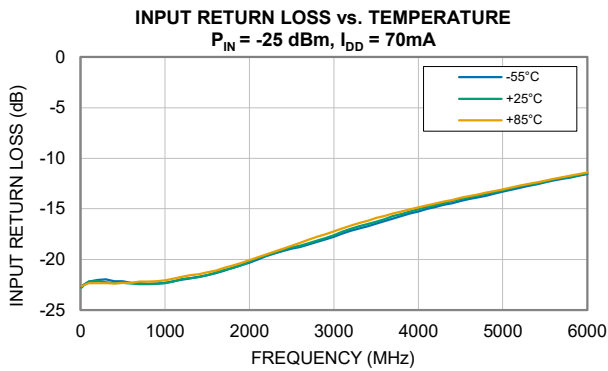
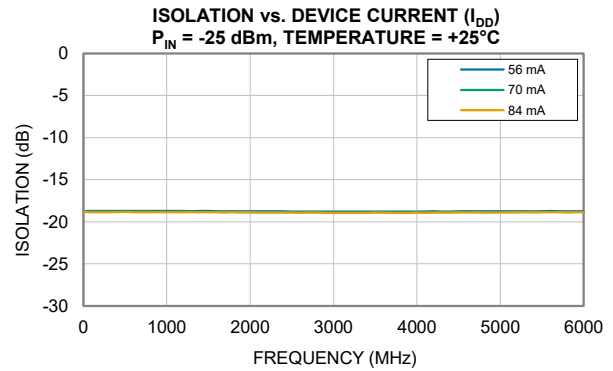
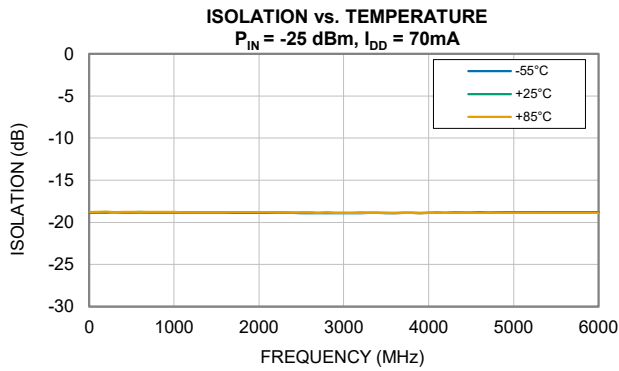
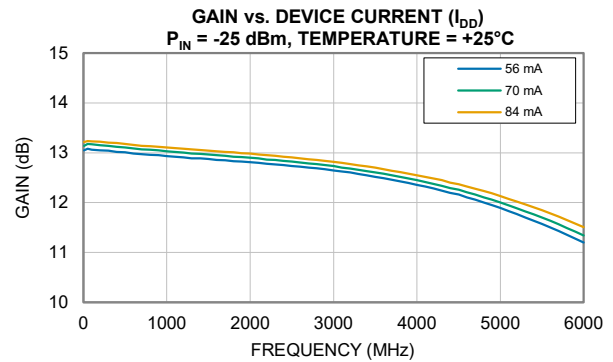
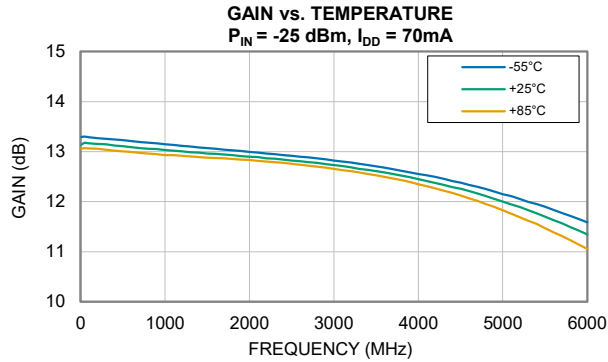



TYPICAL PERFORMANCE GRAPHS

Note: The following data was taken on the Mini-Circuits Characterization Test Board MB-225-6C+ (Figure 2).

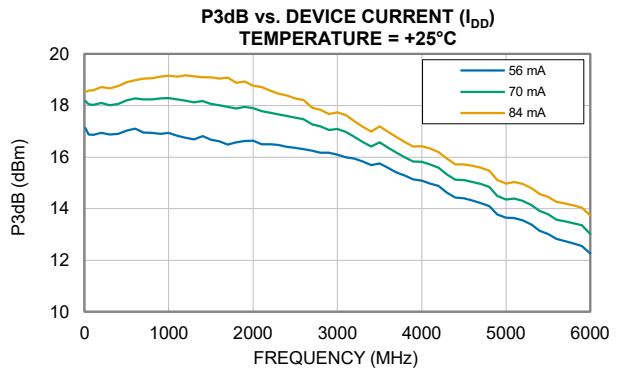
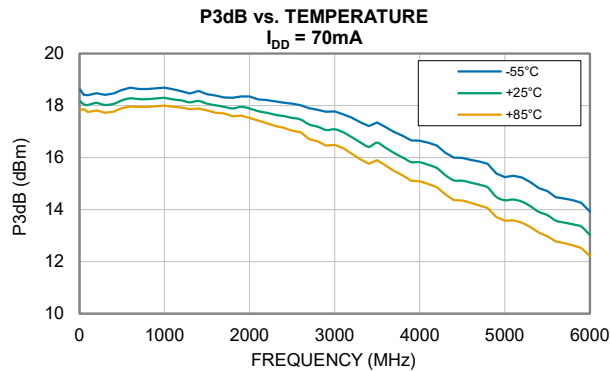
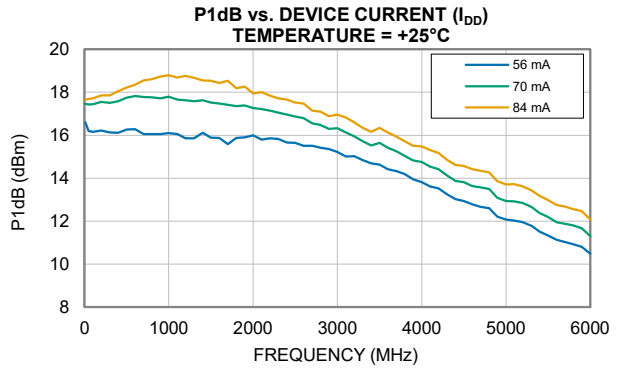
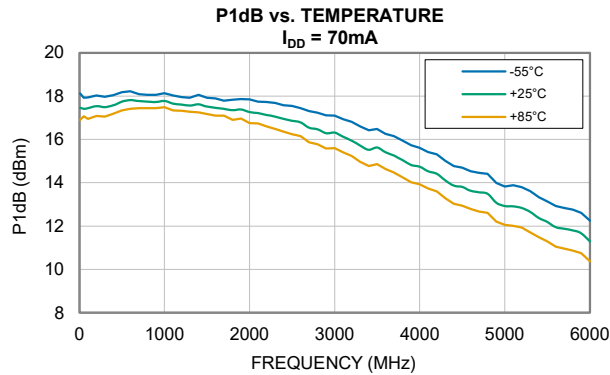
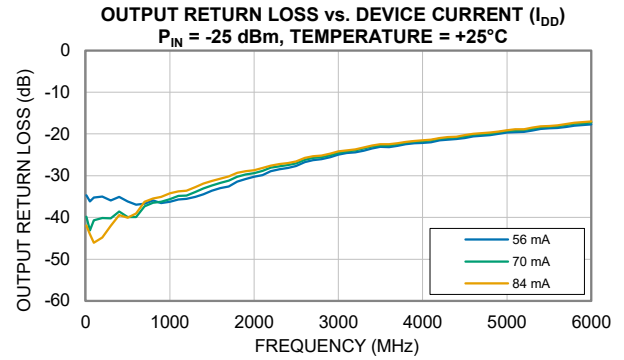
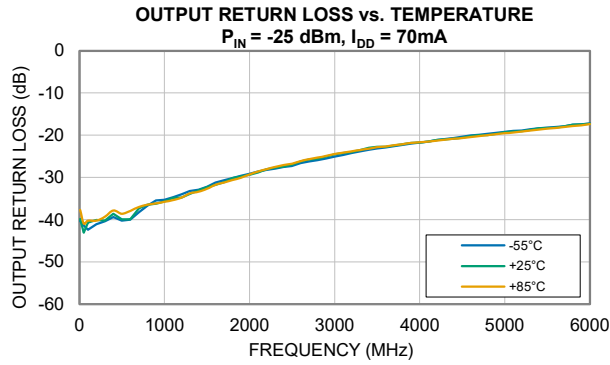



TYPICAL PERFORMANCE GRAPHS

Note: The following data was taken on the Mini-Circuits Characterization Test Board MB-225-6C+ (Figure 2).

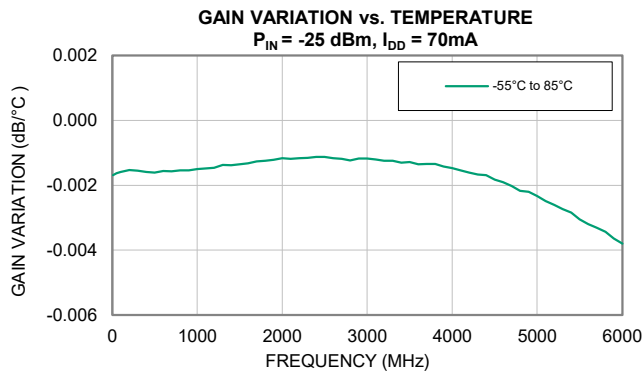
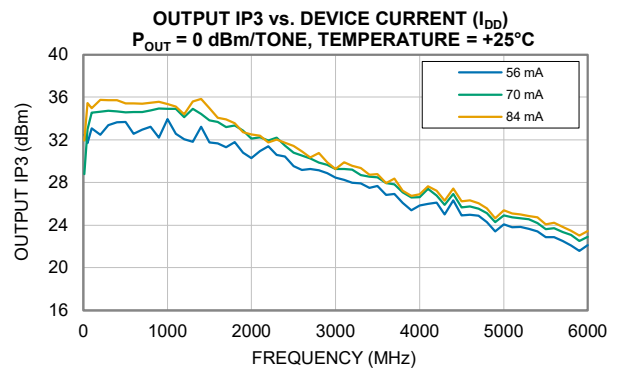
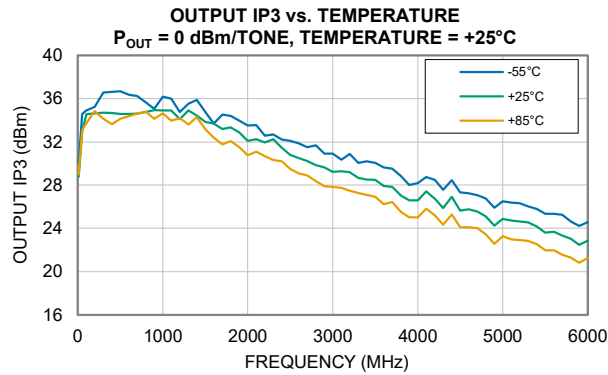
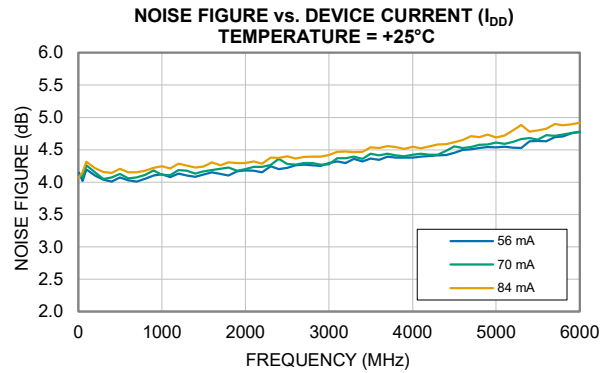
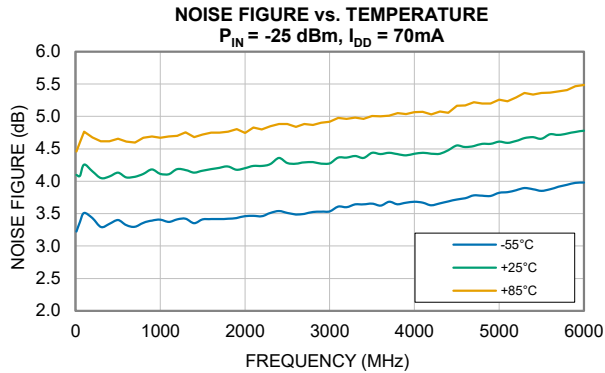



MMIC SURFACE MOUNT

Monolithic Amplifier

LEE1-6+

Mini-Circuits

50Ω DC to 6000 MHz

ABSOLUTE MAXIMUM RATINGS⁷

Parameter	Ratings
Operating Temperature	-55°C to +85°C
Storage Temperature	-65°C to +150°C
Junction Temperature ⁸	+150°C
Total Power Dissipation	0.68 W
Input Power (CW), I _{DD} = 70mA	+20 dBm
DC Voltage at V _{DD}	+5.5 V
DC Current I _{DD}	90 mA

7. Permanent damage may occur if any of these limits are exceeded. Maximum ratings are not intended for continuous normal operation.

8. Peak temperature on top of Die.

THERMAL RESISTANCE

Parameter	Ratings
Thermal Resistance (Θ_{JC}) ⁹	95.1°C/W

9. Θ_{JC} = (Hot Spot Temperature on Die - Temperature at Ground Lead)/Dissipated Power

ESD RATING

	Class	Voltage Range	Reference Standard
HBM	1B	500 V to < 1000 V	ANSI/ESDA/JEDEC JS-001-2023
CDM	C3	> 1000 V	ANSI/ESDA/JEDEC JS-002-2022



ESD HANDLING PRECAUTION: This device is designed to be Class 1B for HBM. Static charges may easily produce potentials higher than this with improper handling and can discharge into DUT and damage it. As a preventive measure Industry standard ESD handling precautions should be used at all times to protect the device from ESD damage.

MSL RATING

Moisture Sensitivity: MSL1 in accordance with IPC/JEDEC J-STD-020E/JEDEC J-STD-033C



FUNCTIONAL DIAGRAM (TOP VIEW)

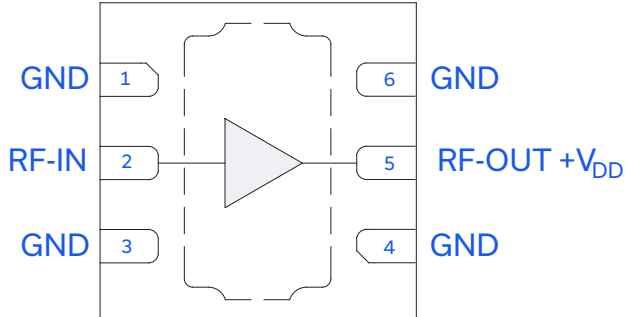

Figure 1. LEE1-6+ Functional Diagram

PAD DESCRIPTION

Function	Pad Number	Application Description (Refer to Fig 2)
RF-IN	2	RF-IN Pad connects to RF Input port.
RF-OUT+V _{DD}	5	RF-OUT Pad connects to RF Output port. V _{DD} is applied via external bias tee.
GND	1, 3, 4, 6 & Paddle	Connects to ground.

CHARACTERIZATION TEST BOARD

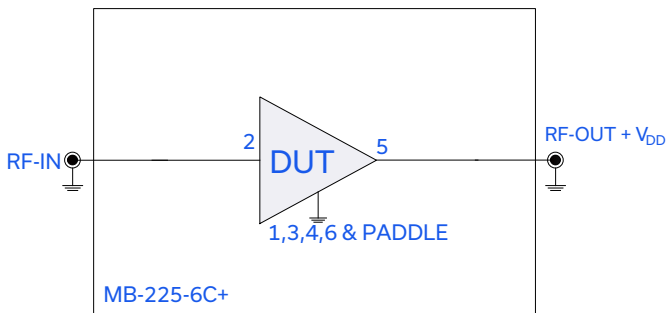

Figure 2. LEE1-6+ Characterization Circuit

Electrical Parameters and Conditions

Gain, Return Loss, Output Power at 1dB Compression (P1dB), Output IP3 (OIP3), and Noise Figure measured using N5242A PNA-X microwave network analyzer.

Conditions:

1. Gain and Return Loss: P_{IN} = -25 dBm
2. Output IP3 (OIP3): Two tones, spaced 1 MHz apart, 0 dBm/Tone at output.
3. I_{DD} = 70mA at V_{DD} = +5 V Typ.



EVALUATION BOARD

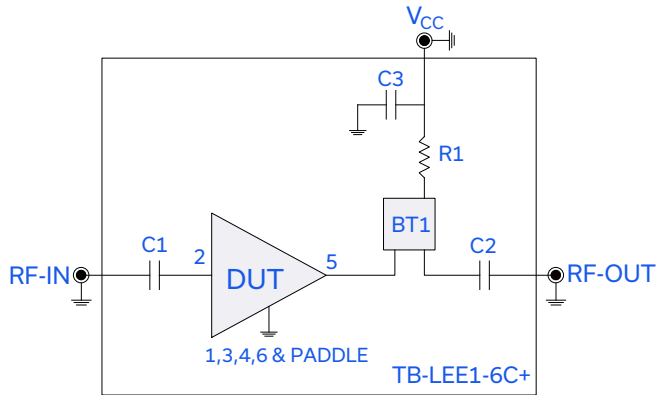

Figure 3. LEE1-6+ Evaluation Circuit

Electrical Parameters and Conditions

Gain, Return Loss, Output Power at 1dB Compression (P1dB), Output IP3 (OIP3), and Noise Figure measured using N5242A PNA-X microwave network analyzer.

Conditions:

1. Gain and Return Loss: $P_{IN} = -25$ dBm
2. Output IP3 (OIP3): Two tones, spaced 1 MHz apart, 0 dBm/Tone at output.
3. $V_{CC} = +8$ V

Component	Value	Size	Part Number	Manufacturer
C1, C2	2.4 nF	0402	GRM1557U1A242JA1D	Murata
C3	0.1 μ F	0805	GCM21BR91H104KA37L	Murata
R1	43 Ω , 0.5W	1210	RC1210FR-0743RL	Yageo
BT1	-	3.8x3.8 mm	TCBT-14+	Mini-Circuits



TYPICAL PERFORMANCE GRAPHS

Note: The following data was taken on the Mini-Circuits Evaluation Board TB-LEE1-6C+ (Figure 3).

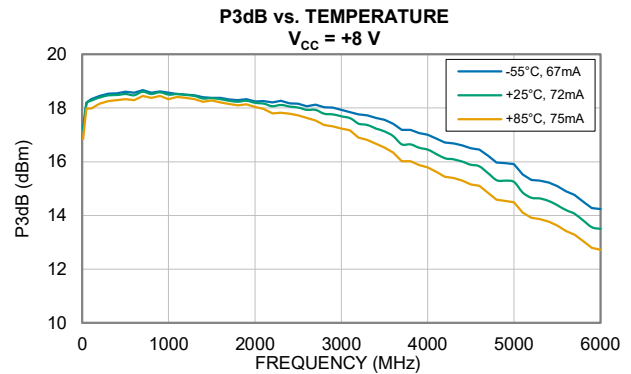
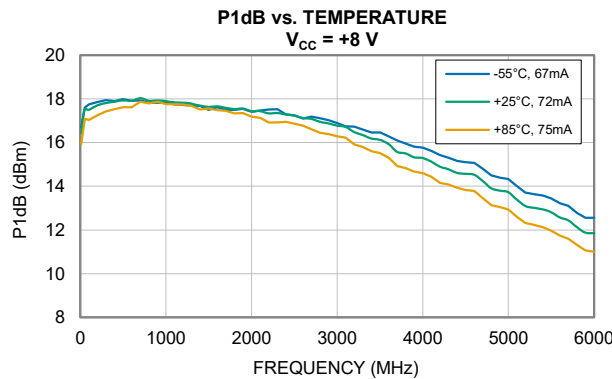
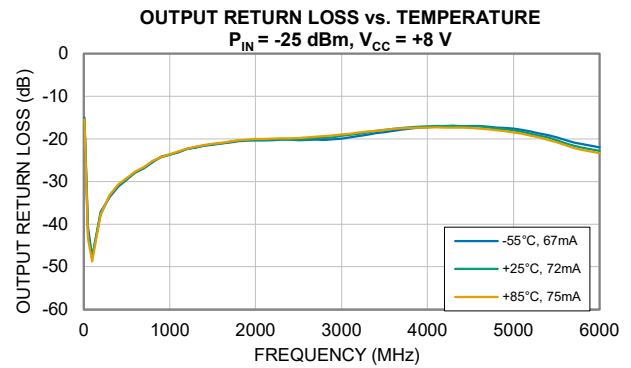
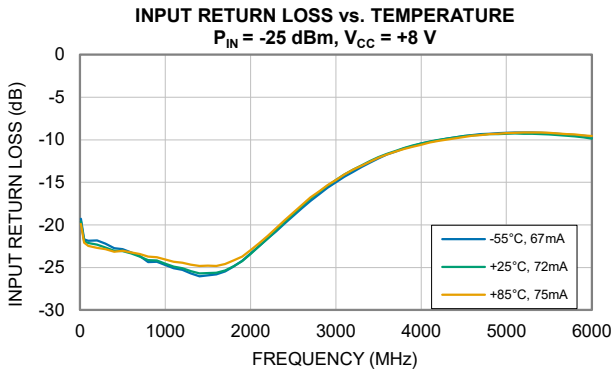
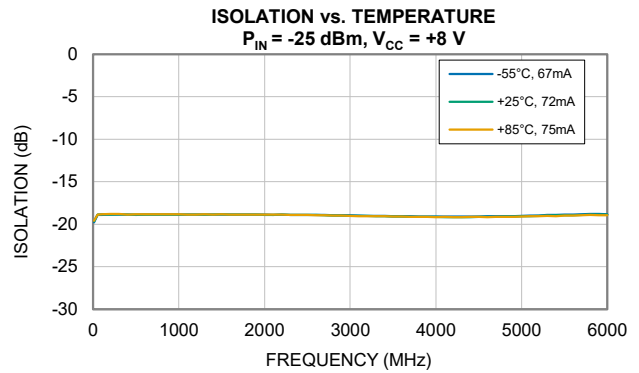
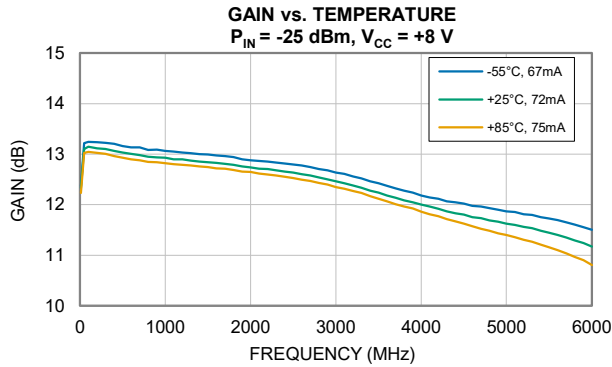



TYPICAL PERFORMANCE GRAPHS

Note: The following data was taken on the Mini-Circuits Evaluation Board TB-LEE1-6C+ (Figure 3).

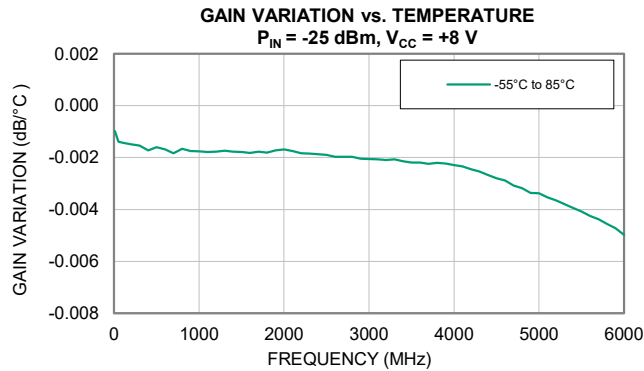
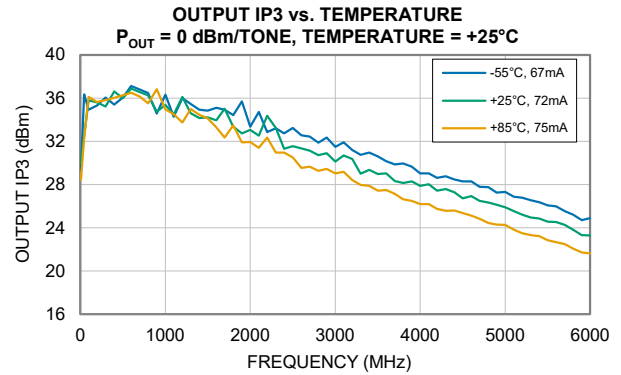
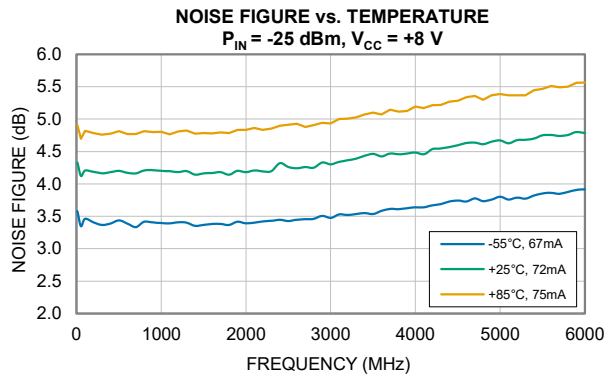



CASE STYLE DRAWING

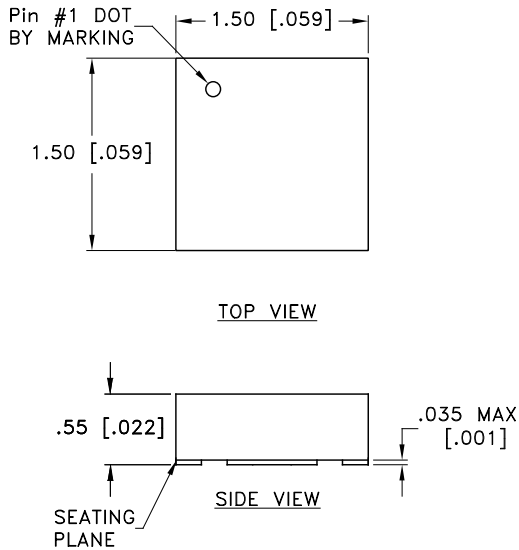

PCB Land Pattern

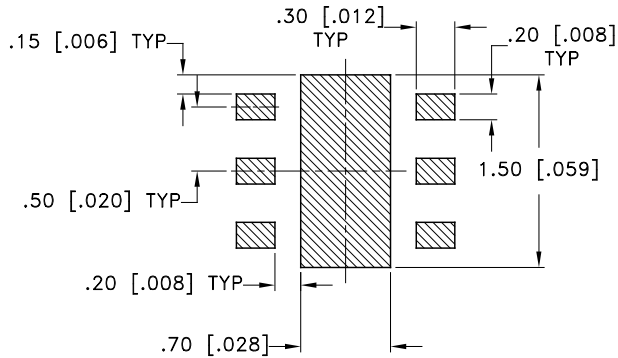

Suggested Layout,
Tolerance to be within ±0.050 mm

NOTES:

1. DENOTES METALLIZATION

Weight: 0.0036 grams

Dimensions are in mm [inches]. Tolerances: 2Pl. ±0.05 mm [0.002 inches].

PRODUCT MARKING

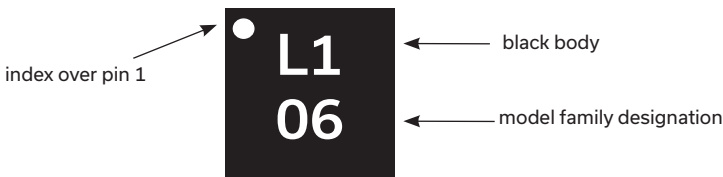

Marking may contain other features or characters for internal lot control



MMIC SURFACE MOUNT

Monolithic Amplifier

LEE1-6+

50Ω DC to 6000 MHz

Mini-Circuits

ADDITIONAL DETAILED INFORMATION IS AVAILABLE ON OUR DASHBOARD

[CLICK HERE](#)

Performance Data & Graphs	Data Graphs S-Parameter (S2P Files) Data Set (.zip file)
Case Style	KC3011 Plastic package, exposed paddle, Lead Finish: Nickel Palladium Gold
RoHS Status	Compliant
Tape & Reel Standard quantities available on reel	F66 7" reels with 20, 50, 100, 200, 500, 1000, 2000, or 3000 devices
Suggested Layout for PCB Design	PL-851
Evaluation Board	TB-LEE1-6C+ Gerber File
Environmental Ratings	ENV08T1

NOTES

- A. Performance and quality attributes and conditions not expressly stated in this specification document are intended to be excluded and do not form a part of this specification document.
- B. Electrical specifications and performance data contained in this specification document are based on Mini-Circuit's applicable established test performance criteria and measurement instructions.
- C. The parts covered by this specification document are subject to Mini-Circuits standard limited warranty and terms and conditions (collectively, "Standard Terms"); Purchasers of this part are entitled to the rights and benefits contained therein. For a full statement of the standard terms and the exclusive rights and remedies thereunder, please visit Mini-Circuits' website at www.minicircuits.com/terms/viewterm.html



Typical Performance Data

Note: The following data was taken on the Mini-Circuits Characterization Test Board MB-225-6C+ (Figure 2).

Definitions:

Input Return Loss = S11 (dB)

Gain = S21 (dB)

Isolation = S12 (dB)

Output Return Loss = S22 (dB)

TEST CONDITIONS: $V_{DD} = +4.76V$, $I_{DD} = 56mA$ @ Temperature = $+25^{\circ}C$

FREQ	Gain	Isolation	Input Return Loss	Output Return Loss	Stability		1dB Comp. Output	3dB Comp. Output	Noise Figure	IP-3 Output
					K	Measure				
(MHz)	(dB)	(dB)	(dB)	(dB)			(dBm)	(dBm)	(dB)	(dBm)
10.00	13.04	18.8	22.0	34.7	1.2	0.7	16.6	17.1	4.1	32.5
50.00	13.08	18.7	21.7	36.2	1.2	0.7	16.2	16.9	4.0	31.7
100.0	13.06	18.7	21.5	35.2	1.2	0.7	16.2	16.9	4.2	33.1
200.0	13.05	18.7	21.4	35.0	1.2	0.7	16.2	16.9	4.1	32.5
300.0	13.04	18.7	21.5	35.9	1.2	0.7	16.1	16.9	4.0	33.4
400.0	13.02	18.7	21.6	35.0	1.2	0.7	16.1	16.9	4.0	33.6
500.0	13.01	18.7	21.6	36.2	1.2	0.7	16.3	17.0	4.1	33.7
600.0	12.99	18.7	21.7	37.0	1.2	0.7	16.3	17.1	4.0	32.6
700.0	12.97	18.7	21.7	36.7	1.2	0.7	16.0	17.0	4.0	33.0
800.0	12.96	18.7	21.7	35.9	1.2	0.7	16.0	16.9	4.1	33.2
900.0	12.95	18.7	21.7	36.5	1.2	0.7	16.0	16.9	4.1	32.2
1000.0	12.93	18.7	21.7	36.3	1.2	0.7	16.1	16.9	4.1	34.0
1100.0	12.92	18.7	21.5	35.7	1.2	0.7	16.0	16.8	4.1	32.6
1200.0	12.91	18.7	21.3	35.6	1.2	0.8	15.9	16.7	4.1	32.0
1300.0	12.89	18.7	21.2	35.0	1.2	0.8	15.9	16.7	4.1	31.8
1400.0	12.89	18.7	21.1	34.5	1.2	0.8	16.1	16.8	4.1	33.2
1500.0	12.87	18.7	20.9	33.6	1.2	0.8	15.9	16.7	4.1	31.7
1600.0	12.86	18.7	20.7	32.9	1.2	0.8	15.9	16.6	4.2	31.7
1700.0	12.85	18.7	20.5	32.5	1.2	0.8	15.6	16.5	4.1	31.3
1800.0	12.83	18.7	20.3	31.4	1.2	0.8	15.9	16.6	4.1	31.8
1900.0	12.82	18.7	20.0	30.8	1.2	0.8	15.9	16.6	4.2	30.8
2000.0	12.81	18.8	19.7	30.3	1.2	0.8	16.0	16.6	4.2	30.3
2100.0	12.80	18.8	19.4	29.8	1.2	0.8	15.8	16.5	4.2	31.0
2200.0	12.78	18.7	19.2	28.9	1.2	0.8	15.8	16.5	4.1	31.4
2300.0	12.77	18.8	18.9	28.4	1.2	0.8	15.8	16.5	4.2	30.6
2400.0	12.75	18.8	18.6	28.2	1.2	0.8	15.7	16.4	4.2	30.4
2500.0	12.74	18.8	18.4	27.7	1.2	0.8	15.6	16.4	4.2	29.5
2600.0	12.72	18.8	18.2	26.7	1.2	0.8	15.5	16.3	4.3	29.2
2700.0	12.70	18.8	18.0	26.3	1.2	0.8	15.5	16.2	4.3	29.3
2800.0	12.69	18.8	17.7	26.0	1.2	0.8	15.4	16.2	4.3	29.2
2900.0	12.67	18.8	17.5	25.6	1.2	0.8	15.3	16.2	4.3	28.9
3000.0	12.65	18.8	17.2	25.0	1.2	0.8	15.2	16.1	4.3	28.5
3100.0	12.62	18.8	16.9	24.6	1.2	0.8	15.0	16.0	4.3	28.2
3200.0	12.60	18.8	16.6	24.4	1.2	0.8	15.0	15.9	4.3	28.0
3300.0	12.57	18.8	16.3	24.0	1.2	0.8	14.8	15.8	4.4	27.9
3400.0	12.55	18.8	16.2	23.4	1.2	0.8	14.7	15.7	4.3	27.5
3500.0	12.52	18.8	15.9	23.1	1.2	0.8	14.6	15.7	4.4	27.7
3600.0	12.49	18.8	15.6	23.1	1.2	0.8	14.4	15.6	4.3	26.8
3700.0	12.46	18.8	15.4	22.9	1.2	0.8	14.3	15.4	4.4	26.9
3800.0	12.43	18.8	15.2	22.5	1.2	0.8	14.2	15.3	4.4	26.1
3900.0	12.40	18.8	14.9	22.2	1.2	0.8	14.0	15.1	4.4	25.4
4000.0	12.36	18.8	14.7	22.2	1.3	0.8	13.8	15.1	4.4	25.8
4100.0	12.32	18.8	14.5	21.9	1.3	0.8	13.6	15.0	4.4	26.0
4200.0	12.28	18.8	14.3	21.5	1.3	0.8	13.5	14.9	4.4	26.1
4300.0	12.24	18.8	14.1	21.3	1.3	0.8	13.2	14.6	4.4	25.0
4400.0	12.20	18.8	13.9	21.2	1.3	0.8	13.0	14.4	4.4	26.3
4500.0	12.16	18.8	13.7	20.9	1.3	0.8	12.9	14.4	4.5	24.9
4600.0	12.11	18.7	13.6	20.6	1.3	0.8	12.8	14.3	4.5	25.0
4700.0	12.06	18.8	13.4	20.4	1.3	0.9	12.7	14.2	4.5	24.9
4800.0	12.00	18.7	13.2	20.3	1.3	0.9	12.6	14.1	4.5	24.3
4900.0	11.95	18.8	13.1	20.0	1.3	0.9	12.2	13.8	4.5	23.4
5000.0	11.89	18.7	12.9	19.7	1.3	0.9	12.1	13.6	4.5	24.1
5100.0	11.83	18.7	12.7	19.5	1.3	0.9	12.0	13.6	4.5	23.8
5200.0	11.77	18.7	12.5	19.5	1.3	0.9	12.0	13.5	4.5	23.8
5300.0	11.71	18.7	12.3	19.1	1.3	0.9	11.8	13.4	4.5	23.7
5400.0	11.64	18.8	12.2	18.8	1.3	0.9	11.5	13.1	4.6	23.4
5500.0	11.57	18.7	12.0	18.7	1.3	0.9	11.3	13.0	4.6	22.9
5600.0	11.50	18.7	11.9	18.6	1.3	0.9	11.1	12.8	4.6	22.9
5700.0	11.43	18.7	11.7	18.3	1.3	0.9	11.0	12.7	4.7	22.5
5800.0	11.35	18.7	11.6	18.0	1.3	0.9	10.9	12.6	4.7	22.1
5900.0	11.28	18.7	11.4	17.9	1.3	0.9	10.8	12.5	4.8	21.6
6000.0	11.20	18.7	11.2	17.7	1.3	0.9	10.5	12.3	4.8	22.1

Typical Performance Data

Note: The following data was taken on the Mini-Circuits Characterization Test Board MB-225-6C+ (Figure 2).

Definitions:

Input Return Loss = S11 (dB)

Gain = S21 (dB)

Isolation = S12 (dB)

Output Return Loss = S22 (dB)

TEST CONDITIONS: $V_{DD} = +5V$, $I_{DD} = 70.0mA$ @ Temperature = $+25^{\circ}C$

FREQ	Gain	Isolation	Input Return Loss	Output Return Loss	Stability		1dB Comp. Output	3dB Comp. Output	Noise Figure	IP-3 Output
					K	Measure				
(MHz)	(dB)	(dB)	(dB)	(dB)			(dBm)	(dBm)	(dB)	(dBm)
10.00	13.14	18.8	22.8	39.8	1.2	0.7	17.5	18.2	4.1	28.8
50.00	13.18	18.8	22.5	43.1	1.2	0.7	17.4	18.0	4.1	33.0
100.0	13.17	18.8	22.2	40.7	1.2	0.7	17.4	18.0	4.3	34.5
200.0	13.15	18.8	22.1	40.1	1.2	0.7	17.5	18.1	4.2	34.6
300.0	13.14	18.8	22.2	40.2	1.2	0.7	17.5	18.0	4.0	34.7
400.0	13.12	18.8	22.4	38.6	1.2	0.7	17.6	18.1	4.1	34.7
500.0	13.10	18.8	22.3	39.9	1.2	0.7	17.7	18.2	4.1	34.6
600.0	13.09	18.8	22.4	39.9	1.2	0.7	17.8	18.3	4.1	34.6
700.0	13.07	18.8	22.4	37.3	1.2	0.7	17.8	18.2	4.1	34.6
800.0	13.06	18.8	22.5	36.5	1.2	0.7	17.8	18.2	4.1	34.8
900.0	13.05	18.8	22.4	36.2	1.2	0.7	17.7	18.3	4.2	34.9
1000.0	13.03	18.8	22.4	35.7	1.2	0.7	17.8	18.3	4.1	34.9
1100.0	13.02	18.8	22.2	34.9	1.2	0.7	17.7	18.2	4.1	34.9
1200.0	13.00	18.8	22.0	34.7	1.2	0.7	17.6	18.2	4.2	34.1
1300.0	12.99	18.8	21.8	33.9	1.2	0.8	17.6	18.1	4.2	34.9
1400.0	12.98	18.8	21.8	33.1	1.2	0.8	17.6	18.2	4.1	34.4
1500.0	12.97	18.8	21.6	32.3	1.2	0.8	17.5	18.1	4.2	33.8
1600.0	12.95	18.8	21.3	31.7	1.2	0.8	17.5	18.0	4.2	33.7
1700.0	12.94	18.8	21.1	31.1	1.2	0.8	17.4	18.0	4.2	33.2
1800.0	12.92	18.8	20.9	30.2	1.2	0.8	17.3	17.9	4.2	33.3
1900.0	12.91	18.8	20.6	29.7	1.2	0.8	17.4	17.9	4.2	32.9
2000.0	12.90	18.8	20.2	29.4	1.2	0.8	17.3	17.9	4.2	32.1
2100.0	12.89	18.8	19.9	28.8	1.2	0.8	17.2	17.8	4.2	32.3
2200.0	12.86	18.8	19.6	28.1	1.2	0.8	17.1	17.7	4.2	32.0
2300.0	12.85	18.9	19.3	27.7	1.2	0.8	17.1	17.6	4.3	32.2
2400.0	12.84	18.9	19.1	27.5	1.2	0.8	16.9	17.6	4.4	31.4
2500.0	12.82	18.8	18.8	27.0	1.2	0.8	16.9	17.5	4.3	30.8
2600.0	12.80	18.8	18.7	26.2	1.2	0.8	16.8	17.5	4.3	30.5
2700.0	12.79	18.9	18.4	25.7	1.2	0.8	16.5	17.3	4.3	30.2
2800.0	12.78	18.9	18.1	25.5	1.2	0.8	16.5	17.2	4.3	29.9
2900.0	12.75	18.9	17.9	25.1	1.2	0.8	16.3	17.1	4.3	29.7
3000.0	12.73	18.9	17.6	24.5	1.2	0.8	16.3	17.1	4.3	29.2
3100.0	12.71	18.9	17.3	24.2	1.2	0.8	16.1	17.0	4.4	29.3
3200.0	12.69	18.9	17.0	24.0	1.2	0.8	16.0	16.8	4.4	29.2
3300.0	12.66	18.9	16.7	23.5	1.2	0.8	15.7	16.6	4.4	28.7
3400.0	12.63	18.9	16.5	23.0	1.2	0.8	15.5	16.4	4.4	28.5
3500.0	12.61	18.9	16.3	22.7	1.2	0.8	15.6	16.6	4.4	28.5
3600.0	12.58	18.9	16.0	22.7	1.3	0.8	15.4	16.4	4.4	27.9
3700.0	12.55	18.9	15.7	22.5	1.3	0.8	15.3	16.2	4.4	27.8
3800.0	12.51	18.9	15.5	22.1	1.3	0.8	15.0	16.0	4.4	27.1
3900.0	12.48	18.9	15.3	21.8	1.3	0.8	14.8	15.8	4.4	26.6
4000.0	12.45	18.9	15.0	21.8	1.3	0.8	14.7	15.8	4.4	26.6
4100.0	12.41	18.9	14.8	21.5	1.3	0.8	14.5	15.7	4.4	27.4
4200.0	12.38	18.9	14.7	21.1	1.3	0.8	14.4	15.6	4.4	26.8
4300.0	12.34	18.9	14.4	20.9	1.3	0.8	14.1	15.3	4.4	25.9
4400.0	12.29	18.9	14.2	20.8	1.3	0.8	13.9	15.1	4.5	26.9
4500.0	12.26	18.8	14.0	20.6	1.3	0.8	13.8	15.1	4.6	25.7
4600.0	12.21	18.8	13.9	20.2	1.3	0.8	13.6	15.0	4.5	25.8
4700.0	12.16	18.8	13.7	20.0	1.3	0.8	13.6	15.0	4.5	25.5
4800.0	12.11	18.8	13.5	19.9	1.3	0.9	13.5	14.8	4.6	25.1
4900.0	12.06	18.8	13.3	19.6	1.3	0.9	13.1	14.5	4.6	24.3
5000.0	12.00	18.8	13.2	19.3	1.3	0.9	12.9	14.4	4.6	24.9
5100.0	11.94	18.8	13.0	19.1	1.3	0.9	12.9	14.4	4.6	24.7
5200.0	11.89	18.8	12.8	19.1	1.3	0.9	12.8	14.3	4.6	24.6
5300.0	11.83	18.8	12.6	18.7	1.3	0.9	12.7	14.1	4.7	24.5
5400.0	11.76	18.8	12.5	18.4	1.3	0.9	12.4	13.9	4.7	24.2
5500.0	11.70	18.8	12.3	18.3	1.3	0.9	12.2	13.8	4.7	23.6
5600.0	11.63	18.8	12.1	18.2	1.3	0.9	11.9	13.6	4.7	23.7
5700.0	11.57	18.8	12.0	17.9	1.3	0.9	11.9	13.5	4.7	23.4
5800.0	11.49	18.8	11.8	17.6	1.3	0.9	11.8	13.4	4.7	23.1
5900.0	11.42	18.8	11.7	17.4	1.3	0.9	11.7	13.3	4.8	22.5
6000.0	11.34	18.8	11.5	17.2	1.3	0.9	11.3	13.0	4.8	22.9

Typical Performance Data

Note: The following data was taken on the Mini-Circuits Characterization Test Board MB-225-6C+ (Figure 2).

Definitions:

Input Return Loss = S11 (dB)

Gain = S21 (dB)

Isolation = S12 (dB)

Output Return Loss = S22 (dB)

TEST CONDITIONS: $V_{DD} = +5.12V$, $I_{DD} = 84mA$ @ Temperature = +25°C

FREQ	Gain	Isolation	Input Return Loss	Output Return Loss	Stability		1dB Comp. Output	3dB Comp. Output	Noise Figure	IP-3 Output
					K	Measure				
(MHz)	(dB)	(dB)	(dB)	(dB)			(dBm)	(dBm)	(dB)	(dBm)
10.00	13.21	18.8	23.1	42.0	1.2	0.7	17.7	18.5	4.1	31.9
50.00	13.24	18.8	22.9	44.0	1.2	0.7	17.7	18.6	4.2	35.5
100.0	13.23	18.8	22.7	46.0	1.2	0.7	17.7	18.6	4.3	35.0
200.0	13.22	18.8	22.6	44.8	1.2	0.7	17.9	18.7	4.2	35.8
300.0	13.20	18.8	22.8	42.1	1.2	0.7	17.9	18.7	4.2	35.7
400.0	13.19	18.8	22.9	39.4	1.2	0.7	18.0	18.8	4.1	35.7
500.0	13.18	18.8	22.8	40.0	1.2	0.7	18.2	18.9	4.2	35.4
600.0	13.16	18.8	22.9	39.0	1.2	0.7	18.4	19.0	4.1	35.4
700.0	13.14	18.8	22.9	36.3	1.2	0.7	18.5	19.0	4.1	35.4
800.0	13.13	18.8	22.9	35.5	1.2	0.7	18.6	19.1	4.2	35.5
900.0	13.12	18.8	22.9	35.0	1.2	0.7	18.7	19.1	4.2	35.6
1000.0	13.10	18.8	22.8	34.3	1.2	0.7	18.8	19.2	4.2	35.4
1100.0	13.09	18.8	22.7	33.7	1.2	0.7	18.7	19.1	4.2	35.1
1200.0	13.08	18.8	22.4	33.6	1.2	0.7	18.8	19.2	4.3	34.4
1300.0	13.07	18.9	22.2	32.7	1.2	0.8	18.7	19.1	4.3	35.6
1400.0	13.06	18.8	22.2	31.9	1.2	0.8	18.5	19.1	4.2	35.8
1500.0	13.04	18.9	22.0	31.3	1.2	0.8	18.5	19.1	4.2	34.9
1600.0	13.03	18.9	21.7	30.7	1.2	0.8	18.4	19.0	4.3	34.1
1700.0	13.02	18.9	21.4	30.2	1.2	0.8	18.5	19.1	4.3	33.9
1800.0	13.01	18.9	21.2	29.3	1.2	0.8	18.2	18.9	4.3	33.6
1900.0	12.99	18.9	20.9	28.9	1.2	0.8	18.3	18.9	4.3	32.7
2000.0	12.98	18.9	20.6	28.7	1.2	0.8	17.9	18.8	4.3	32.5
2100.0	12.96	18.9	20.2	28.2	1.2	0.8	18.0	18.7	4.3	32.4
2200.0	12.95	18.9	19.9	27.6	1.2	0.8	17.8	18.6	4.3	31.7
2300.0	12.94	18.9	19.6	27.2	1.2	0.8	17.7	18.5	4.4	32.0
2400.0	12.92	18.9	19.4	27.0	1.2	0.8	17.6	18.4	4.4	31.7
2500.0	12.91	18.9	19.1	26.6	1.2	0.8	17.5	18.3	4.4	31.4
2600.0	12.89	18.9	19.0	25.8	1.2	0.8	17.5	18.2	4.4	30.9
2700.0	12.87	18.9	18.7	25.4	1.2	0.8	17.1	17.9	4.4	30.4
2800.0	12.86	18.9	18.4	25.2	1.2	0.8	17.1	17.8	4.4	30.8
2900.0	12.84	18.9	18.1	24.7	1.3	0.8	16.9	17.7	4.4	29.9
3000.0	12.82	18.9	17.9	24.2	1.2	0.8	17.0	17.7	4.4	29.3
3100.0	12.80	18.9	17.5	23.9	1.2	0.8	16.8	17.6	4.5	29.9
3200.0	12.77	18.9	17.2	23.7	1.3	0.8	16.6	17.4	4.5	29.5
3300.0	12.75	18.9	17.0	23.3	1.3	0.8	16.3	17.2	4.5	29.3
3400.0	12.72	18.9	16.8	22.8	1.3	0.8	16.2	17.0	4.5	28.7
3500.0	12.70	18.9	16.5	22.5	1.3	0.8	16.3	17.2	4.5	28.8
3600.0	12.67	18.9	16.3	22.5	1.3	0.8	16.1	17.0	4.5	28.0
3700.0	12.64	18.9	16.0	22.2	1.3	0.8	15.9	16.8	4.6	28.4
3800.0	12.62	18.9	15.7	21.9	1.3	0.8	15.7	16.6	4.5	27.2
3900.0	12.58	18.9	15.5	21.6	1.3	0.8	15.5	16.4	4.5	26.7
4000.0	12.55	18.9	15.3	21.5	1.3	0.8	15.5	16.4	4.5	26.9
4100.0	12.52	18.9	15.1	21.3	1.3	0.8	15.3	16.3	4.5	27.6
4200.0	12.48	18.9	14.9	20.9	1.3	0.8	15.2	16.2	4.6	27.2
4300.0	12.45	18.9	14.7	20.7	1.3	0.8	14.9	15.9	4.6	26.3
4400.0	12.40	18.9	14.5	20.6	1.3	0.8	14.6	15.7	4.6	27.4
4500.0	12.37	18.9	14.3	20.3	1.3	0.8	14.6	15.7	4.6	26.2
4600.0	12.32	18.9	14.1	20.0	1.3	0.8	14.4	15.7	4.7	26.3
4700.0	12.28	18.9	14.0	19.8	1.3	0.8	14.3	15.6	4.7	26.1
4800.0	12.23	18.9	13.8	19.7	1.3	0.8	14.3	15.5	4.7	25.6
4900.0	12.19	18.9	13.6	19.4	1.3	0.9	13.9	15.1	4.7	24.6
5000.0	12.13	18.9	13.4	19.1	1.3	0.9	13.7	15.0	4.7	25.4
5100.0	12.08	18.9	13.2	18.9	1.3	0.9	13.7	15.0	4.7	25.1
5200.0	12.02	18.9	13.0	18.8	1.3	0.9	13.6	15.0	4.8	25.0
5300.0	11.96	18.9	12.8	18.5	1.3	0.9	13.4	14.8	4.9	24.8
5400.0	11.91	18.9	12.7	18.2	1.3	0.9	13.2	14.6	4.8	24.7
5500.0	11.85	18.9	12.5	18.0	1.3	0.9	13.0	14.5	4.8	24.1
5600.0	11.78	18.9	12.3	17.9	1.3	0.9	12.8	14.3	4.8	24.2
5700.0	11.72	18.9	12.1	17.6	1.3	0.9	12.7	14.2	4.9	23.9
5800.0	11.65	18.9	12.0	17.3	1.3	0.9	12.6	14.1	4.9	23.5
5900.0	11.58	18.9	11.8	17.2	1.3	0.9	12.5	14.0	4.9	23.0
6000.0	11.51	18.9	11.7	17.0	1.3	0.9	12.1	13.7	4.9	23.4

Typical Performance Data

Note: The following data was taken on the Mini-Circuits Characterization Test Board MB-225-6C+ (Figure 2).

Definitions:

Input Return Loss = S11 (dB)

Gain = S21 (dB)

Isolation = S12 (dB)

Output Return Loss = S22 (dB)

TEST CONDITIONS: $V_{DD} = +5.2V$, $I_{DD} = 70.0mA$ @ Temperature = $-55^{\circ}C$

FREQ	Gain	Isolation	Input Return Loss	Output Return Loss	Stability		1dB Comp. Output	3dB Comp. Output	Noise Figure	IP-3 Output
					K	Measure				
(MHz)	(dB)	(dB)	(dB)	(dB)			(dBm)	(dBm)	(dB)	(dBm)
10.00	13.29	18.9	22.6	40.3	1.2	0.7	18.1	18.6	3.2	30.0
50.00	13.30	18.9	22.4	41.3	1.2	0.7	17.9	18.4	3.4	34.6
100.0	13.29	18.8	22.2	42.4	1.2	0.7	17.9	18.4	3.5	34.9
200.0	13.27	18.8	22.1	41.1	1.2	0.7	18.0	18.5	3.4	35.2
300.0	13.25	18.8	22.0	40.4	1.2	0.7	18.0	18.4	3.3	36.6
400.0	13.24	18.8	22.2	39.4	1.2	0.7	18.0	18.5	3.3	36.6
500.0	13.23	18.9	22.2	40.2	1.2	0.7	18.2	18.6	3.4	36.7
600.0	13.21	18.8	22.3	40.0	1.2	0.7	18.2	18.7	3.3	36.4
700.0	13.19	18.8	22.4	38.2	1.2	0.7	18.1	18.6	3.3	36.2
800.0	13.18	18.8	22.4	36.7	1.2	0.7	18.1	18.6	3.4	35.6
900.0	13.16	18.8	22.4	35.5	1.2	0.7	18.1	18.7	3.4	35.0
1000.0	13.14	18.8	22.3	35.3	1.2	0.7	18.1	18.7	3.4	36.2
1100.0	13.13	18.8	22.2	34.7	1.2	0.7	18.0	18.6	3.4	36.0
1200.0	13.12	18.8	22.0	34.0	1.2	0.7	18.0	18.5	3.4	34.8
1300.0	13.10	18.8	21.9	33.2	1.2	0.7	17.9	18.5	3.4	35.5
1400.0	13.08	18.9	21.7	32.9	1.2	0.7	18.1	18.6	3.4	35.9
1500.0	13.07	18.9	21.5	32.2	1.2	0.7	17.9	18.4	3.4	34.8
1600.0	13.06	18.8	21.4	31.2	1.2	0.8	17.9	18.4	3.4	33.7
1700.0	13.04	18.9	21.1	30.7	1.2	0.8	17.8	18.3	3.4	34.5
1800.0	13.02	18.9	20.8	30.1	1.2	0.8	17.8	18.3	3.4	34.4
1900.0	13.01	18.9	20.6	29.6	1.2	0.8	17.9	18.4	3.4	34.0
2000.0	13.00	18.9	20.3	29.1	1.2	0.8	17.8	18.3	3.5	33.5
2100.0	12.98	18.9	20.0	28.6	1.2	0.8	17.8	18.2	3.5	33.6
2200.0	12.96	18.9	19.7	28.2	1.2	0.8	17.7	18.2	3.5	32.6
2300.0	12.95	18.9	19.4	27.9	1.2	0.8	17.7	18.2	3.5	32.7
2400.0	12.93	18.9	19.2	27.5	1.2	0.8	17.6	18.1	3.5	32.2
2500.0	12.91	18.9	18.9	27.3	1.2	0.8	17.5	18.1	3.5	32.1
2600.0	12.90	18.9	18.8	26.6	1.2	0.8	17.5	18.0	3.5	31.9
2700.0	12.88	18.9	18.5	26.2	1.2	0.8	17.3	17.9	3.5	31.5
2800.0	12.87	18.9	18.3	25.9	1.2	0.8	17.2	17.8	3.5	31.7
2900.0	12.84	18.9	18.0	25.5	1.2	0.8	17.1	17.8	3.5	30.9
3000.0	12.82	18.9	17.8	25.0	1.2	0.8	17.1	17.8	3.5	30.9
3100.0	12.80	18.9	17.5	24.7	1.2	0.8	16.9	17.7	3.6	30.3
3200.0	12.78	18.9	17.2	24.3	1.2	0.8	16.8	17.5	3.6	30.9
3300.0	12.76	18.9	16.9	23.9	1.2	0.8	16.6	17.4	3.6	30.1
3400.0	12.73	18.9	16.7	23.4	1.2	0.8	16.4	17.2	3.6	30.2
3500.0	12.71	18.9	16.4	23.1	1.2	0.8	16.5	17.4	3.7	30.1
3600.0	12.68	18.9	16.2	22.9	1.2	0.8	16.3	17.2	3.6	29.6
3700.0	12.65	18.9	16.0	22.6	1.2	0.8	16.2	17.0	3.7	29.5
3800.0	12.62	18.9	15.7	22.3	1.2	0.8	15.9	16.8	3.6	28.8
3900.0	12.59	18.9	15.5	21.9	1.2	0.8	15.7	16.7	3.7	28.0
4000.0	12.55	18.9	15.2	21.7	1.2	0.8	15.6	16.7	3.7	28.2
4100.0	12.52	18.9	15.0	21.5	1.2	0.8	15.4	16.6	3.7	28.7
4200.0	12.49	18.9	14.8	21.2	1.2	0.8	15.3	16.5	3.6	28.5
4300.0	12.45	18.8	14.6	20.9	1.2	0.8	15.0	16.2	3.7	27.6
4400.0	12.41	18.8	14.4	20.7	1.2	0.8	14.8	16.0	3.7	28.4
4500.0	12.38	18.9	14.2	20.3	1.2	0.8	14.7	16.0	3.7	27.3
4600.0	12.33	18.8	14.0	20.1	1.2	0.8	14.5	15.9	3.7	27.3
4700.0	12.30	18.9	13.9	19.9	1.2	0.8	14.5	15.9	3.8	27.1
4800.0	12.25	18.9	13.7	19.7	1.2	0.8	14.4	15.8	3.8	26.8
4900.0	12.20	18.8	13.5	19.4	1.2	0.8	14.0	15.4	3.8	25.9
5000.0	12.15	18.8	13.3	19.2	1.2	0.8	13.8	15.3	3.8	26.5
5100.0	12.11	18.8	13.1	19.0	1.2	0.9	13.9	15.3	3.8	26.4
5200.0	12.06	18.8	12.9	18.9	1.2	0.9	13.8	15.2	3.9	26.3
5300.0	12.00	18.8	12.7	18.6	1.2	0.9	13.6	15.1	3.9	26.0
5400.0	11.95	18.8	12.6	18.4	1.3	0.9	13.3	14.8	3.9	25.8
5500.0	11.90	18.8	12.4	18.2	1.3	0.9	13.1	14.7	3.9	25.4
5600.0	11.84	18.8	12.2	18.1	1.3	0.9	12.9	14.5	3.9	25.4
5700.0	11.77	18.8	12.1	17.8	1.3	0.9	12.8	14.4	3.9	25.3
5800.0	11.71	18.8	11.9	17.6	1.3	0.9	12.8	14.4	3.9	24.7
5900.0	11.65	18.8	11.7	17.4	1.3	0.9	12.6	14.3	4.0	24.2
6000.0	11.58	18.8	11.6	17.2	1.3	0.9	12.3	13.9	4.0	24.6

Typical Performance Data

Note: The following data was taken on the Mini-Circuits Characterization Test Board MB-225-6C+ (Figure 2).

Definitions:

Input Return Loss = S11 (dB)

Gain = S21 (dB)

Isolation = S12 (dB)

Output Return Loss = S22 (dB)

TEST CONDITIONS: VDD = +4.8V, IDD = 70.0mA @ Temperature = +85°C

FREQ	Gain	Isolation	Input Return Loss	Output Return Loss	Stability		1dB Comp. Output	3dB Comp. Output	Noise Figure	IP-3 Output
					K	Measure				
(MHz)	(dB)	(dB)	(dB)	(dB)			(dBm)	(dBm)	(dB)	(dBm)
10.00	13.06	18.8	22.6	37.66	1.23	0.74	16.9	17.8	4.5	29.0
50.00	13.07	18.7	22.5	40.95	1.22	0.73	17.1	17.9	4.6	33.1
100.0	13.06	18.7	22.3	40.2	1.22	0.74	16.9	17.7	4.8	33.7
200.0	13.05	18.7	22.4	40.2	1.22	0.74	17.1	17.8	4.7	34.8
300.0	13.04	18.8	22.4	39.3	1.22	0.74	17.1	17.7	4.6	34.1
400.0	13.01	18.7	22.4	37.8	1.22	0.74	17.2	17.8	4.6	33.6
500.0	13.00	18.7	22.3	38.6	1.23	0.74	17.3	17.9	4.7	34.1
600.0	12.99	18.7	22.3	37.9	1.23	0.75	17.4	18.0	4.6	34.4
700.0	12.97	18.7	22.2	37.0	1.23	0.75	17.5	17.9	4.6	34.6
800.0	12.96	18.8	22.2	36.5	1.23	0.75	17.5	18.0	4.7	34.8
900.0	12.95	18.7	22.2	36.2	1.23	0.75	17.4	18.0	4.7	34.1
1000.0	12.93	18.8	22.1	35.8	1.24	0.75	17.5	18.0	4.7	34.6
1100.0	12.92	18.8	21.9	35.4	1.24	0.75	17.3	17.9	4.7	34.0
1200.0	12.91	18.8	21.7	34.8	1.24	0.76	17.3	17.9	4.7	34.2
1300.0	12.91	18.8	21.6	33.8	1.24	0.76	17.3	17.9	4.8	33.6
1400.0	12.89	18.8	21.5	33.4	1.24	0.76	17.3	17.9	4.7	34.3
1500.0	12.88	18.8	21.3	32.7	1.24	0.76	17.2	17.8	4.7	33.2
1600.0	12.87	18.8	21.1	31.7	1.25	0.76	17.1	17.7	4.8	32.4
1700.0	12.86	18.8	20.8	31.2	1.25	0.77	17.1	17.7	4.8	31.8
1800.0	12.85	18.8	20.6	30.6	1.25	0.77	16.9	17.6	4.8	32.1
1900.0	12.84	18.8	20.4	30.0	1.25	0.77	17.0	17.6	4.8	31.5
2000.0	12.83	18.8	20.1	29.3	1.25	0.77	16.7	17.5	4.7	30.8
2100.0	12.82	18.8	19.8	28.6	1.25	0.77	16.7	17.4	4.8	31.1
2200.0	12.80	18.8	19.5	28.0	1.25	0.78	16.6	17.3	4.8	30.7
2300.0	12.79	18.8	19.2	27.5	1.25	0.78	16.5	17.2	4.8	30.3
2400.0	12.77	18.9	18.9	27.1	1.26	0.78	16.4	17.1	4.9	30.2
2500.0	12.76	18.9	18.6	26.7	1.26	0.78	16.2	17.0	4.9	29.5
2600.0	12.73	18.9	18.4	26.1	1.26	0.79	16.2	17.0	4.8	29.1
2700.0	12.72	18.9	18.1	25.7	1.26	0.79	15.9	16.7	4.9	28.9
2800.0	12.70	18.9	17.8	25.3	1.26	0.79	15.8	16.6	4.9	28.4
2900.0	12.68	18.9	17.5	24.9	1.26	0.79	15.6	16.5	4.9	27.9
3000.0	12.66	18.9	17.2	24.5	1.26	0.80	15.6	16.5	4.9	27.8
3100.0	12.63	18.9	16.9	24.1	1.26	0.80	15.4	16.4	5.0	27.8
3200.0	12.61	18.9	16.7	23.8	1.26	0.80	15.2	16.2	5.0	27.5
3300.0	12.58	18.9	16.4	23.5	1.26	0.81	15.0	15.9	5.0	27.3
3400.0	12.55	18.9	16.2	23.2	1.26	0.81	14.8	15.8	5.0	27.1
3500.0	12.53	18.9	15.9	22.9	1.26	0.81	14.9	15.9	5.0	26.9
3600.0	12.49	18.9	15.7	22.6	1.27	0.82	14.6	15.7	5.0	26.2
3700.0	12.46	18.9	15.5	22.4	1.27	0.82	14.5	15.5	5.0	26.4
3800.0	12.43	18.9	15.3	22.1	1.27	0.83	14.2	15.3	5.1	25.5
3900.0	12.39	18.9	15.1	21.8	1.27	0.83	14.0	15.1	5.0	25.0
4000.0	12.35	18.9	14.9	21.7	1.27	0.83	13.9	15.1	5.1	25.0
4100.0	12.31	18.9	14.7	21.5	1.27	0.84	13.7	15.0	5.1	25.8
4200.0	12.26	18.9	14.5	21.3	1.27	0.84	13.6	14.9	5.0	25.2
4300.0	12.22	18.9	14.3	21.1	1.27	0.84	13.3	14.6	5.1	24.3
4400.0	12.17	18.9	14.1	20.9	1.28	0.85	13.0	14.4	5.1	25.3
4500.0	12.12	18.9	13.9	20.7	1.28	0.85	12.9	14.3	5.2	24.1
4600.0	12.07	18.9	13.8	20.4	1.28	0.86	12.8	14.3	5.2	24.1
4700.0	12.01	18.9	13.6	20.2	1.28	0.86	12.7	14.2	5.2	24.0
4800.0	11.95	18.9	13.4	20.0	1.29	0.87	12.6	14.1	5.2	23.5
4900.0	11.89	18.9	13.2	19.8	1.29	0.87	12.2	13.7	5.2	22.5
5000.0	11.83	18.9	13.1	19.5	1.29	0.88	12.1	13.6	5.3	23.3
5100.0	11.76	18.9	12.9	19.4	1.30	0.88	12.0	13.6	5.2	23.0
5200.0	11.69	18.9	12.7	19.2	1.30	0.89	11.9	13.5	5.3	22.9
5300.0	11.62	18.9	12.6	18.9	1.31	0.89	11.7	13.3	5.4	22.9
5400.0	11.55	18.9	12.4	18.6	1.31	0.89	11.5	13.1	5.3	22.5
5500.0	11.47	18.9	12.2	18.4	1.31	0.90	11.3	13.0	5.4	22.0
5600.0	11.39	18.9	12.1	18.3	1.32	0.91	11.1	12.8	5.4	22.0
5700.0	11.31	18.9	11.9	18.0	1.32	0.91	11.0	12.7	5.4	21.6
5800.0	11.23	18.9	11.7	17.8	1.33	0.92	10.9	12.6	5.4	21.3
5900.0	11.14	18.9	11.6	17.6	1.33	0.92	10.7	12.5	5.5	20.8
6000.0	11.05	18.9	11.4	17.4	1.34	0.93	10.4	12.2	5.5	21.3

Typical Performance Data

Note: The following data was taken on the Mini-Circuits Evaluation Board TB-LEE1-6C+ (Figure 3).

Definitions:

Input Return Loss = S11 (dB)

Gain = S21 (dB)

Isolation = S12 (dB)

Output Return Loss = S22 (dB)

TEST CONDITIONS: $V_{CC} = +8V$, $I_{CC} = 71.5mA$ @ Temperature = $+25^{\circ}C$

FREQ	Gain	Isolation	Input Return Loss	Output Return Loss	Stability		1dB Comp. Output	3dB Comp. Output	Noise Figure	IP-3 Output
					K	Measure				
(MHz)	(dB)	(dB)	(dB)	(dB)			(dBm)	(dBm)	(dB)	(dBm)
10.00	12.33	19.7	19.6	15.3	1.3	0.8	16.4	17.2	4.3	30.1
50.00	13.10	18.9	21.9	41.9	1.2	0.7	17.5	18.2	4.1	32.5
100.00	13.14	18.8	22.2	47.7	1.2	0.7	17.5	18.3	4.2	35.8
200.00	13.12	18.8	22.3	37.7	1.2	0.7	17.7	18.4	4.2	35.6
300.00	13.10	18.8	22.7	33.3	1.2	0.7	17.8	18.5	4.2	35.2
400.00	13.06	18.8	23.1	31.0	1.2	0.7	17.9	18.5	4.2	36.6
500.00	13.03	18.8	23.1	29.3	1.2	0.7	17.9	18.5	4.2	36.0
600.00	13.00	18.8	23.4	27.9	1.2	0.7	17.9	18.5	4.2	36.9
700.00	12.98	18.8	23.7	26.8	1.2	0.7	18.0	18.6	4.2	36.6
800.00	12.95	18.9	24.1	25.2	1.2	0.7	17.9	18.5	4.2	36.3
900.00	12.94	18.8	24.2	24.3	1.2	0.7	17.9	18.6	4.2	34.7
1000.00	12.93	18.8	24.6	23.7	1.2	0.7	17.9	18.5	4.2	35.4
1100.00	12.90	18.8	24.9	23.0	1.2	0.7	17.8	18.5	4.2	34.5
1200.00	12.89	18.8	25.1	22.3	1.2	0.7	17.8	18.5	4.2	36.1
1300.00	12.87	18.8	25.4	22.0	1.2	0.7	17.8	18.4	4.2	34.6
1400.00	12.85	18.9	25.7	21.5	1.2	0.7	17.7	18.4	4.1	34.1
1500.00	12.84	18.8	25.7	21.2	1.2	0.7	17.6	18.4	4.2	34.2
1600.00	12.82	18.9	25.6	21.0	1.2	0.7	17.7	18.3	4.2	34.0
1700.00	12.81	18.8	25.4	20.7	1.2	0.7	17.6	18.3	4.2	35.0
1800.00	12.79	18.9	24.9	20.4	1.2	0.7	17.5	18.2	4.1	33.4
1900.00	12.76	18.9	24.3	20.2	1.2	0.8	17.6	18.3	4.2	32.7
2000.00	12.74	18.9	23.4	20.2	1.2	0.8	17.4	18.2	4.2	33.1
2100.00	12.71	18.9	22.5	20.3	1.2	0.8	17.4	18.2	4.2	32.5
2200.00	12.70	18.9	21.6	20.1	1.2	0.8	17.3	18.1	4.2	34.3
2300.00	12.68	18.9	20.7	20.1	1.2	0.8	17.4	18.1	4.2	33.2
2400.00	12.65	18.9	19.7	20.1	1.2	0.8	17.3	18.1	4.3	31.3
2500.00	12.63	18.9	18.7	20.1	1.2	0.8	17.2	18.0	4.3	31.6
2600.00	12.60	18.9	17.8	20.0	1.2	0.8	17.1	17.9	4.2	31.4
2700.00	12.58	18.9	16.9	19.8	1.2	0.8	17.1	17.9	4.3	31.1
2800.00	12.54	19.0	16.2	19.7	1.2	0.8	16.9	17.8	4.3	30.7
2900.00	12.50	19.0	15.4	19.5	1.2	0.8	16.9	17.8	4.3	30.9
3000.00	12.46	19.0	14.7	19.3	1.2	0.8	16.8	17.7	4.3	30.1
3100.00	12.42	19.0	14.1	19.0	1.2	0.8	16.7	17.6	4.3	30.7
3200.00	12.38	19.0	13.5	18.7	1.3	0.8	16.5	17.4	4.4	30.4
3300.00	12.33	19.0	13.0	18.4	1.3	0.8	16.3	17.4	4.4	29.0
3400.00	12.28	19.1	12.5	18.1	1.3	0.8	16.2	17.2	4.4	29.4
3500.00	12.23	19.1	12.0	17.9	1.3	0.8	16.1	17.1	4.5	29.0
3600.00	12.18	19.1	11.6	17.6	1.3	0.8	15.9	17.0	4.4	29.0
3700.00	12.13	19.1	11.3	17.4	1.3	0.8	15.6	16.6	4.5	28.3
3800.00	12.09	19.1	11.0	17.3	1.3	0.8	15.5	16.6	4.5	28.1
3900.00	12.05	19.1	10.7	17.1	1.3	0.8	15.3	16.5	4.5	28.3
4000.00	12.00	19.1	10.4	17.1	1.3	0.9	15.3	16.4	4.5	27.9
4100.00	11.96	19.2	10.2	16.9	1.3	0.9	15.1	16.3	4.5	28.0
4200.00	11.92	19.1	10.0	16.9	1.3	0.9	14.9	16.1	4.5	27.4
4300.00	11.86	19.2	9.9	16.9	1.3	0.9	14.8	16.1	4.5	27.6
4400.00	11.83	19.2	9.7	17.0	1.3	0.9	14.6	16.0	4.6	27.3
4500.00	11.80	19.1	9.6	17.0	1.3	0.9	14.6	15.9	4.6	26.7
4600.00	11.75	19.1	9.5	17.1	1.3	0.9	14.5	15.8	4.6	26.9
4700.00	11.73	19.1	9.4	17.3	1.3	0.9	14.2	15.6	4.6	26.5
4800.00	11.69	19.1	9.3	17.5	1.3	0.9	13.9	15.3	4.6	26.4
4900.00	11.66	19.1	9.3	17.7	1.3	0.9	13.8	15.3	4.7	26.1
5000.00	11.62	19.1	9.3	17.9	1.3	0.9	13.7	15.3	4.7	25.9
5100.00	11.60	19.0	9.3	18.3	1.3	0.9	13.4	14.9	4.6	25.5
5200.00	11.56	19.0	9.3	18.8	1.3	0.9	13.1	14.7	4.7	25.2
5300.00	11.53	19.0	9.3	19.2	1.3	0.9	13.0	14.6	4.7	24.9
5400.00	11.48	19.0	9.3	19.7	1.3	0.9	12.9	14.5	4.7	24.9
5500.00	11.45	18.9	9.4	20.3	1.3	0.9	12.8	14.4	4.7	24.6
5600.00	11.40	18.9	9.4	21.0	1.3	0.9	12.6	14.2	4.8	24.5
5700.00	11.35	18.9	9.5	21.6	1.3	0.9	12.4	14.1	4.7	24.3
5800.00	11.29	18.9	9.6	22.0	1.3	0.9	12.1	13.8	4.8	23.8
5900.00	11.24	18.9	9.7	22.4	1.3	0.9	11.9	13.6	4.8	23.3
6000.00	11.17	18.9	9.8	22.8	1.3	0.9	11.8	13.5	4.8	23.3

Typical Performance Data

Note: The following data was taken on the Mini-Circuits Evaluation Board TB-LEE1-6C+ (Figure 3).

Definitions:

Input Return Loss = S11 (dB)

Gain = S21 (dB)

Isolation = S12 (dB)

Output Return Loss = S22 (dB)

TEST CONDITIONS: $V_{CC} = +8V$, $I_{CC} = 66.8mA$ @ Temperature = $-55^{\circ}C$

FREQ	Gain	Isolation	Input Return Loss	Output Return Loss	Stability		1dB Comp. Output	3dB Comp. Output	Noise Figure	IP-3 Output
					K	Measure				
(MHz)	(dB)	(dB)	(dB)	(dB)			(dBm)	(dBm)	(dB)	(dBm)
10.00	12.37	19.8	19.3	15.0	1.3	0.8	16.7	17.3	3.6	29.3
50.00	13.22	18.9	21.7	40.8	1.2	0.7	17.6	18.2	3.3	36.3
100.0	13.24	18.9	21.9	47.8	1.2	0.7	17.7	18.3	3.5	34.9
200.0	13.23	18.9	21.8	37.2	1.2	0.7	17.9	18.5	3.4	35.3
300.0	13.22	18.9	22.2	33.6	1.2	0.7	17.9	18.5	3.4	36.1
400.0	13.20	18.9	22.7	31.2	1.2	0.7	17.9	18.5	3.4	35.4
500.0	13.16	18.9	22.9	29.5	1.2	0.7	18.0	18.6	3.4	36.1
600.0	13.14	18.9	23.2	27.9	1.2	0.7	17.9	18.6	3.4	37.1
700.0	13.13	18.9	23.7	26.8	1.2	0.7	17.9	18.7	3.3	36.8
800.0	13.08	18.9	24.4	25.5	1.2	0.7	17.8	18.6	3.4	36.5
900.0	13.09	18.8	24.3	24.2	1.2	0.7	17.8	18.6	3.4	34.6
1000.0	13.07	18.9	24.7	23.7	1.2	0.7	17.8	18.6	3.4	36.3
1100.0	13.05	18.9	25.1	23.2	1.2	0.7	17.7	18.5	3.4	34.3
1200.0	13.03	18.9	25.3	22.3	1.2	0.7	17.7	18.5	3.4	36.0
1300.0	13.02	18.9	25.7	22.0	1.2	0.7	17.7	18.5	3.4	35.4
1400.0	13.00	18.9	26.0	21.6	1.2	0.7	17.7	18.4	3.4	34.9
1500.0	13.00	18.8	25.9	21.3	1.2	0.7	17.5	18.4	3.4	34.8
1600.0	12.98	18.8	25.8	21.1	1.2	0.7	17.6	18.4	3.4	35.1
1700.0	12.96	18.9	25.5	20.8	1.2	0.7	17.5	18.3	3.4	34.9
1800.0	12.94	18.9	24.9	20.6	1.2	0.7	17.5	18.3	3.4	34.4
1900.0	12.90	18.9	24.2	20.4	1.2	0.7	17.5	18.3	3.4	35.7
2000.0	12.88	18.9	23.3	20.3	1.2	0.7	17.4	18.2	3.4	33.3
2100.0	12.86	18.9	22.5	20.3	1.2	0.8	17.5	18.3	3.4	34.7
2200.0	12.85	18.9	21.6	20.3	1.2	0.8	17.5	18.2	3.4	32.9
2300.0	12.83	18.9	20.7	20.2	1.2	0.8	17.5	18.3	3.4	33.2
2400.0	12.81	18.9	19.8	20.2	1.2	0.8	17.3	18.2	3.4	32.7
2500.0	12.79	18.9	18.9	20.2	1.2	0.8	17.2	18.2	3.4	33.2
2600.0	12.77	18.9	18.1	20.2	1.2	0.8	17.1	18.1	3.4	32.6
2700.0	12.74	18.9	17.2	20.1	1.2	0.8	17.2	18.1	3.5	32.4
2800.0	12.70	18.9	16.4	20.2	1.2	0.8	17.1	18.0	3.5	31.9
2900.0	12.68	18.9	15.7	20.1	1.2	0.8	17.0	18.0	3.5	32.4
3000.0	12.64	18.9	15.0	19.9	1.2	0.8	16.9	17.9	3.5	31.5
3100.0	12.61	19.0	14.3	19.6	1.2	0.8	16.7	17.8	3.5	31.9
3200.0	12.56	19.0	13.7	19.3	1.2	0.8	16.7	17.8	3.5	31.2
3300.0	12.52	19.0	13.2	19.0	1.2	0.8	16.6	17.7	3.5	30.7
3400.0	12.47	19.0	12.7	18.6	1.2	0.8	16.5	17.6	3.6	31.0
3500.0	12.42	19.0	12.2	18.4	1.2	0.8	16.5	17.6	3.5	30.6
3600.0	12.37	19.0	11.7	18.1	1.2	0.8	16.3	17.4	3.6	30.1
3700.0	12.32	19.1	11.4	17.8	1.2	0.8	16.1	17.2	3.6	29.9
3800.0	12.27	19.1	11.0	17.5	1.2	0.8	16.0	17.2	3.6	29.9
3900.0	12.23	19.1	10.7	17.3	1.2	0.8	15.8	17.1	3.6	29.7
4000.0	12.18	19.1	10.5	17.2	1.2	0.8	15.8	17.0	3.6	29.0
4100.0	12.14	19.1	10.2	17.1	1.2	0.9	15.6	16.9	3.6	29.0
4200.0	12.11	19.1	10.0	17.0	1.2	0.9	15.4	16.7	3.7	28.6
4300.0	12.07	19.1	9.9	16.9	1.2	0.9	15.3	16.7	3.7	28.8
4400.0	12.04	19.1	9.7	17.0	1.2	0.9	15.2	16.6	3.7	28.5
4500.0	12.02	19.1	9.6	16.9	1.2	0.9	15.1	16.5	3.7	28.3
4600.0	11.97	19.1	9.4	17.0	1.2	0.9	15.1	16.5	3.7	28.3
4700.0	11.96	19.1	9.4	17.1	1.2	0.9	14.8	16.2	3.8	27.8
4800.0	11.93	19.0	9.3	17.3	1.2	0.9	14.5	16.0	3.7	27.8
4900.0	11.90	19.0	9.2	17.4	1.2	0.9	14.4	15.9	3.8	27.3
5000.0	11.87	19.0	9.2	17.6	1.2	0.9	14.3	15.9	3.8	27.3
5100.0	11.85	19.0	9.2	17.9	1.2	0.9	14.0	15.5	3.8	26.9
5200.0	11.81	19.0	9.2	18.3	1.2	0.9	13.7	15.3	3.8	26.8
5300.0	11.80	18.9	9.2	18.7	1.2	0.9	13.6	15.3	3.8	26.5
5400.0	11.75	18.9	9.2	19.1	1.2	0.9	13.6	15.2	3.8	26.4
5500.0	11.73	18.9	9.2	19.6	1.2	0.9	13.4	15.1	3.9	26.1
5600.0	11.70	18.8	9.3	20.2	1.2	0.9	13.2	14.9	3.9	26.0
5700.0	11.65	18.8	9.4	20.8	1.2	0.9	13.1	14.8	3.8	25.6
5800.0	11.61	18.8	9.4	21.2	1.3	0.9	12.8	14.5	3.9	25.2
5900.0	11.56	18.8	9.5	21.6	1.3	0.9	12.6	14.3	3.9	24.7
6000.0	11.50	18.8	9.6	22.0	1.3	0.9	12.6	14.2	3.9	24.9

Typical Performance Data

Note: The following data was taken on the Mini-Circuits Evaluation Board TB-LEE1-6C+ (Figure 3).

Definitions:

Input Return Loss = S11 (dB)

Gain = S21 (dB)

Isolation = S12 (dB)

Output Return Loss = S22 (dB)

TEST CONDITIONS: $V_{CC} = +8V$, $I_{CC} = 75.0mA$ @ Temperature = $+85^{\circ}C$

FREQ	Gain	Isolation	Input Return Loss	Output Return Loss	Stability		1dB Comp. Output	3dB Comp. Output	Noise Figure	IP-3 Output
					K	Measure				
(MHz)	(dB)	(dB)	(dB)	(dB)			(dBm)	(dBm)	(dB)	(dBm)
10.00	12.23	19.6	19.9	15.4	1.3	0.8	15.9	16.9	4.9	28.4
50.00	13.02	18.9	22.1	43.4	1.2	0.7	17.1	18.0	4.7	32.3
100.0	13.04	18.8	22.5	48.8	1.2	0.7	17.0	18.0	4.8	36.1
200.0	13.02	18.8	22.7	37.7	1.2	0.7	17.3	18.2	4.8	35.6
300.0	13.01	18.8	22.8	33.2	1.2	0.7	17.4	18.3	4.8	35.8
400.0	12.96	18.8	23.1	30.7	1.2	0.7	17.5	18.3	4.8	36.0
500.0	12.93	18.8	23.1	29.1	1.2	0.7	17.6	18.3	4.8	36.3
600.0	12.90	18.8	23.3	27.6	1.2	0.7	17.6	18.3	4.8	36.5
700.0	12.88	18.8	23.4	26.5	1.2	0.7	17.9	18.4	4.8	36.1
800.0	12.85	18.8	23.7	25.1	1.2	0.7	17.8	18.4	4.8	35.5
900.0	12.84	18.8	23.8	24.2	1.2	0.7	17.9	18.4	4.8	36.8
1000.0	12.82	18.8	24.1	23.6	1.2	0.7	17.8	18.3	4.8	34.9
1100.0	12.80	18.8	24.4	23.0	1.2	0.7	17.7	18.4	4.8	34.5
1200.0	12.79	18.8	24.5	22.3	1.2	0.7	17.7	18.4	4.8	33.7
1300.0	12.77	18.8	24.7	21.9	1.2	0.7	17.7	18.3	4.8	35.0
1400.0	12.75	18.8	24.8	21.4	1.2	0.7	17.5	18.2	4.8	34.4
1500.0	12.75	18.8	24.8	21.1	1.2	0.7	17.6	18.3	4.8	34.1
1600.0	12.72	18.8	24.8	20.9	1.2	0.7	17.5	18.2	4.8	33.3
1700.0	12.71	18.8	24.6	20.6	1.2	0.8	17.4	18.2	4.8	32.4
1800.0	12.69	18.8	24.2	20.3	1.2	0.8	17.3	18.1	4.8	33.5
1900.0	12.66	18.9	23.7	20.1	1.3	0.8	17.3	18.1	4.8	31.9
2000.0	12.64	18.9	23.0	20.0	1.3	0.8	17.2	18.0	4.8	31.9
2100.0	12.62	18.9	22.2	20.0	1.3	0.8	17.1	18.0	4.9	31.4
2200.0	12.60	18.9	21.3	19.9	1.3	0.8	16.9	17.8	4.8	32.3
2300.0	12.58	18.9	20.4	19.8	1.3	0.8	16.9	17.8	4.9	31.0
2400.0	12.55	18.9	19.4	19.8	1.3	0.8	16.9	17.8	4.9	31.0
2500.0	12.53	18.9	18.5	19.8	1.3	0.8	16.9	17.7	4.9	30.5
2600.0	12.50	18.9	17.7	19.6	1.3	0.8	16.8	17.6	4.9	29.5
2700.0	12.47	18.9	16.8	19.4	1.3	0.8	16.6	17.5	4.9	29.7
2800.0	12.43	19.0	16.1	19.3	1.3	0.8	16.4	17.4	4.9	29.3
2900.0	12.40	19.0	15.4	19.1	1.3	0.8	16.4	17.3	4.9	29.4
3000.0	12.35	19.0	14.7	18.9	1.3	0.8	16.3	17.2	4.9	29.1
3100.0	12.32	19.0	14.1	18.7	1.3	0.8	16.2	17.2	5.0	29.2
3200.0	12.27	19.0	13.5	18.5	1.3	0.8	15.9	16.9	5.0	28.4
3300.0	12.23	19.0	13.0	18.3	1.3	0.8	15.8	16.8	5.0	28.0
3400.0	12.16	19.1	12.5	18.1	1.3	0.8	15.6	16.7	5.1	27.9
3500.0	12.12	19.1	12.1	17.9	1.3	0.8	15.5	16.5	5.1	27.5
3600.0	12.07	19.1	11.7	17.6	1.3	0.8	15.3	16.3	5.1	27.5
3700.0	12.01	19.1	11.4	17.5	1.3	0.8	14.9	16.0	5.1	27.1
3800.0	11.97	19.1	11.1	17.4	1.3	0.8	14.8	16.0	5.1	26.6
3900.0	11.92	19.1	10.8	17.3	1.3	0.9	14.7	15.9	5.1	26.5
4000.0	11.86	19.1	10.6	17.3	1.3	0.9	14.6	15.8	5.2	26.2
4100.0	11.81	19.1	10.3	17.2	1.3	0.9	14.4	15.6	5.2	26.2
4200.0	11.77	19.1	10.1	17.3	1.3	0.9	14.2	15.4	5.2	25.8
4300.0	11.71	19.2	10.0	17.3	1.3	0.9	14.1	15.4	5.2	25.6
4400.0	11.67	19.1	9.8	17.4	1.3	0.9	13.9	15.3	5.3	25.6
4500.0	11.63	19.1	9.7	17.5	1.3	0.9	13.8	15.2	5.3	25.4
4600.0	11.57	19.2	9.5	17.6	1.3	0.9	13.8	15.1	5.3	25.1
4700.0	11.53	19.1	9.5	17.7	1.3	0.9	13.5	14.8	5.4	24.8
4800.0	11.48	19.1	9.3	17.9	1.3	0.9	13.1	14.6	5.3	24.5
4900.0	11.43	19.1	9.3	18.2	1.3	0.9	13.0	14.5	5.4	24.3
5000.0	11.40	19.1	9.2	18.4	1.3	0.9	13.0	14.5	5.4	24.3
5100.0	11.36	19.1	9.2	18.8	1.3	0.9	12.6	14.1	5.4	23.8
5200.0	11.30	19.0	9.2	19.2	1.3	0.9	12.3	13.9	5.4	23.5
5300.0	11.27	19.0	9.2	19.7	1.3	0.9	12.2	13.9	5.4	23.3
5400.0	11.20	19.0	9.2	20.2	1.3	0.9	12.1	13.8	5.4	23.2
5500.0	11.16	19.0	9.2	20.8	1.3	0.9	12.0	13.6	5.5	22.9
5600.0	11.10	19.0	9.2	21.4	1.3	0.9	11.7	13.4	5.5	22.7
5700.0	11.03	18.9	9.3	22.1	1.3	0.9	11.6	13.3	5.5	22.5
5800.0	10.97	18.9	9.4	22.5	1.3	0.9	11.3	13.1	5.5	22.1
5900.0	10.90	18.9	9.5	22.9	1.3	0.9	11.1	12.8	5.6	21.7
6000.0	10.81	18.9	9.6	23.3	1.3	0.9	11.0	12.7	5.6	21.6

Typical Performance Curves

Note: The following data was taken on the Mini-Circuits Characterization Test Board MB-225-6C+ (Figure 2).

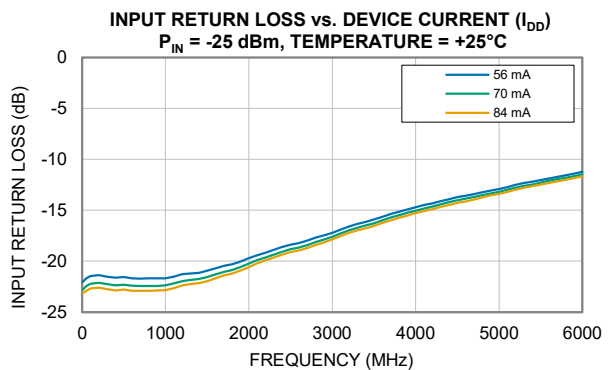
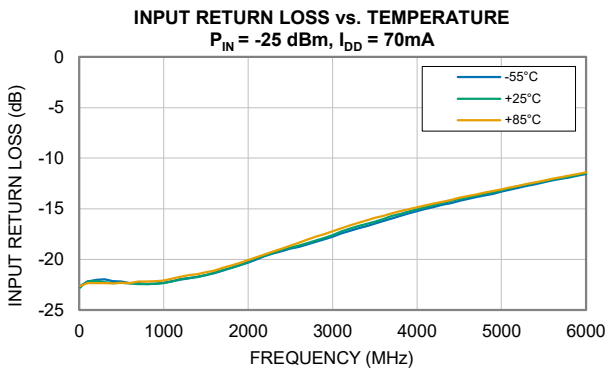
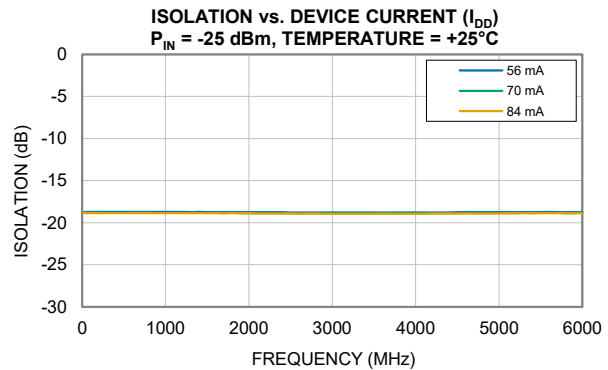
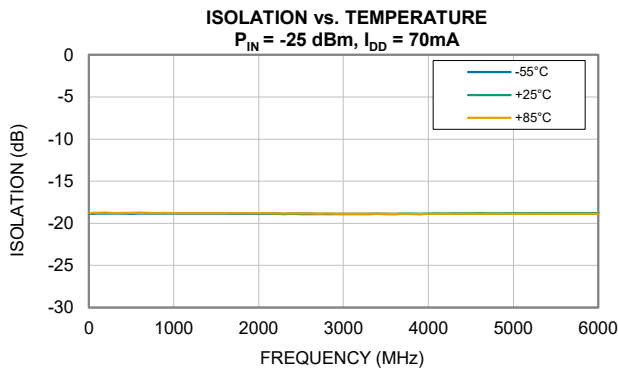
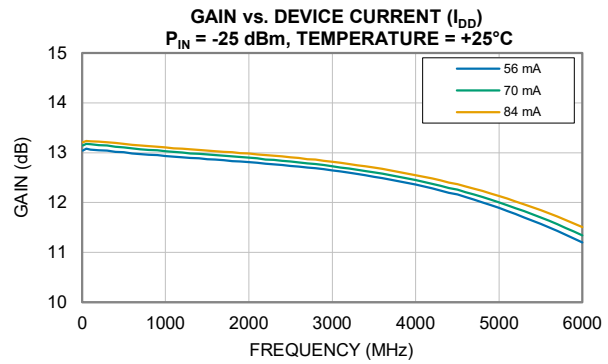
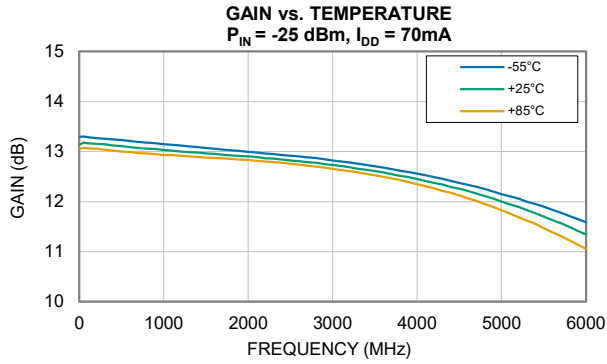

Typical Performance Curves

Note: The following data was taken on the Mini-Circuits Characterization Test Board MB-225-6C+ (Figure 2).

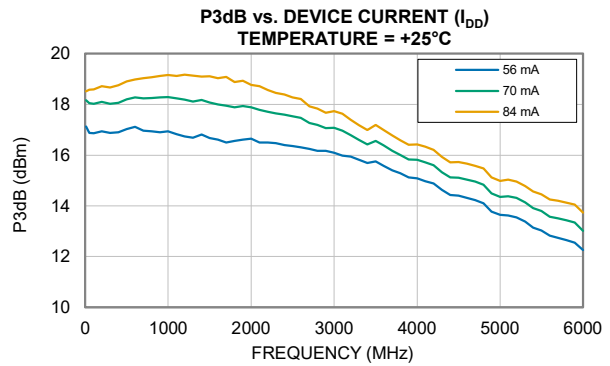
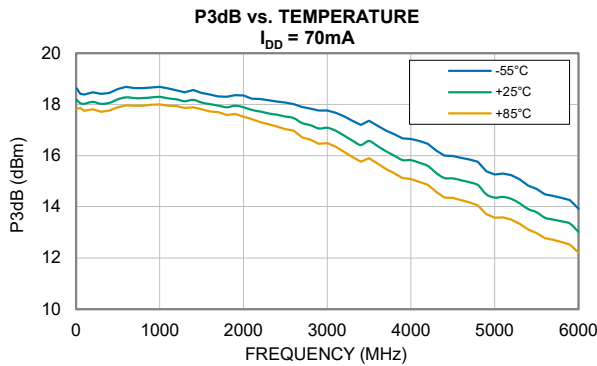
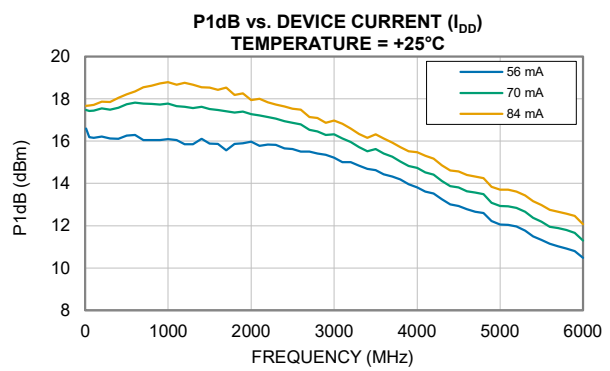
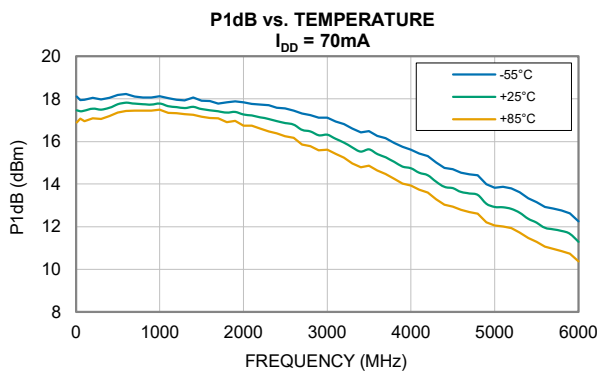
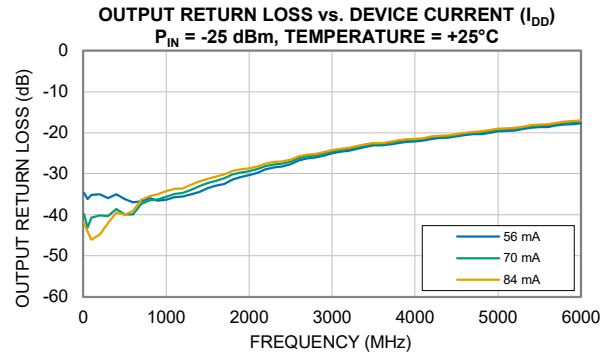
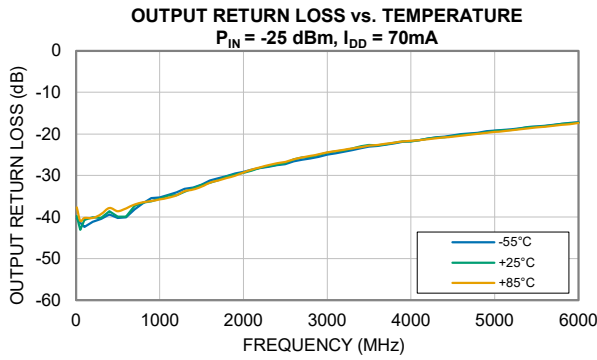

Typical Performance Curves

Note: The following data was taken on the Mini-Circuits Characterization Test Board MB-225-6C+ (Figure 2).

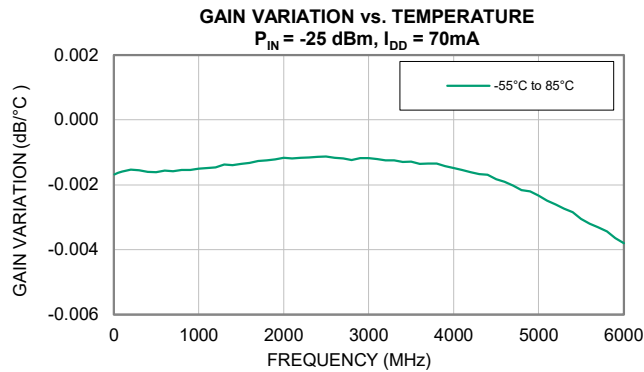
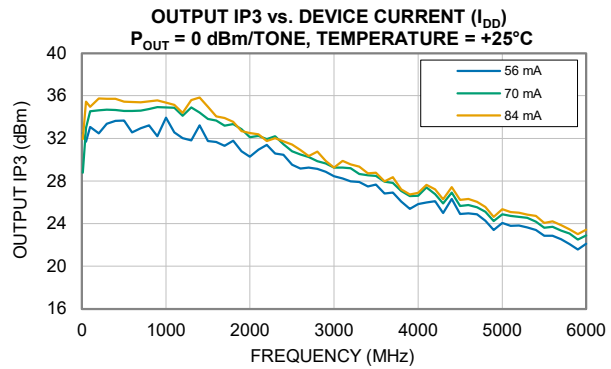
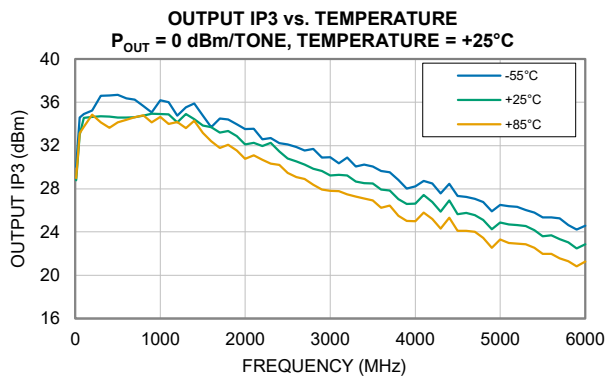
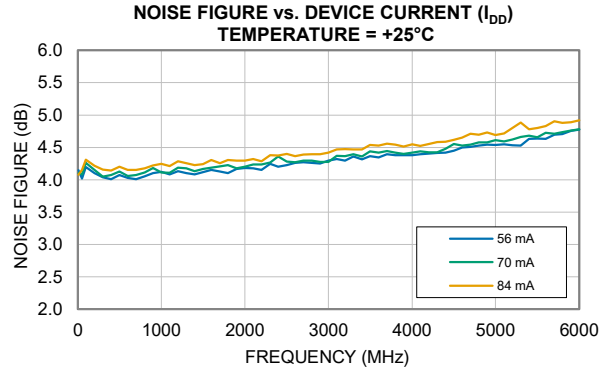
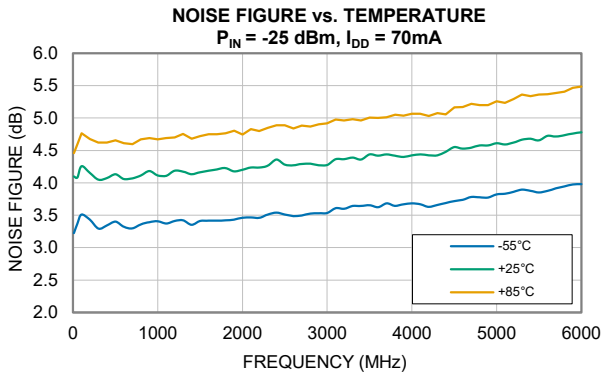

Typical Performance Curves

Note: The following data was taken on the Mini-Circuits Evaluation Board TB-LEE1-6C+ (Figure 3).

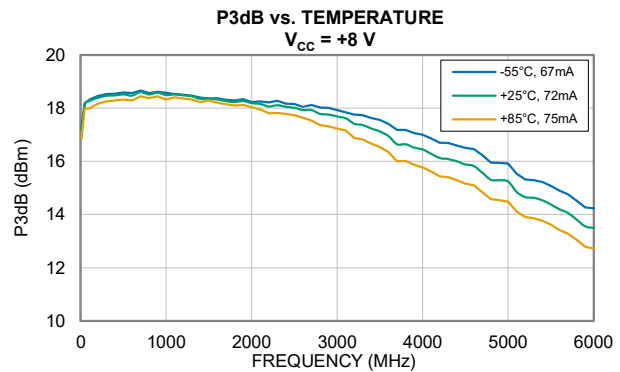
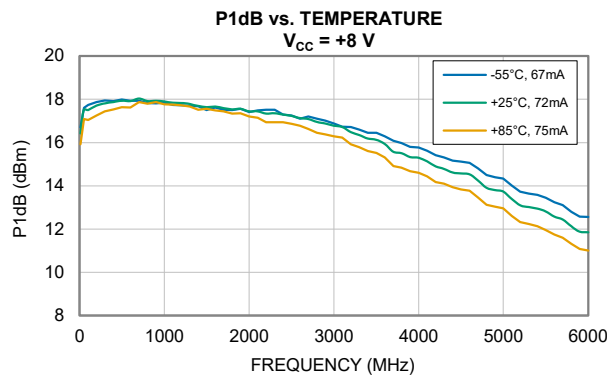
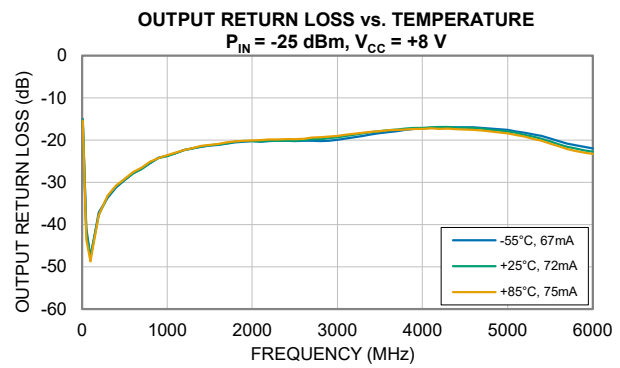
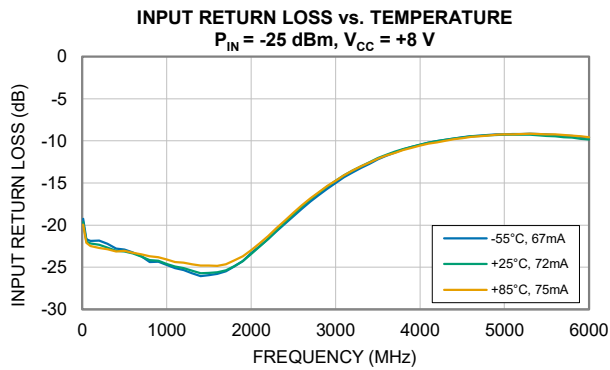
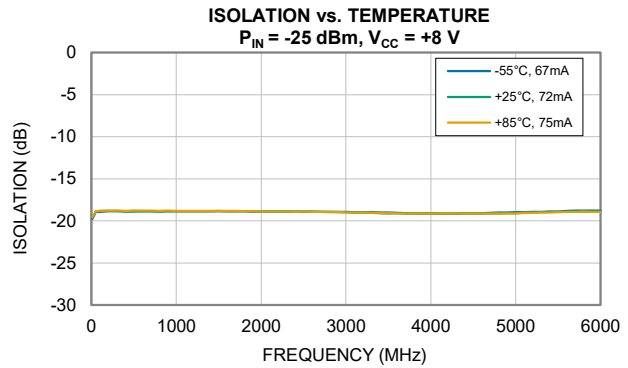
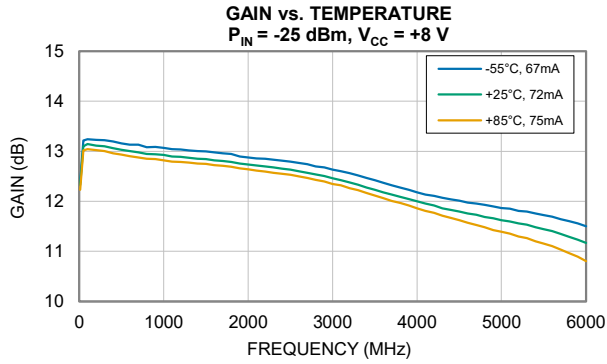

Typical Performance Curves

Note: The following data was taken on the Mini-Circuits Evaluation Board TB-LEE1-6C+ (Figure 3).

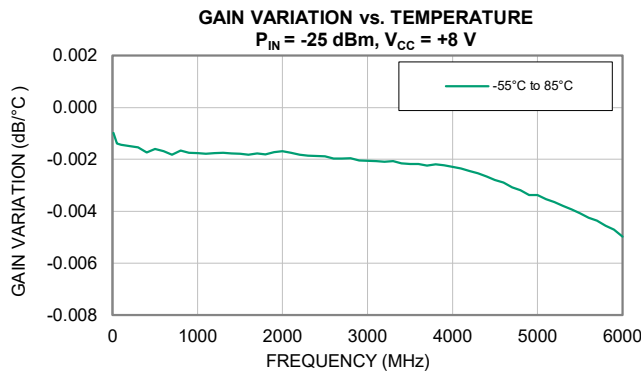
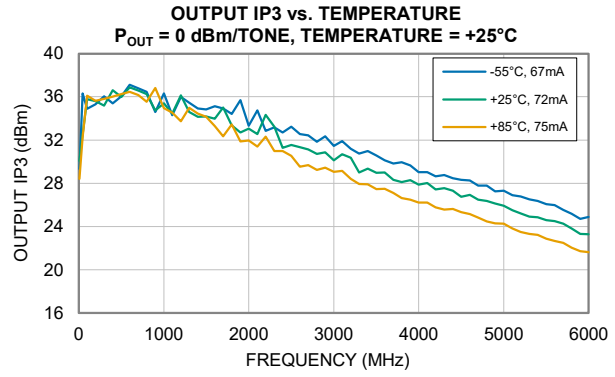
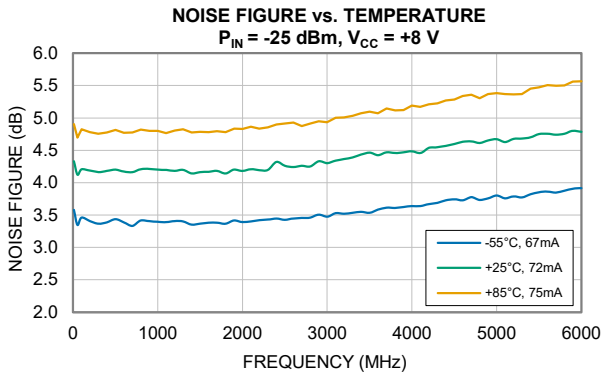

Case Style

KC

Outline Dimensions

KC3011

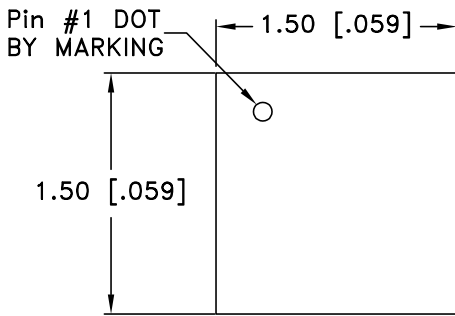

TOP VIEW

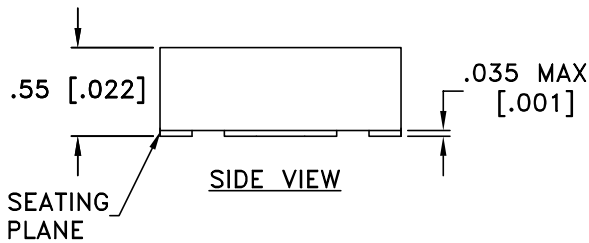

SIDE VIEW

PCB Land Pattern

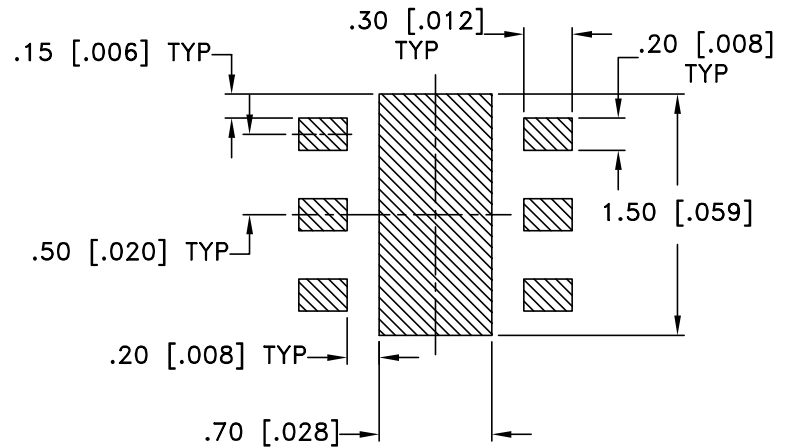

Suggested Layout,
Tolerance to be within ± 0.050 mm

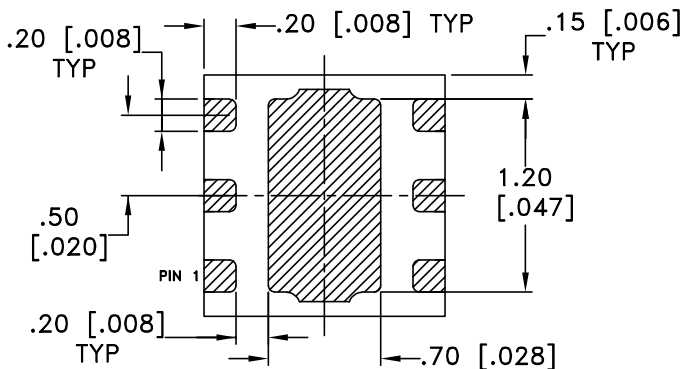

BOTTOM VIEW

NOTES:

1.  DENOTES METALLIZATION

Weight: .0036 grams

Dimensions are in mm [inches]. Tolerances: 2 Pl. ± 0.05 mm

Notes:

1. Case material: Plastic.
2. Termination finish: NiPdAu ($3\mu\text{m}/0.080\mu\text{m}/0.080\mu\text{m}$).



P.O. Box 350166, Brooklyn, New York 11235-0003 (718) 934-4500 Fax (718) 332-4661 For detailed performance specs & shopping online see Mini-Circuits web site



The Design Engineers Search Engine Provides ACTUAL Data Instantly From MINI-CIRCUITS At: www.minicircuits.com

RF/IF MICROWAVE COMPONENTS

Tape & Reel Packaging TR-F66

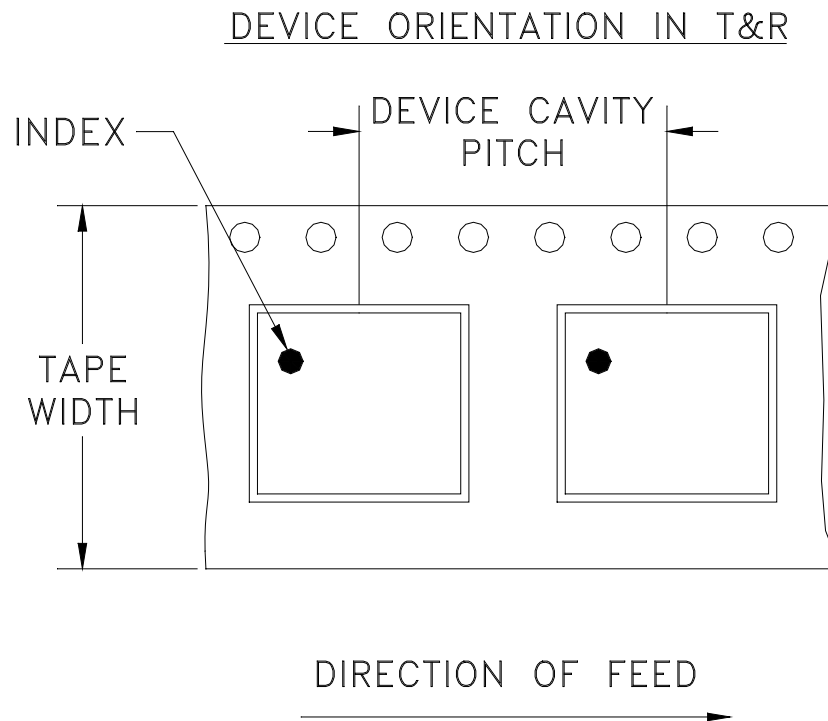

Tape Width, mm	Device Cavity Pitch, mm	Reel Size, inches	Devices per Reel see note	
8	4	7	Small quantity standard	20
				50
				100
				200
				500
		7	Standard	1000, 2000, 3000

Note: Please consult individual model data sheet to determine device per reel availability.

Mini-Circuits carrier tape materials provide protection from ESD (Electro-Static Discharge) during handling and transportation. Tapes are static dissipative and comply with industry standards EIA-481/EIA-541.

Go to: www.minicircuits.com/pages/pdfs/tape.pdf

Mini-Circuits®

INTERNET <http://www.minicircuits.com>

P.O. Box 350166, Brooklyn, New York 11235-0003 (718) 934-4500 Fax (718) 332-4661

Distribution Centers NORTH AMERICA 800-654-7949 • 417-335-5935 • Fax 417-335-5945 • EUROPE 44-1252-832600 • Fax 44-1252-837010

Mini-Circuits ISO 9001 & ISO 14001 Certified

THIRD ANGLE PROJECTION

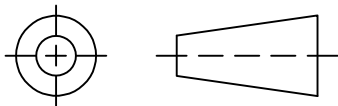

REVISIONS

REV	ECN No.	DESCRIPTION	DATE	DR	AUTH
OR	ECO-028458	NEW RELEASE	02/09/26	ITG	IL

SUGGESTED MOUNTING CONFIGURATION FOR KC3011 CASE STYLE

3 LAYER STACKUP DETAIL

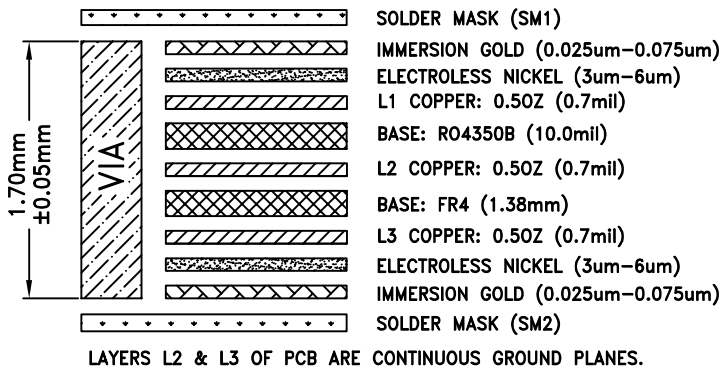

COMPONENT	SIZE
C1, C2	0402
C3	0805
R1	1210
BT1	N/A

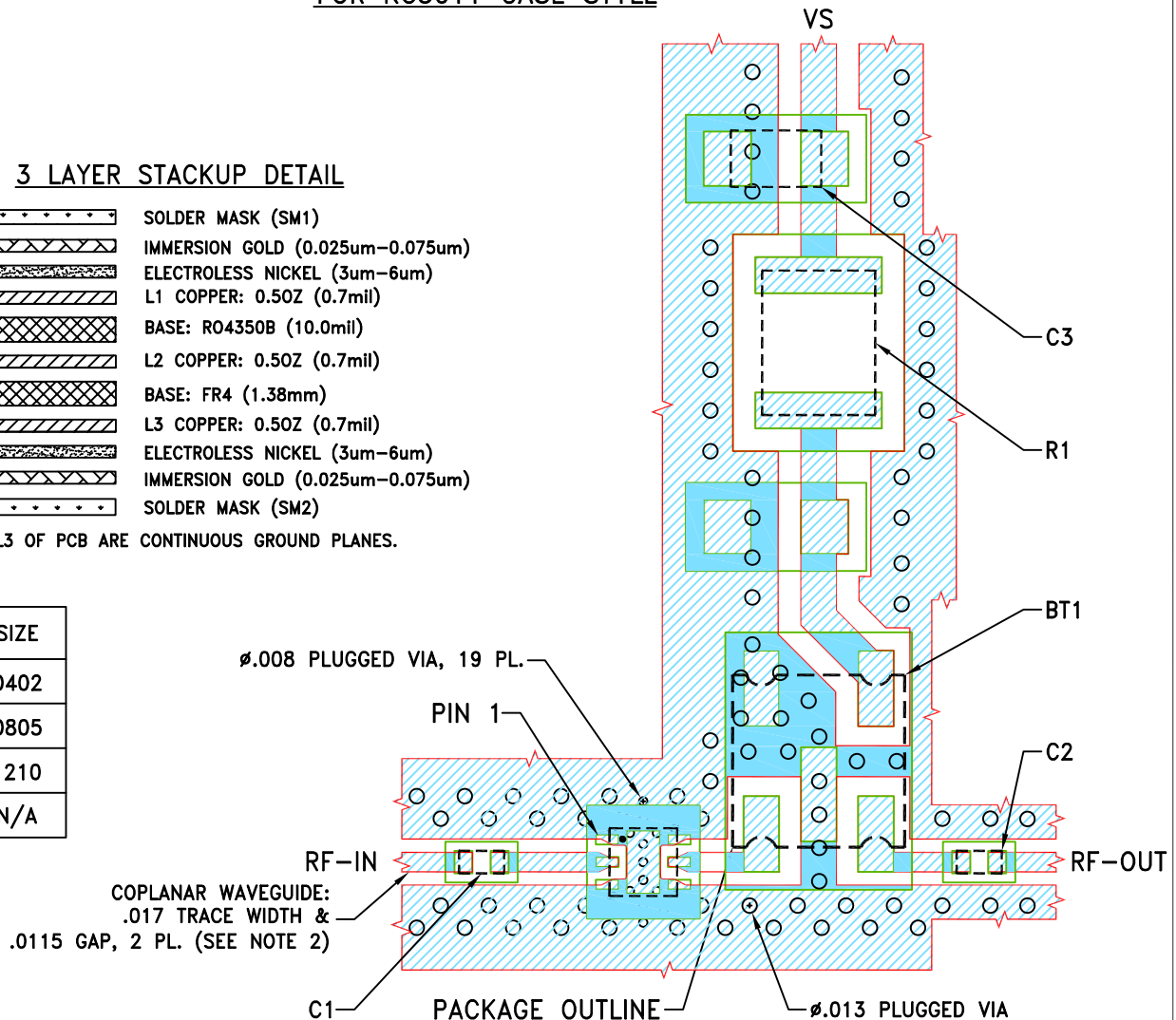

NOTES:

1. PCB IS MULTILAYER PCB, SEE STACK-UP DIAGRAM.
2. TRACE WIDTH & GAP ARE SHOWN FOR ROGERS R04350B WITH DIELECTRIC THICKNESS .010", COPPER: .5 OZ. EACH LAYER. FOR OTHER MATERIALS TRACE WIDTH & GAP MAY NEED TO BE MODIFIED.
3. CHIP COMPONENT FOOT PRINTS SHOWN FOR REFERENCE. FOR COMPONENT VALUES REFER TO TB-LEE1-XX+, WHERE XX=6, 39 & 63.



DENOTES PCB COPPER LAYOUT WITH SMOBC (SOLDER MASK OVER BARE COPPER).



DENOTES COPPER LAND PATTERN FREE OF SOLDER MASK.

UNLESS OTHERWISE SPECIFIED	INITIALS	DATE
DIMENSIONS ARE IN INCHES	ITG	02/09/26
TOLERANCES ON:	NP	02/09/26
2 PL DECIMALS ±	IL	02/09/26
3 PL DECIMALS ± .005		
ANGLES ±		
FRACTIONS ±		

Mini-Circuits®

THIS DOCUMENT AND ITS CONTENTS ARE THE PROPERTY OF MINI-CIRCUITS. EXCEPT FOR USE EXPRESSLY GRANTED, IN WRITING, TO ITS VENDORS, VENDEE AND THE UNITED STATES GOVERNMENT, MINI-CIRCUITS RESERVES ALL PROPRIETARY DESIGN, USE, MANUFACTURING AND REPRODUCTION RIGHTS THERETO. THESE CONTENTS SHALL NOT BE USED, DUPLICATED OR DISCLOSED TO ANY OUTSIDE PARTY, IN WHOLE OR IN PART, WITHOUT WRITTEN PERMISSION OF MINI-CIRCUITS.



Mini-Circuits®

13 Neptune Avenue
Brooklyn NY 11235

PL, KC3011, TB-LEE1-XXC+

SIZE	CODE IDENT	DRAWING NO:	REV:
A	15542	98-PL-851	OR
FILE:	98PL851	SCALE: 6:1	SHEET: 1 OF 1

Evaluation Board and Circuit

SEE DETAIL "A"

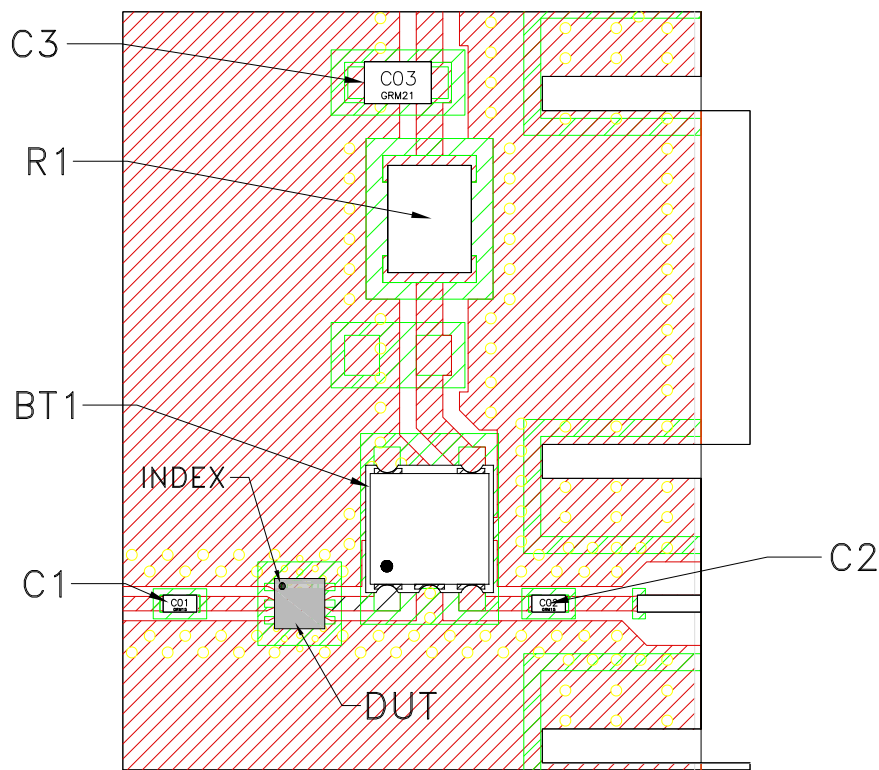
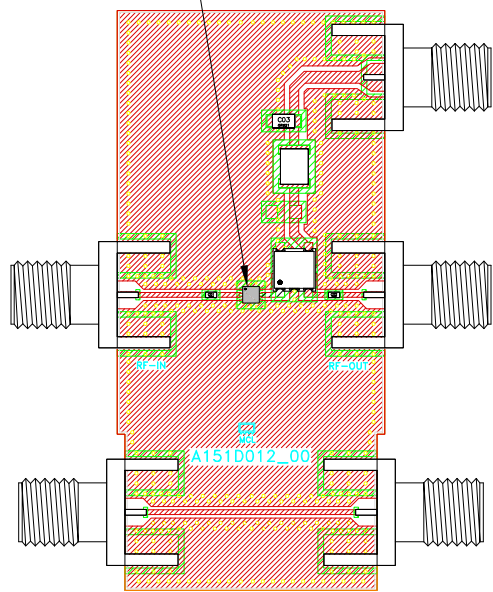

DETAIL "A"
LOCATION OF COMPONENTS
ON THE PCB
(SCALE 3:1)

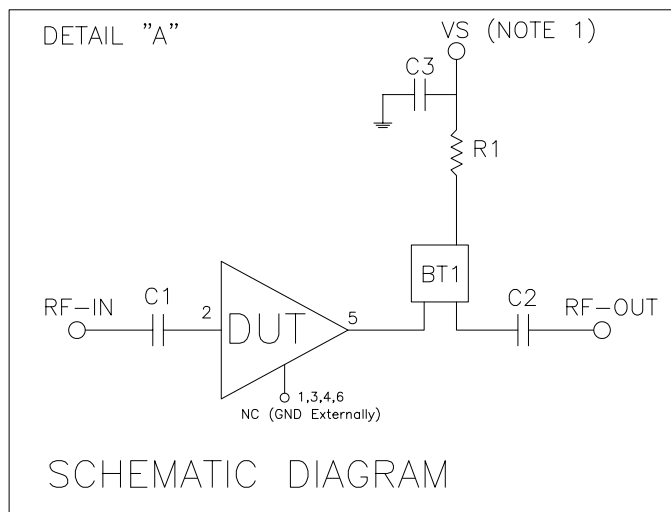

Components	Size	Value	Part Numbers	Manufacturer
C1,C2	0402	2.4nF	GRM1557U1A242JA1D	Murata
C3	0805	0.1uF	GCM21BR91H104KA37L	Murata
R1	1210	43Ω	RC1210FR-0743RL	Yageo
BT1	N/A	N/A	TCBT-14+	Mini Circuits

NOTES:

1. VS Voltage=+8V
2. 50 Ohm SMA Female Connectors.
3. PCB Material: Roger R04350B or equivalent,
Dielectric constant=3.5, Thickness=0.010 inch

Mini-Circuits®

All Mini-Circuits products are manufactured under exacting quality assurance and control standards, and are capable of meeting published specifications after being subjected to any or all of the following physical and environmental test.

Specification	Test/Inspection Condition	Reference/Spec
Operating Temperature	-40° to 85° C or -45° to 85° C or -55° to 105° C or -40° to 105° C or -40° to 95° C Ambient Environment	Individual Model Data Sheet
Storage Temperature	-55° to 100° C or -65° to 150° Ambient Environment	Individual Model Data Sheet
HTOL	1000 hours at 125°C	MIL-STD-883, Method 1005, Condition B
Thermal Shock	-55° to 100°C, 100 cycles	MIL-STD-202, Method 107, Condition A-3, except +100°C
Mechanical Shock	1.5Kg, 0.5 ms, 5 shock pulses, Y1 direction only	MIL-STD-883, Method 2002, Condition B, except Y1 direction only
Vibration (Variable Frequency)	50g peak	MIL-STD-883, Method 2007, Condition B
Autoclave	15 psig, 100% RH, 121°C, 96 hours	JESD22-A102, Condition C
HAST	130°C, 85% RH, 96 hours	JESD22-A110
Solderability	10X Magnification	J-STD-002, Para 4.2.5, Test S, 95% Coverage
Solder Reflow Heat	Sn-Pb Eutetic Process: 240°C peak Pb-Free Process: 260°C peak	J-STD-020, Table 4-1, 4-2 and 5-2; Figure 5-1
Moisture Sensitivity: Level 1	Bake at 125°C for 24 hours Soak at 85°C/85% RH for 168 hours, Reflow 3 cycles at 260°C peak	J-STD-020

All Mini-Circuits products are manufactured under exacting quality assurance and control standards, and are capable of meeting published specifications after being subjected to any or all of the following physical and environmental test.

Specification	Test/Inspection Condition	Reference/Spec
Marking Resistance to Solvents	Isopropyl alcohol + mineral spirits at 25°C; terpene defluxer at 25°C; distilled water + proylene glycol monomethyl ether + monoethanolamine at 63°C to 70°C	MIL-STD-202, Method 215