



LTCC SURFACE MOUNT

# Low Pass Filter

## LFCG-575+

50Ω DC to 575 MHz

### THE BIG DEAL

- Insertion Loss, Typ. 1.0 dB
- Stopband Rejection, Typ. 30 dB
- Passband Return Loss, Typ. 18 dB
- 0805 Surface Mount Footprint
- Power Handling: 3.5 Watts



Generic photo used for illustration purposes only

### APPLICATIONS

- Harmonic Rejection
- VHF/UHF Transmitters / Receivers
- RF Suppression for DC Lines on PCB
- Anti-Aliasing for A/D Converter

### FUNCTIONAL DIAGRAM

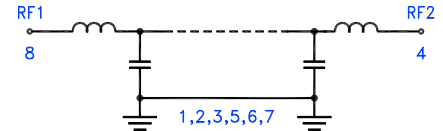

### PRODUCT OVERVIEW

Mini-Circuits' LFCG-575+ is a miniature low temperature co-fired ceramic (LTCC) low pass filter with a DC to 575 MHz passband supporting a variety of applications. This model provides 1.0 dB typical insertion loss over a wide band due to its rugged monolithic construction. Housed in an 0805 ceramic form factor which is ideal for dense signal chain PCB layouts where it complements MMIC size and performance. The LTCC fabrication process assures minimal RF performance variation while delivering a product that is well suited for environmental extremes of high humidity and temperature.

### KEY FEATURES

Features	Advantages
Ultra-wide Stopband	The LTCC lowpass filter provides a very good stopband rejection until 4400 MHz suitable for wide band applications.
LTCC Construction	Provides repeatable performance in a rugged, ceramic package well suited for tough environments such as high humidity and temperature extremes.
Small Size, 0805	Saves space in dense circuit board layouts and minimizes the effects of parasitics.
Rugged Power Handling, 3.5 Watts	Handles up to 3.5 Watts in a small 0805 package.



### ELECTRICAL SPECIFICATIONS<sup>1,2,3</sup> AT +25°C

Parameter	F#	Frequency (MHz)	Min.	Typ.	Max.	Units
Passband	Insertion Loss	DC-F1	—	1.0	1.9	dB
	Freq. Cut-Off <sup>4</sup>	Fc	—	3.0	—	dB
	Return Loss	DC-F1	DC - 575	—	18	—
Stopband	Rejection	F2-F3	25	30	—	dB
		F3-F4	—	25	—	dB

1. Tested in Evaluation Board P/NTB-LFCG-575+.

2. This filter is bi-directional, RF1 and RF2 ports may be interchanged. See S-Parameters for actual performance.

3. In applications where DC voltage and/or current is present at either the input or output ports, external DC blocking capacitors are required.

4. Typical variation ± 5%.

### ABSOLUTE MAXIMUM RATINGS<sup>5</sup>

Parameter	Ratings
Operating Temperature	-55°C to +125°C
Storage Temperature	-55°C to +125°C
Input Power <sup>6</sup>	3.5 W @ +25°C

5. Permanent damage may occur if any of these limits are exceeded.

6. Power rating applies only to signals within the passband. Power rating above +25°C operating temperature decreases linearly to 0.6 W at +125°C.

### TYPICAL FREQUENCY RESPONSE AT +25°C

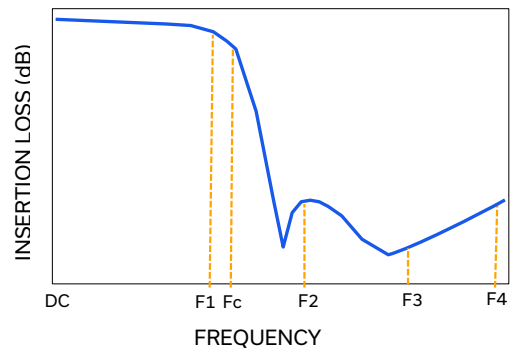



### TYPICAL PERFORMANCE GRAPHS

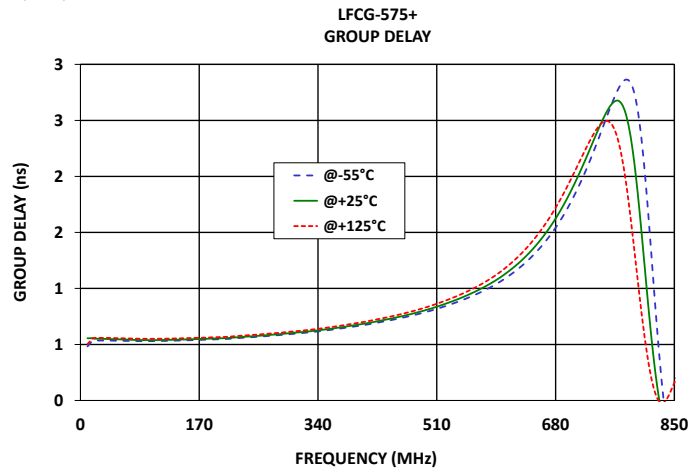
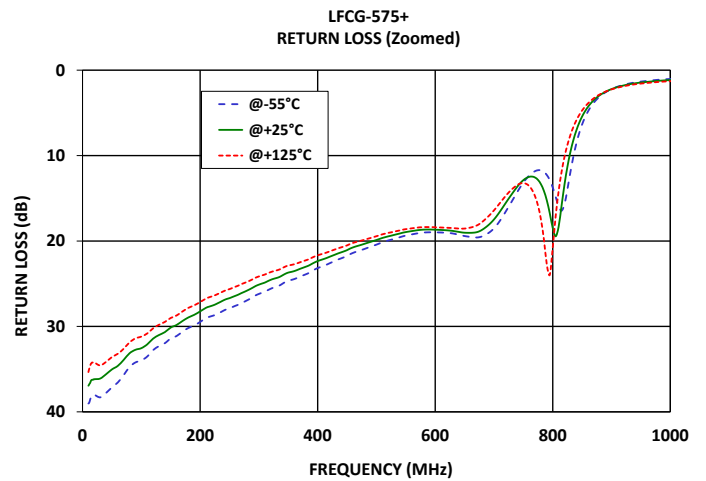
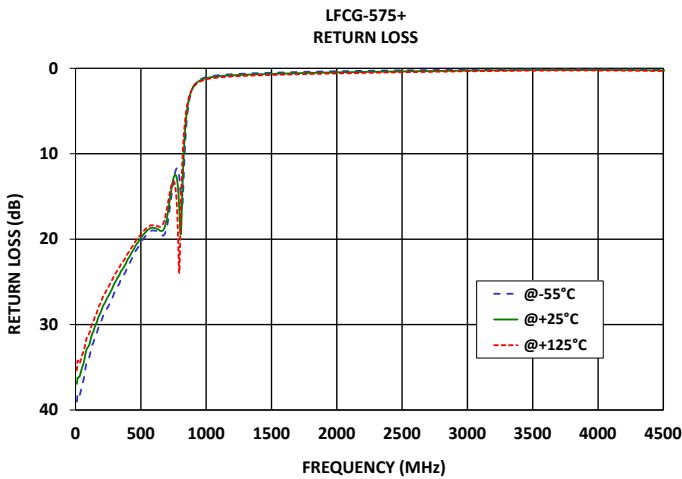
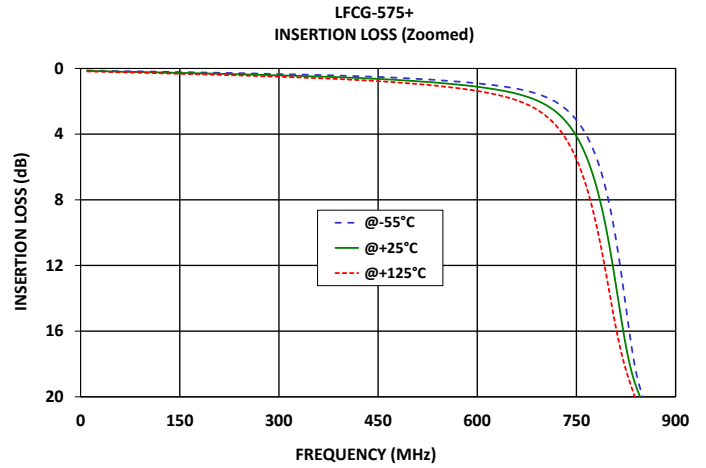
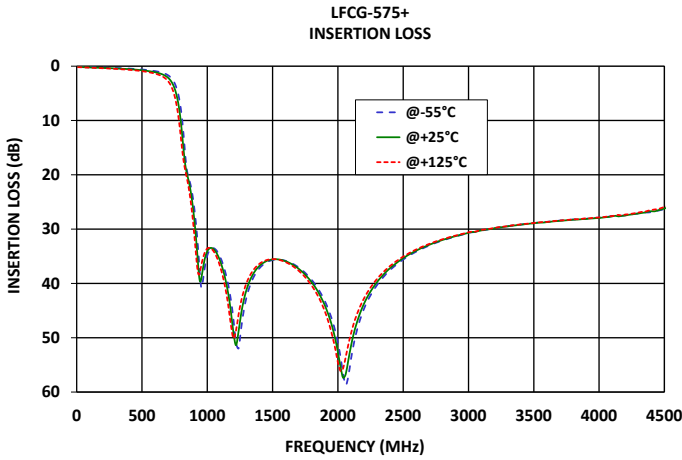



### FUNCTIONAL DIAGRAM

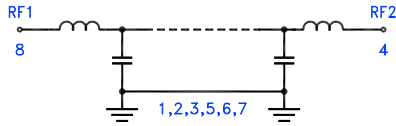
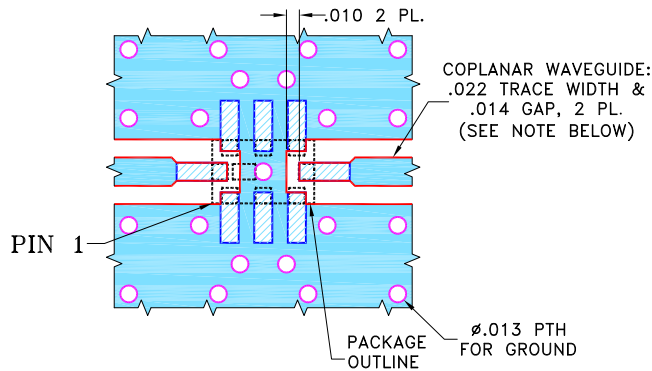

Figure 1. LFCG-575+ Functional Diagram

### PAD DESCRIPTION

Function	Pad Number	Description
RF1 <sup>2</sup>	8	Connects to RF Input Port
RF2 <sup>2</sup>	4	Connects to RF Output Port
GROUND	1,2,3,5,6,7	Connects to Ground on PCB, (See drawing PL-429)

### SUGGESTED PCB LAYOUT (PL-429)



NOTES:

1. COPLANAR WAVEGUIDE IS SHOWN FOR ROGERS R04350B WITH DIELECTRIC THICKNESS .010" ± .001". COPPER: 1/2 OZ. EACH SIDE. FOR OTHER MATERIALS TRACE WIDTH AND GAP MAY NEED TO BE MODIFIED.
2. BOTTOM SIDE OF THE PCB IS CONTINUOUS GROUND PLANE.

- DENOTES PCB COPPER LAYOUT WITH SMOBC (SOLDER MASK OVER BARE COPPER).
- DENOTES COPPER LAND PATTERN FREE OF SOLDER MASK.

Figure 2. Suggested PCB Layout PL-429

### CASE STYLE DRAWING

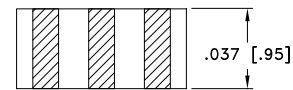
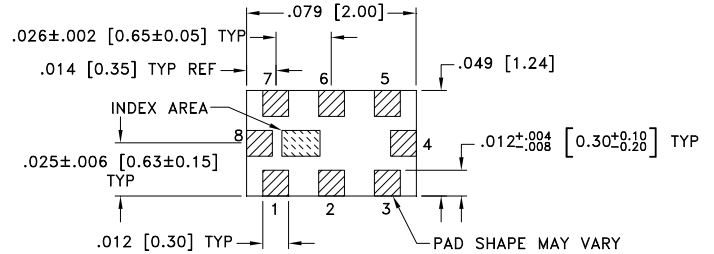

Weight: .008 grams

Dimensions are in inches (mm). Tolerances: 2Pl. ± .01; 3 Pl. ± .005

### PRODUCT MARKING\*: KS

\*Marking may contain other features or characters for internal lot control.



LTCC SURFACE MOUNT

# Low Pass Filter

## LFCG-575+

Mini-Circuits

50Ω DC to 575 MHz

ADDITIONAL DETAILED INFORMATION IS AVAILABLE ON OUR DASHBOARD.

[CLICK HERE](#)

Performance Data and Graphs	Data
	Graphs
	S-Parameter (S2P Files) Data Set (.zip file) De-embedded to device pads
Case Style	GE0805C-2    Lead Finish: Tin over Nickel plating
RoHS Status	Compliant
Tape and Reel	F114
Suggested Layout for PCB Design	PL-429
Evaluation Board	TB-LFCG-575+
	Gerber File
Environmental Rating	ENV06

### NOTES

- A. Performance and quality attributes and conditions not expressly stated in this specification document are intended to be excluded and do not form a part of this specification document.
- B. Electrical specifications and performance data contained in this specification document are based on Mini-Circuits' applicable established test performance criteria and measurement instructions.
- C. The parts covered by this specification document are subject to Mini-Circuits' standard limited warranty and terms and conditions (collectively, "Standard Terms"); Purchasers of this part are entitled to the rights and benefits contained therein. For a full statement of the standard terms and the exclusive rights and remedies thereunder, please visit Mini-Circuits' website at [www.minicircuits.com/terms/viewterm.html](http://www.minicircuits.com/terms/viewterm.html)



Typical Performance Data

FREQ.  (MHz)	INSERTION LOSS			INPUT RETURN LOSS			OUTPUT RETURN LOSS		
	(dB)			(dB)			(dB)		
	@-55°C	@+25°C	@+125°C	@-55°C	@+25°C	@+125°C	@-55°C	@+25°C	@+125°C
10	0.12	0.14	0.18	39.03	36.94	35.35	39.86	37.57	35.82
50	0.16	0.18	0.22	37.13	35.03	33.59	36.99	35.12	33.62
100	0.19	0.23	0.27	33.99	32.55	31.19	35.03	33.57	32.21
150	0.22	0.27	0.33	31.42	30.14	29.01	33.99	32.56	31.19
200	0.26	0.32	0.38	29.48	28.24	27.16	34.04	32.26	30.66
250	0.30	0.36	0.44	27.88	26.69	25.64	34.82	32.56	30.65
300	0.34	0.42	0.50	26.20	25.11	24.15	36.29	33.82	31.61
350	0.39	0.48	0.58	24.64	23.70	22.87	36.97	35.77	33.77
400	0.45	0.55	0.67	23.17	22.35	21.68	33.85	34.94	35.65
450	0.52	0.64	0.78	21.75	21.07	20.52	29.42	30.57	32.05
500	0.61	0.75	0.92	20.43	19.88	19.44	25.79	26.55	27.48
520	0.66	0.81	0.98	19.94	19.46	19.05	24.75	25.41	26.19
575	0.82	1.00	1.22	19.05	18.70	18.39	22.67	23.20	23.77
600	0.91	1.11	1.37	18.99	18.68	18.39	22.30	22.86	23.47
635	1.08	1.33	1.65	19.19	18.88	18.52	22.88	23.57	24.28
685	1.48	1.86	2.38	19.29	18.45	17.47	24.57	23.68	22.12
725	2.20	2.85	3.76	15.98	15.04	14.33	16.99	15.37	13.77
800	8.32	10.84	13.67	13.74	18.48	20.76	5.05	4.60	4.32
850	19.90	20.37	21.37	6.35	5.42	4.72	2.14	2.25	2.40
900	26.08	28.15	30.90	2.21	2.22	2.25	1.33	1.47	1.65
910	28.22	30.65	33.65	1.94	1.99	2.05	1.23	1.38	1.55
950	40.15	39.56	37.17	1.34	1.45	1.57	0.96	1.10	1.26
1000	34.86	34.08	33.58	1.03	1.16	1.29	0.74	0.86	1.00
1020	33.78	33.51	33.46	0.96	1.09	1.23	0.67	0.79	0.92
1200	46.52	49.02	50.11	0.69	0.81	0.94	0.37	0.45	0.54
1500	35.70	35.58	35.53	0.52	0.65	0.78	0.22	0.28	0.35
1700	37.07	37.31	37.67	0.44	0.57	0.70	0.18	0.23	0.29
1800	39.36	39.80	40.42	0.40	0.53	0.66	0.16	0.21	0.26
1900	43.26	44.03	45.12	0.36	0.50	0.62	0.15	0.21	0.26
2000	50.94	52.62	54.53	0.34	0.47	0.60	0.15	0.20	0.25
2100	53.98	51.57	49.25	0.32	0.45	0.57	0.14	0.19	0.23
2200	44.67	43.74	42.76	0.29	0.42	0.54	0.13	0.19	0.23
2300	40.29	39.74	39.17	0.28	0.40	0.52	0.13	0.19	0.23
2400	37.53	37.17	36.78	0.26	0.38	0.49	0.12	0.17	0.21
2500	35.60	35.34	35.06	0.24	0.36	0.46	0.12	0.17	0.22
2600	34.15	33.96	33.74	0.22	0.34	0.44	0.11	0.17	0.22
2700	33.01	32.88	32.72	0.21	0.32	0.42	0.11	0.17	0.22
2800	32.09	32.00	31.88	0.19	0.30	0.39	0.11	0.17	0.22
2900	31.36	31.30	31.20	0.18	0.29	0.37	0.10	0.16	0.22
3000	30.72	30.68	30.59	0.16	0.26	0.35	0.09	0.16	0.21
3050	30.53	30.51	30.47	0.17	0.27	0.35	0.09	0.16	0.22
3100	30.25	30.23	30.15	0.15	0.25	0.32	0.09	0.16	0.22
3150	30.06	30.04	29.99	0.15	0.25	0.33	0.09	0.16	0.22
3200	29.83	29.83	29.77	0.14	0.24	0.31	0.09	0.16	0.22
3250	29.66	29.66	29.60	0.14	0.24	0.31	0.08	0.15	0.22
3300	29.48	29.49	29.44	0.14	0.24	0.30	0.07	0.15	0.22
3350	29.32	29.34	29.26	0.13	0.23	0.29	0.07	0.15	0.22
3400	29.16	29.18	29.12	0.12	0.21	0.28	0.07	0.15	0.22
3450	29.02	29.04	29.00	0.12	0.21	0.27	0.07	0.14	0.22
3500	28.90	28.92	28.87	0.12	0.22	0.28	0.07	0.15	0.22
3550	28.78	28.80	28.74	0.12	0.21	0.27	0.06	0.14	0.22
3600	28.67	28.71	28.68	0.12	0.21	0.27	0.06	0.14	0.22
3700	28.42	28.47	28.42	0.11	0.20	0.25	0.05	0.14	0.23
3800	28.23	28.27	28.22	0.12	0.21	0.26	0.05	0.15	0.24
3900	28.11	28.13	28.01	0.11	0.20	0.25	0.05	0.15	0.25
4000	27.89	27.94	27.85	0.12	0.21	0.26	0.05	0.15	0.25
4100	27.61	27.65	27.60	0.12	0.21	0.26	0.05	0.15	0.26
4200	27.46	27.50	27.31	0.13	0.22	0.28	0.04	0.15	0.28
4300	27.13	27.13	26.96	0.13	0.22	0.28	0.04	0.15	0.28
4400	26.87	26.70	26.50	0.15	0.24	0.30	0.05	0.17	0.30

## Typical Performance Data

FREQ.  (MHz)	GROUP DELAY		
	(nsec)		
	@-55°C	@+25°C	@+125°C
10	0.48	0.56	0.50
15	0.52	0.56	0.54
20	0.54	0.55	0.56
30	0.54	0.55	0.56
40	0.53	0.55	0.56
50	0.53	0.55	0.56
60	0.53	0.54	0.56
70	0.53	0.54	0.55
80	0.53	0.54	0.55
90	0.53	0.54	0.55
100	0.53	0.54	0.55
110	0.53	0.54	0.55
120	0.53	0.54	0.55
130	0.53	0.54	0.55
140	0.53	0.54	0.55
150	0.54	0.54	0.56
160	0.54	0.55	0.56
170	0.54	0.55	0.56
180	0.54	0.55	0.56
190	0.54	0.55	0.56
200	0.55	0.55	0.57
210	0.55	0.56	0.57
220	0.55	0.56	0.57
230	0.56	0.57	0.58
240	0.56	0.57	0.58
250	0.57	0.57	0.59
260	0.57	0.58	0.59
270	0.58	0.58	0.60
280	0.58	0.59	0.60
290	0.59	0.59	0.61
300	0.59	0.60	0.61
310	0.60	0.61	0.62
320	0.60	0.61	0.63
330	0.61	0.62	0.63
340	0.62	0.63	0.64
350	0.62	0.63	0.65
400	0.67	0.68	0.70
450	0.72	0.74	0.76
500	0.80	0.82	0.84
550	0.90	0.93	0.96
575	0.97	1.00	1.04

## Typical Performance Curves

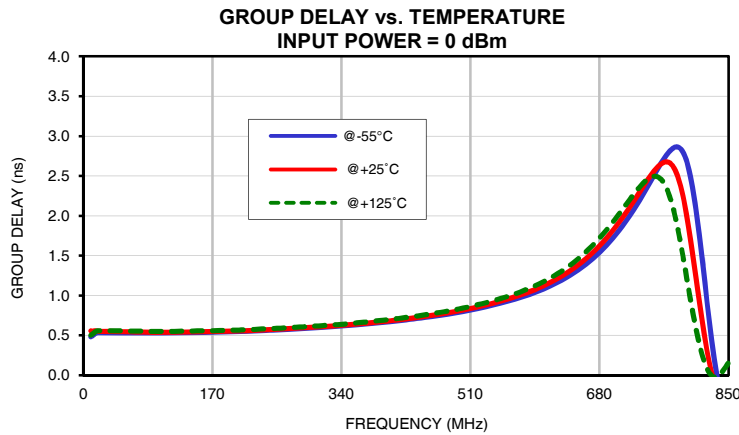
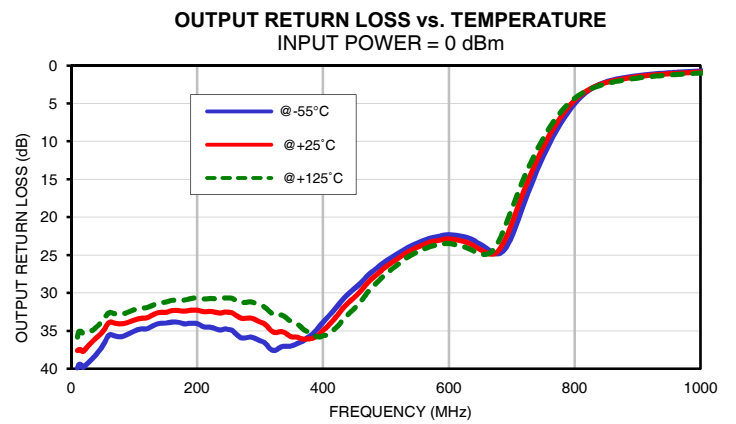
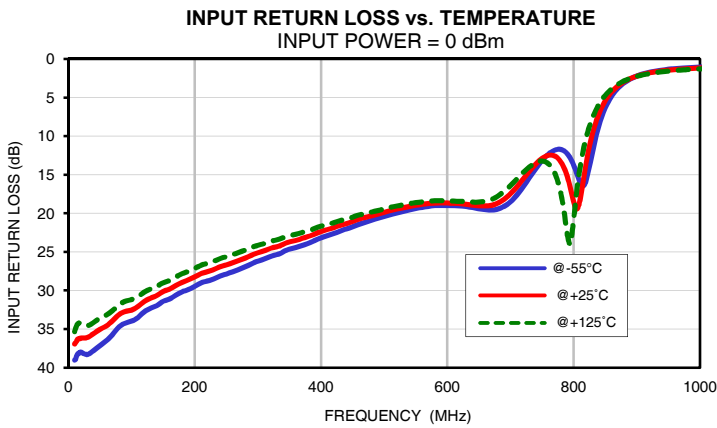
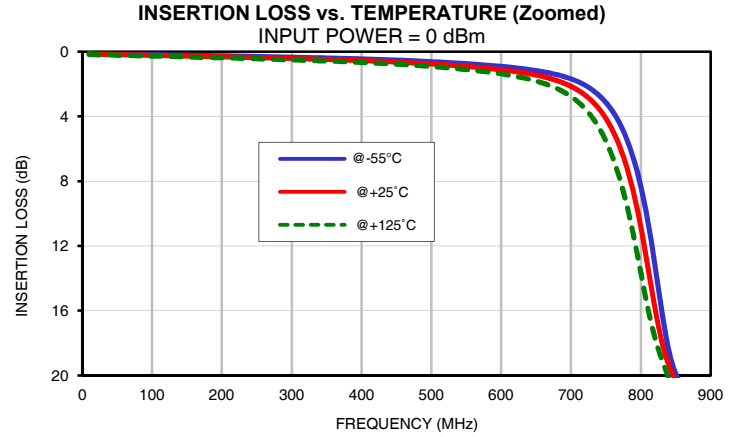
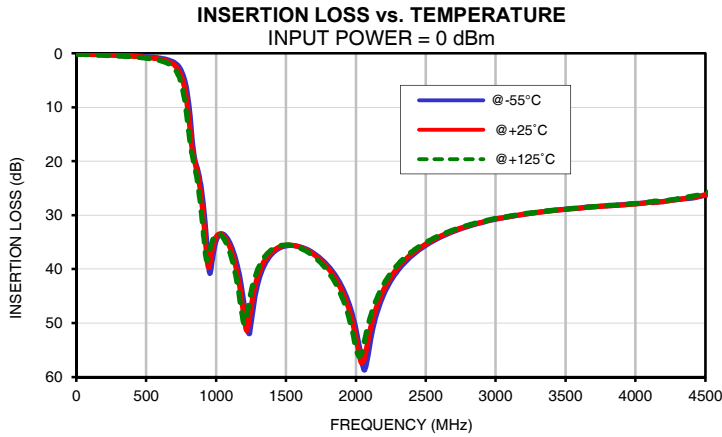

### Outline Dimensions

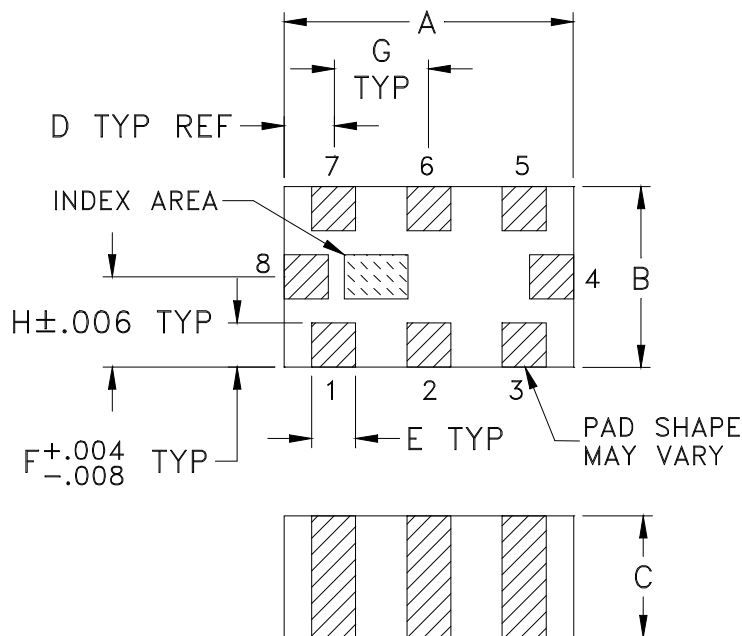

### PCB Land Pattern

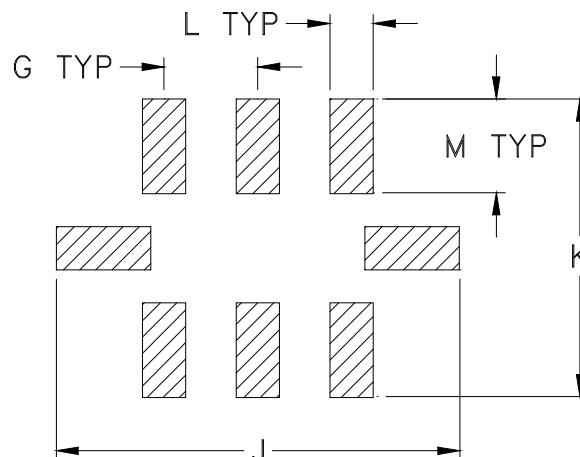

Suggested Layout,  
Tolerance to be within  $\pm .002$

CASE #	A	B	C	D	E	F	G	H	J	K	L
GE0805C-2	.079 (2.00)	.049 (1.25)	.037 (0.95)	.014 (0.35)	.012 (0.30)	.012 (0.30)	.026 (0.65)	.025 (0.63)	.134 (3.40)	.110 (2.80)	.014 (0.35)

CASE #	M	WT. GRAM
GE0805C-2	.039 (1.00)	.008

Dimensions are in inches (mm). Tolerances: 2Pl.  $\pm .01$ ; 3 Pl.  $\pm .005$

#### Notes:

- Open style, ceramic base.
- Termination finish: For RoHS Case Styles: Tin plate over Nickel plate. All models, (+) suffix.  
For RoHS-5 Case Styles: Tin-Lead plate over Nickel plate. All models, no (+) suffix.
- Pad tolerance to be non-cumulative. Minimum spacing between each pad is .004 (0.1).



P.O. Box 350166, Brooklyn, New York 11235-0003 (718) 934-4500 Fax (718) 332-4661 For detailed performance specs & shopping online see Mini-Circuits web site



The Design Engineers Search Engine Provides ACTUAL Data Instantly From MINI-CIRCUITS At: [www.minicircuits.com](http://www.minicircuits.com)

RF/IF MICROWAVE COMPONENTS

# Tape & Reel Packaging TR-F114

## DEVICE ORIENTATION IN T&R



ILLUSTRATION 1

Applicable Case Styles	
GE0805C	JC0603C
GE0805C-1	JC0603C-4
GE0805C-1AP	JC0603C-6
GE0805C-7	
GE0805C-9	
GE0805C-10	
GE0805C-11	
GE0805C-12	

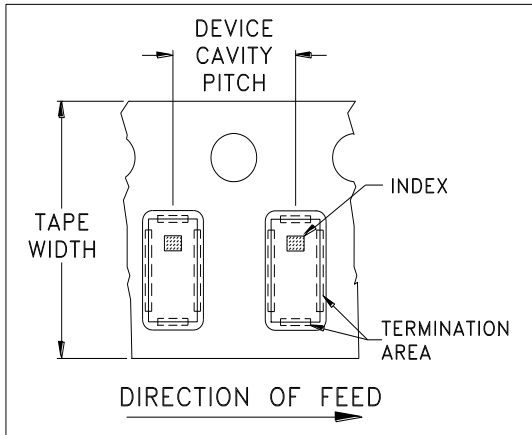

ILLUSTRATION 2

Applicable Case Styles	
GE0805C-2	JC0603C-1
GE0805C-3	JC0603C-2
GE0805C-4	JC0603C-3
GE0805C-5	JC0603C-5
GE0805C-6	JC0603C-7
GE0805C-8	
GE0805C-15	

Tape Width, mm	Device Cavity Pitch, mm	Reel Size, inches	Devices per Reel	
8	4	7	Small quantity standards (see note)	20
				50
				100
				200
				500
				1000
			Standard	4000

Note: Please Consult individual model data sheet to determine device per reel availability.

Mini-Circuits carrier tape materials provide protection from ESD (Electro-Static Discharge) during handling and transportation. Tapes are static dissipative and comply with industry standards EIA-481/EIA-541.

Go to: [www.minicircuits.com/pages/pdfs/tape.pdf](http://www.minicircuits.com/pages/pdfs/tape.pdf)



INTERNET <http://www.minicircuits.com>

P.O. Box 350166, Brooklyn, New York 11235-0003 (718) 934-4500 Fax (718) 332-4661

Distribution Centers NORTH AMERICA 800-654-7949 • 417-335-5935 • Fax 417-335-5945 • EUROPE 44-1252-832600 • Fax 44-1252-837010

Mini-Circuits ISO 9001 & ISO 14001 Certified

THIRD ANGLE PROJECTION

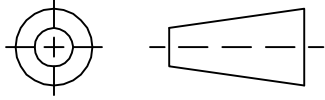

REVISIONS

REV	ECN No.	DESCRIPTION	DATE	DR	AUTH
OR	M148457	NEW RELEASE	10/14/14	GF	MY

SUGGESTED MOUNTING CONFIGURATION  
FOR GE0805C-4 CASE STYLE, "08FL07" PIN CODE

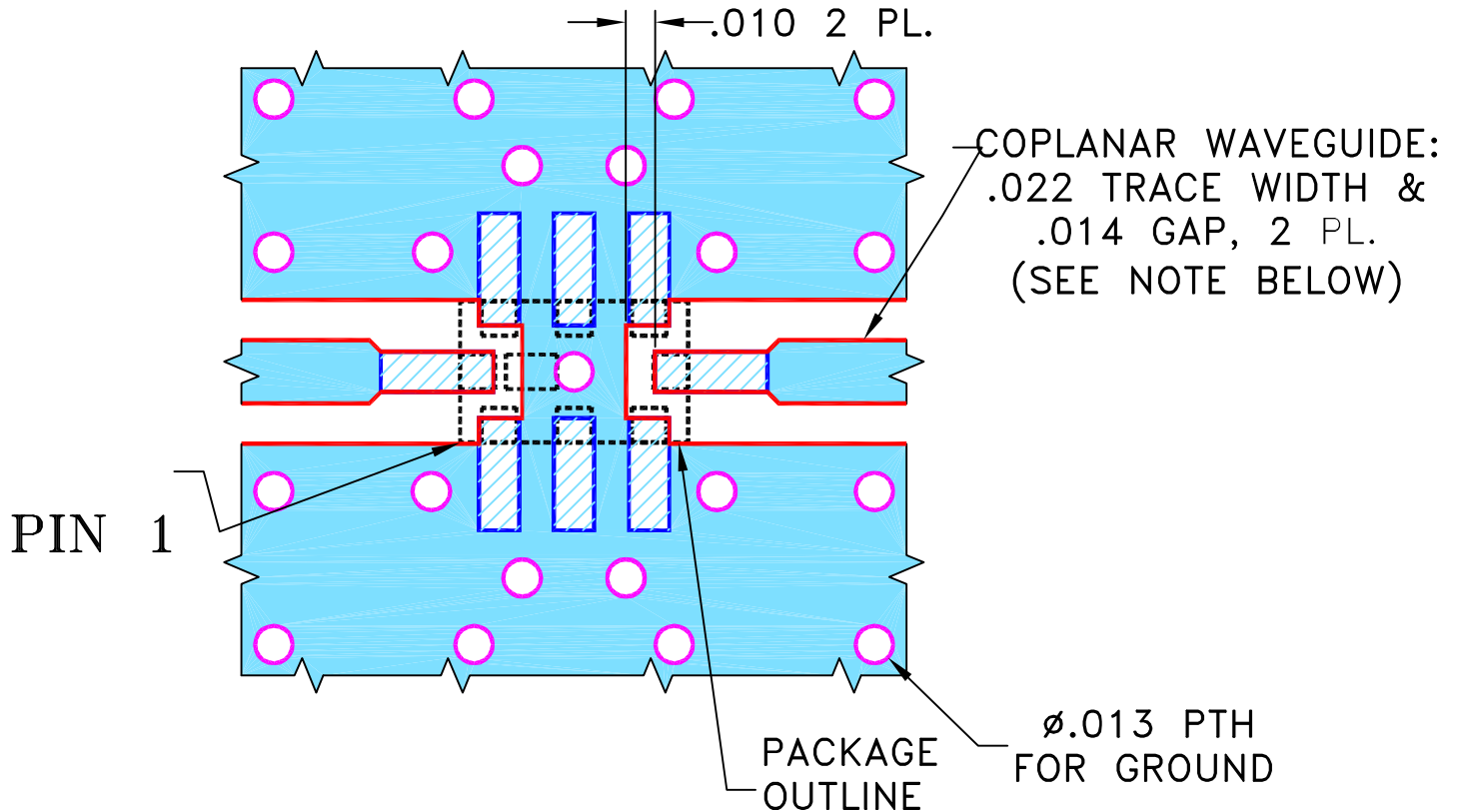

NOTES:

1. COPLANAR WAVEGUIDE IS SHOWN FOR ROGERS R04350B WITH DIELECTRIC THICKNESS .010" ± .001". COPPER: 1/2 OZ. EACH SIDE. FOR OTHER MATERIALS TRACE WIDTH AND GAP MAY NEED TO BE MODIFIED.
2. BOTTOM SIDE OF THE PCB IS CONTINUOUS GROUND PLANE.



DENOTES PCB COPPER LAYOUT WITH SMOBC (SOLDER MASK OVER BARE COPPER).



DENOTES COPPER LAND PATTERN FREE OF SOLDER MASK.

UNLESS OTHERWISE SPECIFIED	INITIALS	DATE
DIMENSIONS ARE IN INCHES	DRAWN GF	10/01/14
TOLERANCES ON:	CHECKED IL	10/14/14
2 PL DECIMALS ±	APPROVED MY	10/14/14
3 PL DECIMALS ± .005		
ANGLES ±		
FRACTIONS ±		

 **Mini-Circuits<sup>®</sup>** 13 Neptune Avenue  
Brooklyn NY 11235

PL, 08FL07, GE0805C-4, TB-799+

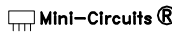
 Mini-Circuits<sup>®</sup>  
THIS DOCUMENT AND ITS CONTENTS ARE THE PROPERTY OF MINI-CIRCUITS. EXCEPT FOR USE EXPRESSLY GRANTED, IN WRITING, TO ITS VENDORS, VENDEE AND THE UNITED STATES GOVERNMENT, MINI-CIRCUITS RESERVES ALL PROPRIETARY DESIGN, USE, MANUFACTURING AND REPRODUCTION RIGHTS THERETO. THESE CONTENTS SHALL NOT BE USED, DUPLICATED OR DISCLOSED TO ANY OUTSIDE PARTY, IN WHOLE OR IN PART, WITHOUT WRITTEN PERMISSION OF MINI-CIRCUITS.

ASHEETA1.DWG REV:A DATE:01/12/95

SIZE	CODE IDENT	DRAWING NO:	REV:
A	15542	98-PL-429	OR
FILE:	98PL429	SCALE: 15:1	SHEET: 1 OF 1

# Evaluation Board and Circuit

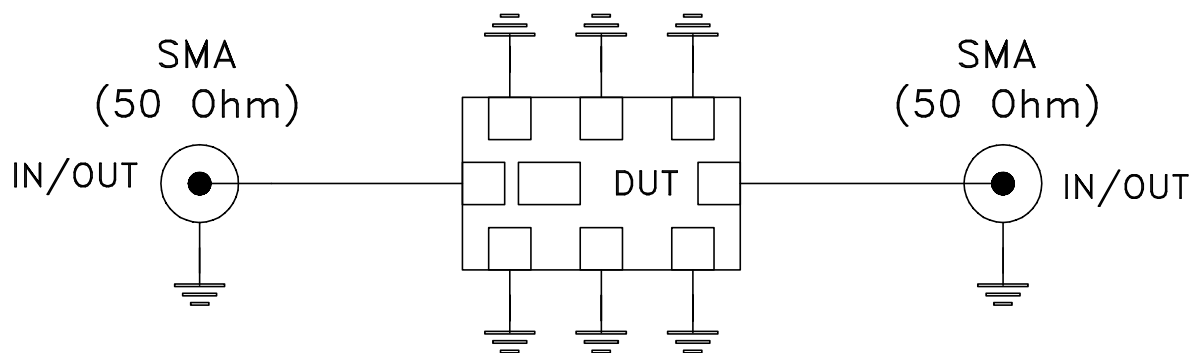
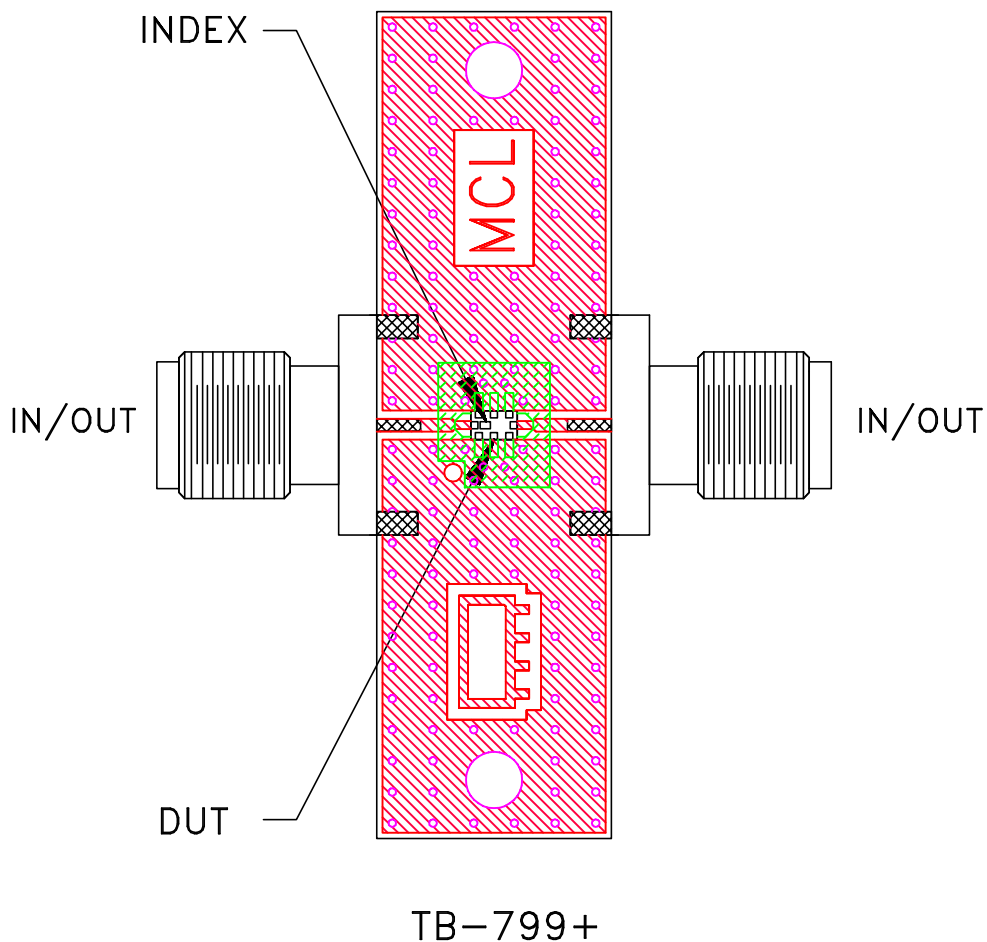

Schematic Diagram

**Notes:**

1. 50 Ohm SMA Female connectors.
2. PCB Material: R04350 or equivalent,  
Dielectric Constant=3.5, Thickness=.010 inch.

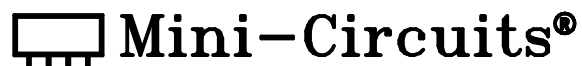

All Mini-Circuits products are manufactured under exacting quality assurance and control standards, and are capable of meeting published specifications after being subjected to any or all of the following physical and environmental test.

Specification	Test/Inspection Condition	Reference/Spec
Operating Temperature	-55° to 100°C Ambient Environment	Individual Model Data Sheet
Storage Temperature	-55° to 100° C Ambient Environment	Individual Model Data Sheet
Humidity	90 to 95% RH, 240 hours, 50°C	MIL-STD-202, Method 103, Condition A, Except 50°C and end-point electrical test done within 12 hours
Solder Reflow Heat	Sn-Pb Eutetic Process: 225°C peak Pb-Free Process 245° - 250°C peak	J-STD-020, Table 4-1, 4-2 and 5-2, Figure 5-1
Solderability	10X Magnification	J-STD-002, Para 4.2.5, Test S, 95% Coverage
Vibration (High Frequency)	20g peak, 10-2000 Hz, 12 times in each of three perpendicular directions (total 36)	MIL-STD-202, Method 204, Condition D
Mechanical Shock	50g, 11 ms, 1/2-sine, 18 shocks: 3 each direction, each of 3 axes	MIL-STD-202, Method 213, Condition A