

# Ceramic Low Pass Filter

## LFCN-2290-2+

50Ω DC to 2290 MHz

### The Big Deal

- Rugged, ceramic construction
- Tiny size, 0.12 x 0.06 x 0.04"
- Excellent power handling, 10W

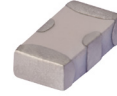

CASE STYLE: FV1206

### Product Overview

Mini-Circuits' LFCN-2290-2+ is an LTCC low pass filter with a passband from DC to 2290 MHz, supporting a variety of applications. This model provides 0.9 dB passband insertion loss, 29 dB stopband rejection from 3110 to 3500 MHz, and 40 dB rejection from 3500 to 8000 MHz. It handles up to 10W RF input power and provides a wide operating temperature range from -55 to +100°C. Housed in a tiny 1206 ceramic form factor with wraparound terminations, the filter is ideal for dense PCB layouts and with minimal performance variation due to parasitics.

### Key Features

Feature	Advantages
LTCC Construction	Provides repeatable performance in a rugged, ceramic package well suited for tough environments such as high humidity and temperature extremes.
Tiny size (0.12 x 0.06 x 0.04")	Saves space in dense circuit board layouts and minimizes the effects of parasitics.
High power handling, 10W	Supports a wide range of system power requirements.
Wrap-around terminations	Provides excellent solderability and easy visual inspection
Wide operating temperature range, -55 to +100°C	Enables reliable performance in extreme environments.



Ceramic

# Low Pass Filter

50Ω

DC<sup>(1)</sup> to 2290 MHz

## LFCN-2290-2+

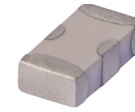

Generic photo used for illustration purposes only  
CASE STYLE: FV1206

### Features

- excellent power handling, 10W
- small size
- 7 sections
- temperature stable
- LTCC construction
- protected by U.S Patent 6,943,646

### Applications

- harmonic rejection
- transmitters/receivers
- lab use

**+RoHS Compliant**  
The +Suffix identifies RoHS Compliance. See our web site for RoHS Compliance methodologies and qualifications

Available Tape and Reel at no extra cost	
Reel Size	Devices/Reel
7"	20, 50, 100, 200, 500, 1000, 3000

### Electrical Specifications<sup>(1,2)</sup> at 25°C

Parameter	F#	Frequency (MHz)	Min.	Typ.	Max.	Unit	
Pass Band	Insertion Loss	DC-F1	DC-2290	—	0.9	1.5	dB
	Freq. Cut-Off	F2	2590	—	3.0	—	dB
	VSWR	DC-F1	DC-2290	—	1.3	—	:1
Stop Band	Rejection Loss	F3-F5	3110-8000	20	29	—	dB
		F4-F5	3500-8000	26	40	—	dB
	VSWR	F3-F5	3110-8000	—	25	—	:1

(1) In Application where DC voltage is present at either input or output ports, coupling capacitors are required.  
(2) Measured on Mini-Circuits Characterization Test Board TB-270.

### Maximum Ratings

Operating Temperature	-55°C to +100°C
Storage Temperature	-55°C to +100°C
RF Power Input*	10W at 25°C

\*Passband rating, derate linearly to 3.5W at 100°C ambient  
Permanent damage may occur if any of these limits are exceeded.

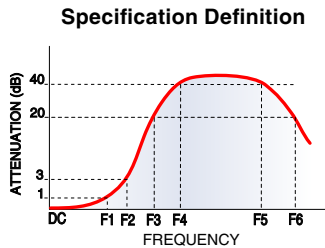

### Functional Schematic

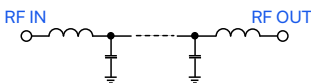

### Top View

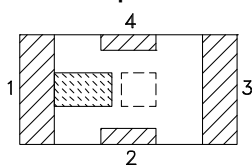

### Pad Connections

Input	1
Output	3
Ground	2,4

PRODUCT MARKING: G4

### Typical Performance Data at 25°C

Frequency (MHz)	Insertion Loss (dB)	VSWR (:1)
1	0.10	1.02
10	0.14	1.01
100	0.22	1.03
500	0.31	1.06
900	0.39	1.15
2000	0.82	1.37
2400	1.30	1.38
2600	3.56	2.74
3200	28.72	25.70
3600	55.21	27.88
4600	52.08	5.64
5000	49.40	30.52
6000	40.18	71.73
6600	36.50	45.00
7000	33.88	35.53
7600	33.99	23.55
8000	33.69	18.81

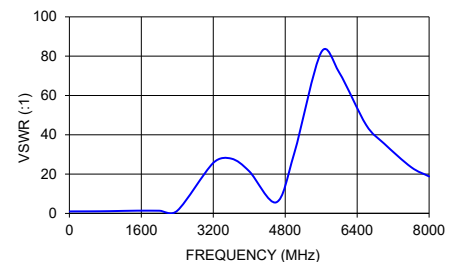
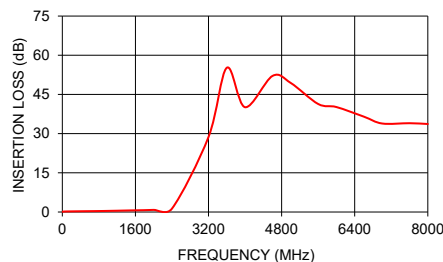

## Outline Drawing

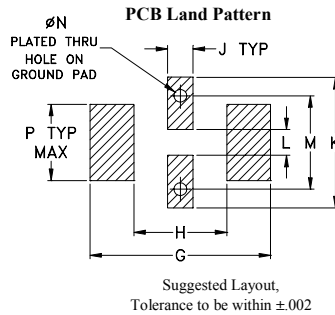
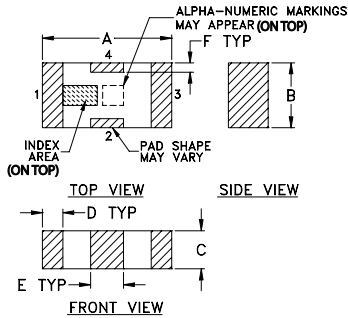

## Demo Board MCL P/N: TB-270 Suggested PCB Layout (PL-137)

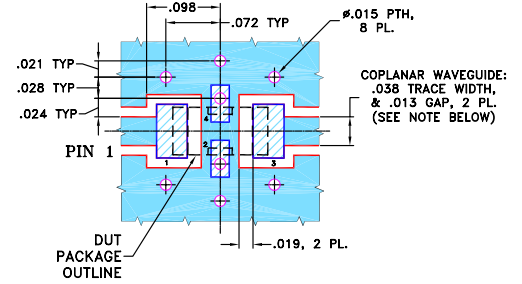

- NOTES:**
1. COPLANAR WAVEGUIDE PARAMETERS ARE SHOWN FOR ROGERS RO4350B WITH THICKNESS  $.020" \pm .0015"$ . COPPER: 1/2 OZ. EACH SIDE. FOR OTHER MATERIALS TRACE WIDTH & GAP MAY NEED TO BE MODIFIED.
  2. BOTTOM SIDE OF THE PCB IS CONTINUOUS GROUND PLANE.
- DENOTES PCB COPPER LAYOUT WITH SMOBC (SOLDER MASK OVER BARE COPPER)
  - DENOTES COPPER LAND PATTERN FREE OF SOLDER MASK

## Pad Connections

Input	1
Output	3
Ground	2,4

## Outline Dimensions (Inch/mm)

A	B	C	D	E	F	G	
.126	.063	.037	.020	.032	.009	.169	
3.20	1.60	0.94	0.51	0.81	0.23	4.29	
H	J	K	L	M	N	P	wt
.087	.024	.122	.024	.087	.012	.071	grams
2.21	0.61	3.10	0.61	2.21	0.30	1.80	.020

## Additional Notes

- Performance and quality attributes and conditions not expressly stated in this specification document are intended to be excluded and do not form a part of this specification document.
- Electrical specifications and performance data contained in this specification document are based on Mini-Circuit's applicable established test performance criteria and measurement instructions.
- The parts covered by this specification document are subject to Mini-Circuits standard limited warranty and terms and conditions (collectively, "Standard Terms"); Purchasers of this part are entitled to the rights and benefits contained therein. For a full statement of the Standard Terms and the exclusive rights and remedies thereunder, please visit Mini-Circuits' website at [www.minicircuits.com/MCLStore/terms.jsp](http://www.minicircuits.com/MCLStore/terms.jsp)

*Typical Performance Data*

FREQUENCY (MHz)	INSERTION LOSS (dB)	INPUT RETURN LOSS (dB)
1	0.10	42.33
4	0.13	46.78
7	0.13	44.73
10	0.14	43.26
40	0.18	40.66
70	0.20	37.31
100	0.22	36.21
300	0.27	32.89
500	0.31	31.02
700	0.35	27.17
900	0.39	22.96
1100	0.45	19.71
1120	0.46	19.49
1140	0.47	19.25
1160	0.48	18.96
1180	0.49	18.64
1200	0.49	18.33
1220	0.50	18.06
1228	0.50	17.96
1230	0.50	17.93
1250	0.51	17.70
1270	0.52	17.45
1290	0.53	17.23
1310	0.54	17.02
1330	0.54	16.86
1350	0.55	16.74
1370	0.56	16.57
1390	0.57	16.36
1410	0.58	16.18
1430	0.59	15.99
1450	0.59	15.85
1470	0.60	15.75
1490	0.61	15.67
1510	0.62	15.58
1530	0.63	15.53
1550	0.63	15.45
1570	0.64	15.35
1575	0.64	15.33
1580	0.65	15.31
1600	0.65	15.25
1620	0.66	15.21
1640	0.67	15.18
1660	0.67	15.14
1680	0.68	15.11
1700	0.69	15.08
1800	0.72	15.24
2000	0.82	16.07
2200	0.96	17.52
2400	1.30	16.02
2600	3.56	6.66
2800	21.47	1.15
3000	26.27	0.76
3200	28.72	0.68
3400	36.10	0.64
3600	55.21	0.62
3800	44.05	0.69
4000	40.11	0.81
4200	39.21	1.28
4400	40.87	3.14
4600	52.08	3.11
4800	52.33	1.15
5000	49.40	0.57
5200	45.91	0.38
5400	43.29	0.29
5600	41.35	0.21
5800	40.13	0.26
6000	40.18	0.24
6200	39.48	0.14
6400	37.98	0.13
6600	36.50	0.39
6800	35.06	0.49
7000	33.88	0.49
7200	33.00	0.58
7400	33.55	0.59
7600	33.99	0.74
7800	33.97	0.90
8000	33.69	0.92

## Typical Performance Curves

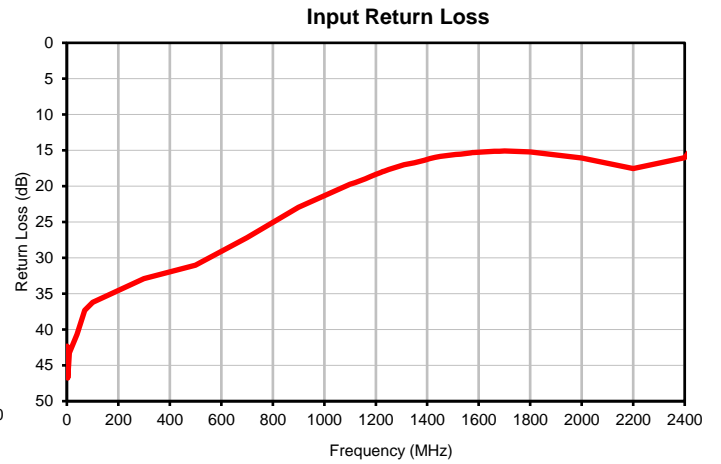
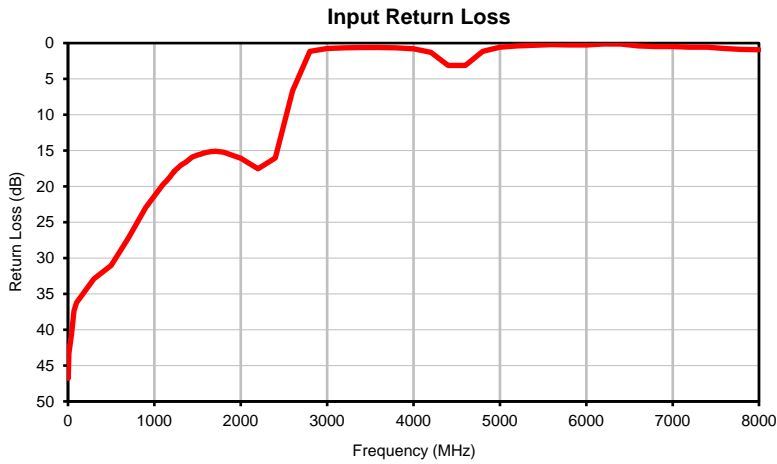
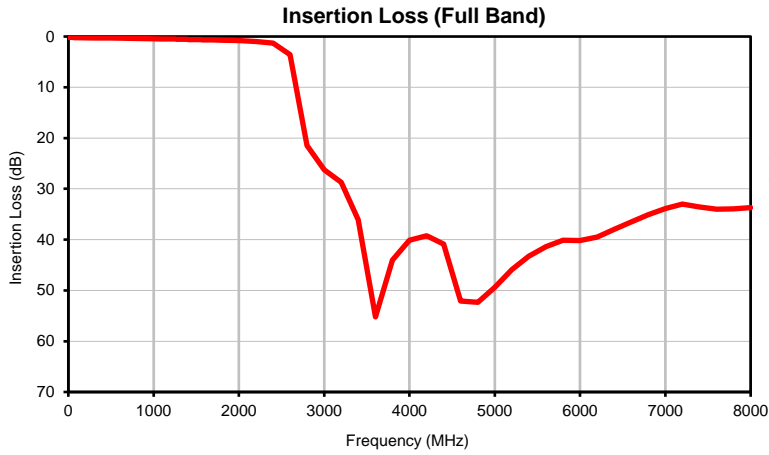

### Outline Dimensions

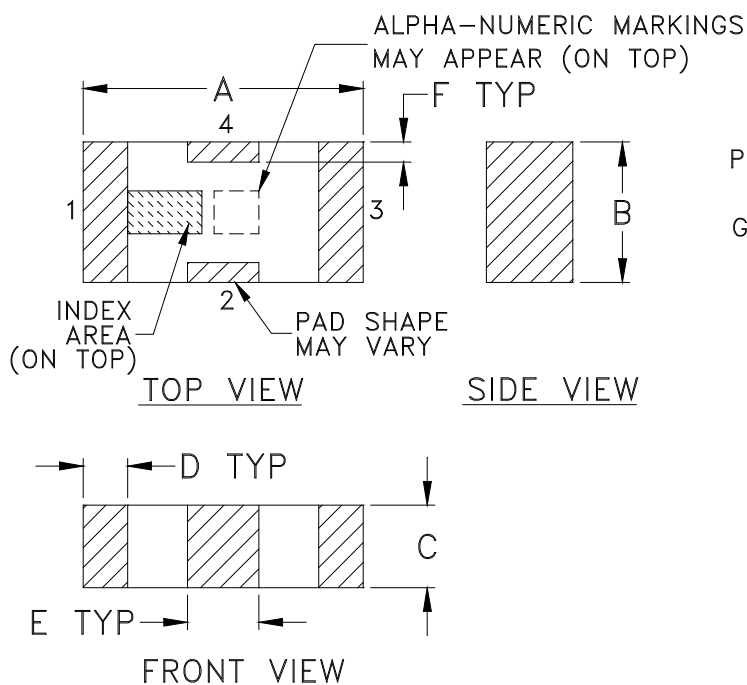

### PCB Land Pattern



Suggested Layout,  
Tolerance to be within  $\pm .002$

CASE #	A	B	C	D	E	F	G	H	J	K	L	M	N	P	WT. GRAM
FV1206	.126 (3.20)	.063 (1.60)	.037 (0.94)	.020 (0.51)	.032 (0.81)	.009 (0.23)	.169 (4.29)	.087 (2.21)	.024 (0.61)	.122 (3.10)	.024 (0.61)	.087 (2.21)	.012 (0.30)	.071 (1.80)	.020

Dimensions are in inches (mm). Tolerances: 2 Pl.  $\pm .01$ ; 3 Pl.  $\pm .005$

#### Notes:

1. Open style, ceramic base.
2. Termination finish: **as shown below or indicated on Data Sheet.**  
For RoHS Case Styles: Tin plate over Nickel plate. All models, (+) suffix.  
For RoHS-5 Case Styles: Tin-Lead plate. All models, no (+) suffix.



P.O. Box 350166, Brooklyn, New York 11235-0003 (718) 934-4500 Fax (718) 332-4661 For detailed performance specs & shopping online see Mini-Circuits web site



The Design Engineers Search Engine Provides ACTUAL Data Instantly From MINI-CIRCUITS At: [www.minicircuits.com](http://www.minicircuits.com)

RF/IF MICROWAVE COMPONENTS

# Tape & Reel Packaging TR-F71



ILLUSTRATION 1

Tape Width, mm	Device Cavity Pitch, mm	Reel Size, inches	Devices per Reel	
8	4	7	Small quantity standards (see note)	20
				50
				100
				200
				500
				1000
			Standard	3000

Note: Please Consult individual model data sheet to determine device per reel availability.

Mini-Circuits carrier tape materials provide protection from ESD (Electro-Static Discharge) during handling and transportation. Tapes are static dissipative and comply with industry standards EIA-481/EIA-541.

Go to: [www.minicircuits.com/pages/pdfs/tape.pdf](http://www.minicircuits.com/pages/pdfs/tape.pdf)



P.O. Box 350166, Brooklyn, New York 11235-0003 (718) 934-4500 Fax (718) 332-4661 For detailed performance specs & shopping online see Mini-Circuits web site



The Design Engineers Search Engine Provides ACTUAL Data Instantly From MINI-CIRCUITS At: [www.minicircuits.com](http://www.minicircuits.com)

RF/IF MICROWAVE COMPONENTS

THIRD ANGLE PROJECTION



REVISIONS

REV	ECN No.	DESCRIPTION	DATE	DR	AUTH
OR	M88634	NEW RELEASE	08/28/03	GF	ABD
A	M102713	ADDED "...WITH SMOBC"	01/17/06	MMG	IL

SUGGESTED MOUNTING CONFIGURATION  
FOR FV1206 CASE STYLE, "nx" PIN CONNECTION



- NOTES:**
1. COPLANAR WAVEGUIDE PARAMETERS ARE SHOWN FOR ROGERS R04350B WITH THICKNESS .020" ± .0015".  
 COPPER: 1/2 OZ. EACH SIDE.  
 FOR OTHER MATERIALS TRACE WIDTH & GAP MAY NEED TO BE MODIFIED.

2. BOTTOM SIDE OF THE PCB IS CONTINUOUS GROUND PLANE.



DENOTES PCB COPPER LAYOUT WITH SMOBC  
 (SOLDER MASK OVER BARE COPPER)



DENOTES COPPER LAND PATTERN FREE OF SOLDER MASK

UNLESS OTHERWISE SPECIFIED

INITIALS

DATE

DIMENSIONS ARE IN INCHES

DRAWN

GF

08/27/03

TOLERANCES ON:

CHECKED

AV

08/28/03

2 PL DECIMALS ±

APPROVED

ABD

08/28/03

3 PL DECIMALS ± .005

ANGLES ±

FRACTIONS ±



THIS DOCUMENT AND ITS CONTENTS ARE THE PROPERTY OF MINI-CIRCUITS. EXCEPT FOR USE EXPRESSLY GRANTED, IN WRITING, TO ITS VENDORS, VENDEE AND THE UNITED STATES GOVERNMENT, MINI-CIRCUITS RESERVES ALL PROPRIETARY DESIGN, USE, MANUFACTURING AND REPRODUCTION RIGHTS THERETO. THESE CONTENTS SHALL NOT BE USED, DUPLICATED OR DISCLOSED TO ANY OUTSIDE PARTY, IN WHOLE OR IN PART, WITHOUT WRITTEN PERMISSION OF MINI-CIRCUITS.

ASHEETA1.DWG REV:A DATE:01/12/95



**Mini-Circuits®**

13 Neptune Avenue  
 Brooklyn NY 11235

PL, nx, FV1206, LFCN/HFCN, TB-270

SIZE  
 A

CODE IDENT  
 15542

DRAWING NO:  
 98-PL-137

REV:  
 A

FILE: 98PL137

SCALE: 10:1

SHEET: 1 OF 1



All Mini-Circuits products are manufactured under exacting quality assurance and control standards, and are capable of meeting published specifications after being subjected to any or all of the following physical and environmental test.

Specification	Test/Inspection Condition	Reference/Spec
Operating Temperature	-55° to 100°C Ambient Environment	Individual Model Data Sheet
Storage Temperature	-55° to 100° C Ambient Environment	Individual Model Data Sheet
Humidity	90 to 95% RH, 240 hours, 50°C	MIL-STD-202, Method 103, Condition A, Except 50°C and end-point electrical test done within 12 hours
Solder Reflow Heat	Sn-Pb Eutetic Process: 225°C peak Pb-Free Process 245° - 250°C peak	J-STD-020, Table 4-1, 4-2 and 5-2, Figure 5-1
Solderability	10X Magnification	J-STD-002, Para 4.2.5, Test S, 95% Coverage
Vibration (High Frequency)	20g peak, 10-2000 Hz, 12 times in each of three perpendicular directions (total 36)	MIL-STD-202, Method 204, Condition D
Mechanical Shock	50g, 11 ms, 1/2-sine, 18 shocks: 3 each direction, each of 3 axes	MIL-STD-202, Method 213, Condition A