

Ceramic Low Pass Filter

LFCV-1452+

50Ω DC to 14500 MHz

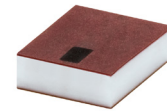

Generic photo used for illustration purposes only
CASE STYLE: JV1210C-7

The Big Deal

- Good rejection, 40 dB typical
- Rugged, ceramic construction
- Small size, 0.126" x 0.098" x 0.039" (1210)
- Good power handling, 3.2W

Product Overview

Mini-Circuits' LFCV-1452+ is an LTCC low pass filter with a passband from DC to 14500 MHz, supporting a variety of applications. This model provides 1.4 dB typical passband insertion loss and provides a very good stopband rejection due to strategically constructed layout with minimal interaction between components. It handles up to 3.2W RF input power and provides a wide operating temperature range from -55 to +125°C. Housed in a small 1210 ceramic form factor, the filter is ideal for dense PCB layouts and with minimal performance variation due to parasitics.

Key Features

Feature	Advantages
Ultra-wide stopband	The LTCC lowpass filter provides a very good stopband rejection until 40 GHz suitable for high end applications.
LTCC Construction	Provides repeatable performance in a rugged, ceramic package well suited for tough environments such as high humidity and temperature extremes.
Small size (0.126" x 0.098" x 0.039")	Saves space in dense circuit board layouts and minimizes the effects of parasitics.
Good power handling, 3.2W	Supports a wide range of system power requirements.

Notes

- A. Performance and quality attributes and conditions not expressly stated in this specification document are intended to be excluded and do not form a part of this specification document.
B. Electrical specifications and performance data contained in this specification document are based on Mini-Circuit's applicable established test performance criteria and measurement instructions.
C. The parts covered by this specification document are subject to Mini-Circuits standard limited warranty and terms and conditions (collectively, "Standard Terms"); Purchasers of this part are entitled to the rights and benefits contained therein. For a full statement of the Standard Terms and the exclusive rights and remedies thereunder, please visit Mini-Circuits' website at www.minicircuits.com/MCLStore/terms.jsp



Low Pass Filter

LFCV-1452+

50Ω DC to 14500 MHz

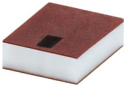

Generic photo used for illustration purposes only
CASE STYLE: JV1210C-7

+RoHS Compliant
The +Suffix identifies RoHS Compliance. See our web site for RoHS Compliance methodologies and qualifications

Features

- Low loss, 1.4 dB typical
- Good rejection 40 dB typical
- Good power handling, 3.2W
- Small size 1210 (0.126" x 0.098" x 0.039")
- Temperature stable
- LTCC construction

Applications

- Military radar applications
- Test and measurement
- Telecommunications & broadband wireless applications

Functional Schematic

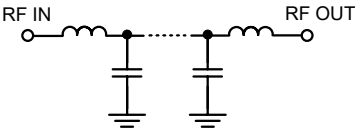

Electrical Specifications^{1,2} at 25°C

Parameter		F#	Frequency (MHz)	Min.	Typ.	Max.	Unit
Pass Band	Insertion Loss	DC-F1	DC - 14500	—	1.4	1.9	dB
	Frequency Cut-off	F2*	15800	—	3	—	dB
	Return Loss	DC-F1	DC - 14500	—	12	—	dB
Stop Band	Rejection Loss	F3-F4	20000 - 23000	20	40	—	dB
		F4-F5	23000 - 26500	30	40	—	dB
		F5-F6	26500 - 32000	—	38	—	dB
		F6-F7	32000 - 40000	—	20	—	dB

1 DC de-coupling capacitors are required in Applications where DC voltage and/or current is present at either input or output ports. Please contact Mini-Circuits for alternatives if DC pass from IN-OUT is required.

2 Measured on Mini-Circuits Characterization Test Board TB-LFCV-1452+

* Typically, a ±5% frequency deviation from the stated value may occur on a unit-to-unit basis.

Maximum Ratings

Operating Temperature	-55°C to 125°C
Storage Temperature	-55°C to 125°C
RF Power Input*	3.2W max. @25°C

*Passband rating, derate linearly to 1.6W at 125°C ambient
Permanent damage may occur if any of these limits are exceeded.

Typical Performance Data at 25°C

Frequency (MHz)	Insertion Loss (dB)	Return Loss (dB)
10	0.07	51.74
100	0.08	45.70
300	0.12	37.25
400	0.13	34.75
500	0.14	32.81
1000	0.18	26.68
5000	0.42	17.87
10000	0.49	26.46
14500	1.06	14.61
15800	2.31	7.88
16200	3.32	5.56
17000	7.43	2.15
19000	22.80	0.96
20000	32.99	1.05
23000	39.31	1.35
25000	46.27	2.02
26500	41.44	2.47
30000	46.37	0.55
32000	45.90	1.00
40000	39.12	1.60

Typical Frequency Response

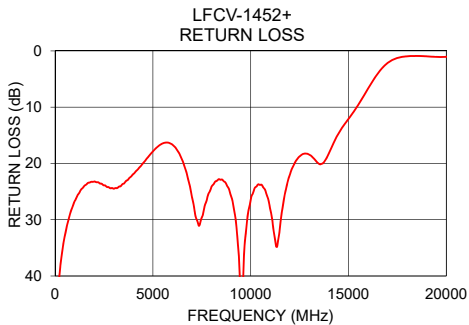
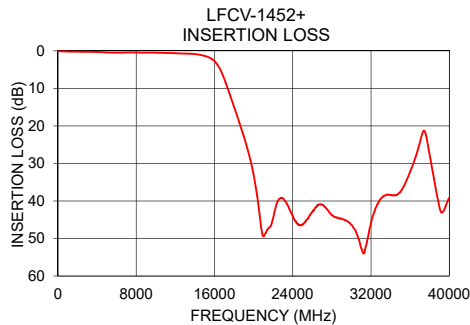
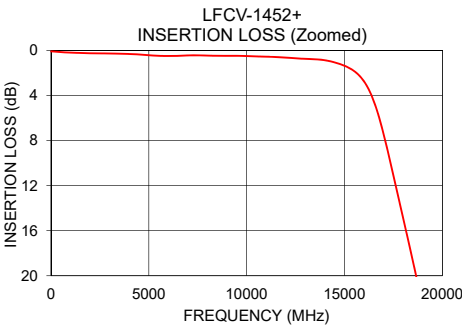
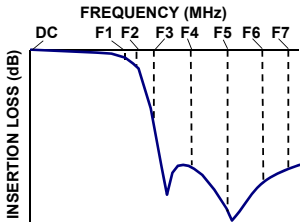

Notes

- A. Performance and quality attributes and conditions not expressly stated in this specification document are intended to be excluded and do not form a part of this specification document.
- B. Electrical specifications and performance data contained in this specification document are based on Mini-Circuit's applicable established test performance criteria and measurement instructions.
- C. The parts covered by this specification document are subject to Mini-Circuits standard limited warranty and terms and conditions (collectively, "Standard Terms"); Purchasers of this part are entitled to the rights and benefits contained therein. For a full statement of the Standard Terms and the exclusive rights and remedies thereunder, please visit Mini-Circuits' website at www.minicircuits.com/MCLStore/terms.jsp



Pad Connections

INPUT	1
OUTPUT	2
GROUND	3

Product Marking: MH

Demo Board MCL P/N: TB-LFCV-1452+
Suggested PCB Layout (PL-679)

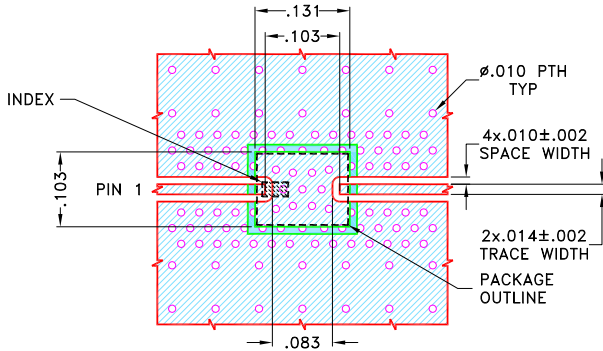

NOTES:

1. COPLANAR WAVEGUIDE PARAMETERS ARE SHOWN FOR ROGERS (R04835 Lo Pro) WITH DIELECTRIC THICKNESS .0073±.0007, COPPER: 1/2 Oz. EACH SIDE. FOR OTHER MATERIALS TRACE WIDTH AND GAP MAY NEED TO BE MODIFIED.
 2. BOTTOM SIDE OF THE PCB IS CONTINUOUS GROUND PLANE.
- DENOTES PCB COPPER PATTERN WITH SMOBC (SOLDER MASK OVER BARE COPPER)
■ DENOTES PCB COPPER PATTERN FREE OF SOLDERMASK

Outline Drawing

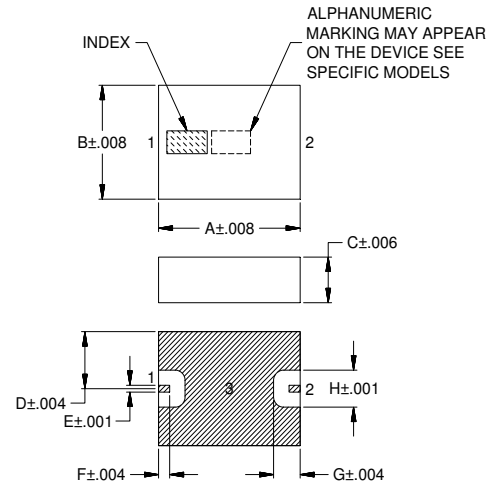

Outline Dimensions (inch mm)

A	B	C	D	E
.126	.098	.037	.049	.006
3.20	2.50	0.95	1.25	0.15

F	G	H	Wt.
.010	.024	.032	grams
0.25	0.60	0.81	0.03

Note: Please refer to case style drawing for details

Notes

- Performance and quality attributes and conditions not expressly stated in this specification document are intended to be excluded and do not form a part of this specification document.
- Electrical specifications and performance data contained in this specification document are based on Mini-Circuit's applicable established test performance criteria and measurement instructions.
- The parts covered by this specification document are subject to Mini-Circuits standard limited warranty and terms and conditions (collectively, "Standard Terms"); Purchasers of this part are entitled to the rights and benefits contained therein. For a full statement of the Standard Terms and the exclusive rights and remedies thereunder, please visit Mini-Circuits' website at www.minicircuits.com/MCLStore/terms.jsp

Typical Performance Data

FREQ.	Insertion Loss	Input Return Loss	Output Return Loss
(MHz)	(dB)	(dB)	(dB)
10	0.07	51.74	48.03
50	0.08	48.52	47.95
100	0.08	45.70	44.91
500	0.14	32.81	32.23
1000	0.18	26.68	26.29
2000	0.24	23.22	23.29
2500	0.25	23.90	23.72
3000	0.26	24.49	24.07
4000	0.31	21.89	22.07
5000	0.42	17.87	17.51
6000	0.48	16.67	17.13
6500	0.47	19.39	19.11
7000	0.43	26.02	25.53
7500	0.43	29.60	33.19
8000	0.45	24.12	25.03
9000	0.47	25.86	26.71
10000	0.49	26.46	25.70
10500	0.52	23.81	22.84
11000	0.55	28.15	24.12
11500	0.58	31.30	25.68
11700	0.59	26.33	24.73
12000	0.63	22.04	22.42
12400	0.67	19.13	20.19
12500	0.69	18.76	19.85
13000	0.74	18.46	20.73
13600	0.78	20.11	26.44
14000	0.86	18.19	22.10
14500	1.06	14.61	16.14
15000	1.35	12.09	12.82
15800	2.31	7.88	8.09
16200	3.32	5.56	5.55
18000	14.92	0.96	1.07
19000	22.80	0.96	1.02
20000	32.99	1.05	0.89
20600	43.36	0.91	0.90
21000	49.43	0.82	1.09
21500	47.36	0.71	1.47
22000	44.52	0.71	2.24
22500	39.94	0.91	3.18
23000	39.31	1.35	2.99
23500	41.22	2.16	1.94
24000	43.96	2.93	1.38
24500	46.14	2.72	1.29
25000	46.27	2.02	1.38
25500	44.86	1.65	1.47
26000	42.89	1.88	1.32
26500	41.44	2.47	0.86
27000	40.99	2.18	0.60
27500	42.16	1.81	0.39
28000	43.79	1.25	0.27
28500	44.48	0.82	0.24
30000	46.37	0.55	0.82
31000	52.62	0.84	1.08
32000	45.90	1.00	0.90
33000	39.35	0.88	0.80
34000	38.38	0.73	1.05
35000	37.65	0.87	1.53
37000	24.35	1.62	1.37
39000	41.76	0.89	1.90
40000	39.12	1.60	1.07

FREQ.	Group Delay
(MHz)	(ns)
10	0.21
50	0.08
100	0.07
300	0.07
500	0.06
600	0.06
800	0.06
1000	0.06
1200	0.06
1400	0.06
1600	0.06
1800	0.06
2000	0.06
2200	0.06
2400	0.06
2600	0.06
2800	0.06
3000	0.06
3200	0.06
3400	0.06
3600	0.06
3800	0.06
4000	0.06
4200	0.06
4400	0.06
4600	0.06
4800	0.06
5000	0.06
5200	0.06
5400	0.06
5600	0.06
5800	0.06
6000	0.06
6200	0.06
6400	0.06
6600	0.06
6800	0.07
7000	0.07
7200	0.07
7400	0.07
7600	0.07
7800	0.07
8000	0.07
8200	0.07
8400	0.07
8600	0.07
8800	0.07
9000	0.07
9200	0.07
9400	0.07
9600	0.07
9800	0.07
10000	0.07
10200	0.07
11000	0.08
11500	0.08
12000	0.08
13000	0.09
13500	0.10
14500	0.11



Typical Performance Curves

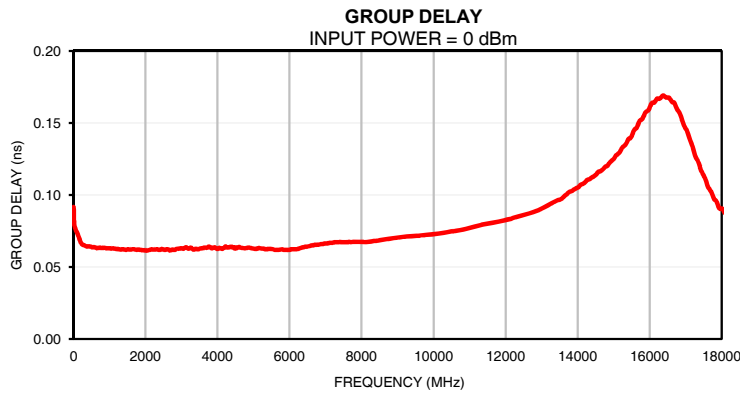
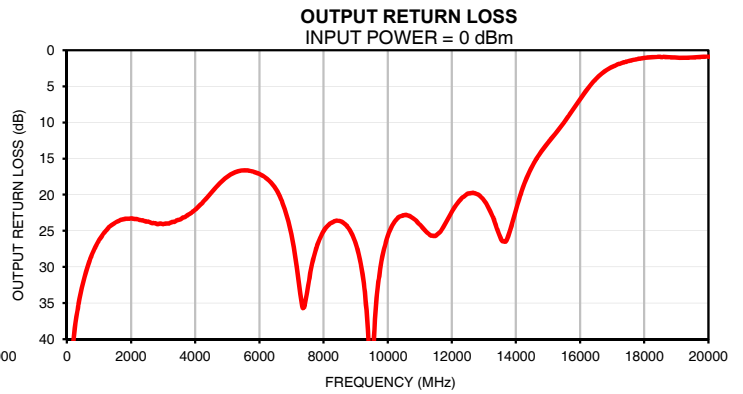
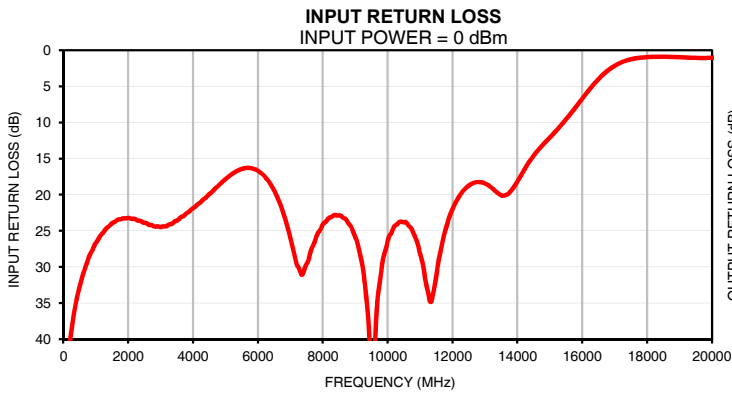
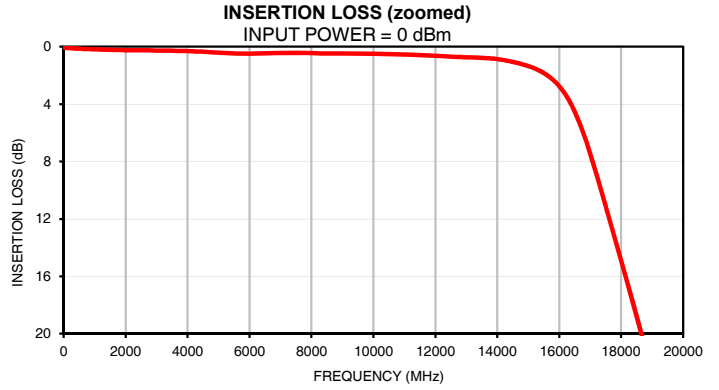
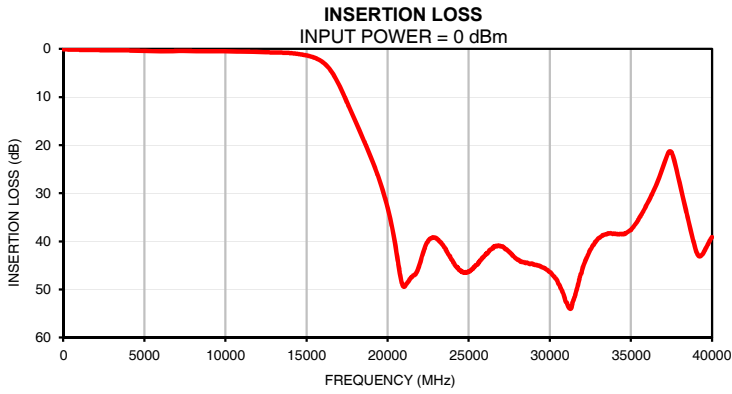

Case Style

JV

Outline Dimensions

JV1210C-7

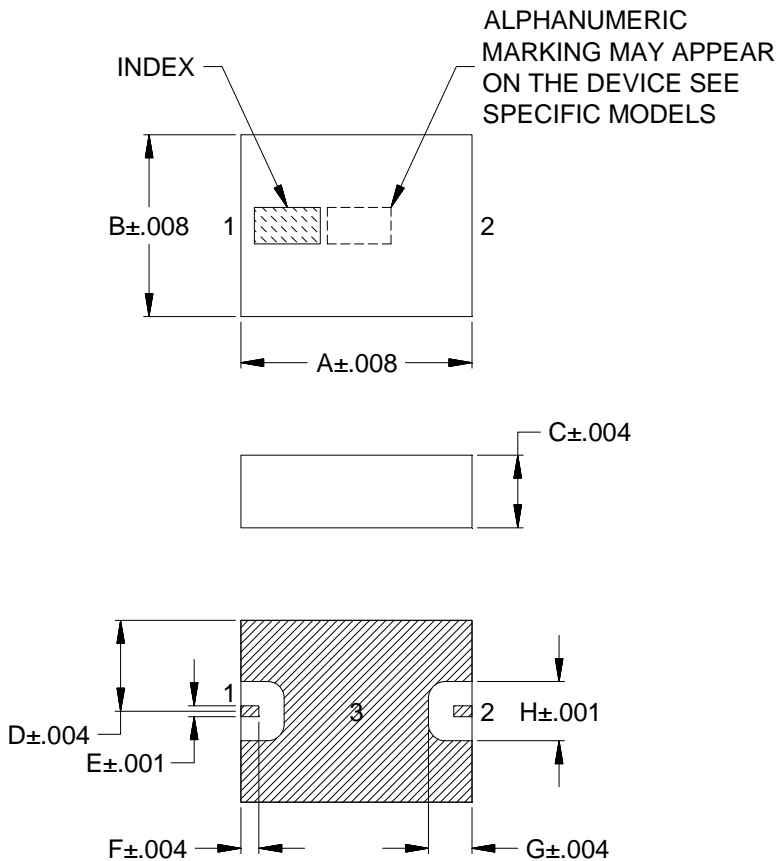

PCB LAND PATTERN

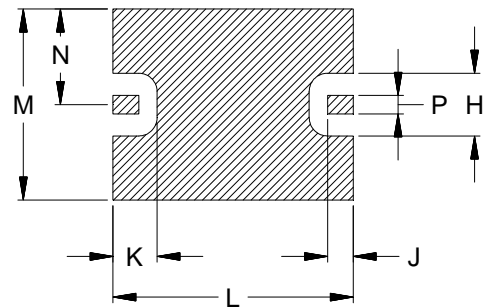

SUGGESTED LAYOUT
TOLERANCE TO BE WITHIN $\pm .002$

 METALLIZATION

CASE#	A	B	C	D	E	F	G	H	J	K	L	M	N	P	WT.GRAM
JV1210C-7	.126 (3.20)	.098 (2.50)	.039 (1.00)	.049 (1.25)	.006 (0.15)	.010 (0.25)	.024 (0.60)	.032 (0.81)	.014 (0.36)	.024 (0.61)	.131 (3.33)	.103 (2.63)	.052 (1.31)	.010 (0.25)	0.03

Dimensions are in inches (mm). Tolerances: 2Pl. $\pm .01$; 3Pl. $\pm .005$

Notes:

1. Open style, Ceramic base.
2. Termination finish: **as shown below or indicated on Data Sheet.**
For RoHS Case Styles: Gold plate over Nickel plate. All models, (+) suffix.
3. Pad tolerance is non-cumulative. Minimum spacing between each pad is .004.

 **Mini-Circuits**[®]
ISO 9001 ISO 14001 CERTIFIED

ALL NEW

P.O. Box 350166, Brooklyn, New York 11235-0003 (718) 934-4500 Fax (718) 332-4661 For detailed performance specs & shopping online see Mini-Circuits web site



The Design Engineers Search Engine Provides ACTUAL Data Instantly From MINI-CIRCUITS At: www.minicircuits.com

RF/IF MICROWAVE COMPONENTS

Tape & Reel Packaging TR-F74

DEVICE ORIENTATION IN T&R



ILLUSTRATION 1

Applicable Case Styles

GE0805C-1
GE0805C-1AP
JV1210C-1
GU2939



ILLUSTRATION 2

Applicable Case Styles

JV1210C
JV1210C-2
JV1210C-3
JV1210C-4
JV1210C-5
JV1210C-6
JV1210C-11

ILLUSTRATION 3

Applicable Case Styles

JC0603C-8
JC0603C-9
JV1210C-7
JV1210C-8
JV1210C-9
JV1210C-10
JV1210C-13
GE0805C-13
GE0805C-19
GE0805C-20

Tape Width, mm	Device Cavity Pitch, mm	Real Size, inches	Devices per Reel	
8	4	7	Small quantity standards (see note)	20
				50
				100
				200
				500
				1000
			Standard	2000
				4000

Note: Small reel availability varies by model. Refer to pricing and availability on individual model dashboard.

Mini-Circuits carrier tape materials provide protection from ESD (Electro-Static Discharge) during handling and transportation. Tapes are static dissipative and comply with industry standards EIA-481/EIA-541.

Go to: www.minicircuits.com/pages/pdfs/tape.pdf



Distribution Centers NORTH AMERICA 800-654-7949 • 417-335-5935 • Fax 417-335-5945 • EUROPE 44-1252-832600 • Fax 44-1252-837010

Mini-Circuits ISO 9001 & ISO 14001 Certified

INTERNET <http://www.minicircuits.com>

P.O. Box 350166, Brooklyn, New York 11235-0003 (718) 934-4500 Fax (718) 332-4661

THIRD ANGLE PROJECTION

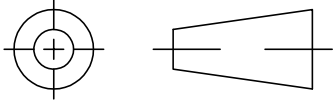

REVISIONS

REV	ECN No.	DESCRIPTION	DATE	DR	AUTH
OR	ECO-003129	NEW RELEASE	JUL 20	DDR	VC
OR1	ECO-019409	JV1210C-13 ADDED	OCT 23	AGS	VC

SUGGESTED MOUNTING CONFIGURATION FOR JV1210C-7, JV1210C-13 CASE STYLE

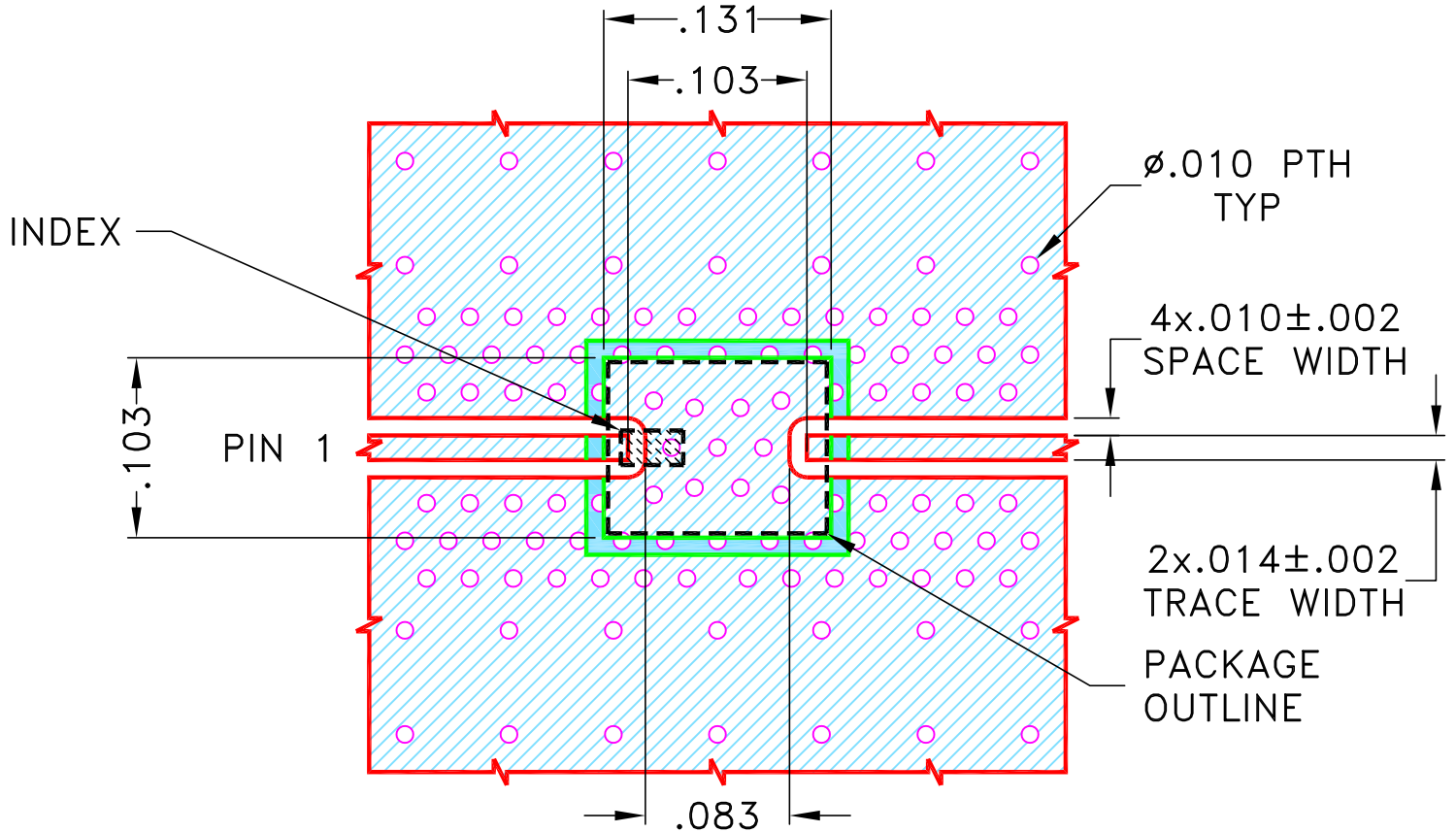

NOTES:

- COPLANAR WAVEGUIDE PARAMETERS ARE SHOWN FOR ROGERS (R04835 Lo Pro) WITH DIELECTRIC THICKNESS $.0073 \pm .0007$. COPPER: 1/2 Oz. EACH SIDE. FOR OTHER MATERIALS TRACE WIDTH AND GAP MAY NEED TO BE MODIFIED.
- BOTTOM SIDE OF THE PCB IS CONTINUOUS GROUND PLANE.

- DENOTES PCB COPPER PATTERN WITH SMOBC (SOLDER MASK OVER BARE COPPER)
- DENOTES PCB COPPER PATTERN FREE OF SOLDERMASK

UNLESS OTHERWISE SPECIFIED	INITIALS	DATE
DIMENSIONS ARE IN INCHES	DRAWN	DDR 02 JUL 20
TOLERANCES ON:	CHECKED	RV 02 JUL 20
2 PL DECIMALS ±	APPROVED	RKS 02 JUL 20
3 PL DECIMALS ± .005"		
ANGLES ±		
FRACTIONS ±		

Mini-Circuits® 13 Neptune Avenue
Brooklyn NY 11235

PL, JV1210C-7, JV1210C-13, TB-LFCV-X+

Mini-Circuits®
THIS DOCUMENT AND ITS CONTENTS ARE THE PROPERTY OF MINI-CIRCUITS. EXCEPT FOR USE EXPRESSLY GRANTED, IN WRITING, TO ITS VENDORS, VENDEE AND THE UNITED STATES GOVERNMENT, MINI-CIRCUITS RESERVES ALL PROPRIETARY DESIGN, USE, MANUFACTURING AND REPRODUCTION RIGHTS THERETO. THESE CONTENTS SHALL NOT BE USED, DUPLICATED OR DISCLOSED TO ANY OUTSIDE PARTY, IN WHOLE OR IN PART, WITHOUT WRITTEN PERMISSION OF MINI-CIRCUITS.

SIZE	CODE IDENT	DRAWING NO:	REV:
A	15542	98-PL-679	OR1
FILE:	98PL679	SCALE:	9:1
		SHEET:	1 OF 1

CONNECTOR ASSEMBLY

TOP VIEW

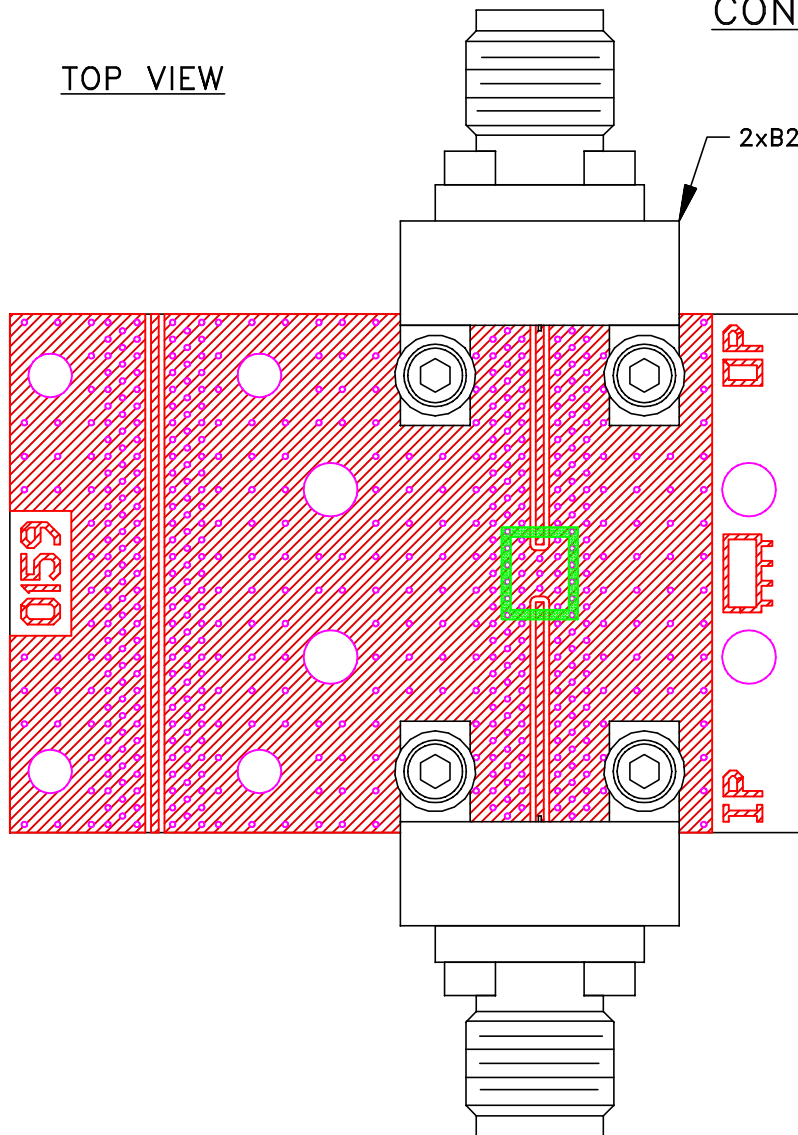

BOTTOM VIEW

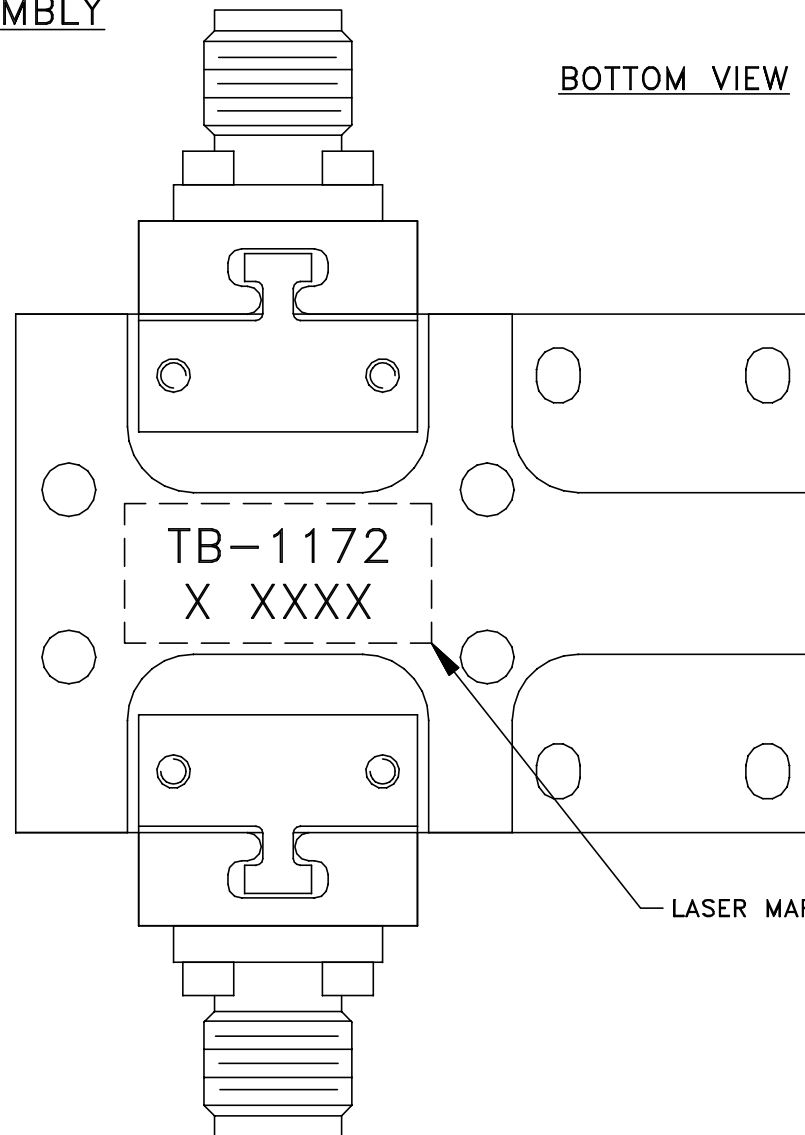

Mini-Circuits® <small>THIS DOCUMENT AND ITS CONTENTS ARE THE PROPERTY OF MINI-CIRCUITS. EXCEPT FOR USE EXPRESSLY GRANTED, IN WRITING, TO ITS VENDORS, VENDEE AND THE UNITED STATES GOVERNMENT, MINI-CIRCUITS RESERVES ALL PROPRIETARY DESIGN, USE, MANUFACTURING AND REPRODUCTION RIGHTS THEREON. THESE CONTENTS SHALL NOT BE USED, DUPLICATED OR DISCLOSED TO ANY OUTSIDE PARTY, IN WHOLE OR IN PART, WITHOUT WRITTEN PERMISSION OF MINI-CIRCUITS.</small>		<small>ALL DIMENSIONS ARE IN INCHES EXCEPT OTHERWISE SPECIFIED</small>		
<small>SIZE</small> B	<small>CODE IDENT</small> 15542	<small>DRAWING NO:</small> TB-1172-20	<small>REV:</small> OR	
<small>FILE:</small>	WTB-1172	<small>SCALE:</small>	4:1	<small>SHEET:</small>
		2 OF 2		

All Mini-Circuits products are manufactured under exacting quality assurance and control standards, and are capable of meeting published specifications after being subjected to any or all of the following physical and environmental test.

Specification	Test/Inspection Condition	Reference/Spec
Operating Temperature	-55° to 125° C Ambient Environment	Individual Model Data Sheet
Storage Temperature	-55° to 125° C Ambient Environment	Individual Model Data Sheet
Humidity	90 to 95% RH, 240 hours, 50°C	MIL-STD-202, Method 103, Condition A, Except 50°C and end-point electrical test done within 12 hours
Solder Reflow Heat	Sn-Pb Eutectic Process 225°C peak Pb-Free Process 245° - 250°C peak	J-STD-020C, Table 4-1, 4-2 and 5-2, Figure 5-1
Solderability	10X Magnification	J-STD-002, Para 4.2.5, Test S, 95% Coverage
Vibration (High Frequency)	20g peak, 10-2000 Hz, 12 times in each of three perpendicular directions (total 36)	MIL-STD-202, Method 204, Condition D
Mechanical Shock	50g, 11 ms, 1/2-sine, 18 shocks: 3 each direction, each of 3 axes	MIL-STD-202, Method 213, Condition A