

# Ceramic Low Pass Filter

## LFCW-133+

50Ω DC to 13.25 GHz

### The Big Deal

- Small size 0603 (1.6 x 0.8 mm)
- Low insertion Loss, 2.2 dB typical
- Rejection 20 dB typical from 14.76 to 17 GHz
- Good power handling, 12.6W



CASE STYLE: JC0603C-1

### Product Overview

Mini-Circuits' LFCW-133+ is a Low Temperature Co-fired Ceramic (LTCC) low pass filter, designed in a very small, 0603 package. The multilayer construction provides high repeatability of performance. Small, wrap-around terminations minimize variations in performance due to parasitics. Covering DC – 13.25 GHz, these units offer low insertion loss, good rejection, and excellent power handling capability.

### Key Features

Feature	Advantages
Small size 0603 (1.6 x 0.8 mm)	Allows for high layout density of circuit boards while minimizing the effects of parasitics.
Stop band rejection 20dB typical over 14.76 - 17 GHz	Provides good rejection in a tiny package, saving PCB space for customers.
Wrap-around terminations	Provides excellent solderability and easy visual inspection.
LTCC construction	Rugged package, well-suited for tough environments including high humidity and high temperature extremes.

#### Notes

- A. Performance and quality attributes and conditions not expressly stated in this specification document are intended to be excluded and do not form a part of this specification document.  
B. Electrical specifications and performance data contained in this specification document are based on Mini-Circuit's applicable established test performance criteria and measurement instructions.  
C. The parts covered by this specification document are subject to Mini-Circuits standard limited warranty and terms and conditions (collectively, "Standard Terms"); Purchasers of this part are entitled to the rights and benefits contained therein. For a full statement of the Standard Terms and the exclusive rights and remedies thereunder, please visit Mini-Circuits' website at [www.minicircuits.com/MCLStore/terms.jsp](http://www.minicircuits.com/MCLStore/terms.jsp)



# Ceramic Low Pass Filter

50Ω DC<sup>1</sup> to 13.25 GHz

## LFCW-133+



Generic photo used for illustration purposes only

CASE STYLE: JC0603C-1

**+RoHS Compliant**

The +Suffix identifies RoHS Compliance. See our web site for RoHS Compliance methodologies and qualifications

### Features

- Good power handling, 12.6W
- Small size 0603 (1.6 x 0.8 mm)
- 7 sections
- Temperature stable
- LTCC construction

### Applications

- Harmonic Rejection
- VHF/UHF transmitters / receivers
- lab use

### Electrical Specifications<sup>1,2</sup> at 25°C

Parameter	F#	Frequency (GHz)	Min.	Typ.	Max.	Unit
<b>Pass Band</b>	Insertion Loss	DC - F1	DC - 13.25	—	2.5	dB
	Freq. Cut-Off	F2	13.65	—	3.0	dB
	VSWR	DC - F1	DC - 13.25	—	2.7	:1
<b>Stop Band</b>	Rejection Loss	F3	14.76	—	20	dB
		F4 - F5	14.91 - 15.41	19	24	:1
		F6	17	—	20	dB

1. In Application where DC voltage is present at either input or output port, coupling capacitors are required.
2. Measured on Mini-Circuits Characterization Test Board TB-720+

### Functional Schematic

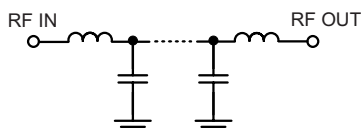

### Maximum Ratings

Operating Temperature	-55°C to 100°C
Storage Temperature	-55°C to 100°C
RF Power Input <sup>3</sup>	12.6W at 25°C

3. Passband rating, derate linearly to 6.3W at 100°C ambient ([Reference AN-75-005](#))  
Permanent damage may occur if any of these limits are exceeded.

### Typical Frequency Response

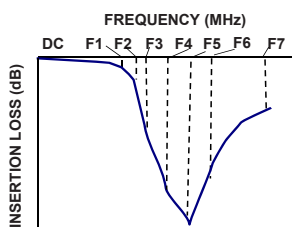

### Typical Performance Data<sup>4</sup> at 25°C

Frequency (GHz)	Insertion Loss (dB)	VSWR (:1)
0.01	0.08	1.07
0.50	0.12	1.08
1.00	0.17	1.18
3.00	0.57	1.72
5.00	0.66	1.74
7.00	0.50	1.37
10.00	0.78	1.50
12.82	1.20	1.30
13.25	1.57	1.46
13.65	2.29	1.40
14.91	26.98	20.50
15.41	48.34	26.13
16.00	33.38	26.98
16.50	25.56	23.93
17.00	20.65	21.16
18.50	14.50	17.10
20.00	13.20	16.80

4. Measured with Agilent E5071B network analyzer using port extension.

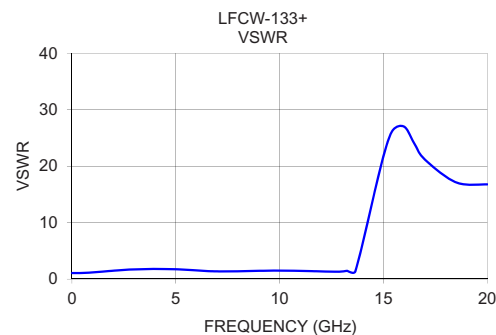
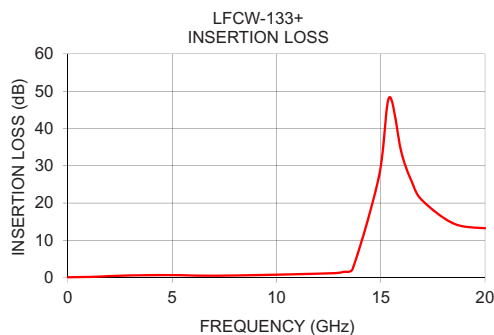

### Notes

- Performance and quality attributes and conditions not expressly stated in this specification document are intended to be excluded and do not form a part of this specification document.
- Electrical specifications and performance data contained in this specification document are based on Mini-Circuits' applicable established test performance criteria and measurement instructions.
- The parts covered by this specification document are subject to Mini-Circuits standard limited warranty and terms and conditions (collectively, "Standard Terms"); Purchasers of this part are entitled to the rights and benefits contained therein. For a full statement of the Standard Terms and the exclusive rights and remedies thereunder, please visit Mini-Circuits' website at [www.minicircuits.com/MCLStore/terms.jsp](http://www.minicircuits.com/MCLStore/terms.jsp)



[www.minicircuits.com](http://www.minicircuits.com) P.O. Box 350166, Brooklyn, NY 11235-0003 (718) 934-4500 sales@minicircuits.com

REV. B  
M151107  
ED-15030/1  
LFCW-133+  
MY/CP/AM  
20513

## Pad Connections

INPUT	1
OUTPUT	3
GROUND	2,4

## Product Marking: N/A

### Evaluation Board MCL P/N: TB-720+ Suggested PCB Layout (PL-412)

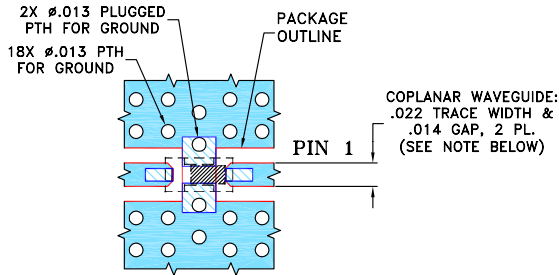

#### NOTES:

- TRACE WIDTH IS SHOWN FOR ROGERS R04350B WITH DIELECTRIC THICKNESS .010" ± .001". COPPER: 1/2 OZ. EACH SIDE. FOR OTHER MATERIALS TRACE WIDTH AND GAP MAY NEED TO BE MODIFIED.
- BOTTOM SIDE OF THE PCB IS CONTINUOUS GROUND PLANE.

 DENOTES PCB COPPER LAYOUT WITH SMOBC (SOLDER MASK OVER BARE COPPER).

 DENOTES COPPER LAND PATTERN FREE OF SOLDER MASK.

## Outline Drawing

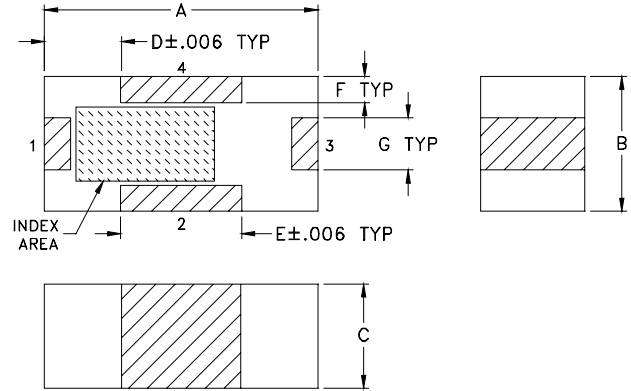

### Outline Dimensions (inch/mm)

A	B	C	D	E	F	G	wt
.063	.031	.024	.018	.028	.006	.012	grams
1.60	0.79	0.61	0.46	0.71	0.15	0.30	0.005

#### Notes

- Performance and quality attributes and conditions not expressly stated in this specification document are intended to be excluded and do not form a part of this specification document.
- Electrical specifications and performance data contained in this specification document are based on Mini-Circuit's applicable established test performance criteria and measurement instructions.
- The parts covered by this specification document are subject to Mini-Circuits standard limited warranty and terms and conditions (collectively, "Standard Terms"); Purchasers of this part are entitled to the rights and benefits contained therein. For a full statement of the Standard Terms and the exclusive rights and remedies thereunder, please visit Mini-Circuits' website at [www.minicircuits.com/MCLStore/terms.jsp](http://www.minicircuits.com/MCLStore/terms.jsp)

Typical Performance Data

FREQ. (MHz)	INSERTION LOSS (dB)			INPUT RETURN LOSS (dB)			OUTPUT RETURN LOSS (dB)		
	@-55°C	@+25°C	@+100°C	@-55°C	@+25°C	@+100°C	@-55°C	@+25°C	@+100°C
	10.0	0.05	0.06	0.07	29.09	28.84	28.59	28.38	28.10
20.0	0.04	0.05	0.07	36.13	34.84	34.17	35.56	34.36	33.80
30.0	0.05	0.06	0.07	41.38	38.43	37.10	41.28	38.66	37.18
40.0	0.05	0.06	0.07	47.45	41.84	39.55	47.24	41.73	39.42
50.0	0.05	0.06	0.08	51.65	44.87	41.61	54.88	44.61	41.20
60.0	0.06	0.07	0.08	48.89	47.80	43.69	52.80	47.01	42.57
70.0	0.06	0.07	0.08	47.00	49.27	45.07	49.68	48.34	43.66
80.0	0.06	0.07	0.09	44.98	49.06	46.42	47.28	49.68	44.95
90.0	0.06	0.07	0.09	43.48	48.60	49.00	45.16	48.20	45.52
100.0	0.06	0.07	0.09	42.57	47.08	50.58	43.79	47.02	46.02
100.0	0.06	0.07	0.09	42.57	47.08	50.58	43.79	47.02	46.02
200.0	0.06	0.08	0.11	40.64	36.69	34.67	39.55	36.82	35.04
300.0	0.06	0.09	0.12	34.67	32.85	30.93	34.39	32.89	31.31
400.0	0.07	0.10	0.13	30.35	29.94	29.10	30.74	30.00	29.06
500.0	0.07	0.11	0.15	28.48	27.50	26.66	28.68	27.71	26.73
600.0	0.07	0.12	0.16	26.89	25.79	24.76	27.09	26.02	25.00
700.0	0.08	0.13	0.18	25.33	24.32	23.34	25.51	24.53	23.54
800.0	0.08	0.14	0.19	23.82	22.96	22.06	23.95	23.13	22.20
900.0	0.09	0.16	0.21	22.74	21.91	21.08	22.93	22.07	21.21
1000.0	0.09	0.16	0.22	21.94	21.06	20.25	22.09	21.21	20.36
1100.0	0.10	0.17	0.24	21.07	20.25	19.44	21.23	20.41	19.57
1200.0	0.10	0.19	0.26	20.31	19.45	18.70	20.46	19.60	18.83
1300.0	0.11	0.20	0.27	19.63	18.77	18.06	19.75	18.90	18.16
1400.0	0.12	0.21	0.29	18.99	18.14	17.45	19.11	18.26	17.54
1500.0	0.13	0.23	0.31	18.46	17.66	17.00	18.55	17.73	17.06
1600.0	0.14	0.24	0.33	17.87	17.10	16.51	17.96	17.19	16.56
1700.0	0.15	0.25	0.34	17.40	16.61	16.04	17.49	16.71	16.12
1800.0	0.15	0.27	0.36	16.99	16.19	15.66	17.08	16.28	15.74
1900.0	0.17	0.28	0.38	16.51	15.84	15.37	16.60	15.92	15.44
2000.0	0.18	0.30	0.40	16.10	15.52	15.10	16.18	15.59	15.17
2500.0	0.24	0.37	0.48	14.39	14.09	14.00	14.44	14.15	14.05
3000.0	0.31	0.44	0.54	12.89	13.15	13.43	12.98	13.21	13.48
3500.0	0.37	0.50	0.60	11.86	12.44	13.05	11.98	12.54	13.14
4000.0	0.44	0.56	0.67	10.92	11.72	12.49	11.01	11.77	12.54
4500.0	0.49	0.62	0.74	10.38	11.19	12.00	10.50	11.26	12.05
5000.0	0.51	0.66	0.81	10.19	10.84	11.50	10.26	10.89	11.54
5500.0	0.50	0.69	0.87	10.20	10.72	11.22	10.28	10.75	11.20
6000.0	0.43	0.65	0.87	10.82	11.23	11.58	10.93	11.28	11.61
6500.0	0.37	0.60	0.84	11.60	12.22	12.56	11.66	12.23	12.54
7000.0	0.29	0.52	0.77	13.02	14.13	14.61	13.03	14.02	14.48
7500.0	0.20	0.46	0.72	15.78	17.30	17.80	15.72	17.13	17.67
8000.0	0.14	0.43	0.71	21.38	23.45	24.01	20.34	21.60	22.24
8500.0	0.12	0.45	0.74	34.55	30.88	29.97	26.44	23.46	23.50
9000.0	0.21	0.52	0.84	17.97	19.48	20.48	18.12	18.42	18.84
9500.0	0.35	0.66	0.98	13.52	14.90	15.89	13.61	14.59	15.35
10000.0	0.52	0.82	1.15	11.03	12.32	13.04	11.04	12.11	12.76
10500.0	0.65	0.96	1.29	9.91	11.11	11.83	10.01	11.20	11.88
11000.0	0.67	0.99	1.31	10.22	11.47	12.14	10.23	11.56	12.19
11500.0	0.71	0.98	1.35	10.35	12.68	13.75	10.47	12.63	13.47
12000.0	0.58	0.96	1.37	13.16	15.29	16.34	13.56	15.68	16.65
12500.0	0.62	1.05	1.48	15.14	20.96	21.74	16.50	21.86	23.68
12820.0	0.66	1.14	1.65	17.68	24.66	26.03	21.12	29.15	27.73
13000.0	0.74	1.25	1.77	17.19	23.71	23.34	18.65	30.34	30.79
13250.0	0.91	1.49	2.09	17.95	22.69	21.03	16.89	21.22	22.67
13500.0	1.17	1.96	2.74	26.25	21.36	18.11	16.77	15.71	14.94
13650.0	1.48	2.48	3.44	23.88	15.80	13.71	15.84	12.42	11.27
14000.0	3.28	4.95	6.49	8.75	7.20	6.78	7.50	6.44	6.14
14500.0	13.17	14.69	16.72	1.38	2.03	2.60	1.47	2.20	2.62
14760.0	21.41	23.32	26.99	0.75	1.39	2.05	0.71	1.38	1.91
14910.0	26.17	31.29	38.48	0.75	1.29	1.71	0.81	1.51	1.87
15000.0	29.12	37.21	39.60	0.83	1.24	1.60	0.78	1.37	1.68
15410.0	34.15	34.08	34.49	0.27	0.67	1.02	0.31	0.83	1.13
15500.0	34.52	35.08	35.22	0.15	0.61	1.00	0.31	0.82	1.11
16000.0	43.20	38.66	39.49	0.14	0.53	0.89	0.13	0.57	0.82
16500.0	33.43	33.19	31.83	0.06	0.45	0.79	0.17	0.55	0.79
17000.0	25.55	26.13	26.09	0.01	0.45	0.73	0.06	0.58	0.93
17500.0	21.33	21.77	21.78	0.12	0.52	0.95	0.08	0.53	0.94
18000.0	18.37	18.63	18.63	0.08	0.54	1.09	0.12	0.83	1.42
18500.0	15.94	16.30	16.50	0.06	0.66	1.26	0.01	0.76	1.54
19000.0	14.53	14.17	14.47	0.17	0.83	1.72	0.26	0.95	1.75
19500.0	13.23	12.95	13.09	0.01	0.82	1.82	0.35	1.21	2.21
20000.0	11.69	12.12	12.72	0.22	0.97	1.84	0.42	0.95	1.74



## Typical Performance Data

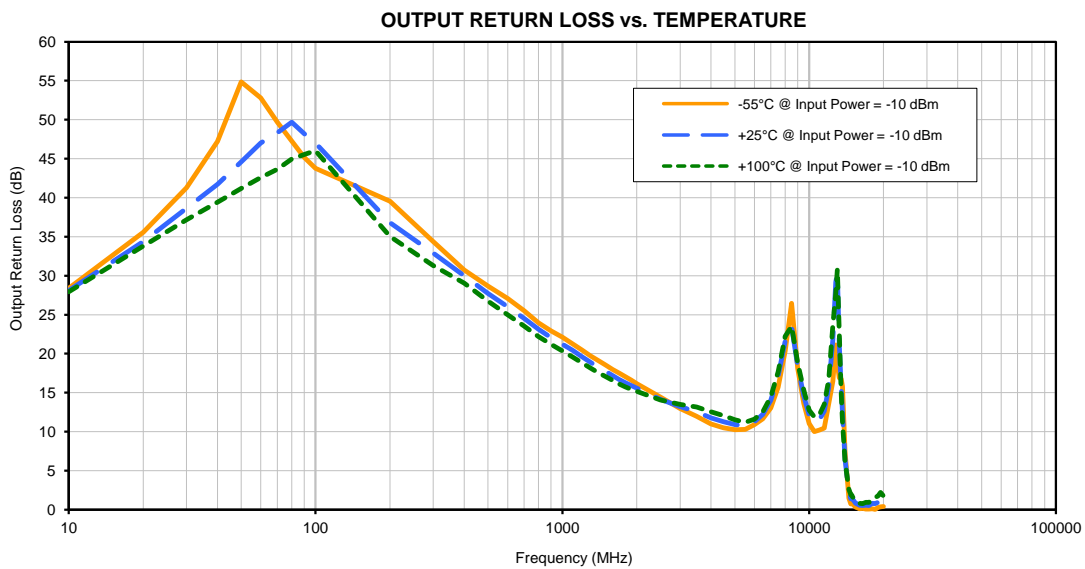
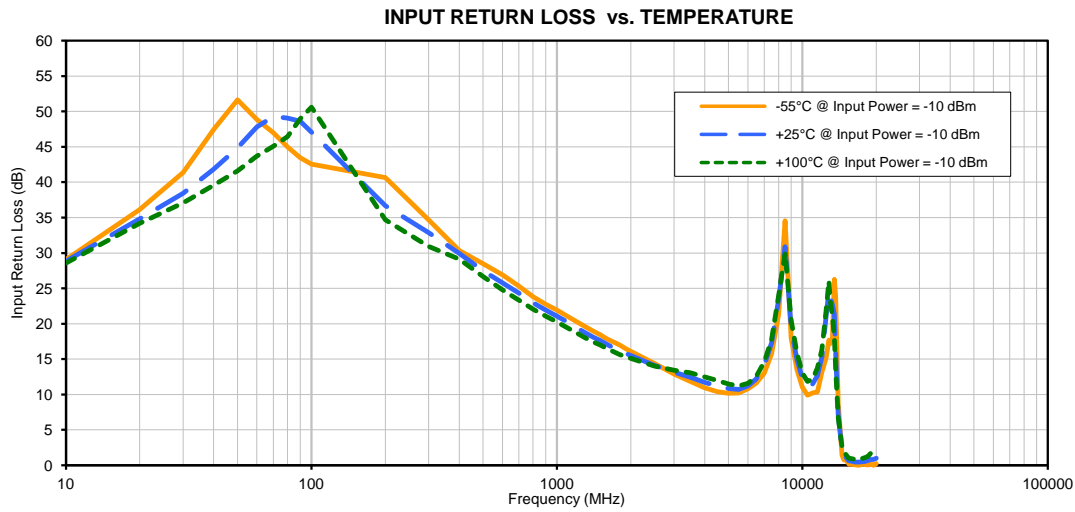
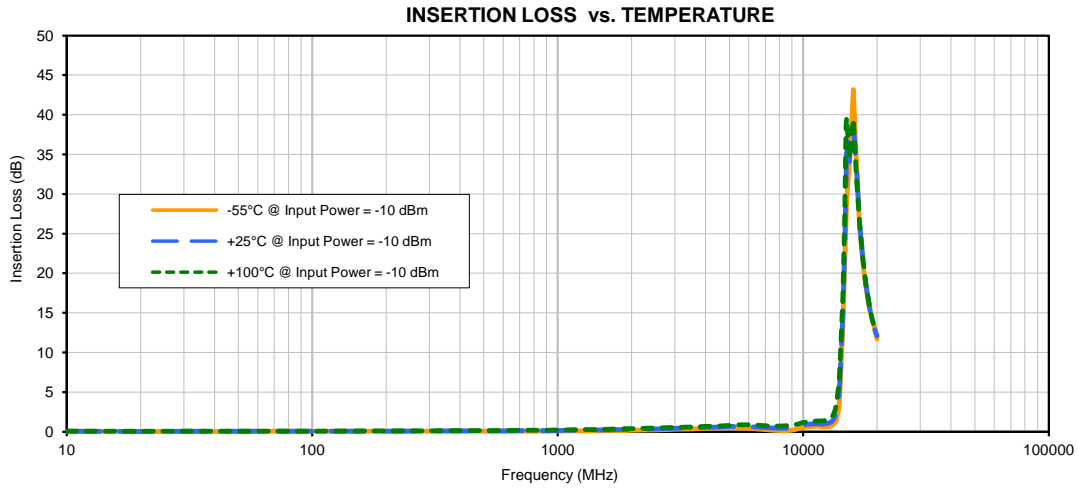

## Outline Dimensions

JC0603C-1

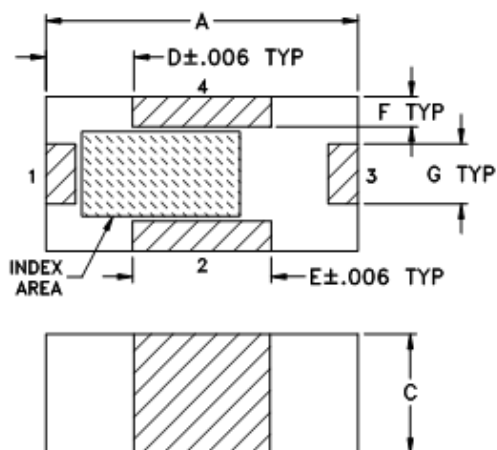

## PCB Land Pattern

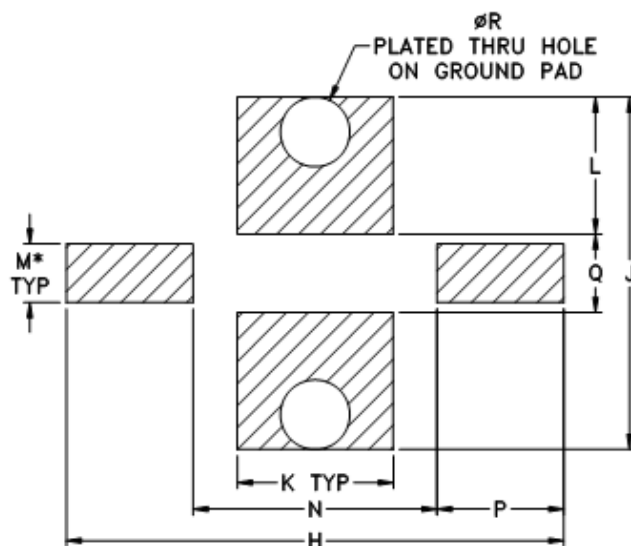

Suggested Layout,  
Tolerance to be within  $\pm .002$

CASE #	A	B	C	D	E	F	G	H	J	K	L
JC0603C-1	.063 (1.60)	.031 (0.80)	.024 (0.60)	.018 (0.45)	.028 (0.70)	.006 (0.15)	.012 (0.30)	.100 (2.54)	.071 (1.80)	.032 (0.80)	.028 (0.70)

CASE #	M*	N	P	Q	R	WT. GRAMS
JC0603C-1	.012 (0.30)	.049 (1.24)	.026 (0.65)	.016 (0.40)	.014 (0.35)	.005

Dimensions are in inches (mm). Tolerances: 3 Pl.  $\pm .004$

### Notes:

1. Open style, ceramic base.
2. Termination finish:  
For RoHS Case Styles: Tin plate over Nickel plate. All models, (+) suffix.
- 3.\* - Line width should be designed to match 50 OHMS characteristic impedance, depending on PCB material & thickness.



P.O. Box 350166, Brooklyn, New York 11235-0003 (718) 934-4500 Fax (718) 332-4661 For detailed performance specs & shopping online see Mini-Circuits web site



The Design Engineers Search Engine Provides ACTUAL Data Instantly From MINI-CIRCUITS At: [www.minicircuits.com](http://www.minicircuits.com)

RF/IF MICROWAVE COMPONENTS

# Tape & Reel Packaging TR-F114

## DEVICE ORIENTATION IN T&R



ILLUSTRATION 1

Applicable Case Styles	
GE0805C	JC0603C
GE0805C-1	JC0603C-4
GE0805C-1AP	JC0603C-6
GE0805C-7	
GE0805C-9	
GE0805C-10	
GE0805C-11	
GE0805C-12	



ILLUSTRATION 2

Applicable Case Styles	
GE0805C-2	JC0603C-1
GE0805C-3	JC0603C-2
GE0805C-4	JC0603C-3
GE0805C-5	JC0603C-5
GE0805C-6	JC0603C-7
GE0805C-8	
GE0805C-15	

Tape Width, mm	Device Cavity Pitch, mm	Reel Size, inches	Devices per Reel	
8	4	7	Small quantity standards (see note)	20
				50
				100
				200
				500
			Standard	1000
			Standard	4000

Note: Please Consult individual model data sheet to determine device per reel availability.

Mini-Circuits carrier tape materials provide protection from ESD (Electro-Static Discharge) during handling and transportation. Tapes are static dissipative and comply with industry standards EIA-481/EIA-541.

Go to: [www.minicircuits.com/pages/pdfs/tape.pdf](http://www.minicircuits.com/pages/pdfs/tape.pdf)



INTERNET <http://www.minicircuits.com>

P.O. Box 350166, Brooklyn, New York 11235-0003 (718) 934-4500 Fax (718) 332-4661

Distribution Centers NORTH AMERICA 800-654-7949 • 417-335-5935 • Fax 417-335-5945 • EUROPE 44-1252-832600 • Fax 44-1252-837010

Mini-Circuits ISO 9001 & ISO 14001 Certified

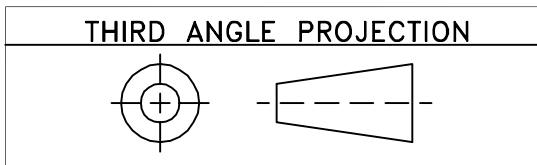

REVISIONS					
REV OR	ECN No.	DESCRIPTION	DATE	DR	AUTH
	M144975	NEW RELEASE	02/04/14	AV	RS

**SUGGESTED MOUNTING CONFIGURATION  
FOR JC0603C-1 CASE STYLE, "04FL01" PIN CODE**

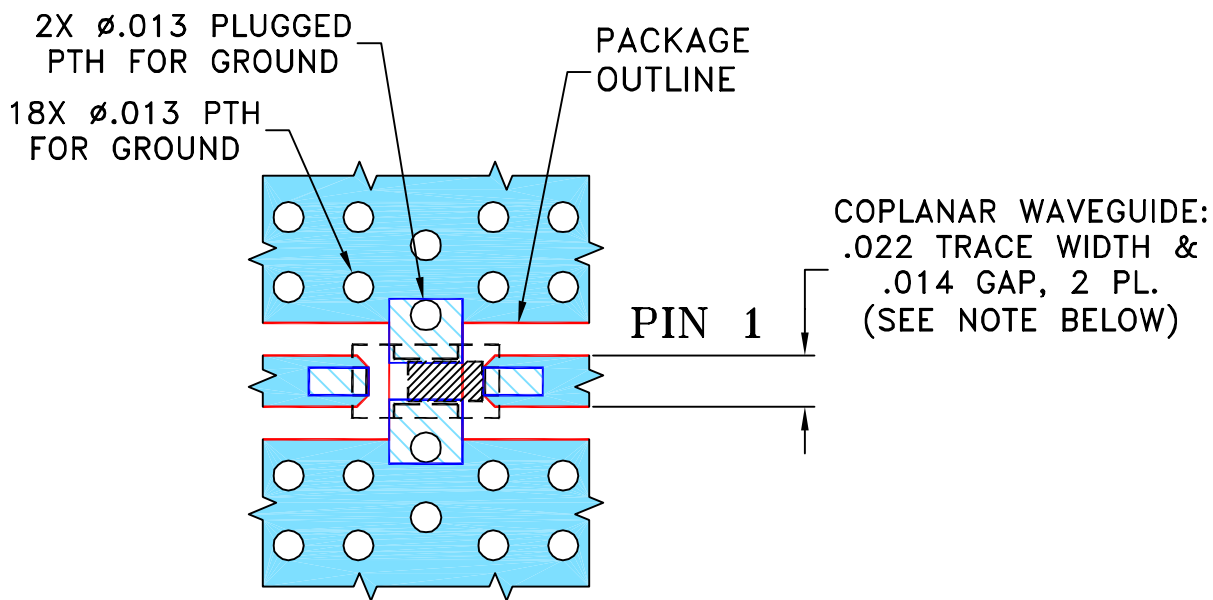

**NOTES:**

1. TRACE WIDTH IS SHOWN FOR ROGERS RO4350B WITH DIELECTRIC THICKNESS .010" ± .001". COPPER: 1/2 OZ. EACH SIDE. FOR OTHER MATERIALS TRACE WIDTH AND GAP MAY NEED TO BE MODIFIED.
2. BOTTOM SIDE OF THE PCB IS CONTINUOUS GROUND PLANE.

 DENOTES PCB COPPER LAYOUT WITH SMOBC (SOLDER MASK OVER BARE COPPER).

 DENOTES COPPER LAND PATTERN FREE OF SOLDER MASK.

UNLESS OTHERWISE SPECIFIED	INITIALS	DATE
DIMENSIONS ARE IN INCHES	DRAWN AV	01/24/14
TOLERANCES ON:	CHECKED IL	02/03/14
2 PL DECIMALS ±	APPROVED RS	02/04/14
3 PL DECIMALS ± .005		
ANGLES ±		
FRACTIONS ±		

 **Mini-Circuits®** 13 Neptune Avenue  
Brooklyn NY 11235

**PL, 04FL01, JC0603C-1, TB-720+**

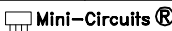
 Mini-Circuits®  
THIS DOCUMENT AND ITS CONTENTS ARE THE PROPERTY OF MINI-CIRCUITS. EXCEPT FOR USE EXPRESSLY GRANTED, IN WRITING, TO ITS VENDORS, VENDEE AND THE UNITED STATES GOVERNMENT, MINI-CIRCUITS RESERVES ALL PROPRIETARY DESIGN, USE, MANUFACTURING AND REPRODUCTION RIGHTS THERETO. THESE CONTENTS SHALL NOT BE USED, DUPLICATED OR DISCLOSED TO ANY OUTSIDE PARTY, IN WHOLE OR IN PART, WITHOUT WRITTEN PERMISSION OF MINI-CIRCUITS.

ASHEETA1.DWG REV:A DATE:01/12/95

SIZE A	CODE IDENT 15542	DRAWING NO: 98-PL-412	REV: OR
FILE: 98PL412	SCALE: 12:1	SHEET: 1 OF 1	

# Evaluation Board and Circuit

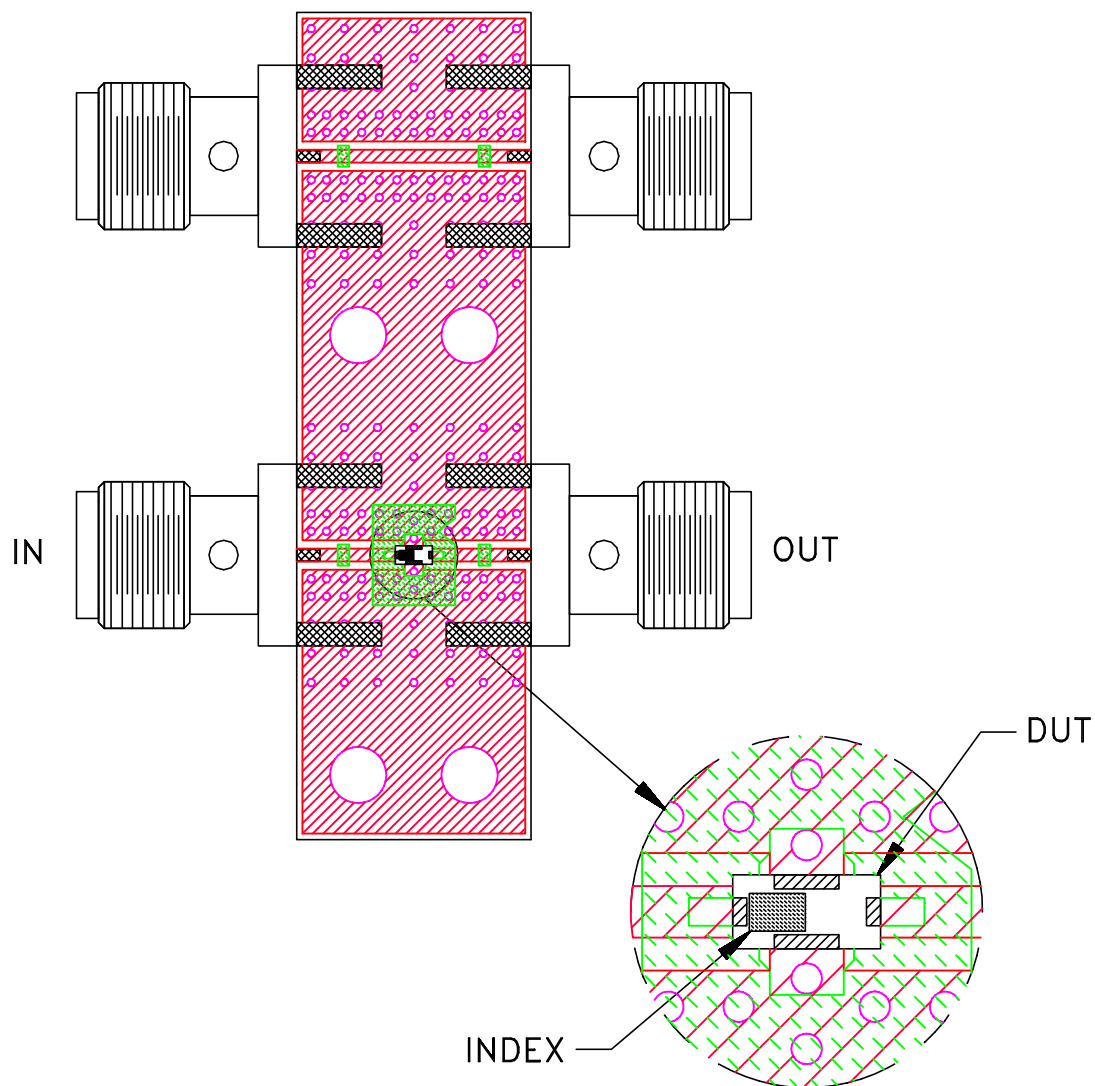

TB-720+

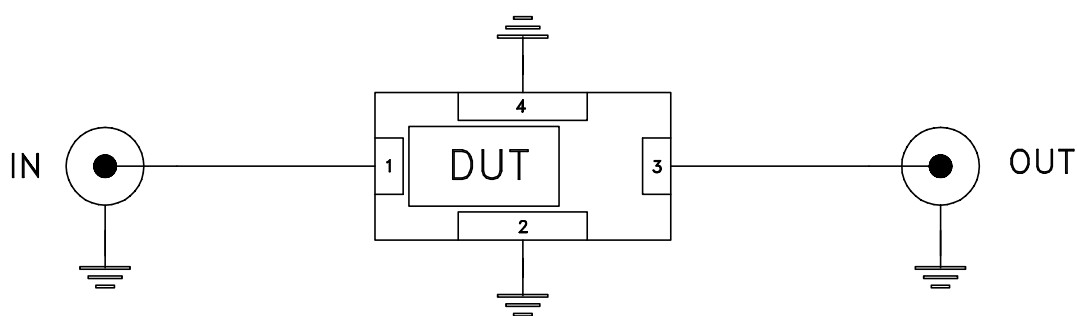

Schematic Diagram

## Notes:

1. 50 Ohm 2.92 mm End Launch Female connectors.
2. PCB Material: R04350 or equivalent, Dielectric Constant=3.5, Thickness=.010 inch.

 **Mini-Circuits®**

All Mini-Circuits products are manufactured under exacting quality assurance and control standards, and are capable of meeting published specifications after being subjected to any or all of the following physical and environmental test.

Specification	Test/Inspection Condition	Reference/Spec
Operating Temperature	-55° to 100°C Ambient Environment	Individual Model Data Sheet
Storage Temperature	-55° to 100° C Ambient Environment	Individual Model Data Sheet
Humidity	90 to 95% RH, 240 hours, 50°C	MIL-STD-202, Method 103, Condition A, Except 50°C and end-point electrical test done within 12 hours
Solder Reflow Heat	Sn-Pb Eutetic Process: 225°C peak Pb-Free Process 245° - 250°C peak	J-STD-020, Table 4-1, 4-2 and 5-2, Figure 5-1
Solderability	10X Magnification	J-STD-002, Para 4.2.5, Test S, 95% Coverage
Vibration (High Frequency)	20g peak, 10-2000 Hz, 12 times in each of three perpendicular directions (total 36)	MIL-STD-202, Method 204, Condition D
Mechanical Shock	50g, 11 ms, 1/2-sine, 18 shocks: 3 each direction, each of 3 axes	MIL-STD-202, Method 213, Condition A