

Ceramic Low Pass Filter

LFCW-5500+

50Ω DC to 5.5 GHz



Generic photo used for illustration purposes only
CASE STYLE: JC0603C-1

The Big Deal

- Very good rejection, 40 dB typical
- Rugged, ceramic construction
- Tiny size, 0.063" x 0.032" x 0.024" (0603)
- Good power handling, 2.5W

Product Overview

Mini-Circuits' LFCW-5500+ is an LTCC low pass filter with a passband from DC to 5.5 GHz, supporting a variety of applications. This model provides 1.5 dB typical passband insertion loss and provides a very good stopband rejection due to strategically constructed layout with minimal interaction between components. It handles up to 2.5W RF input power and provides a wide operating temperature range from -55 to +125°C. Housed in a tiny 0603 ceramic form factor with wraparound terminations, the filter is ideal for dense PCB layouts and with minimal performance variation due to parasitics.

Key Features

Feature	Advantages
Ultra-wide stopband	The LTCC lowpass filter provides a very good stopband rejection until 26.5 GHz suitable for high end applications.
LTCC Construction	Provides repeatable performance in a rugged, ceramic package well suited for tough environments such as high humidity and temperature extremes.
Tiny size (0.063" x 0.032" x 0.024")	Saves space in dense circuit board layouts and minimizes the effects of parasitics.
Good power handling, 2.5W	Supports a wide range of system power requirements.
Wrap-around terminations	Provides excellent solderability and easy visual inspection

Notes

- A. Performance and quality attributes and conditions not expressly stated in this specification document are intended to be excluded and do not form a part of this specification document.
B. Electrical specifications and performance data contained in this specification document are based on Mini-Circuit's applicable established test performance criteria and measurement instructions.
C. The parts covered by this specification document are subject to Mini-Circuits standard limited warranty and terms and conditions (collectively, "Standard Terms"); Purchasers of this part are entitled to the rights and benefits contained therein. For a full statement of the Standard Terms and the exclusive rights and remedies thereunder, please visit Mini-Circuits' website at www.minicircuits.com/MCLStore/terms.jsp



Low Pass Filter

LFCW-5500+

50Ω DC to 5.5 GHz



Generic photo used for illustration purposes only
CASE STYLE: JC0603C-1

+RoHS Compliant
The +Suffix identifies RoHS Compliance. See our web site for RoHS Compliance methodologies and qualifications

Features

- Low loss, 1.5 dB typical
- Good rejection 40 dB typical
- Extremely small size 0603 (0.063" X 0.032" X 0.024")
- Temperature stable
- LTCC construction

Applications

- Military radios
- 5G Sub 6 GHz
- Point-Point communication

Electrical Specifications^{1,2} at 25°C

Parameter	F#	Frequency (MHz)	Min.	Typ.	Max.	Unit	
Pass Band	Insertion Loss	DC-F1	DC - 5500	—	1.5	2	dB
	Freq. Cut-Off	F2*	6320	—	3.0	—	dB
	Return Loss	DC-F1	DC - 5500	—	11	—	dB
Stop Band	Rejection Loss	F3-F4	7500 - 8100	20	32	—	dB
		F4-F5	8100 - 11500	30	40	—	dB
		F5-F6	11500 - 17000	28	36	—	dB
		F6-F7	17000 - 26500	—	20	—	dB

1 DC de-coupling capacitors are required in Applications where DC voltage and/or current is present at either input or output ports. Please contact Mini-Circuits for alternatives if DC pass from IN-OUT is required.

2 Measured on Mini-Circuits Characterization Test Board TB-LFCW-5500+

* Typically, a ±5% frequency deviation from the stated value may occur on a unit-to-unit basis.

Functional Schematic

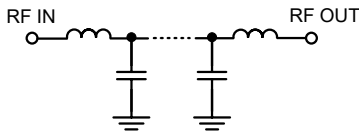

Maximum Ratings

Operating Temperature	-55°C to 125°C
Storage Temperature	-55°C to 125°C
RF Power Input*	2.5 W @25°C

*Passband rating, derate linearly to 0.7 W at 125°C ambient
Permanent damage may occur if any of these limits are exceeded.

Typical Performance Data at 25°C

Frequency (MHz)	Insertion Loss (dB)	Return Loss (dB)
10	0.09	46.36
100	0.11	36.54
500	0.22	27.81
1000	0.29	24.77
2000	0.42	19.23
3000	0.56	17.30
5000	0.90	25.23
5500	1.15	22.17
6320	2.32	14.97
6495	3.16	13.72
7050	22.46	1.60
7500	37.70	1.02
8100	41.29	0.78
8600	53.26	0.68
9300	50.75	0.58
11500	52.58	0.39
14000	48.37	0.52
17000	40.91	0.35
20000	29.88	0.42
26500	29.58	0.39

Typical Frequency Response

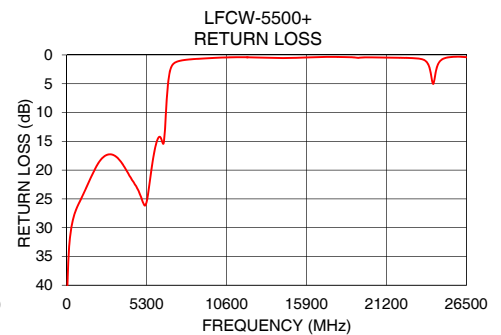
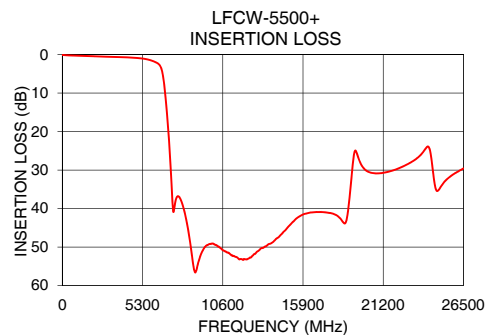
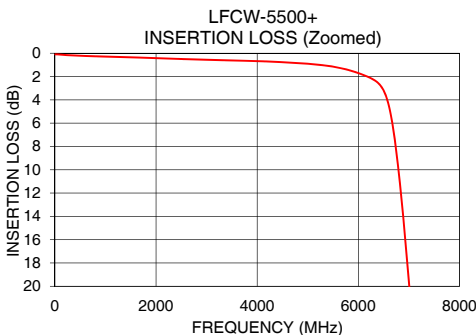
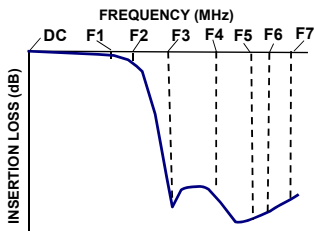

Notes

- Performance and quality attributes and conditions not expressly stated in this specification document are intended to be excluded and do not form a part of this specification document.
- Electrical specifications and performance data contained in this specification document are based on Mini-Circuit's applicable established test performance criteria and measurement instructions.
- The parts covered by this specification document are subject to Mini-Circuits standard limited warranty and terms and conditions (collectively, "Standard Terms"); Purchasers of this part are entitled to the rights and benefits contained therein. For a full statement of the Standard Terms and the exclusive rights and remedies thereunder, please visit Mini-Circuits' website at www.minicircuits.com/MCLStore/terms.jsp



Pad Connections

INPUT	1
OUTPUT	3
GROUND	2, 4

Product Marking: O

Demo Board MCL P/N: TB-LFCW-5500+
Suggested PCB Layout (PL-650)

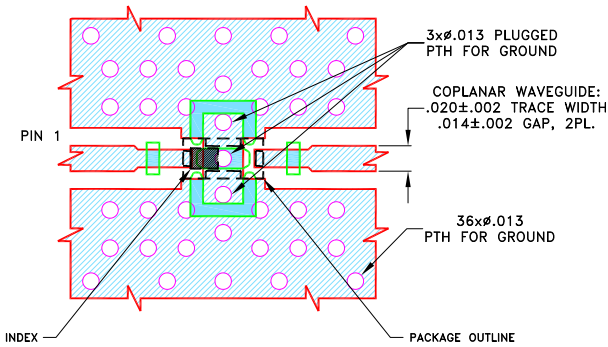

- NOTES:
1. COPLANAR WAVEGUIDE PARAMETERS ARE SHOWN FOR ROGERS (R04835 Lo Pro) WITH DIELECTRIC THICKNESS .0107±.0010. COPPER: 1/2 Oz. EACH SIDE. FOR OTHER MATERIALS TRACE WIDTH AND GAP MAY NEED TO BE MODIFIED.
 2. BOTTOM SIDE OF THE PCB IS CONTINUOUS GROUND PLANE.
- DENOTES PCB COPPER LAYOUT WITH SMOBC (SOLDER MASK OVER BARE COPPER)
■ DENOTES COPPER LAND PATTERN FREE OF SOLDERMASK

Outline Drawing

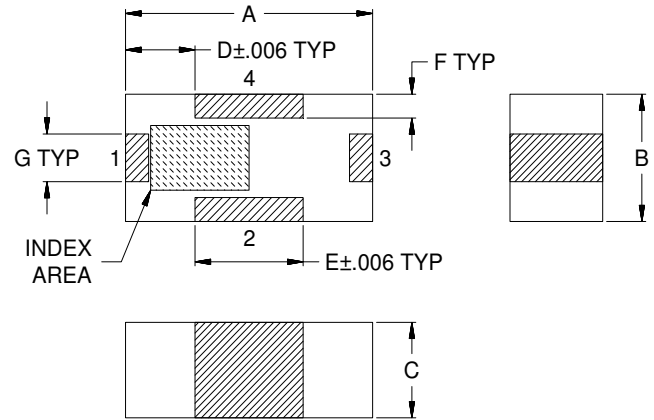

Outline Dimensions (Inch / mm)

A	B	C	D	E	F	G	Wt.
.063	.032	.024	.018	.028	.006	.012	grams
1.60	0.80	0.60	0.45	0.70	0.15	0.30	.005

Note: Please refer to case style drawing for details

Notes

- A. Performance and quality attributes and conditions not expressly stated in this specification document are intended to be excluded and do not form a part of this specification document.
 B. Electrical specifications and performance data contained in this specification document are based on Mini-Circuit's applicable established test performance criteria and measurement instructions.
 C. The parts covered by this specification document are subject to Mini-Circuits standard limited warranty and terms and conditions (collectively, "Standard Terms"); Purchasers of this part are entitled to the rights and benefits contained therein. For a full statement of the Standard Terms and the exclusive rights and remedies thereunder, please visit Mini-Circuits' website at www.minicircuits.com/MCLStore/terms.jsp

Typical Performance Data

FREQ. (MHz)	INSERTION LOSS			INPUT RETURN LOSS			OUTPUT RETURN LOSS		
	(dB)			(dB)			(dB)		
	@-55°C	@+25°C	@+125°C	@-55°C	@+25°C	@+125°C	@-55°C	@+25°C	@+125°C
10	0.08	0.09	0.11	40.89	44.17	41.05	40.74	43.97	41.50
100	0.09	0.11	0.15	42.14	36.78	34.49	42.69	36.84	34.24
200	0.12	0.14	0.19	29.06	32.30	31.28	29.20	32.18	31.03
250	0.13	0.15	0.21	26.89	31.12	30.59	26.85	30.86	30.17
300	0.13	0.16	0.23	26.37	30.19	29.92	26.26	29.77	29.18
350	0.14	0.17	0.24	26.92	29.39	29.40	26.62	28.92	28.66
400	0.14	0.18	0.25	27.74	28.71	28.95	27.23	28.16	27.81
500	0.15	0.20	0.28	28.23	27.82	28.15	27.26	26.91	26.73
550	0.16	0.21	0.28	27.49	27.39	27.72	26.49	26.34	26.20
600	0.16	0.22	0.29	26.72	27.04	27.45	25.72	25.89	25.82
650	0.17	0.23	0.30	26.21	26.66	27.24	25.13	25.41	25.43
700	0.17	0.23	0.31	26.11	26.41	26.96	24.90	25.05	25.15
750	0.18	0.24	0.32	25.96	26.12	26.81	24.66	24.68	24.83
800	0.18	0.25	0.32	25.88	25.80	26.57	24.41	24.30	24.52
850	0.19	0.25	0.33	25.67	25.59	26.42	24.13	24.00	24.28
1000	0.20	0.27	0.35	23.68	24.68	25.70	22.52	23.06	23.49
1200	0.22	0.29	0.38	21.95	23.54	24.47	20.97	22.04	22.55
1500	0.25	0.33	0.42	20.66	21.67	22.55	20.05	20.74	21.42
2000	0.29	0.40	0.49	18.89	19.06	19.73	19.24	19.27	19.93
2500	0.34	0.47	0.56	17.63	17.52	18.04	18.83	18.52	19.03
3000	0.40	0.53	0.63	16.90	17.32	17.72	18.12	18.49	18.85
3400	0.43	0.57	0.68	17.62	18.08	18.44	18.74	18.88	19.19
4000	0.47	0.64	0.78	20.16	20.22	20.46	20.09	19.84	20.16
5000	0.65	0.86	1.06	21.91	25.49	24.66	23.73	29.63	29.93
5100	0.68	0.90	1.10	22.59	26.35	25.34	25.19	32.87	33.32
5500	0.82	1.11	1.37	23.97	22.59	20.50	26.85	23.23	21.27
6020	1.30	1.71	2.11	14.61	14.82	13.94	15.67	15.89	15.03
6320	1.76	2.29	2.90	13.39	15.19	15.50	15.71	19.40	22.60
6495	2.22	3.16	4.40	14.49	14.01	10.87	24.57	23.63	14.54
6520	2.33	3.40	4.81	14.42	12.99	9.70	29.98	19.89	12.70
6910	10.94	15.15	19.27	2.49	2.26	2.14	3.77	3.46	3.28
7200	25.80	32.29	37.78	1.04	1.29	1.46	1.86	2.17	2.39
7300	32.86	39.32	39.27	0.90	1.16	1.37	1.63	1.96	2.20
7500	40.31	37.62	36.34	0.75	0.98	1.22	1.35	1.67	1.91
7590	37.95	36.80	36.28	0.70	0.93	1.18	1.25	1.55	1.78
7600	37.77	36.76	36.31	0.70	0.92	1.17	1.24	1.54	1.77
7700	36.80	36.80	36.85	0.66	0.87	1.12	1.14	1.43	1.64
7800	36.79	37.39	37.79	0.61	0.83	1.07	1.05	1.33	1.51
7900	37.36	38.38	39.05	0.58	0.79	1.04	0.99	1.26	1.41
8000	38.32	39.66	40.54	0.56	0.76	1.01	0.93	1.19	1.31
8100	39.78	41.54	42.37	0.54	0.73	0.97	0.89	1.12	1.22
8150	40.34	42.20	43.37	0.52	0.72	0.95	0.87	1.08	1.18
8200	41.07	43.04	44.56	0.52	0.71	0.94	0.85	1.06	1.15
8600	49.98	53.13	54.32	0.47	0.64	0.83	0.69	0.89	0.93
8700	52.74	55.03	55.38	0.46	0.62	0.82	0.65	0.85	0.89
8800	55.05	55.75	56.19	0.45	0.61	0.79	0.61	0.82	0.85
9000	55.58	54.03	52.09	0.41	0.59	0.76	0.55	0.77	0.81
9300	52.49	50.88	50.56	0.37	0.57	0.71	0.44	0.70	0.76
9800	49.78	49.62	48.75	0.30	0.54	0.66	0.29	0.61	0.73
10000	49.66	49.00	48.89	0.26	0.53	0.64	0.25	0.58	0.72
11500	51.59	52.04	52.20	0.16	0.42	0.64	0.24	0.47	0.59
14300	46.79	46.56	47.67	0.14	0.39	0.54	0.00	0.39	0.45
15000	43.39	43.84	44.44	0.18	0.41	0.54	0.01	0.33	0.55
15400	41.66	42.31	43.21	0.19	0.43	0.54	0.01	0.31	0.61
15700	41.19	41.85	42.59	0.16	0.42	0.58	0.01	0.29	0.66
16000	40.75	41.71	42.18	0.11	0.42	0.62	0.02	0.27	0.67
17000	41.00	40.84	40.86	0.04	0.39	0.72	0.01	0.29	0.64
18300	42.13	42.46	42.80	0.04	0.36	0.73	0.09	0.43	0.52
20000	27.51	29.31	29.89	0.08	0.38	0.51	0.08	0.41	0.43
26500	29.62	29.58	28.64	0.36	0.39	0.90	0.04	0.35	1.14

Typical Performance Data

FREQ. (MHz)	GROUP DELAY		
	(nsec)		
	@-55°C	@+25°C	@+125°C
10	0.09	0.11	0.15
50	0.10	0.11	0.13
100	0.11	0.10	0.11
150	0.11	0.10	0.11
200	0.11	0.10	0.10
250	0.11	0.10	0.10
300	0.11	0.10	0.10
350	0.11	0.10	0.10
400	0.11	0.10	0.10
450	0.11	0.10	0.10
500	0.11	0.10	0.10
550	0.11	0.10	0.10
1000	0.11	0.10	0.10
1150	0.11	0.10	0.10
1300	0.11	0.10	0.10
1450	0.11	0.10	0.10
1600	0.11	0.10	0.10
1750	0.12	0.10	0.11
1900	0.12	0.10	0.11
2050	0.12	0.10	0.11
2200	0.12	0.11	0.11
2350	0.12	0.11	0.11
2500	0.12	0.11	0.11
2650	0.12	0.11	0.11
2800	0.13	0.11	0.12
2950	0.13	0.12	0.12
3100	0.13	0.12	0.12
3250	0.13	0.12	0.13
3400	0.14	0.12	0.13
3550	0.14	0.13	0.13
3600	0.14	0.13	0.13
3700	0.14	0.13	0.14
3800	0.15	0.14	0.14
4000	0.15	0.14	0.15
4100	0.16	0.15	0.15
4200	0.16	0.15	0.15
4300	0.16	0.15	0.16
4500	0.17	0.16	0.17
5000	0.20	0.19	0.20
5100	0.21	0.20	0.21
5500	0.25	0.24	0.25

Typical Performance Curves

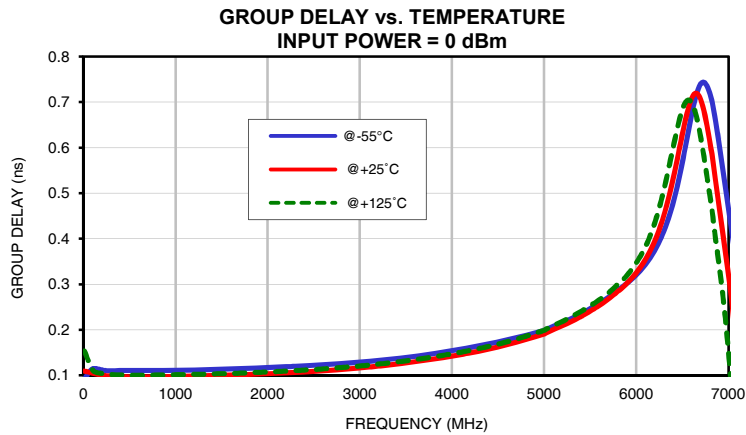
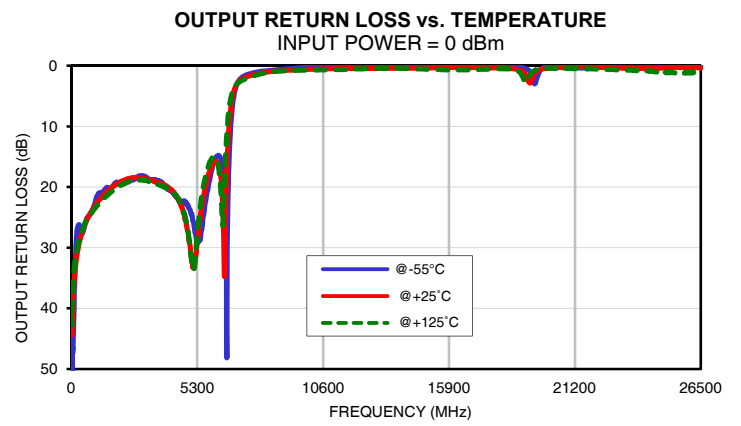
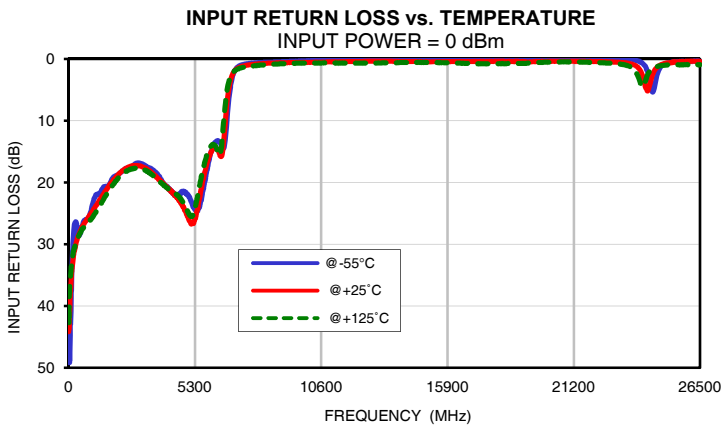
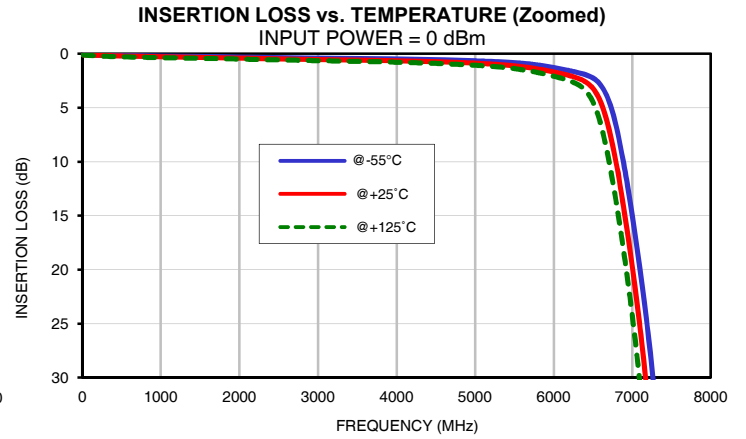
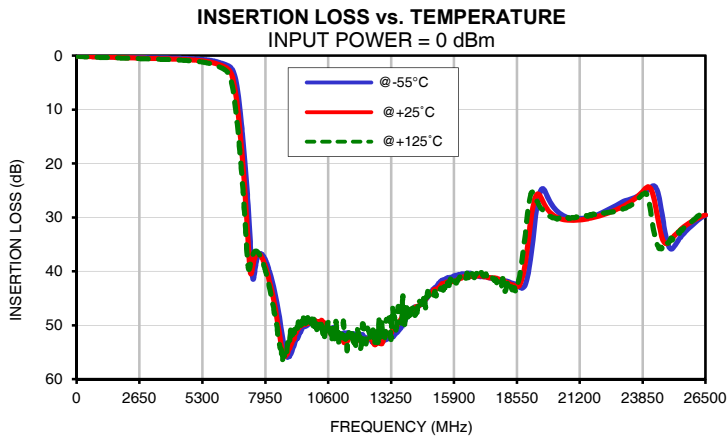

Outline Dimensions

JC0603C-1

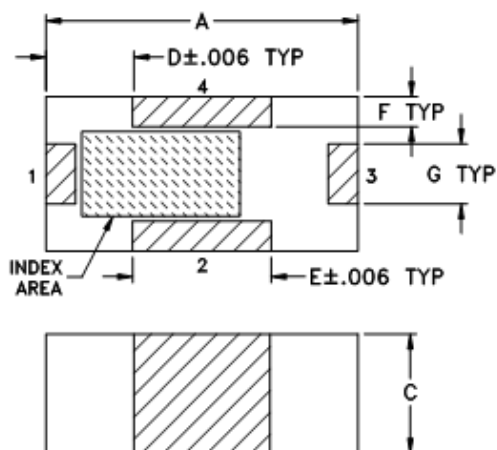

PCB Land Pattern

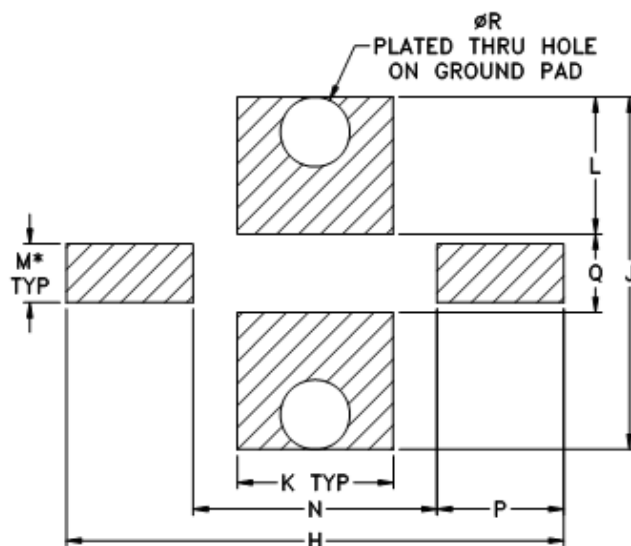

Suggested Layout,
Tolerance to be within $\pm .002$

CASE #	A	B	C	D	E	F	G	H	J	K	L
JC0603C-1	.063 (1.60)	.031 (0.80)	.024 (0.60)	.018 (0.45)	.028 (0.70)	.006 (0.15)	.012 (0.30)	.100 (2.54)	.071 (1.80)	.032 (0.80)	.028 (0.70)

CASE #	M*	N	P	Q	R	WT. GRAMS
JC0603C-1	.012 (0.30)	.049 (1.24)	.026 (0.65)	.016 (0.40)	.014 (0.35)	.005

Dimensions are in inches (mm). Tolerances: 3 Pl. $\pm .004$

Notes:

1. Open style, ceramic base.
2. Termination finish:
For RoHS Case Styles: Tin plate over Nickel plate. All models, (+) suffix.
- 3.* - Line width should be designed to match 50 OHMS characteristic impedance, depending on PCB material & thickness.



P.O. Box 350166, Brooklyn, New York 11235-0003 (718) 934-4500 Fax (718) 332-4661 For detailed performance specs & shopping online see Mini-Circuits web site



The Design Engineers Search Engine Provides ACTUAL Data Instantly From MINI-CIRCUITS At: www.minicircuits.com

RF/MICROWAVE COMPONENTS

Tape & Reel Packaging TR-F114

DEVICE ORIENTATION IN T&R



ILLUSTRATION 1

Applicable Case Styles	
GE0805C	JC0603C
GE0805C-1	JC0603C-4
GE0805C-1AP	JC0603C-6
GE0805C-7	
GE0805C-9	
GE0805C-10	
GE0805C-11	
GE0805C-12	



ILLUSTRATION 2

Applicable Case Styles	
GE0805C-2	JC0603C-1
GE0805C-3	JC0603C-2
GE0805C-4	JC0603C-3
GE0805C-5	JC0603C-5
GE0805C-6	JC0603C-7
GE0805C-8	
GE0805C-15	

Tape Width, mm	Device Cavity Pitch, mm	Reel Size, inches	Devices per Reel	
8	4	7	Small quantity standards (see note)	20
				50
				100
				200
				500
			Standard	1000
			Standard	4000

Note: Please Consult individual model data sheet to determine device per reel availability.

Mini-Circuits carrier tape materials provide protection from ESD (Electro-Static Discharge) during handling and transportation. Tapes are static dissipative and comply with industry standards EIA-481/EIA-541.

Go to: www.minicircuits.com/pages/pdfs/tape.pdf



INTERNET <http://www.minicircuits.com>

P.O. Box 350166, Brooklyn, New York 11235-0003 (718) 934-4500 Fax (718) 332-4661

Distribution Centers NORTH AMERICA 800-654-7949 • 417-335-5935 • Fax 417-335-5945 • EUROPE 44-1252-832600 • Fax 44-1252-837010

Mini-Circuits ISO 9001 & ISO 14001 Certified

THIRD ANGLE PROJECTION

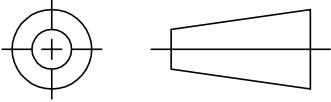

REVISIONS

REV	ECN No.	DESCRIPTION	DATE	DR	AUTH
OR	M175765	NEW RELEASE	AUG 19	DDR	VC
A	M175661	DESIGN CHANGED	NOV 19	DDR	VC

**SUGGESTED MOUNTING CONFIGURATION
FOR JC0603C-1 CASE STYLE**

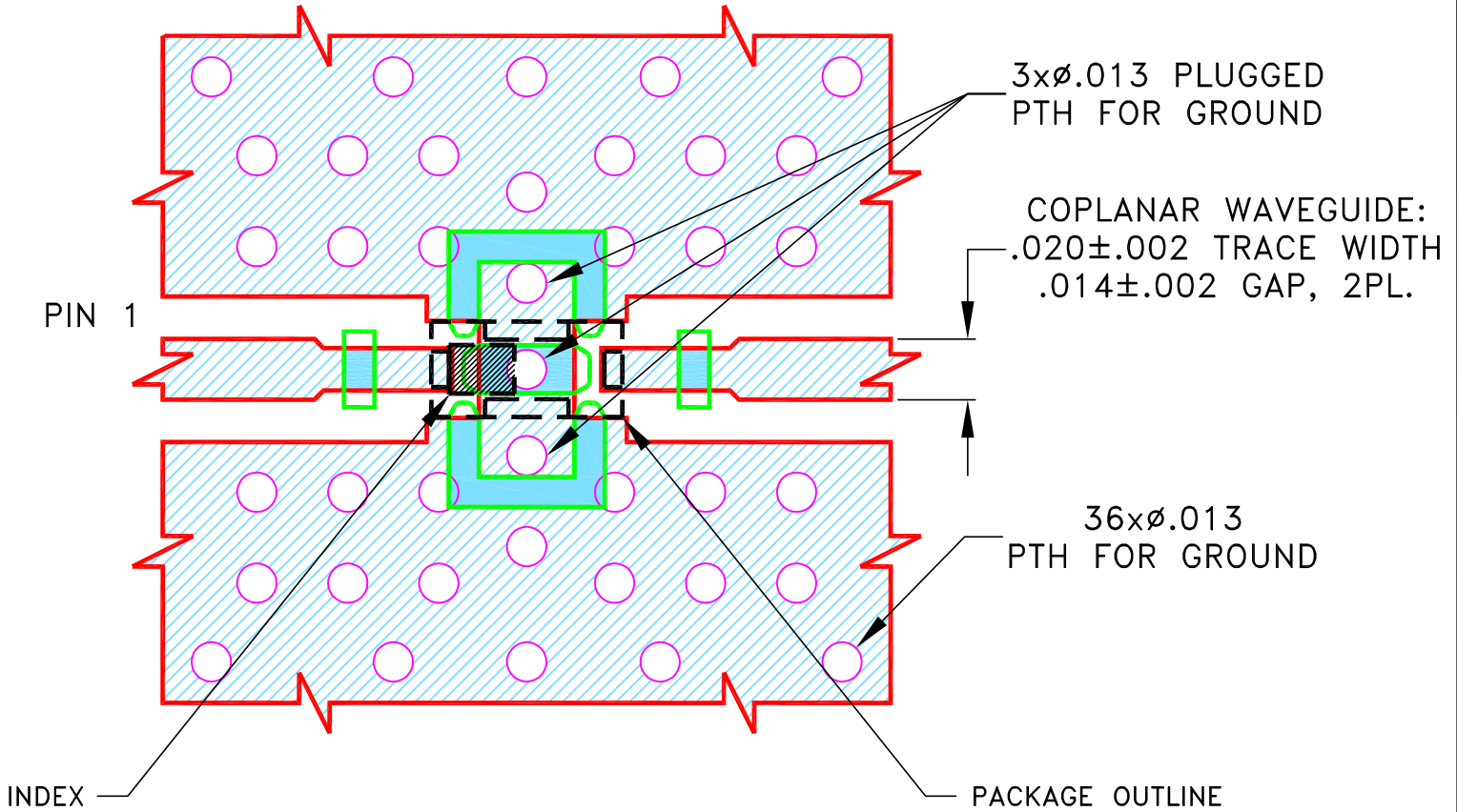

NOTES:

- COPLANAR WAVEGUIDE PARAMETERS ARE SHOWN FOR ROGERS (R04835 Lo Pro) WITH DIELECTRIC THICKNESS .0107 \pm .0010. COPPER: 1/2 Oz. EACH SIDE. FOR OTHER MATERIALS TRACE WIDTH AND GAP MAY NEED TO BE MODIFIED.
- BOTTOM SIDE OF THE PCB IS CONTINUOUS GROUND PLANE.

- DENOTES PCB COPPER LAYOUT WITH SMOBC (SOLDER MASK OVER BARE COPPER)
- DENOTES COPPER LAND PATTERN FREE OF SOLDERMASK

UNLESS OTHERWISE SPECIFIED	INITIALS	DATE
DIMENSIONS ARE IN INCHES	DRAWN DDR	05 AUG 19
TOLERANCES ON:	CHECKED RV	05 AUG 19
2 PL DECIMALS \pm	APPROVED RKS	05 AUG 19
3 PL DECIMALS \pm .005		
ANGLES \pm		
FRACTIONS \pm		

Mini-Circuits[®] 13 Neptune Avenue
Brooklyn NY 11235

PL, JC0603C-1, TB-1114+

Mini-Circuits[®]
THIS DOCUMENT AND ITS CONTENTS ARE THE PROPERTY OF MINI-CIRCUITS. EXCEPT FOR USE EXPRESSLY GRANTED, IN WRITING, TO ITS VENDORS, VENDEE AND THE UNITED STATES GOVERNMENT, MINI-CIRCUITS RESERVES ALL PROPRIETARY DESIGN, USE, MANUFACTURING AND REPRODUCTION RIGHTS THERETO. THESE CONTENTS SHALL NOT BE USED, DUPLICATED OR DISCLOSED TO ANY OUTSIDE PARTY, IN WHOLE OR IN PART, WITHOUT WRITTEN PERMISSION OF MINI-CIRCUITS.

SIZE	CODE IDENT	DRAWING NO:	REV:
A	15542	98-PL-650	A
FILE:	98PL650	SCALE:	SHEET:
		16:1	1 OF 1

Evaluation Board and Circuit

TB-LFCW-5500+

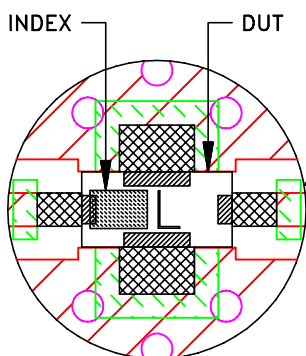
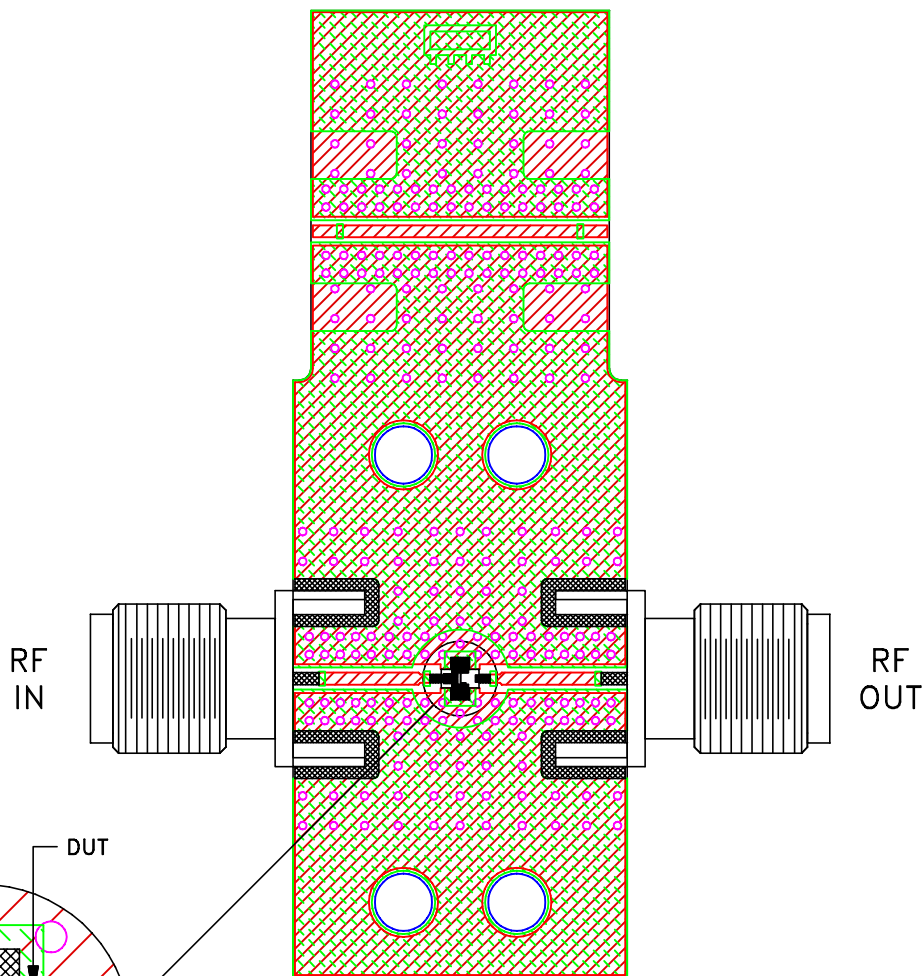

Schematic diagram

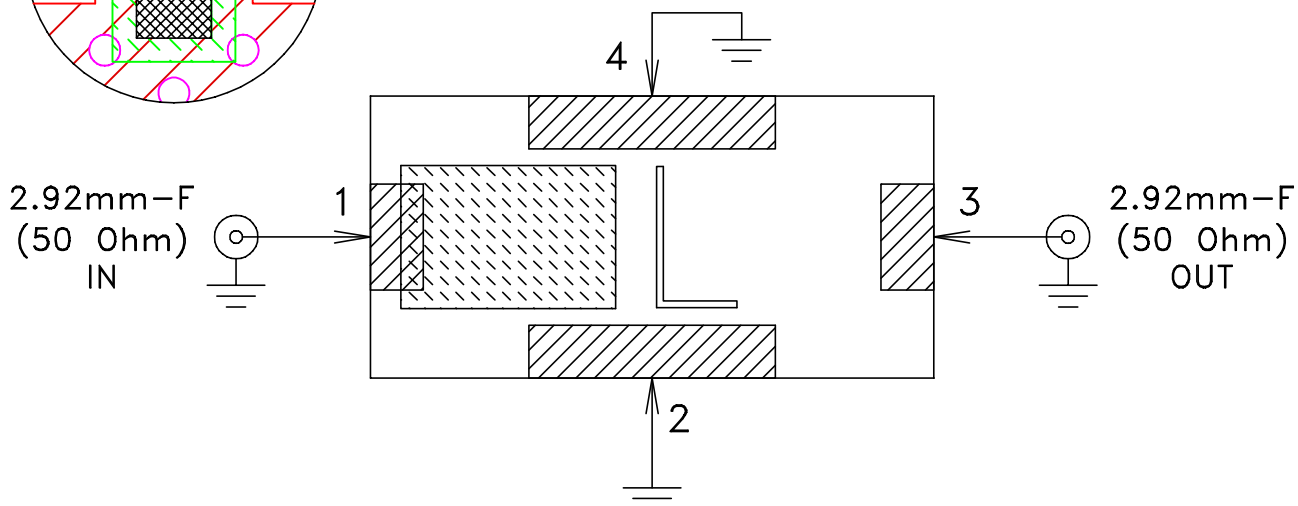

Notes:

1. PCB Material: ROGERS (RO4835 Lo Pro) OR Equivalent, Dielectric Constant= 3.48 ± 0.05
Dielectric Thickness: $.0107 \pm .0010$
2. 50 Ohm 2.92mm Female Connectors.
3. Connectors on the test board shall not be subjected to temperature greater than 200°C to avoid permanent damage to the connectors.

 **Mini-Circuits®**

All Mini-Circuits products are manufactured under exacting quality assurance and control standards, and are capable of meeting published specifications after being subjected to any or all of the following physical and environmental test.

Specification	Test/Inspection Condition	Reference/Spec
Operating Temperature	-55° to 125° C Ambient Environment	Individual Model Data Sheet
Storage Temperature	-55° to 125° C Ambient Environment	Individual Model Data Sheet
Humidity	90 to 95% RH, 240 hours, 50°C	MIL-STD-202, Method 103, Condition A, Except 50°C and end-point electrical test done within 12 hours
Solder Reflow Heat	Sn-Pb Eutectic Process 225°C peak Pb-Free Process 245° - 250°C peak	J-STD-020C, Table 4-1, 4-2 and 5-2, Figure 5-1
Solderability	10X Magnification	J-STD-002, Para 4.2.5, Test S, 95% Coverage
Vibration (High Frequency)	20g peak, 10-2000 Hz, 12 times in each of three perpendicular directions (total 36)	MIL-STD-202, Method 204, Condition D
Mechanical Shock	50g, 11 ms, 1/2-sine, 18 shocks: 3 each direction, each of 3 axes	MIL-STD-202, Method 213, Condition A