



ULTRA HIGH DYNAMIC RANGE

Monolithic Amplifier

LHA-23HLN+

50Ω 30 MHz to 2 GHz

THE BIG DEAL

- Ultra-High IP3, +44.7 dBm typ.
- Gain, 21.5 dB typ. at 1 GHz
- Medium power, +28.3 dBm typ.
- Excellent Noise Figure, 1.3 dB typ.

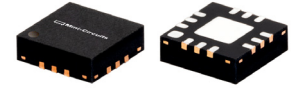

Generic photo used for illustration purposes only

CASE STYLE: DQ1225

+RoHS Compliant

The +Suffix identifies RoHS Compliance. See our website for methodologies and qualifications

APPLICATIONS

- Base station infrastructure
- CATV
- Cellular

PRODUCT OVERVIEW

LHA-23HLN+ (RoHS compliant) is an advanced wideband amplifier fabricated using E-PHEMT technology and offers extremely high dynamic range over a broad frequency range and with low noise figure. In addition, the LHA-23HLN+ has good input and output return loss over a broad frequency range. LHA-23HLN+ is enclosed in a 3mm x 3mm, 12-lead MCLP package and has very good thermal performance.

KEY FEATURES

Feature	Advantages
Broad Band: 30 MHz to 2 GHz	Broadband covering primary wireless communications bands: VHF, UHF, Cellular
Extremely High IP3 +43.8 dBm typical at 0.5 GHz +44.7 dBm typical at 1GHz	The LHA-23HLN+ matches industry leading IP3 performance relative to device size and power consumption. The combination of the design and E-PHEMT Structure provides enhanced linearity over a broad frequency range as evidence in the IP3 being approximately 11-17 dB above the P1dB point. This feature makes this amplifier ideal for use in: <ul style="list-style-type: none"> • Driver amplifiers for complex waveform up converter paths • Drivers in linearized transmit systems • Secondary amplifiers in ultra-High Dynamic range receivers
Low Noise Figure 1.3 dB at 1 GHz	Enables lower system noise figure performance and along with High OIP3 provides high dynamic range
High P1dB, +28.3 dBm at 1 GHz	High P1dB, High OIP3, Low NF results in a very dynamic range preventing amplifier saturation under strong interfering signals.

REV. A
ECO-011665
LHA-23HLN+
MCL NY
240725





ULTRA HIGH DYNAMIC RANGE

Monolithic Amplifier

LHA-23HLN+

50Ω 30 MHz to 2 GHz

ELECTRICAL SPECIFICATIONS¹ AT +25°C, 50Ω, UNLESS NOTED OTHERWISE

Parameter	Condition (GHz)	Vd=+8V ¹			Units
		Min.	Typ.	Max.	
Frequency Range		30		2000	MHz
Gain	30	—	23.2	—	dB
	500	—	22.1	—	
	1000	19.2	21.5	23.5	
	1500	18.5	20.9	22.6	
	2000	—	20.2	—	
Input Return Loss	30		12		dB
	500		11		
	1000		10		
	1500		10		
	2000		11		
Output Return Loss	30		14		dB
	500		13		
	1000		14		
	1500		12		
	2000		10		
Reverse Isolation	1000		27.2		dB
Output Power @1 dB compression	30		+26.0		dBm
	500		+28.3		
	1000		+28.3		
	1500		+28.0		
	2000		+27.9		
Output IP3 ²	30		+41.1		dBm
	500		+43.8		
	1000		+44.7		
	1500		+45.6		
	2000		+45.2		
Noise Figure	30		1.3		dB
	500		1.2		
	1000		1.3		
	1500		1.5		
	2000		1.7		
Device Operating Voltage			+8		V
Device Operating Current			244	273	mA
Device Current Variation vs. Temperature ³			-241		μA/°C
Device Current Variation vs Voltage			0.0286		mA/mV
Thermal Resistance, junction-to-ground lead Junction-to-ground lead at 85°C stage temperature			23.3		°C/W

1. Measured on Mini-Circuits Characterization test board TB-1061-23HLN+. See Characterization Test Circuit (Fig. 1)

2. Tested at P_{OUT} = 0 dBm / tone.

3. (Current at 95°C – Current at -45°C)/140

ABSOLUTE MAXIMUM RATINGS⁴

Parameter	Ratings
Operating Temperature (ground lead)	-40°C to +95°C
Storage Temperature	-65°C to +150°C
Power Dissipation ⁵	3.3 W
Input Power (CW)	+22 dBm (5 minutes max) ⁶ +11 dBm (continuous) for 0.03-1GHz +18 dBm (continuous) for 1-2 GHz
DC Voltage on Pin ⁷	+10 V

4. Permanent damage may occur if any of these limits are exceeded.

Electrical maximum ratings are not intended for continuous normal operation.

5. Up to 85°C, derate linearly to 3W at 95°C.

6. Up to 85°C, derate linearly to +19dBm at 95°C.





ULTRA HIGH DYNAMIC RANGE

Monolithic Amplifier

LHA-23HLN+

50Ω 30 MHz to 2 GHz

SIMPLIFIED SCHEMATIC AND PAD DESCRIPTION

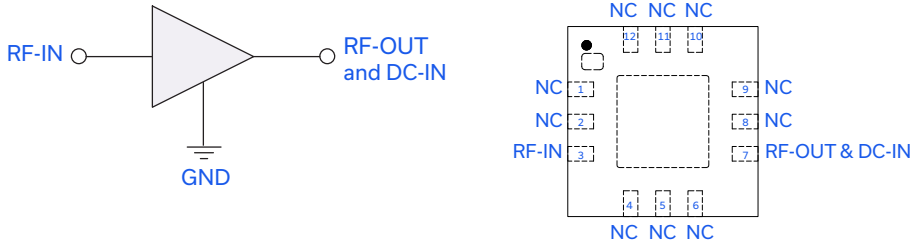

Function	Pad Number	Description
RF-IN	3	RF Input
RF-OUT and DC-IN	7	RF Output and DC Bias
GND	Paddle	Connections to ground.
NC	1-2, 4-6, 8-12	No connection, grounded externally

CHARACTERIZATION TEST / RECOMMENDED APPLICATION CIRCUIT

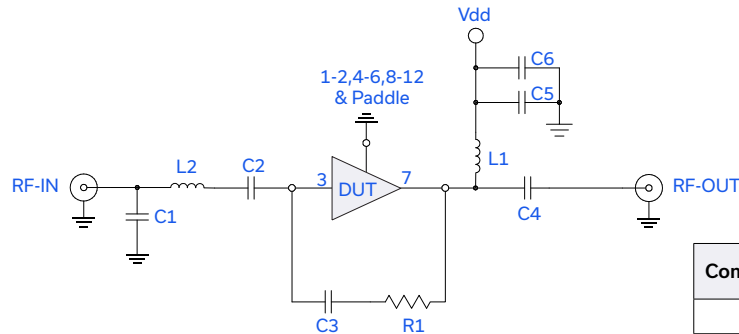
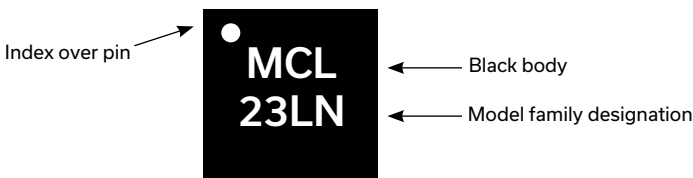

Fig 1. Block Diagram of Test Circuit used for characterization. (DUT soldered on Mini-Circuits Characterization test board TB-1061-23HLN+)
Gain, Return loss, Output power at 1dB compression (P1 dB), output IP3 (OIP3) and noise figure measured using Agilent's N5242A PNA-X microwave network analyzer.

- Conditions:
- Gain and Return loss: $P_{IN} = -25\text{dBm}$
 - Output IP3 (OIP3): Two tones, spaced 1 MHz apart, 0 dBm/ tone at output.

Components	Size	Value	Manu- facturer	P/N	
C1	0402	1.2pF	Murata	GRM1555C1H1R2WA01D	
C2,C3,C6		0.1uF		GRM155R71C104KA88D	
C4		0.001uF		GRM1555C1H102JA01D	
C5		0.01uF		GRM155R71E103KA01D	
R1		1.21KOhm		KOA	RK73H1ETTP1211F
L1		0805		0.68uH	Coilcraft
L2	0402	1nH	0402CS-1N0XJLW		

PRODUCT MARKING



Marking may contain other features or characters for internal lot control





Mini-Circuits

ULTRA HIGH DYNAMIC RANGE

Monolithic Amplifier

LHA-23HLN+

50Ω 30 MHz to 2 GHz

ADDITIONAL DETAILED TECHNICAL INFORMATION IS AVAILABLE ON OUR DASH BOARD [CLICK HERE](#)

Performance Data	Data Table Swept Graphs
Case Style	DQ1225 Plastic package, exposed paddle lead finish: Matte-Tin
Tape & Reel Standard quantities available on reel	F66 7" reels with 20, 50, 100, 200, 500, 1K, 2K or 3K devices
Suggested Layout for PCB Design	PL-587
Evaluation Board	TB-1061-23HLN+
Environmental Ratings	ENV08T9

NOTES

- A. Performance and quality attributes and conditions not expressly stated in this specification document are intended to be excluded and do not form a part of this specification document.
- B. Electrical specifications and performance data contained in this specification document are based on Mini-Circuit's applicable established test performance criteria and measurement instructions.
- C. The parts covered by this specification document are subject to Mini-Circuits standard limited warranty and terms and conditions (collectively, "Standard Terms"); Purchasers of this part are entitled to the rights and benefits contained therein. For a full statement of the standard terms and the exclusive rights and remedies thereunder, please visit Mini-Circuits' website at www.minicircuits.com/terms/viewterm.html



Typical Performance Data

NOTE: Use PDF Bookmarks to view DATA at required conditions

Definitions:

Input Return Loss = -S11 (dB)

Gain(Power Gain) = S21 (dB)

Reverse Isolation = -S12 (dB)

Output Return Loss = -S22 (dB)

TEST CONDITIONS: Vd = 8.00V, Id = 244.23mA @ Temperature = +25°C

FREQ	Gain	Isolation	Input Return Loss	Output Return Loss	Stability		IP-3 Output	1dB Comp. Output	Noise Figure
					K	Measure			
(MHz)	(dB)	(dB)	(dB)	(dB)	K	Measure	(dBm)	(dBm)	(dB)
20	23.60	26.61	10.53	14.56	1.02	0.48	42.76	25.93	1.27
30	23.23	26.14	11.48	14.33	1.02	0.46	44.86	25.98	1.22
40	22.99	25.92	11.87	13.74	1.03	0.45	43.99	28.03	1.14
50	22.84	25.80	12.11	13.38	1.03	0.44	44.84	27.46	1.13
60	22.74	25.73	12.27	13.14	1.03	0.44	45.75	27.50	1.07
70	22.68	25.69	12.36	13.00	1.03	0.44	44.78	27.07	1.10
80	22.64	25.66	12.44	12.93	1.04	0.43	44.58	28.21	1.04
90	22.61	25.64	12.48	12.86	1.04	0.43	44.56	27.70	1.05
100	22.58	25.63	12.50	12.80	1.04	0.43	45.36	27.48	1.06
150	22.50	25.62	12.47	12.74	1.04	0.44	45.75	27.77	1.00
200	22.45	25.64	12.41	12.74	1.04	0.45	45.21	27.84	1.01
250	22.40	25.68	12.29	12.75	1.05	0.46	44.75	28.02	1.01
300	22.36	25.73	12.09	12.79	1.05	0.47	45.49	27.99	1.10
350	22.31	25.79	11.97	12.86	1.05	0.48	46.40	28.10	1.05
400	22.26	25.86	11.76	12.91	1.06	0.50	45.39	28.02	1.07
450	22.21	25.93	11.57	13.01	1.06	0.52	45.59	28.17	1.11
500	22.16	26.01	11.38	13.09	1.07	0.53	44.91	28.21	1.08
550	22.10	26.09	11.24	13.26	1.07	0.55	45.14	27.90	1.07
600	22.05	26.18	11.04	13.35	1.08	0.57	45.94	28.04	1.32
650	21.99	26.29	10.91	13.48	1.08	0.59	45.95	28.01	1.09
700	21.93	26.40	10.69	13.58	1.09	0.61	45.74	27.98	1.03
750	21.86	26.52	10.60	13.68	1.10	0.63	46.00	28.19	1.28
800	21.79	26.65	10.45	13.76	1.11	0.65	46.13	28.07	1.17
850	21.73	26.77	10.35	13.88	1.12	0.67	45.07	27.91	1.13
900	21.67	26.89	10.20	13.90	1.13	0.68	45.51	27.89	1.19
950	21.61	27.03	10.10	13.93	1.14	0.70	45.53	28.37	1.17
1000	21.55	27.17	10.01	13.88	1.15	0.72	45.40	28.27	1.17
1100	21.42	27.47	9.84	13.72	1.17	0.75	45.49	27.92	1.22
1200	21.29	27.78	9.79	13.41	1.20	0.77	45.36	28.06	1.26
1300	21.16	28.11	9.82	13.00	1.23	0.79	45.51	28.01	1.31
1400	21.03	28.45	9.95	12.53	1.26	0.81	45.88	27.94	1.31
1500	20.90	28.80	10.18	12.04	1.30	0.82	44.72	28.02	1.36
1600	20.79	29.17	10.48	11.55	1.34	0.84	45.30	27.88	1.45
1700	20.67	29.53	10.86	11.09	1.39	0.84	45.34	27.92	1.44
1800	20.54	29.92	11.18	10.67	1.43	0.86	44.87	27.76	1.47
1900	20.39	30.33	11.40	10.27	1.48	0.87	45.12	27.74	1.53
2000	20.23	30.76	11.20	9.92	1.53	0.89	44.33	27.87	1.59
2100	20.00	31.26	10.63	9.58	1.58	0.91	44.19	27.62	1.68
2200	19.74	31.78	9.70	9.24	1.63	0.95	43.71	27.65	1.79
2300	19.38	32.36	8.57	8.92	1.69	0.98	43.86	27.37	2.01
2400	18.98	33.00	7.41	8.53	1.74	1.03	43.87	26.99	2.06
2500	18.49	33.72	6.30	8.15	1.80	1.07	43.44	27.05	2.37

Typical Performance Data

Definitions:

Input Return Loss = -S11 (dB)

Gain(Power Gain) = S21 (dB)

Reverse Isolation = -S12 (dB)

Output Return Loss = -S22 (dB)

TEST CONDITIONS: Vd = 7.60V, Id = 232.36mA @ Temperature = +25°C

FREQ	Gain	Isolation	Input Return Loss	Output Return Loss	Stability		IP-3 Output	1dB Comp. Output	Noise Figure
					K	Measure			
(MHz)	(dB)	(dB)	(dB)	(dB)	K	Measure	(dBm)	(dBm)	(dB)
20	23.60	26.59	10.51	14.53	1.02	0.48	43.15	25.52	1.19
30	23.24	26.12	11.46	14.30	1.02	0.46	44.18	25.64	1.16
40	22.99	25.90	11.89	13.70	1.03	0.45	45.22	27.59	1.09
50	22.84	25.78	12.14	13.34	1.03	0.44	44.31	27.12	1.05
60	22.75	25.71	12.30	13.11	1.03	0.43	45.65	27.14	1.02
70	22.68	25.67	12.39	12.97	1.03	0.43	45.26	26.75	1.01
80	22.64	25.64	12.50	12.90	1.04	0.43	44.79	27.76	0.98
90	22.61	25.62	12.53	12.83	1.04	0.43	45.61	27.32	1.02
100	22.59	25.61	12.54	12.77	1.04	0.43	45.95	27.13	1.00
150	22.51	25.60	12.52	12.71	1.04	0.44	46.40	27.38	1.00
200	22.46	25.62	12.46	12.71	1.04	0.44	45.74	27.44	0.94
250	22.41	25.66	12.34	12.74	1.05	0.45	45.85	27.63	0.97
300	22.36	25.71	12.15	12.79	1.05	0.47	45.37	27.59	1.00
350	22.32	25.77	12.01	12.86	1.05	0.48	47.69	27.70	1.03
400	22.27	25.84	11.81	12.92	1.06	0.50	46.36	27.61	1.06
450	22.21	25.91	11.61	13.03	1.06	0.51	46.26	27.78	1.02
500	22.16	25.98	11.41	13.12	1.07	0.53	45.15	27.82	1.06
550	22.10	26.07	11.28	13.30	1.07	0.55	46.17	27.47	1.02
600	22.05	26.16	11.08	13.41	1.08	0.57	46.67	27.63	1.25
650	21.99	26.26	10.95	13.56	1.08	0.59	47.04	27.58	1.06
700	21.93	26.37	10.72	13.67	1.09	0.61	47.21	27.55	1.04
750	21.86	26.50	10.63	13.79	1.10	0.63	46.68	27.76	1.24
800	21.79	26.62	10.48	13.88	1.11	0.65	47.21	27.62	1.14
850	21.74	26.74	10.37	14.02	1.12	0.66	46.43	27.45	1.11
900	21.68	26.87	10.22	14.06	1.13	0.68	47.42	27.42	1.17
950	21.62	27.00	10.13	14.10	1.14	0.70	47.19	27.93	1.12
1000	21.55	27.14	10.02	14.06	1.15	0.72	46.75	27.84	1.12
1100	21.43	27.44	9.85	13.92	1.17	0.75	47.87	27.45	1.19
1200	21.29	27.75	9.80	13.60	1.20	0.77	47.24	27.61	1.25
1300	21.16	28.08	9.82	13.20	1.23	0.80	47.88	27.55	1.25
1400	21.04	28.41	9.95	12.71	1.26	0.81	47.57	27.49	1.27
1500	20.90	28.76	10.17	12.21	1.30	0.83	47.71	27.60	1.32
1600	20.79	29.11	10.47	11.70	1.34	0.84	47.93	27.45	1.42
1700	20.68	29.47	10.86	11.24	1.38	0.85	47.55	27.51	1.42
1800	20.55	29.85	11.19	10.81	1.42	0.86	46.90	27.32	1.42
1900	20.40	30.26	11.41	10.40	1.47	0.87	47.21	27.33	1.48
2000	20.23	30.67	11.22	10.04	1.52	0.89	46.15	27.47	1.57
2100	20.01	31.16	10.66	9.69	1.57	0.92	47.15	27.20	1.64
2200	19.75	31.65	9.73	9.36	1.62	0.95	45.62	27.27	1.74
2300	19.39	32.23	8.61	9.04	1.67	0.99	47.54	26.93	1.95
2400	18.98	32.86	7.43	8.65	1.72	1.03	47.53	26.52	2.02
2500	18.50	33.57	6.31	8.27	1.78	1.08	47.44	26.58	2.29

Typical Performance Data

Definitions:

Input Return Loss = -S11 (dB)

Gain(Power Gain) = S21 (dB)

Reverse Isolation = -S12 (dB)

Output Return Loss = -S22 (dB)

TEST CONDITIONS: Vd = 8.40V, Id = 255.31mA @ Temperature = +25°C

FREQ	Gain	Isolation	Input Return Loss	Output Return Loss	Stability		IP-3 Output	1dB Comp. Output	Noise Figure
					K	Measure			
(MHz)	(dB)	(dB)	(dB)	(dB)	K	Measure	(dBm)	(dBm)	(dB)
20	23.58	26.63	10.56	14.60	1.02	0.49	42.18	26.32	1.30
30	23.22	26.16	11.45	14.39	1.02	0.47	43.04	26.30	1.28
40	22.97	25.94	11.84	13.79	1.03	0.46	43.39	28.44	1.19
50	22.83	25.81	12.08	13.43	1.03	0.45	44.49	27.78	1.19
60	22.73	25.74	12.21	13.20	1.03	0.44	43.93	27.85	1.10
70	22.67	25.71	12.32	13.05	1.04	0.44	43.65	27.39	1.12
80	22.63	25.67	12.39	12.98	1.04	0.44	44.38	28.64	1.08
90	22.60	25.66	12.42	12.91	1.04	0.44	45.69	28.05	1.13
100	22.57	25.65	12.43	12.85	1.04	0.44	44.59	27.83	1.12
150	22.49	25.64	12.42	12.78	1.04	0.44	46.48	28.14	1.07
200	22.44	25.66	12.35	12.77	1.05	0.45	44.66	28.22	1.05
250	22.40	25.70	12.23	12.78	1.05	0.46	44.38	28.40	1.05
300	22.35	25.74	12.04	12.82	1.05	0.47	45.40	28.37	1.10
350	22.30	25.81	11.90	12.88	1.05	0.49	46.85	28.47	1.09
400	22.25	25.87	11.72	12.92	1.06	0.50	45.88	28.40	1.15
450	22.20	25.95	11.53	13.00	1.06	0.52	45.02	28.54	1.12
500	22.15	26.03	11.34	13.07	1.07	0.53	44.70	28.59	1.14
550	22.09	26.12	11.20	13.22	1.07	0.55	45.08	28.31	1.12
600	22.04	26.21	11.01	13.30	1.08	0.57	44.50	28.44	1.32
650	21.98	26.31	10.88	13.41	1.09	0.59	44.46	28.42	1.13
700	21.92	26.42	10.67	13.49	1.09	0.61	44.48	28.40	1.17
750	21.85	26.54	10.57	13.57	1.10	0.63	44.56	28.59	1.34
800	21.78	26.66	10.43	13.63	1.11	0.65	44.33	28.49	1.20
850	21.72	26.79	10.33	13.73	1.12	0.67	44.20	28.36	1.19
900	21.66	26.91	10.19	13.74	1.13	0.68	44.26	28.33	1.23
950	21.60	27.05	10.10	13.75	1.14	0.70	44.24	28.78	1.23
1000	21.54	27.19	10.00	13.69	1.15	0.71	44.31	28.67	1.24
1100	21.41	27.49	9.84	13.51	1.17	0.74	44.47	28.36	1.28
1200	21.28	27.81	9.80	13.20	1.20	0.77	44.75	28.48	1.32
1300	21.15	28.14	9.83	12.80	1.23	0.79	44.22	28.44	1.37
1400	21.03	28.48	9.96	12.34	1.27	0.81	44.04	28.35	1.36
1500	20.90	28.84	10.19	11.87	1.31	0.82	44.12	28.41	1.41
1600	20.78	29.21	10.49	11.39	1.35	0.83	44.38	28.29	1.50
1700	20.67	29.59	10.87	10.94	1.39	0.84	43.88	28.28	1.49
1800	20.54	29.98	11.19	10.53	1.44	0.85	43.75	28.16	1.50
1900	20.39	30.41	11.39	10.14	1.49	0.87	43.92	28.12	1.57
2000	20.22	30.85	11.18	9.80	1.54	0.89	43.19	28.23	1.67
2100	20.00	31.36	10.61	9.45	1.59	0.91	43.09	28.00	1.76
2200	19.73	31.88	9.67	9.11	1.64	0.94	42.90	28.02	1.87
2300	19.37	32.49	8.56	8.79	1.71	0.98	42.81	27.76	2.08
2400	18.97	33.15	7.39	8.40	1.76	1.02	42.65	27.40	2.21
2500	18.48	33.88	6.28	8.02	1.82	1.07	42.31	27.47	2.44

Typical Performance Data

Definitions:

Input Return Loss = -S11 (dB)

Gain(Power Gain) = S21 (dB)

Reverse Isolation = -S12 (dB)

Output Return Loss = -S22 (dB)

TEST CONDITIONS: Vd = 8.00V, Id = 255.12mA @ Temperature = -45°C

FREQ	Gain	Isolation	Input Return Loss	Output Return Loss	Stability		IP-3 Output	1dB Comp. Output	Noise Figure
					K	Measure			
(MHz)	(dB)	(dB)	(dB)	(dB)	K	Measure	(dBm)	(dBm)	(dB)
20	23.66	26.52	10.41	14.59	1.02	0.47	46.55	26.27	1.29
30	23.30	26.05	11.45	14.42	1.02	0.45	46.62	26.19	1.08
40	23.05	25.83	11.95	13.85	1.02	0.43	47.88	28.56	0.94
50	22.91	25.71	12.26	13.53	1.03	0.43	48.47	28.10	0.84
60	22.82	25.64	12.49	13.34	1.03	0.42	49.46	27.90	0.77
70	22.76	25.59	12.66	13.24	1.03	0.42	49.37	27.38	0.75
80	22.72	25.56	12.78	13.21	1.03	0.42	52.78	28.83	0.70
90	22.69	25.54	12.90	13.20	1.03	0.42	50.86	28.23	0.74
100	22.67	25.53	12.97	13.19	1.03	0.42	50.93	27.77	0.72
150	22.61	25.49	13.20	13.32	1.04	0.42	50.66	28.20	0.65
200	22.56	25.51	13.14	13.28	1.04	0.43	49.92	28.28	0.68
250	22.51	25.56	12.87	13.06	1.04	0.43	48.16	28.50	0.69
300	22.46	25.61	12.43	12.81	1.04	0.44	48.62	28.40	0.71
350	22.40	25.68	12.15	12.66	1.05	0.46	48.75	28.49	0.73
400	22.36	25.75	11.90	12.64	1.05	0.47	48.19	28.35	0.78
450	22.31	25.81	11.73	12.76	1.05	0.49	47.33	28.58	0.78
500	22.27	25.88	11.62	12.94	1.06	0.50	46.29	28.65	0.76
550	22.22	25.95	11.55	13.20	1.06	0.52	45.25	28.15	0.71
600	22.19	26.03	11.42	13.41	1.07	0.54	44.61	28.37	0.83
650	22.14	26.11	11.34	13.60	1.07	0.55	44.26	28.34	0.75
700	22.09	26.21	11.16	13.78	1.08	0.57	43.57	28.30	0.76
750	22.04	26.32	11.11	13.93	1.09	0.59	43.73	28.58	0.85
800	21.98	26.43	11.03	14.01	1.09	0.61	43.58	28.37	0.81
850	21.92	26.54	10.97	14.12	1.10	0.63	42.78	28.18	0.77
900	21.88	26.66	10.82	14.09	1.11	0.64	42.78	28.17	0.83
950	21.83	26.78	10.69	14.06	1.12	0.66	42.47	28.80	0.82
1000	21.77	26.90	10.57	13.98	1.13	0.67	42.52	28.78	0.82
1100	21.66	27.18	10.38	13.91	1.15	0.70	42.14	28.30	0.87
1200	21.55	27.47	10.36	13.75	1.17	0.73	41.92	28.53	0.89
1300	21.44	27.77	10.35	13.49	1.19	0.76	41.70	28.40	0.95
1400	21.33	28.08	10.46	13.14	1.22	0.78	41.64	28.40	0.92
1500	21.21	28.41	10.74	12.66	1.26	0.79	41.13	28.63	0.99
1600	21.11	28.75	11.07	12.13	1.29	0.81	40.99	28.41	1.05
1700	21.01	29.08	11.47	11.66	1.33	0.82	40.96	28.60	1.06
1800	20.91	29.43	11.92	11.26	1.36	0.83	40.56	28.25	1.05
1900	20.78	29.83	12.29	10.86	1.41	0.84	40.78	28.30	1.13
2000	20.64	30.24	12.12	10.56	1.45	0.87	40.50	28.55	1.18
2100	20.46	30.67	11.51	10.30	1.49	0.89	40.11	28.27	1.23
2200	20.24	31.19	10.59	9.96	1.54	0.93	39.92	28.55	1.30
2300	19.93	31.74	9.37	9.60	1.58	0.97	39.74	28.12	1.45
2400	19.56	32.37	8.10	9.17	1.63	1.01	39.39	27.72	1.53
2500	19.12	33.09	6.88	8.69	1.68	1.06	39.16	27.79	1.72

Typical Performance Data

Definitions:

Input Return Loss = -S11 (dB)

Gain(Power Gain) = S21 (dB)

Reverse Isolation = -S12 (dB)

Output Return Loss = -S22 (dB)

TEST CONDITIONS: Vd = 7.60V, Id = 240.54mA @ Temperature = -45°C

FREQ	Gain	Isolation	Input Return Loss	Output Return Loss	Stability		IP-3 Output	1dB Comp. Output	Noise Figure
					K	Measure			
(MHz)	(dB)	(dB)	(dB)	(dB)	K	Measure	(dBm)	(dBm)	(dB)
20	23.65	26.50	10.39	14.65	1.02	0.47	45.49	25.81	1.17
30	23.28	26.03	11.48	14.49	1.02	0.45	47.04	25.85	0.99
40	23.03	25.80	11.99	13.92	1.02	0.43	49.03	28.08	0.85
50	22.89	25.68	12.33	13.60	1.03	0.43	49.58	27.72	0.81
60	22.80	25.61	12.56	13.41	1.03	0.42	49.92	27.51	0.73
70	22.74	25.56	12.72	13.31	1.03	0.42	50.85	27.04	0.72
80	22.70	25.53	12.87	13.29	1.03	0.42	48.63	28.26	0.67
90	22.67	25.51	12.98	13.27	1.03	0.42	50.67	27.80	0.69
100	22.65	25.50	13.05	13.26	1.03	0.42	48.79	27.41	0.70
150	22.59	25.47	13.26	13.39	1.04	0.42	50.60	27.79	0.66
200	22.55	25.49	13.21	13.34	1.04	0.43	48.38	27.87	0.65
250	22.50	25.53	12.92	13.11	1.04	0.43	49.42	28.08	0.66
300	22.44	25.59	12.51	12.87	1.04	0.44	48.49	27.97	0.70
350	22.39	25.65	12.20	12.72	1.05	0.46	49.84	28.07	0.69
400	22.34	25.72	11.95	12.70	1.05	0.47	47.84	27.92	0.73
450	22.29	25.78	11.78	12.83	1.05	0.49	47.10	28.16	0.74
500	22.26	25.85	11.67	13.00	1.06	0.50	45.99	28.21	0.73
550	22.21	25.93	11.59	13.26	1.06	0.52	45.34	27.71	0.69
600	22.17	26.00	11.45	13.46	1.07	0.54	44.80	27.92	0.86
650	22.13	26.09	11.37	13.67	1.07	0.55	44.88	27.87	0.74
700	22.08	26.18	11.19	13.85	1.08	0.57	43.90	27.86	0.74
750	22.02	26.29	11.13	13.99	1.09	0.59	43.92	28.12	0.90
800	21.96	26.41	11.05	14.07	1.09	0.61	43.66	27.91	0.81
850	21.91	26.52	10.98	14.17	1.10	0.63	42.82	27.72	0.79
900	21.86	26.63	10.83	14.13	1.11	0.64	42.67	27.70	0.81
950	21.81	26.75	10.69	14.11	1.12	0.66	43.22	28.33	0.78
1000	21.76	26.88	10.57	14.04	1.13	0.67	42.86	28.30	0.77
1100	21.65	27.16	10.37	13.95	1.14	0.71	42.11	27.80	0.85
1200	21.54	27.44	10.35	13.77	1.17	0.73	42.10	28.04	0.87
1300	21.42	27.75	10.33	13.52	1.19	0.76	41.80	27.91	0.91
1400	21.32	28.06	10.44	13.17	1.22	0.78	41.71	27.89	0.92
1500	21.20	28.39	10.71	12.67	1.26	0.79	41.33	28.14	0.96
1600	21.10	28.72	11.03	12.14	1.29	0.81	41.11	27.91	1.03
1700	21.00	29.05	11.44	11.68	1.32	0.82	41.08	28.12	1.04
1800	20.90	29.40	11.90	11.26	1.36	0.83	40.66	27.76	1.02
1900	20.77	29.80	12.27	10.86	1.40	0.84	40.68	27.82	1.08
2000	20.63	30.21	12.10	10.57	1.45	0.86	40.58	28.08	1.13
2100	20.45	30.64	11.50	10.31	1.49	0.89	40.46	27.78	1.21
2200	20.23	31.15	10.61	9.96	1.53	0.93	40.19	28.07	1.26
2300	19.93	31.69	9.38	9.60	1.58	0.97	39.89	27.62	1.43
2400	19.55	32.33	8.11	9.19	1.63	1.01	39.48	27.17	1.48
2500	19.12	33.05	6.89	8.70	1.67	1.06	39.32	27.23	1.70

Typical Performance Data

Definitions:

Input Return Loss = -S11 (dB)

Gain(Power Gain) = S21 (dB)

Reverse Isolation = -S12 (dB)

Output Return Loss = -S22 (dB)

TEST CONDITIONS: Vd = 8.40V, Id = 269.36mA @ Temperature = -45°C

FREQ	Gain	Isolation	Input Return Loss	Output Return Loss	Stability		IP-3 Output	1dB Comp. Output	Noise Figure
					K	Measure			
(MHz)	(dB)	(dB)	(dB)	(dB)	K	Measure	(dBm)	(dBm)	(dB)
20	23.68	26.54	10.37	14.56	1.02	0.47	44.33	26.67	1.38
30	23.32	26.07	11.42	14.37	1.02	0.45	47.54	26.49	1.16
40	23.07	25.85	11.92	13.80	1.02	0.43	50.52	28.99	0.97
50	22.93	25.73	12.21	13.49	1.03	0.43	48.54	28.44	0.89
60	22.83	25.66	12.42	13.30	1.03	0.42	50.49	28.25	0.80
70	22.78	25.61	12.58	13.20	1.03	0.42	49.45	27.63	0.79
80	22.74	25.58	12.74	13.17	1.03	0.42	50.09	29.28	0.74
90	22.71	25.56	12.83	13.16	1.03	0.42	51.63	28.61	0.77
100	22.69	25.55	12.91	13.14	1.03	0.42	48.40	28.12	0.77
150	22.63	25.52	13.12	13.27	1.04	0.42	51.65	28.58	0.69
200	22.58	25.54	13.07	13.21	1.04	0.43	48.93	28.67	0.69
250	22.53	25.58	12.79	12.98	1.04	0.43	49.48	28.88	0.72
300	22.47	25.64	12.37	12.74	1.04	0.44	48.94	28.78	0.71
350	22.42	25.70	12.09	12.60	1.05	0.45	49.02	28.88	0.76
400	22.37	25.77	11.85	12.58	1.05	0.47	47.92	28.75	0.78
450	22.33	25.83	11.69	12.70	1.05	0.48	46.40	28.98	0.76
500	22.29	25.90	11.59	12.87	1.06	0.50	46.27	29.05	0.77
550	22.24	25.97	11.51	13.11	1.06	0.52	45.14	28.56	0.76
600	22.21	26.05	11.39	13.31	1.07	0.54	44.37	28.77	0.89
650	22.16	26.14	11.32	13.50	1.07	0.55	44.10	28.74	0.79
700	22.11	26.23	11.15	13.68	1.08	0.57	43.53	28.72	0.80
750	22.06	26.34	11.10	13.82	1.09	0.59	43.75	29.00	0.94
800	22.00	26.45	11.02	13.89	1.09	0.61	43.29	28.79	0.86
850	21.94	26.56	10.96	13.98	1.10	0.63	42.69	28.61	0.81
900	21.90	26.67	10.83	13.95	1.11	0.64	42.53	28.59	0.89
950	21.85	26.80	10.70	13.92	1.12	0.66	42.60	29.23	0.84
1000	21.80	26.92	10.58	13.86	1.13	0.67	42.40	29.21	0.82
1100	21.69	27.20	10.41	13.78	1.15	0.70	42.05	28.75	0.88
1200	21.58	27.48	10.38	13.60	1.17	0.73	41.88	28.99	0.91
1300	21.46	27.79	10.37	13.37	1.19	0.75	41.53	28.86	0.95
1400	21.36	28.10	10.50	13.04	1.22	0.77	41.41	28.83	0.98
1500	21.24	28.43	10.78	12.57	1.26	0.79	40.96	29.06	1.02
1600	21.14	28.77	11.11	12.05	1.29	0.80	40.80	28.85	1.07
1700	21.04	29.11	11.51	11.61	1.33	0.81	40.74	29.01	1.05
1800	20.93	29.46	11.97	11.20	1.36	0.83	40.44	28.69	1.10
1900	20.80	29.86	12.32	10.80	1.41	0.84	40.34	28.73	1.15
2000	20.66	30.28	12.14	10.51	1.45	0.86	40.23	28.96	1.19
2100	20.48	30.72	11.53	10.25	1.49	0.89	40.11	28.69	1.26
2200	20.27	31.24	10.61	9.90	1.54	0.93	39.74	28.94	1.34
2300	19.96	31.80	9.38	9.54	1.59	0.97	39.57	28.55	1.50
2400	19.59	32.43	8.10	9.13	1.63	1.01	39.20	28.18	1.59
2500	19.15	33.16	6.89	8.63	1.68	1.06	38.93	28.25	1.78

Typical Performance Data

Definitions:

Input Return Loss = -S11 (dB)

Gain(Power Gain) = S21 (dB)

Reverse Isolation = -S12 (dB)

Output Return Loss = -S22 (dB)

TEST CONDITIONS: Vd = 8.00V, Id = 221.97mA @ Temperature = +95°C

FREQ	Gain	Isolation	Input Return Loss	Output Return Loss	Stability		IP-3 Output	1dB Comp. Output	Noise Figure
					K	Measure			
(MHz)	(dB)	(dB)	(dB)	(dB)	K	Measure	(dBm)	(dBm)	(dB)
20	23.04	26.75	10.98	14.59	1.05	0.56	36.72	25.05	1.74
30	22.72	26.26	11.92	14.61	1.05	0.54	37.88	25.41	1.68
40	22.50	26.03	12.30	14.06	1.05	0.52	38.56	26.92	1.57
50	22.36	25.91	12.50	13.68	1.05	0.51	38.63	26.34	1.56
60	22.27	25.84	12.61	13.40	1.06	0.51	39.31	26.61	1.53
70	22.21	25.80	12.64	13.20	1.06	0.51	39.31	26.39	1.54
80	22.17	25.77	12.65	13.06	1.06	0.50	39.59	27.05	1.49
90	22.14	25.76	12.63	12.94	1.06	0.50	39.75	26.72	1.55
100	22.11	25.76	12.58	12.83	1.06	0.50	39.81	26.73	1.57
150	22.02	25.76	12.30	12.57	1.06	0.51	40.38	26.91	1.55
200	21.95	25.80	12.05	12.48	1.07	0.52	40.50	26.97	1.53
250	21.90	25.84	11.92	12.60	1.07	0.53	40.15	27.07	1.56
300	21.86	25.88	11.77	12.84	1.07	0.54	40.56	27.10	1.59
350	21.82	25.94	11.68	13.13	1.08	0.56	40.90	27.19	1.61
400	21.77	26.01	11.53	13.40	1.08	0.58	40.49	27.16	1.64
450	21.71	26.09	11.33	13.63	1.09	0.60	40.44	27.20	1.62
500	21.66	26.18	11.11	13.81	1.10	0.61	40.20	27.21	1.62
550	21.59	26.27	10.89	13.99	1.10	0.63	40.80	27.11	1.60
600	21.53	26.38	10.63	14.10	1.11	0.65	40.62	27.18	1.65
650	21.45	26.50	10.44	14.21	1.12	0.67	40.83	27.15	1.61
700	21.38	26.62	10.18	14.32	1.13	0.69	40.86	27.13	1.63
750	21.30	26.76	10.03	14.41	1.14	0.71	41.17	27.25	1.76
800	21.23	26.89	9.87	14.49	1.15	0.73	41.39	27.26	1.70
850	21.17	27.02	9.74	14.58	1.16	0.75	41.34	27.20	1.65
900	21.11	27.16	9.58	14.56	1.17	0.76	41.65	27.18	1.72
950	21.04	27.30	9.47	14.53	1.18	0.78	41.38	27.38	1.71
1000	20.98	27.45	9.38	14.42	1.20	0.79	41.18	27.18	1.70
1100	20.85	27.76	9.24	14.10	1.23	0.82	42.32	27.07	1.77
1200	20.74	28.08	9.21	13.64	1.26	0.83	42.44	27.07	1.78
1300	20.63	28.39	9.25	13.12	1.29	0.85	43.38	27.14	1.84
1400	20.53	28.72	9.39	12.58	1.32	0.86	43.29	27.00	1.84
1500	20.43	29.05	9.61	12.04	1.36	0.87	42.82	26.96	1.89
1600	20.34	29.39	9.90	11.51	1.40	0.87	43.31	26.92	1.94
1700	20.24	29.74	10.21	11.00	1.44	0.88	42.46	26.77	1.96
1800	20.12	30.10	10.45	10.56	1.48	0.89	43.64	26.83	2.00
1900	19.97	30.54	10.57	10.10	1.53	0.90	43.59	26.74	2.09
2000	19.79	30.99	10.33	9.69	1.58	0.91	42.92	26.73	2.19
2100	19.55	31.47	9.76	9.30	1.63	0.94	43.06	26.54	2.28
2200	19.27	32.03	8.91	8.89	1.69	0.97	42.80	26.35	2.41
2300	18.88	32.62	7.91	8.52	1.75	1.00	43.09	26.17	2.61
2400	18.44	33.26	6.87	8.14	1.80	1.04	43.48	25.80	2.82
2500	17.92	33.97	5.88	7.74	1.86	1.08	44.07	25.85	3.07

Typical Performance Data

Definitions:

Input Return Loss = -S11 (dB)

Gain(Power Gain) = S21 (dB)

Reverse Isolation = -S12 (dB)

Output Return Loss = -S22 (dB)

TEST CONDITIONS: Vd = 7.60V, Id = 212.07mA @ Temperature = +95°C

FREQ	Gain	Isolation	Input Return Loss	Output Return Loss	Stability		IP-3 Output	1dB Comp. Output	Noise Figure
					K	Measure			
(MHz)	(dB)	(dB)	(dB)	(dB)	K	Measure	(dBm)	(dBm)	(dB)
20	23.10	26.71	10.90	14.56	1.05	0.55	36.98	24.74	1.67
30	22.77	26.23	11.86	14.52	1.04	0.53	38.32	25.13	1.61
40	22.55	26.00	12.31	13.96	1.05	0.51	39.01	26.58	1.50
50	22.41	25.87	12.53	13.58	1.05	0.50	39.25	26.11	1.49
60	22.32	25.80	12.64	13.30	1.05	0.50	39.55	26.33	1.49
70	22.26	25.76	12.67	13.10	1.05	0.50	39.70	26.16	1.46
80	22.22	25.74	12.69	12.97	1.05	0.49	39.99	26.58	1.45
90	22.18	25.73	12.67	12.85	1.06	0.49	39.97	26.44	1.50
100	22.15	25.72	12.61	12.73	1.06	0.49	40.15	26.42	1.50
150	22.06	25.73	12.35	12.47	1.06	0.50	40.72	26.61	1.45
200	22.00	25.76	12.10	12.40	1.06	0.51	40.80	26.66	1.46
250	21.95	25.80	11.99	12.54	1.07	0.52	40.72	26.78	1.53
300	21.90	25.85	11.85	12.80	1.07	0.53	41.01	26.81	1.58
350	21.86	25.90	11.76	13.10	1.08	0.55	41.46	26.89	1.54
400	21.82	25.97	11.62	13.37	1.08	0.57	41.06	26.85	1.58
450	21.76	26.05	11.39	13.59	1.09	0.59	40.87	26.91	1.54
500	21.70	26.14	11.16	13.77	1.09	0.61	40.47	26.92	1.56
550	21.63	26.24	10.94	13.95	1.10	0.62	41.10	26.79	1.54
600	21.57	26.34	10.68	14.08	1.11	0.64	40.95	26.86	1.62
650	21.50	26.46	10.49	14.23	1.12	0.66	41.26	26.82	1.56
700	21.43	26.58	10.23	14.37	1.12	0.68	41.73	26.80	1.61
750	21.35	26.72	10.08	14.48	1.14	0.70	41.70	26.93	1.75
800	21.28	26.85	9.92	14.58	1.15	0.72	42.09	26.92	1.66
850	21.22	26.97	9.78	14.69	1.16	0.74	42.35	26.84	1.60
900	21.15	27.12	9.62	14.68	1.17	0.76	42.75	26.81	1.65
950	21.09	27.26	9.50	14.66	1.18	0.77	42.38	27.06	1.66
1000	21.02	27.41	9.40	14.56	1.19	0.79	41.86	26.85	1.65
1100	20.89	27.72	9.24	14.27	1.22	0.81	43.37	26.69	1.72
1200	20.77	28.03	9.21	13.81	1.25	0.83	43.44	26.72	1.72
1300	20.66	28.35	9.24	13.30	1.28	0.85	44.63	26.76	1.79
1400	20.56	28.67	9.37	12.76	1.32	0.86	44.19	26.64	1.77
1500	20.45	29.00	9.59	12.22	1.35	0.87	43.82	26.61	1.83
1600	20.36	29.34	9.88	11.68	1.39	0.87	44.22	26.57	1.89
1700	20.26	29.67	10.19	11.17	1.43	0.88	43.28	26.44	1.92
1800	20.14	30.03	10.43	10.73	1.47	0.89	44.52	26.49	1.93
1900	20.00	30.45	10.56	10.27	1.52	0.90	44.23	26.41	2.04
2000	19.82	30.89	10.33	9.85	1.57	0.92	44.27	26.42	2.13
2100	19.58	31.36	9.77	9.46	1.62	0.94	44.14	26.20	2.24
2200	19.30	31.89	8.93	9.04	1.67	0.97	43.66	26.04	2.34
2300	18.91	32.47	7.92	8.68	1.72	1.01	43.97	25.83	2.58
2400	18.47	33.10	6.89	8.29	1.78	1.04	44.44	25.44	2.78
2500	17.95	33.79	5.89	7.89	1.83	1.08	45.44	25.50	2.98

Typical Performance Data

Definitions:

Input Return Loss = -S11 (dB)

Gain(Power Gain) = S21 (dB)

Reverse Isolation = -S12 (dB)

Output Return Loss = -S22 (dB)

TEST CONDITIONS: Vd = 8.40V, Id = 226.90mA @ Temperature = +95°C

FREQ	Gain	Isolation	Input Return Loss	Output Return Loss	Stability		IP-3 Output	1dB Comp. Output	Noise Figure
					K	Measure			
(MHz)	(dB)	(dB)	(dB)	(dB)	K	Measure	(dBm)	(dBm)	(dB)
20	22.99	26.78	11.04	14.70	1.06	0.56	36.01	25.37	1.88
30	22.68	26.29	11.92	14.74	1.05	0.54	37.12	25.72	1.80
40	22.46	26.06	12.28	14.18	1.05	0.53	37.86	27.27	1.69
50	22.33	25.94	12.45	13.79	1.06	0.52	38.27	26.58	1.69
60	22.24	25.87	12.54	13.51	1.06	0.52	38.68	26.93	1.65
70	22.18	25.83	12.56	13.30	1.06	0.51	38.94	26.65	1.64
80	22.14	25.81	12.57	13.16	1.06	0.51	39.01	27.39	1.63
90	22.10	25.79	12.54	13.04	1.06	0.51	39.32	27.04	1.68
100	22.07	25.79	12.49	12.93	1.06	0.51	39.25	27.07	1.68
150	21.98	25.80	12.20	12.65	1.07	0.52	39.94	27.23	1.66
200	21.92	25.83	11.97	12.57	1.07	0.53	39.89	27.30	1.65
250	21.87	25.87	11.83	12.69	1.07	0.54	39.88	27.40	1.66
300	21.83	25.92	11.70	12.94	1.08	0.55	40.17	27.44	1.69
350	21.79	25.97	11.62	13.23	1.08	0.57	40.61	27.53	1.70
400	21.74	26.04	11.49	13.47	1.09	0.58	40.22	27.50	1.75
450	21.68	26.12	11.26	13.66	1.09	0.60	40.02	27.52	1.74
500	21.63	26.21	11.04	13.80	1.10	0.62	39.86	27.52	1.72
550	21.56	26.31	10.82	13.94	1.11	0.64	39.97	27.47	1.72
600	21.50	26.41	10.57	14.03	1.11	0.66	39.99	27.51	1.78
650	21.42	26.53	10.38	14.13	1.12	0.68	40.37	27.49	1.73
700	21.35	26.65	10.13	14.22	1.13	0.69	40.50	27.47	1.77
750	21.28	26.79	10.00	14.29	1.14	0.71	40.57	27.57	1.85
800	21.21	26.92	9.84	14.35	1.15	0.73	40.70	27.60	1.80
850	21.15	27.05	9.71	14.40	1.16	0.75	40.85	27.56	1.79
900	21.08	27.19	9.56	14.34	1.18	0.76	40.98	27.55	1.81
950	21.02	27.33	9.46	14.29	1.19	0.78	40.80	27.69	1.81
1000	20.95	27.48	9.37	14.16	1.20	0.79	40.66	27.47	1.80
1100	20.83	27.79	9.22	13.82	1.23	0.81	41.36	27.41	1.85
1200	20.71	28.11	9.21	13.36	1.26	0.83	41.66	27.39	1.85
1300	20.60	28.43	9.25	12.84	1.29	0.85	42.22	27.49	1.93
1400	20.51	28.77	9.39	12.32	1.33	0.86	42.30	27.34	1.93
1500	20.40	29.11	9.61	11.80	1.37	0.86	41.86	27.27	1.98
1600	20.31	29.46	9.90	11.29	1.41	0.87	42.19	27.25	2.03
1700	20.21	29.82	10.21	10.79	1.45	0.87	41.60	27.06	2.04
1800	20.09	30.19	10.44	10.37	1.49	0.88	42.44	27.17	2.10
1900	19.94	30.65	10.55	9.92	1.55	0.89	42.22	27.08	2.18
2000	19.76	31.11	10.29	9.52	1.60	0.91	42.09	27.04	2.27
2100	19.52	31.62	9.71	9.14	1.65	0.93	41.65	26.87	2.39
2200	19.23	32.19	8.87	8.72	1.71	0.96	41.62	26.64	2.52
2300	18.85	32.79	7.86	8.36	1.77	1.00	42.01	26.49	2.75
2400	18.41	33.46	6.83	7.98	1.83	1.03	42.10	26.15	2.95
2500	17.89	34.18	5.85	7.57	1.88	1.07	42.65	26.19	3.22

Typical Performance Curves

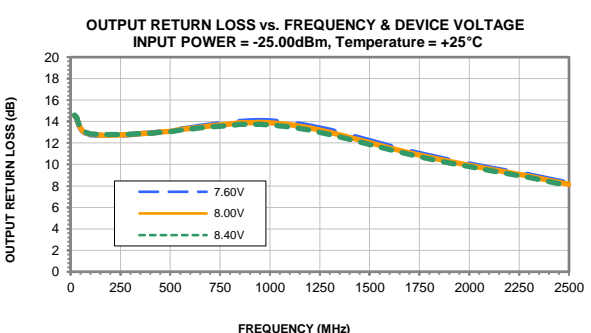
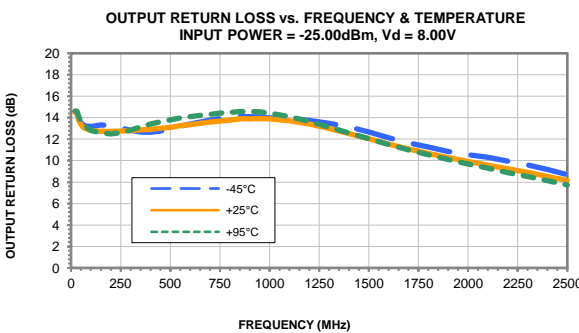
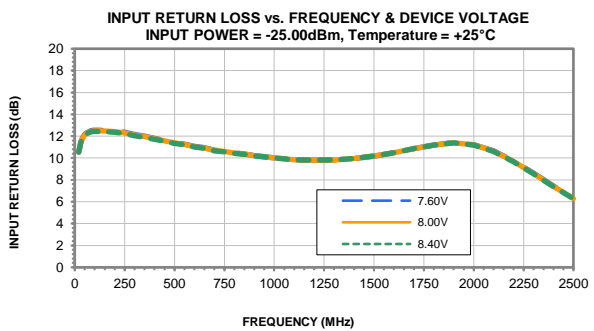
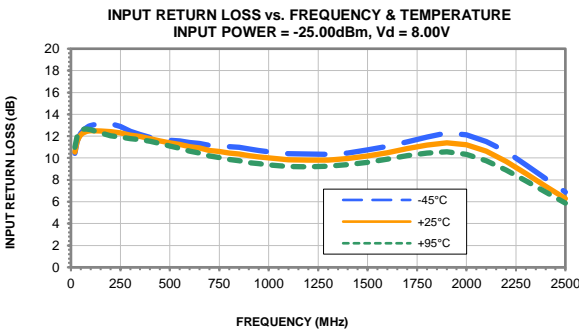
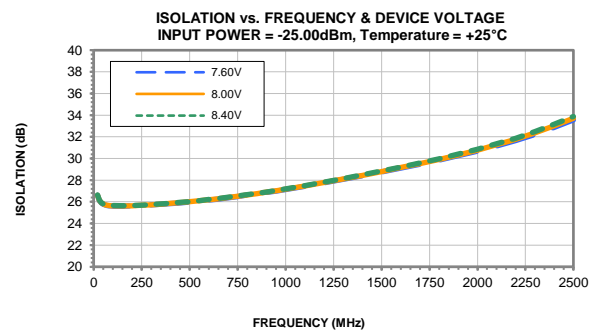
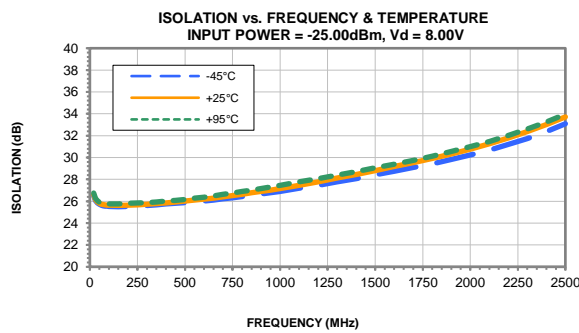
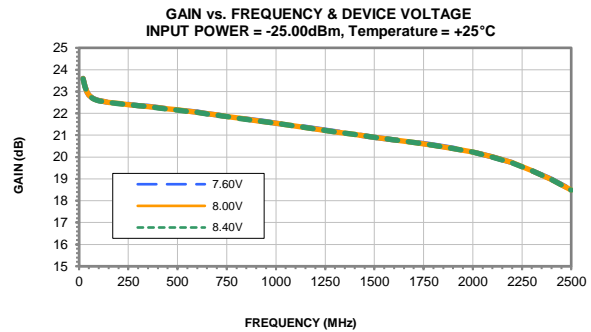
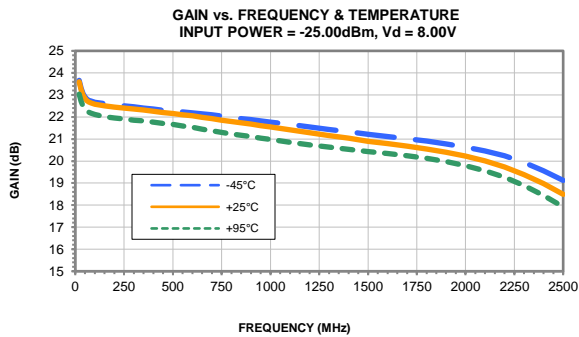

Typical Performance Curves

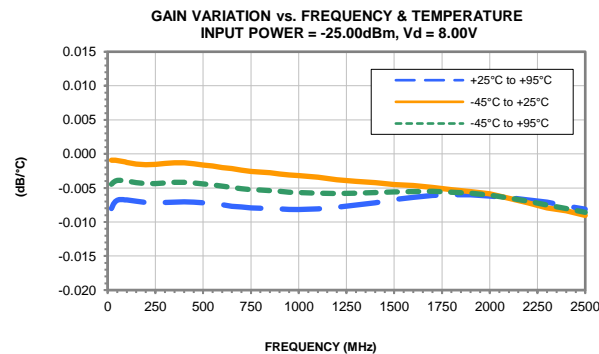
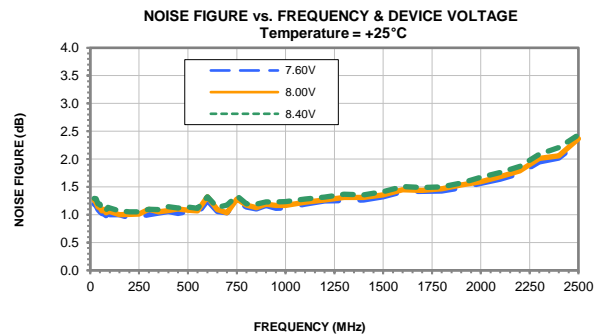
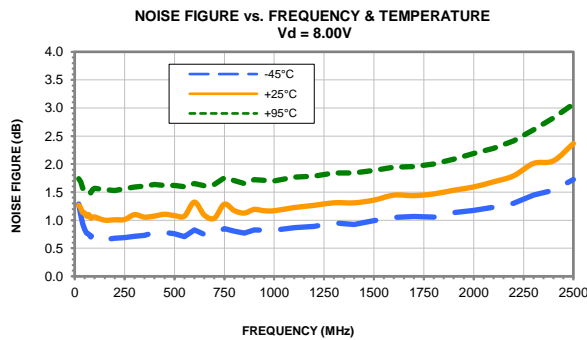
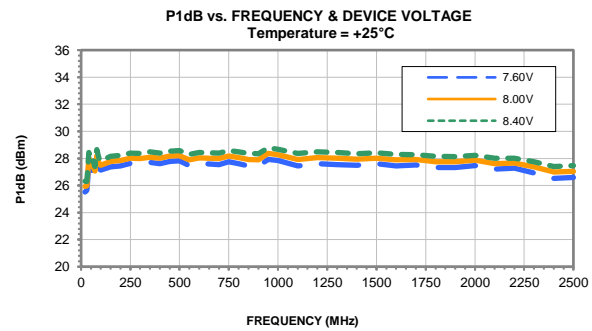
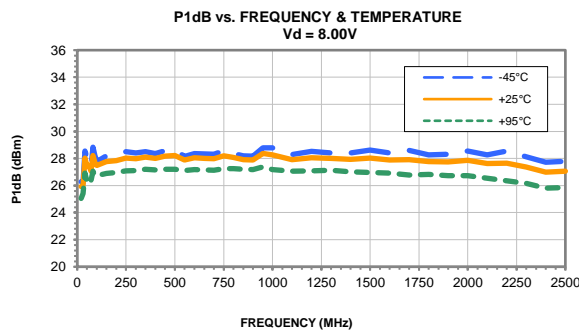
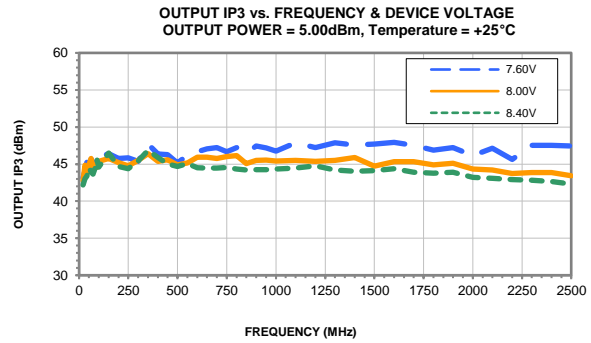
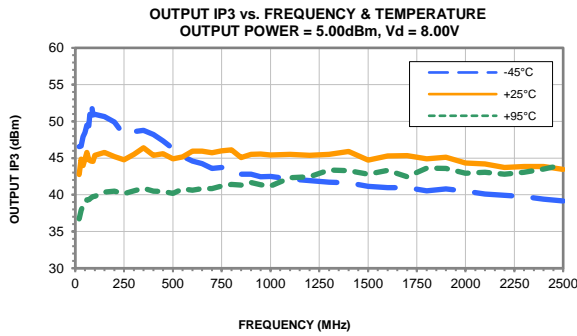

Outline Dimensions

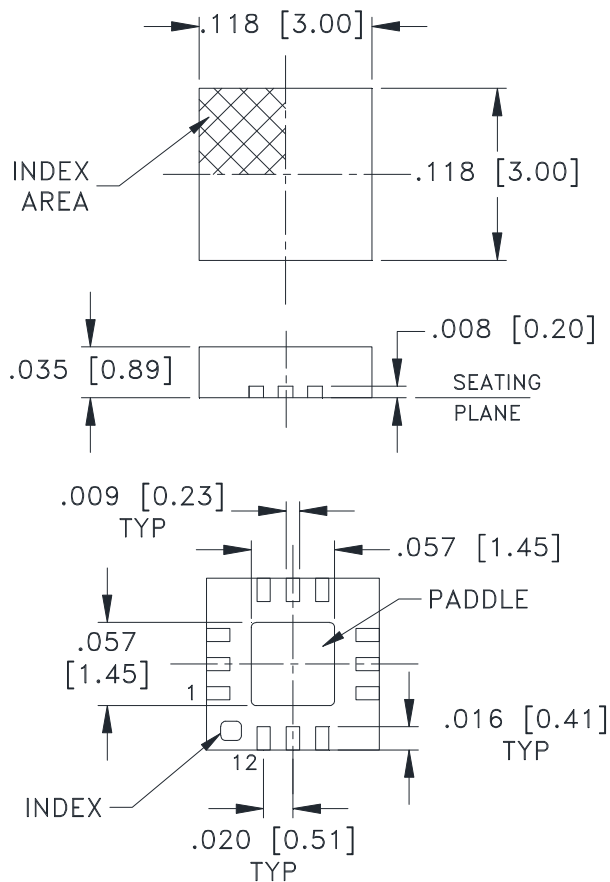

PCB Land Pattern

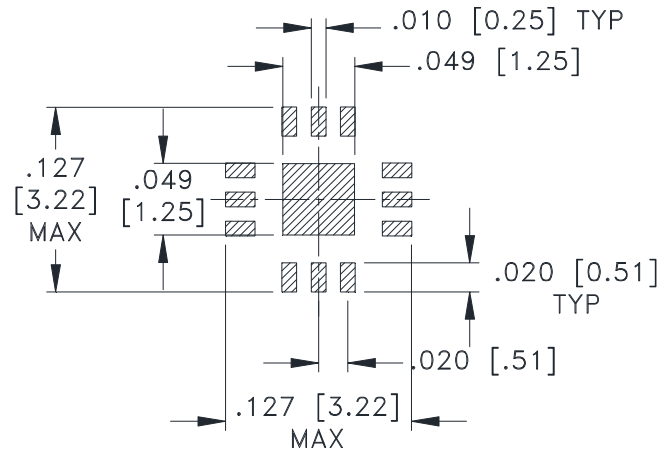

SUGGESTED LAYOUT,
TOLERANCE TO BE WITHIN $\pm .002$

Weight: .02 Grams

Dimensions are in inches (mm). Tolerances: 2Pl. $\pm .01$; 3 Pl. $\pm .004$

Notes:

1. Case material: Plastic.
2. Termination finish:
 - For RoHS Case Styles: Tin-Silver alloy plate over Nickel barrier or Matte-Tin. All models, (+) suffix. See Data sheet.
 - For RoHS-5 Case Styles: Tin-Lead plate. All models, no (+) suffix.

Mini-Circuits®

Distribution Centers NORTH AMERICA 800-654-7949 • 417-335-5935 • Fax 417-335-5945 • EUROPE 44-1252-832600 • Fax 44-1252-837010

Mini-Circuits ISO 9001 & ISO 14001 Certified

INTERNET <http://www.minicircuits.com>

P.O. Box 350166, Brooklyn, New York 11235-0003 (718) 934-4500 Fax (718) 332-4661

Tape & Reel Packaging TR-F66



Tape Width, mm	Device Cavity Pitch, mm	Reel Size, inches	Devices per Reel see note	
8	4	7	Small quantity standard	20
				50
				100
				200
				500
		7	Standard	1000, 2000, 3000

Note: Please consult individual model data sheet to determine device per reel availability.

Mini-Circuits carrier tape materials provide protection from ESD (Electro-Static Discharge) during handling and transportation. Tapes are static dissipative and comply with industry standards EIA-481/EIA-541.

Go to: www.minicircuits.com/pages/pdfs/tape.pdf

Mini-Circuits®

INTERNET <http://www.minicircuits.com>

P.O. Box 350166, Brooklyn, New York 11235-0003 (718) 934-4500 Fax (718) 332-4661

Distribution Centers NORTH AMERICA 800-654-7949 • 417-335-5935 • Fax 417-335-5945 • EUROPE 44-1252-832600 • Fax 44-1252-837010

Mini-Circuits ISO 9001 & ISO 14001 Certified

THIRD ANGLE PROJECTION

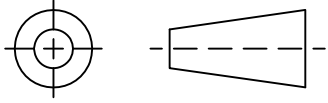

REVISIONS

REV	ECN No.	DESCRIPTION	DATE	DR	AUTH
OR	M167803	NEW RELEASE	05/11/18	ITG	RS

SUGGESTED MOUNTING CONFIGURATION
FOR DQ1225 CASE STYLE, "12AM03" PIN CODE

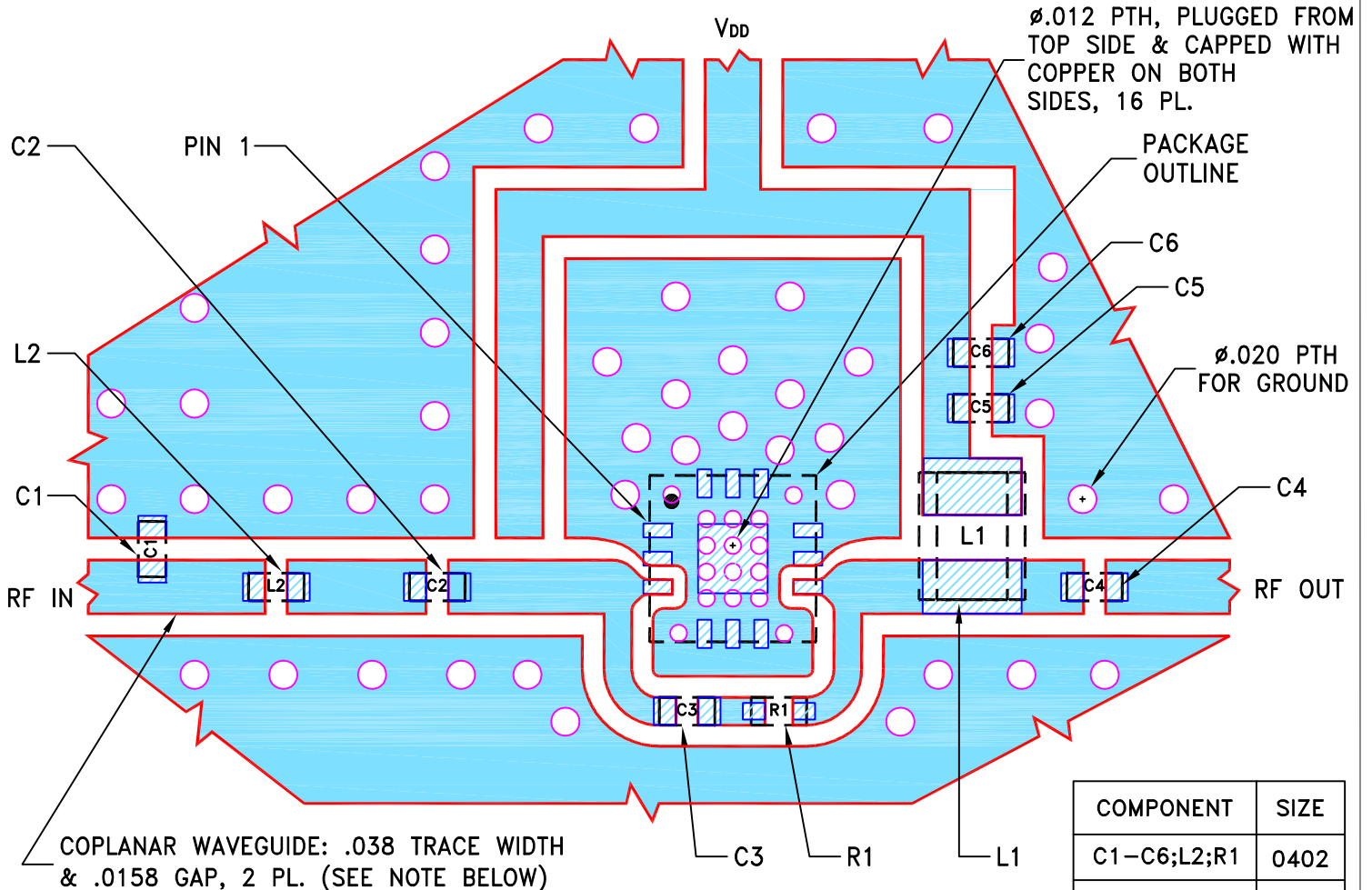

COMPONENT	SIZE
C1-C6;L2;R1	0402
L1	0805

NOTES:

- TRACE WIDTH & GAP PARAMETERS ARE SHOWN FOR ROGERS R04350B WITH DIELECTRIC THICKNESS .020"±.0015". COPPER: 1/2 OZ. EACH SIDE. FOR OTHER MATERIALS TRACE WIDTH & GAP MAY NEED TO BE MODIFIED.
- CHIP COMPONENT FOOT PRINTS SHOWN FOR REFERENCE. FOR COMPONENT VALUES REFER TO TB-1061-23LN+ OR TB-1061-23HLN+, WHICHEVER IS APPLICABLE.
- BOTTOM SIDE OF THE PCB IS CONTINUOUS GROUND PLANE.

- DENOTES PCB COPPER LAYOUT WITH SMOBC (SOLDER MASK OVER BARE COPPER).
- DENOTES COPPER LAND PATTERN FREE OF SOLDER MASK.

UNLESS OTHERWISE SPECIFIED	INITIALS	DATE
DIMENSIONS ARE IN INCHES	DRAWN ITG	05/09/18
TOLERANCES ON:	CHECKED IL	05/11/18
2 PL DECIMALS ±	APPROVED RS	05/11/18
3 PL DECIMALS ± .005		
ANGLES ±		
FRACTIONS ±		

Mini-Circuits® 13 Neptune Avenue
Brooklyn NY 11235

PL, 12AM03, DQ1225, TB-1061-23(H)LN+

Mini-Circuits®
THIS DOCUMENT AND ITS CONTENTS ARE THE PROPERTY OF MINI-CIRCUITS. EXCEPT FOR USE EXPRESSLY GRANTED, IN WRITING, TO ITS VENDORS, VENDEE AND THE UNITED STATES GOVERNMENT, MINI-CIRCUITS RESERVES ALL PROPRIETARY DESIGN, USE, MANUFACTURING AND REPRODUCTION RIGHTS THERETO. THESE CONTENTS SHALL NOT BE USED, DUPLICATED OR DISCLOSED TO ANY OUTSIDE PARTY, IN WHOLE OR IN PART, WITHOUT WRITTEN PERMISSION OF MINI-CIRCUITS.

SIZE	CODE IDENT	DRAWING NO:	REV:
A	15542	98-PL-587	OR
FILE:	98PL587	SCALE: 8:1	SHEET: 1 OF 1

Evaluation Board and Circuit

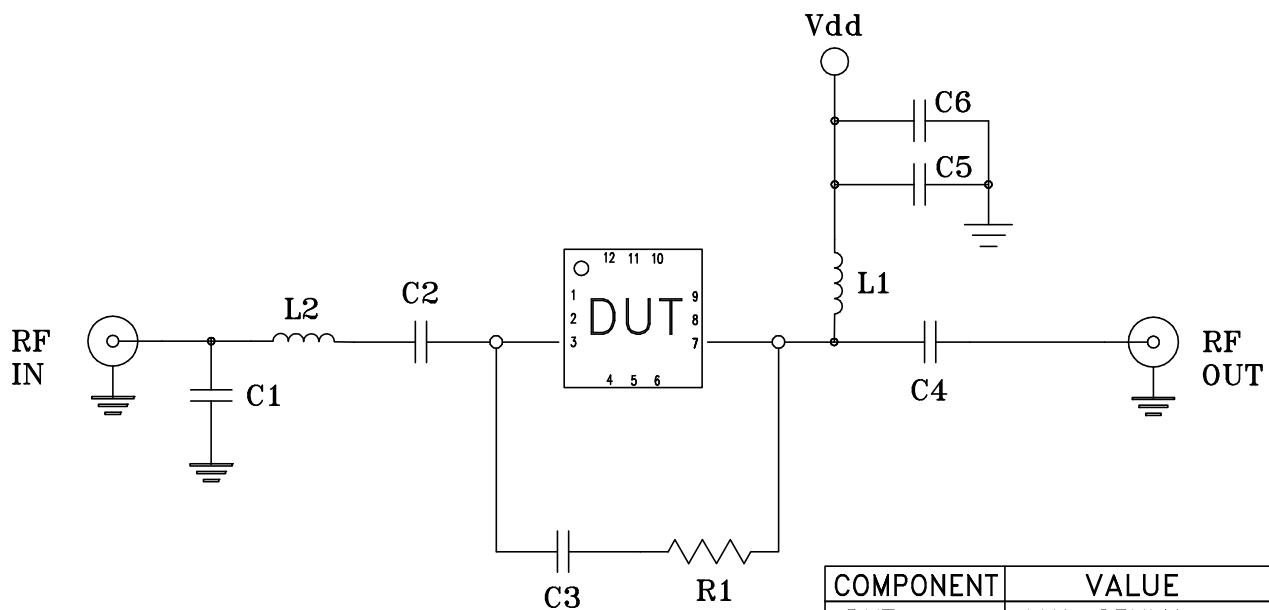
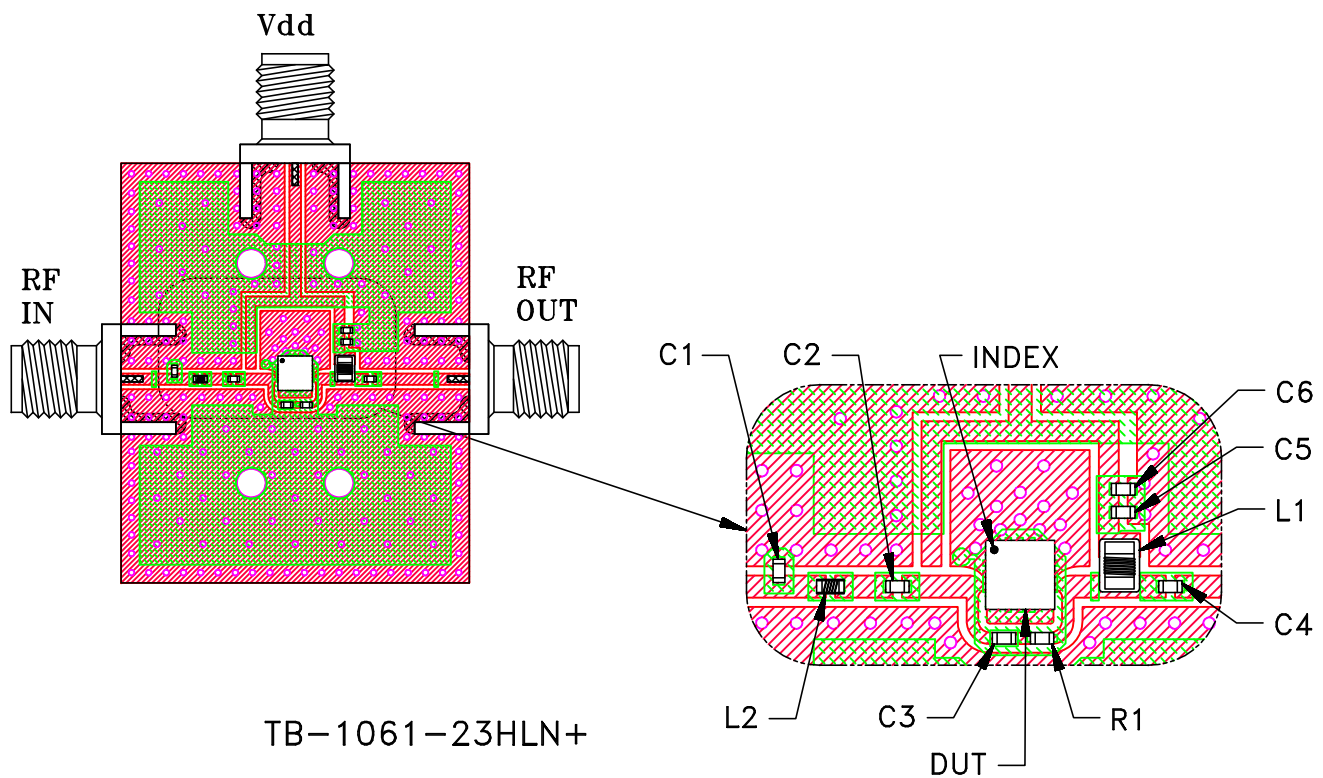

Schematic Diagram

COMPONENT	VALUE	SIZE
DUT	LHA-23HLN+	3X3 MM
C1	Capacitor 1.2 pF	0402
C2,C3,C6	Capacitor 0.1 uF	
C4	Capacitor 0.001 uF	
C5	Capacitor 0.01 uF	
R1	Resistor 1.21 KOhm	
L1	Inductor 0.680 uH	0805
L2	Inductor 1.0 nH	0402

Notes:

1. 50 Ohm SMA Female connectors.
2. PCB Material: R04350 or equivalent,
Dielectric Constant=3.5, Thickness=.020 inch.

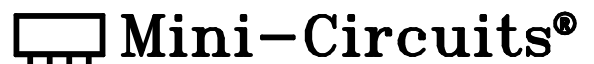



All Mini-Circuits products are manufactured under exacting quality assurance and control standards, and are capable of meeting published specifications after being subjected to any or all of the following physical and environmental test.

Specification	Test/Inspection Condition	Reference/Spec
Operating Temperature	-40° to 95° C / 105° C Ambient Environment	Individual Model Data Sheet
Storage Temperature	-55° to 100° C or -65° to 150° Ambient Environment	Individual Model Data Sheet
Thermal Shock	-55° to 100°C, 100 cycles	MIL-STD-202, Method 107, Condition A-3, except +100°C
Mechanical Shock	1.5Kg, 0.5 ms, 5 shock pulses, Y1 direction only	MIL-STD-883, Method 2002, Condition B, except Y1 direction only
Vibration (Variable Frequency)	50g peak	MIL-STD-883, Method 2007, Condition B
Autoclave	15 psig, 100% RH, 121°C, 96 hours	JESD22-A102-C, Condition C
HAST	130°C, 85% RH, 96 hours	JESD22-A110
Solderability	10X Magnification	J-STD-002, Para 4.2.5, Test S, 95% Coverage
Solder Reflow Heat	Sn-Pb Eutetic Process: 240°C peak Pb-Free Process: 260°C peak	J-STD-020C, Table 4-1, 4-2 and 5-2; Figure 5-1
Moisture Sensitivity: Level 1	Bake at 125°C for 24 hours. Soak at 85°C/85%RH for 168 hours Reflow 3 cycles at 260°C peak	J-STD-020
Marking Resistance to Solvents	Isopropyl alcohol + mineral spirits at 25°C; terpene defluxer at 25°C; distilled water + proylene glycol monomethyl ether +	MIL-STD-202, Method 215



All Mini-Circuits products are manufactured under exacting quality assurance and control standards, and are capable of meeting published specifications after being subjected to any or all of the following physical and environmental test.

Specification	Test/Inspection Condition	Reference/Spec
	monoethanolamine at 63°C to 70°C	