

X2 Frequency Multiplier

LK-3000+

50Ω Output 140 to 3000 MHz



Generic photo used for illustration purposes only

CASE STYLE: BB48

+RoHS Compliant

The +Suffix identifies RoHS Compliance. See our web site for RoHS Compliance methodologies and qualifications

Maximum Ratings

Operating Temperature	-55°C to 100°C
Storage Temperature	-55°C to 100°C
RF Input Power	200mW
Permanent damage may occur if any of these limits are exceeded.	

Pin Connections

INPUT	4
OUTPUT	8
GROUND	1,2,3,5,6,7
CASE GROUND	1,2,3,5,6,7

Outline Drawing

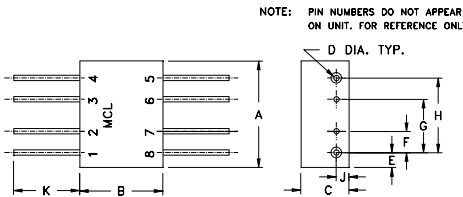

Outline Dimensions (inch/mm)

A	B	C	D	E	F
.50	.39	.225	.025	.07	.100
12.70	9.91	5.72	0.64	1.78	2.54
G	H	J	K	wt	
.250	.350	.06	.31		grams
6.35	8.89	1.52	7.87		3.0

Features

- wideband, 140 to 3000 MHz
- low conversion loss, 11 dB typ.
- drop-in flat pack

Applications

- synthesizers
- local oscillators

Electrical Specifications

MULTIPLICATION FACTOR	FREQUENCY (MHz)		INPUT POWER (dBm)		CONVERSION LOSS (dB)		*HARMONIC OUTPUT (dBc)					
	F1 Input	F2 Output	Min.	Max.	Typ.	Max.	F1		F3		F4	
2	70-1000	140-2000	12	15	10.5	14.0	31	20	40	25	15	10
	1000-1500	2000-3000	12	15	11.5	16.0	22	15	35	20	20	14

* Harmonics of input frequency below the power level of F2

Typical Performance Data

Input Frequency (MHz)	Conversion Loss (dB) F2	Harmonic Output (-dBc)		
		F1	F3	F4
70.00	10.32	49.20	51.20	15.70
100.00	10.54	50.60	54.20	15.60
200.00	10.39	43.70	54.10	16.90
450.00	10.94	34.30	46.80	15.60
500.00	10.91	34.80	47.80	14.90
700.00	10.69	29.70	43.40	16.90
900.00	10.56	28.10	39.50	23.10
1000.00	10.82	25.80	33.90	21.70
1200.00	12.43	25.10	42.90	25.60
1500.00	13.30	21.90	29.70	40.20

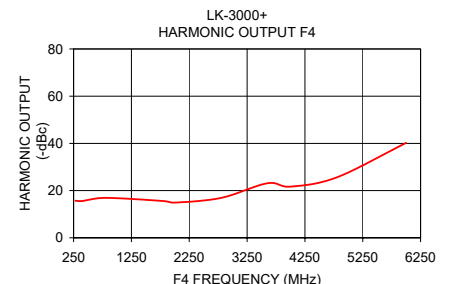
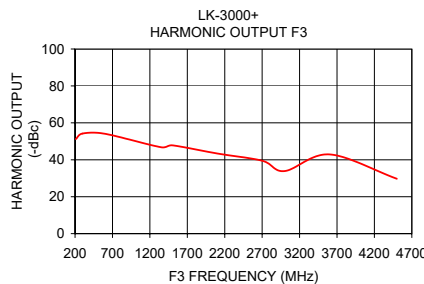
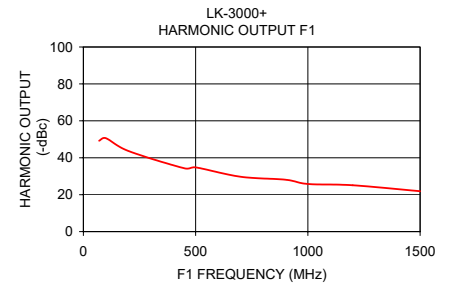
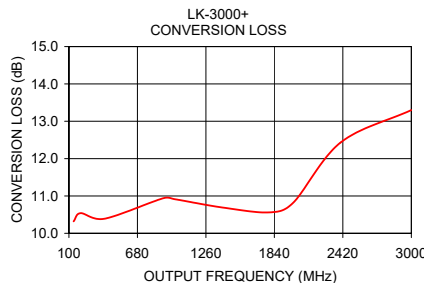

Notes

- Performance and quality attributes and conditions not expressly stated in this specification document are intended to be excluded and do not form a part of this specification document.
- Electrical specifications and performance data contained in this specification document are based on Mini-Circuit's applicable established test performance criteria and measurement instructions.
- The parts covered by this specification document are subject to Mini-Circuits standard limited warranty and terms and conditions (collectively, "Standard Terms"); Purchasers of this part are entitled to the rights and benefits contained therein. For a full statement of the Standard Terms and the exclusive rights and remedies thereunder, please visit Mini-Circuits' website at www.minicircuits.com/MCLStore/terms.jsp



Frequency Multiplier (Doublers)

LK-3000+

Typical Performance Data

FREQUENCY (MHz)				CONVERSION LOSS (dB)	HARMONIC OUTPUT*		
X 1 OUTPUT	X 2 OUTPUT	X 3 OUTPUT	X 4 OUTPUT		X 1 OUTPUT	X 3 OUTPUT	X 4 OUTPUT
70	140	210	280	10.32	49.20	51.20	15.70
100	200	300	400	10.54	50.60	54.20	15.60
200	400	600	800	10.39	43.70	54.10	16.90
450	900	1350	1800	10.94	34.30	46.80	15.60
500	1000	1500	2000	10.91	34.80	47.80	14.90
700	1400	2100	2800	10.69	29.70	43.40	16.90
900	1800	2700	3600	10.56	28.10	39.50	23.10
1000	2000	3000	4000	10.82	25.80	33.90	21.70
1200	2400	3600	4800	12.43	25.10	42.90	25.60
1500	3000	4500	6000	13.30	21.90	29.70	40.20

*Harmonic Output below power level of X 2 Output .



Frequency Multiplier (Doubler)

LK-3000+

Typical Performance Curves

Conversion Loss X 2 Output

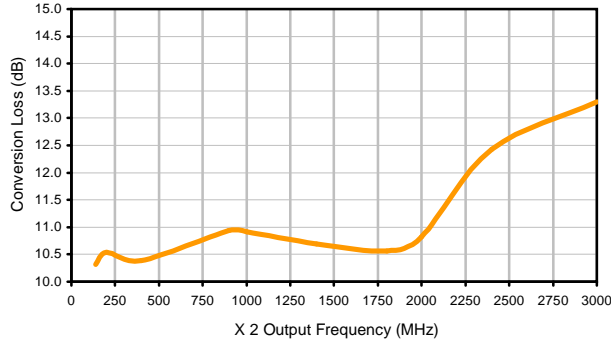

Harmonic X 1 Output

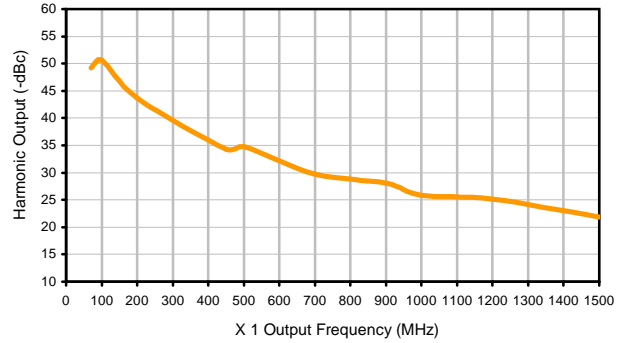

Harmonic X 3 Output

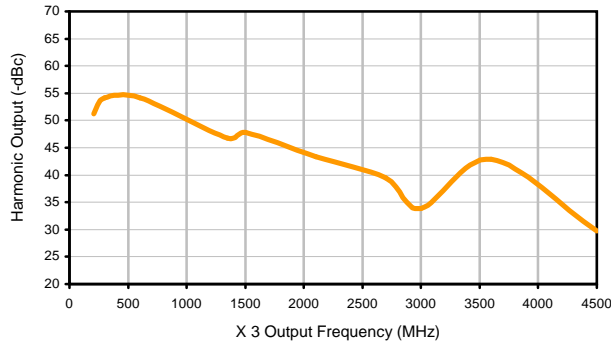

Harmonic X 4 Output

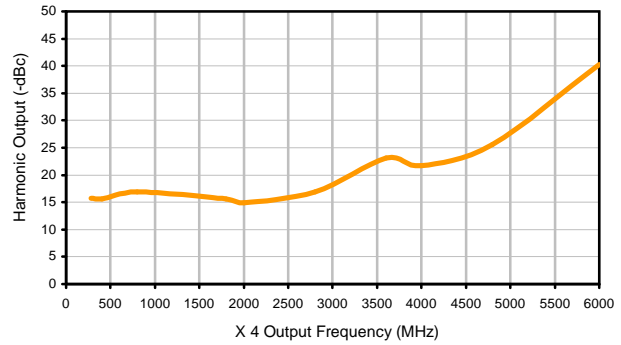

NOTE: PIN NUMBERS DO NOT APPEAR ON UNIT. FOR REFERENCE ONLY.

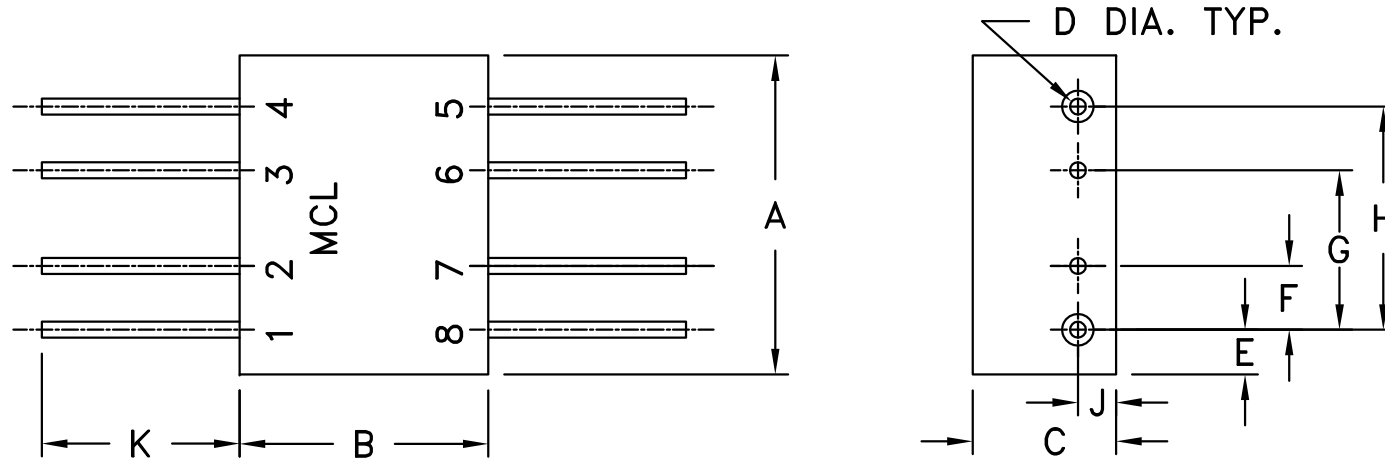

CASE NO.	A	B	C	D	E	F	G	H	J	K	NOTES	WT. GRAMS
BB48	.50 (12.70)	.39 (9.91)	.225 (5.72)	.025 (0.63)	.07 (1.78)	.100 (2.54)	.250 (6.35)	.350 (8.89)	.06 (1.52)	.31 (7.87)	A1,E1	3.0

REFER TO GN-219 FOR TEXT OF NOTES.

UNLESS OTHERWISE SPECIFIED DIMENSIONS ARE IN INCHES TOLERANCES ON: 2 PL. DECIMALS ± .03 3 PL. DECIMALS ± .015 ANGLES ± FRACTIONS ±	INITIALS	DATE
	DRAWN PM	10.16.95
	CHECKED	
APPROVED		
<input checked="" type="checkbox"/> Mini-Circuits <small>THIS DOCUMENT AND ITS CONTENTS ARE THE PROPERTY OF MINI-CIRCUITS LABORATORY. EXCEPT FOR USE EXPRESSLY GRANTED, IN WRITING, TO ITS VENDORS, VENDORS AND THE UNITED STATES GOVERNMENT, MINI-CIRCUITS LABORATORY RESERVES ALL PROPRIETARY DESIGN, USE, MANUFACTURING AND REPRODUCTION RIGHTS THEREOF. THESE CONTENTS SHALL NOT BE USED, DUPLICATED OR DISCLOSED TO ANY OUTSIDE PARTY, IN WHOLE OR IN PART, WITHOUT WRITTEN PERMISSION OF MINI-CIRCUITS.</small>		
BSHEETA1.DWG REV:A DATE:01/12/94		

 **Mini-Circuits** Mini-Circuit Laboratory
13 Neptane Avenue
Brooklyn NY 11235

CATALOG OUTLINE "BB"

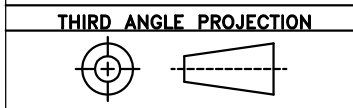

OR	M42441	CHANGED PART NO.	PM
REV	ECN No.	DESCRIPTION	DATE DR AUTH
REVISIONS			

SIZE	CODE IDENT	DRAWING NO:	REV:
B	15542	98-BB	OR
FILE:	98-BB	SCALE: NONE	SHEET: 1 OF 1

All Mini-Circuits products are manufactured under exacting quality assurance and control standards, and are capable of meeting published specifications after being subjected to any or all of the following physical and environmental test.

Specification	Test/Inspection Condition	Reference/Spec
Operating Temperature	-55° to 100° C Ambient Environment	Individual Model Data Sheet
Storage Temperature	-55° to 100° C Ambient Environment	Individual Model Data Sheet
Thermal Shock	-55° to 100°C, 100 cycles	MIL-STD-202, Method 107, Condition A-3, except +100°C
Vibration (High Frequency)	20g peak, 10-2000 Hz, 12 times in each of three perpendicular directions (total 36)	MIL-STD-202, Method 204, Condition D
Mechanical Shock	50g, 11 ms, 1/2-sine, 18 shocks: 3 each direction, each of 3 axes	MIL-STD-202, Method 213, Condition A
Moisture Resistance	10 cycles, 24 hours per cycle	MIL-STD-202, Method 106, Condition A, except 50°C and end point electrical test done within 12 hours
Solderability	10X Magnification	J-STD-002, 95% Coverage
Resistance to Solder Heat	260°C for 10 seconds	MIL-STD-202, Method 210, Condition B
Marking Resistance to Solvents	Isopropyl alcohol + mineral spirits at 25°C; terpene defluxer at 25°C; distilled water + proylene glycol monomethyl ether + monoethanolamine at 63°C to 70°C	MIL-STD-202, Method 215
Terminal Strength	4 1/2 Pound Pull	MIL-STD-202, Method 211, Condition A



All Mini-Circuits products are manufactured under exacting quality assurance and control standards, and are capable of meeting published specifications after being subjected to any or all of the following physical and environmental test.

Specification	Test/Inspection Condition	Reference/Spec
Gross Leak	125°C Bubble Test	MIL-STD-202, Method 112, Condition D
Barometric Pressure	100,000 Feet	MIL-STD-202, Method 105, Condition D