

Non-Catalog Model

Frequency Mixer

LRMS-5R

Level 7 (LO Power +7 dBm)

Important Note

This is a non-catalog model and can be manufactured on specific request. Pricing and delivery information can be supplied upon request.



Please click "Back", and then click "Contact Us" for Applications support.

CASE STYLE : QQQ130

| ELECTRICAL SPECIFICATIONS 50Ω @ +25°C | | | | | |
|---------------------------------------|---------------|------|------|------|-------|
| Parameter | | Min. | Typ. | Max. | Units |
| Frequency | LO (fL to fU) | 10 | | 1500 | MHz |
| | RF (fL to fU) | 10 | | 1500 | MHz |
| | IF | 0 | | 1000 | MHz |
| Conversion Loss | mid band | | 5.6 | 8.0 | dB |
| | Total Range | | | 9.9 | dB |
| LO-RF Isolation | Low Range | 40 | 50 | | dB |
| | Mid Range | 20 | 34 | | dB |
| | Upper Range | 18 | 22 | | dB |
| LO-IF Isolation | Low Range | 27 | 50 | | dB |
| | Mid Range | 15 | 30 | | dB |
| | Upper Range | 7 | 14 | | dB |
| 1 dB Comp. Input Power | | | +1 | | dBm |

Notes: Low Range = [fL to 10fL]
mid band = [2fL to fU/2]

Mid Range = [10fL to fU/2]

Upper Range = [fU/2 to fU]

Phase detection, positive polarity

Hermetic sealed diodes

| MAXIMUM RATINGS | |
|-----------------------|----------------|
| Operating Temperature | -40°C to 85°C |
| Storage Temperature | -55°C to 100°C |
| RF Power | 50mW |
| IF Current | 40mA |

Electrical Schematics

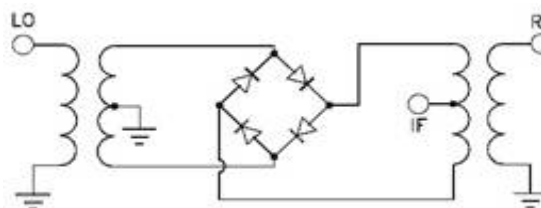

| PIN CONNECTIONS | |
|-----------------|---------|
| LO | 1 |
| RF | 4 |
| IF | 5 |
| GROUND | 2, 3, 6 |

Frequency Mixer

LRMS-5R

Typical Performance Data

| RF (MHz) | LO (MHz) | CONVERSION LOSS (dB) | | | LO (MHz) | LO-RF ISOLATION (dB) | | | LO-IF ISOLATION (dB) | | |
|-------------|-------------|-------------------------|------|------|-------------|-------------------------|------|------|-------------------------|------|------|
| | | @LO (dBm) | | | | @LO (dBm) | | | @LO (dBm) | | |
| | | +10 | +13 | +16 | | +10 | +13 | +16 | +10 | +13 | +16 |
| 5.0 | 35.0 | 6.56 | 6.17 | 5.95 | 5.0 | 77.6 | 78.3 | 78.5 | 69.0 | 82.1 | 77.0 |
| 10.0 | 40.0 | 6.45 | 6.03 | 5.79 | 10.0 | 71.7 | 73.1 | 73.9 | 63.3 | 75.4 | 72.8 |
| 20.0 | 50.0 | 6.30 | 5.86 | 5.58 | 20.0 | 65.8 | 67.4 | 68.7 | 56.9 | 67.3 | 69.1 |
| 50.0 | 80.0 | 5.86 | 5.46 | 5.27 | 50.0 | 58.2 | 60.2 | 62.0 | 49.8 | 61.2 | 60.2 |
| 100.0 | 70.0 | 5.65 | 5.31 | 5.14 | 100.0 | 51.8 | 53.7 | 55.7 | 43.7 | 53.9 | 54.9 |
| 149.7 | 119.7 | 5.65 | 5.33 | 5.15 | 149.7 | 48.1 | 50.1 | 51.9 | 40.1 | 50.8 | 51.0 |
| 200.0 | 170.0 | 5.67 | 5.37 | 5.22 | 200.0 | 45.7 | 47.5 | 49.4 | 37.7 | 48.2 | 48.9 |
| 246.1 | 216.1 | 5.89 | 5.54 | 5.34 | 246.1 | 44.0 | 45.9 | 47.8 | 36.2 | 48.7 | 44.3 |
| 342.6 | 312.6 | 6.12 | 5.71 | 5.44 | 342.6 | 41.2 | 43.1 | 45.0 | 34.6 | 48.7 | 38.4 |
| 439.0 | 409.0 | 6.17 | 5.77 | 5.51 | 439.0 | 38.9 | 40.8 | 42.4 | 34.2 | 43.8 | 33.7 |
| 500.0 | 470.0 | 6.52 | 5.97 | 5.64 | 500.0 | 37.8 | 39.7 | 41.6 | 35.2 | 38.4 | 30.8 |
| 583.7 | 553.7 | 6.87 | 6.25 | 5.90 | 583.7 | 36.9 | 39.2 | 41.5 | 35.7 | 33.2 | 27.5 |
| 680.2 | 650.2 | 7.26 | 6.55 | 6.09 | 680.2 | 35.9 | 38.3 | 40.2 | 33.8 | 29.3 | 24.5 |
| 750.0 | 720.0 | 7.71 | 6.89 | 6.36 | 750.0 | 35.6 | 37.6 | 38.9 | 30.6 | 26.8 | 23.2 |
| 873.1 | 843.1 | 8.22 | 7.45 | 6.96 | 873.1 | 34.7 | 36.9 | 37.9 | 25.2 | 21.6 | 19.4 |
| 1000.0 | 970.0 | 8.19 | 7.70 | 7.38 | 1000.0 | 33.2 | 35.5 | 37.0 | 20.9 | 18.1 | 16.1 |
| 1114.2 | 1084.2 | 8.20 | 7.76 | 7.48 | 1114.2 | 31.8 | 33.7 | 35.3 | 18.4 | 16.3 | 14.7 |
| 1210.6 | 1180.6 | 8.39 | 8.02 | 7.78 | 1210.6 | 30.7 | 32.5 | 33.8 | 16.5 | 15.0 | 13.4 |
| 1355.3 | 1325.3 | 8.78 | 8.41 | 8.25 | 1355.3 | 29.0 | 30.9 | 32.3 | 14.1 | 13.3 | 12.2 |
| 1500.0 | 1470.0 | 9.59 | 8.83 | 8.49 | 1500.0 | 26.9 | 28.6 | 29.9 | 12.8 | 12.3 | 11.5 |

REV. X1
LRMS-5R
060612
Page 1 of 2



IF/RF MICROWAVE COMPONENTS • ISO 9001 ISO 14001 AS 9100 CERTIFIED RoHS compliant
P.O. Box 350166, Brooklyn, New York 11235-0003 (718) 934-4500 Fax (718) 332-4661



The Design Engineers Search Engine finds the model you need, Instantly • For detailed performance specs & shopping online see



Frequency Mixer

LRMS-5R

Typical Performance Data

| RF/LO (MHz) | RF VSWR (:1) | | | LO VSWR (:1) | | | IF (MHz) | IF VSWR (:1) | | | LO/RF (MHz) | max. DC output (mV) | DC Offset (mV) |
|----------------|-----------------|------|------|-----------------|------|------|-------------|-----------------|------|------|----------------|------------------------------|----------------------|
| | @LO (dBm) | | | @LO (dBm) | | | | @LO (dBm) | | | @LO (dBm) | | |
| | +10 | +13 | +16 | +10 | +13 | +16 | | +10 | +13 | +16 | +13 | | |
| 5.0 | 2.73 | 2.64 | 2.55 | 1.68 | 2.43 | 3.47 | 5.0 | 1.51 | 1.21 | 1.03 | 5.0 | 221.9 | -0.01 |
| 10.0 | 1.68 | 1.62 | 1.58 | 1.67 | 2.43 | 3.47 | 10.0 | 1.52 | 1.22 | 1.03 | 10.0 | 231.0 | -0.01 |
| 20.0 | 1.45 | 1.37 | 1.32 | 1.62 | 2.37 | 3.38 | 20.0 | 1.52 | 1.22 | 1.03 | 20.0 | 233.7 | -0.01 |
| 50.0 | 1.38 | 1.27 | 1.19 | 1.71 | 2.46 | 3.47 | 50.0 | 1.52 | 1.21 | 1.03 | 50.0 | 231.2 | 0.00 |
| 100.0 | 1.41 | 1.29 | 1.20 | 1.63 | 2.38 | 3.29 | 100.0 | 1.53 | 1.22 | 1.04 | 100.0 | 236.2 | 0.06 |
| 149.7 | 1.47 | 1.34 | 1.24 | 1.60 | 2.33 | 3.27 | 149.7 | 1.53 | 1.22 | 1.05 | 149.7 | 244.2 | 0.17 |
| 200.0 | 1.53 | 1.40 | 1.30 | 1.63 | 2.28 | 3.20 | 200.0 | 1.53 | 1.22 | 1.06 | 200.0 | 238.7 | 0.31 |
| 246.1 | 1.61 | 1.48 | 1.37 | 1.62 | 2.29 | 3.15 | 246.1 | 1.52 | 1.22 | 1.06 | 246.1 | 241.3 | 0.63 |
| 342.6 | 1.82 | 1.68 | 1.57 | 1.70 | 2.29 | 3.12 | 342.6 | 1.51 | 1.21 | 1.07 | 342.6 | 239.7 | 1.04 |
| 439.0 | 2.09 | 1.93 | 1.80 | 1.79 | 2.33 | 3.12 | 439.0 | 1.46 | 1.19 | 1.07 | 439.0 | 206.1 | 1.79 |
| 500.0 | 2.27 | 2.10 | 1.96 | 1.86 | 2.41 | 3.19 | 500.0 | 1.43 | 1.17 | 1.07 | 500.0 | 203.6 | 2.00 |
| 583.7 | 2.56 | 2.36 | 2.22 | 1.96 | 2.48 | 3.27 | 583.7 | 1.35 | 1.13 | 1.09 | 583.7 | 208.7 | 3.07 |
| 680.2 | 2.96 | 2.71 | 2.52 | 2.12 | 2.69 | 3.40 | 680.2 | 1.25 | 1.08 | 1.15 | 680.2 | 199.2 | 4.09 |
| 750.0 | 3.17 | 2.92 | 2.74 | 2.25 | 2.80 | 3.59 | 750.0 | 1.10 | 1.14 | 1.30 | 750.0 | 193.3 | 5.44 |
| 873.1 | 3.56 | 3.32 | 3.14 | 2.54 | 3.09 | 3.90 | 873.1 | 1.07 | 1.23 | 1.40 | 873.1 | 192.0 | 6.35 |
| 1000.0 | 3.73 | 3.56 | 3.40 | 2.73 | 3.20 | 3.82 | 1000.0 | 1.36 | 1.57 | 1.75 | 1000.0 | 200.9 | 5.97 |
| 1114.2 | 3.76 | 3.69 | 3.53 | 2.81 | 3.18 | 3.93 | 1114.2 | 1.81 | 2.02 | 2.23 | 1114.2 | 188.0 | 5.59 |
| 1210.6 | 3.79 | 3.73 | 3.66 | 2.95 | 3.19 | 3.94 | 1210.6 | 2.36 | 2.60 | 2.82 | 1210.6 | 183.6 | 5.78 |
| 1355.3 | 3.78 | 3.75 | 3.73 | 3.15 | 3.12 | 4.13 | 1355.3 | 3.52 | 3.78 | 4.03 | 1355.3 | 192.0 | 6.69 |
| 1500.0 | 3.86 | 3.83 | 3.80 | 3.29 | 2.98 | 4.30 | 1500.0 | 4.99 | 5.07 | 5.22 | 1500.0 | 185.9 | 8.33 |

REV. X1
LRMS-5R
060612
Page 2 of 2



IF/RF MICROWAVE COMPONENTS • ISO 9001 ISO 14001 AS 9100 CERTIFIED RoHS compliant
P.O. Box 350166, Brooklyn, New York 11235-0003 (718) 934-4500 Fax (718) 332-4661



The Design Engineers Search Engine finds the model you need, Instantly • For detailed performance specs & shopping online see



Typical Performance Curves

Conversion Loss

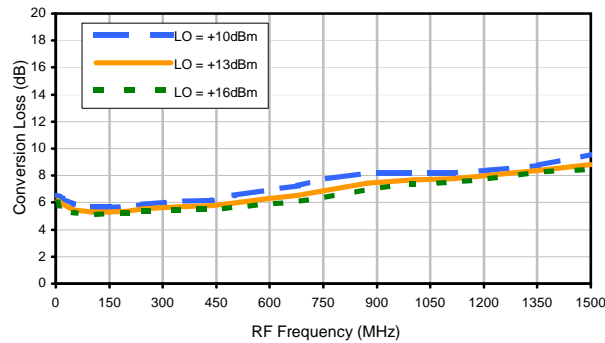

LO-RF Isolation

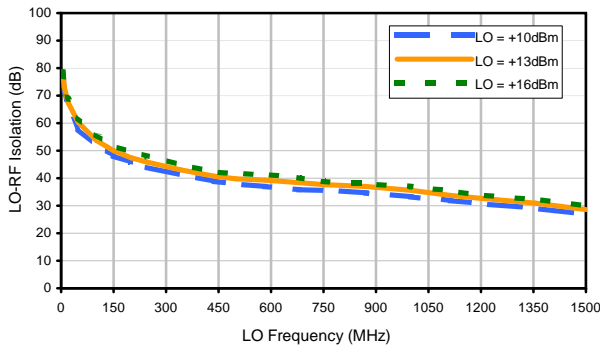

LO-IF Isolation

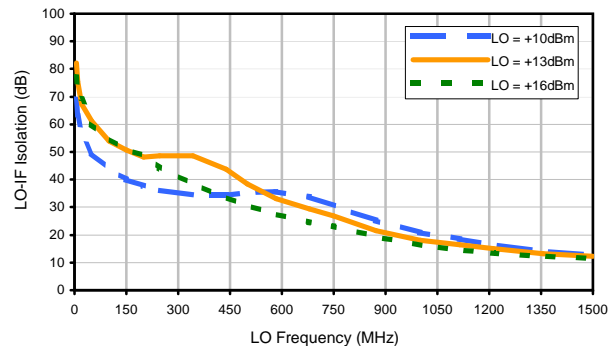

RF VSWR

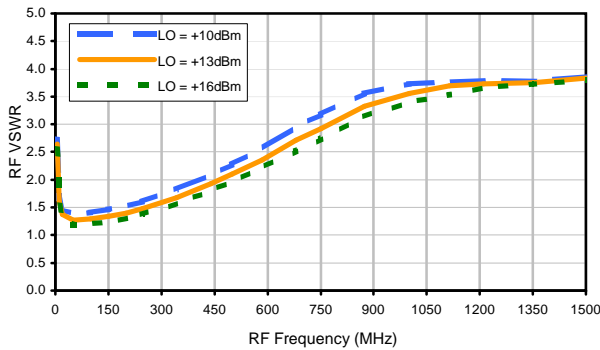

LO VSWR

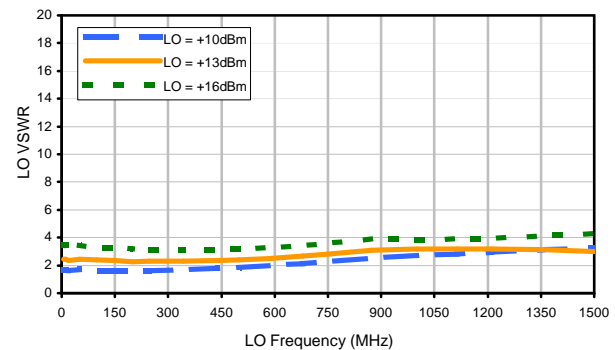

IF VSWR

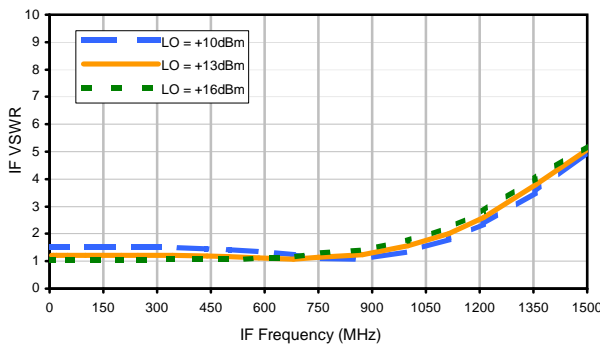

Max. DC Output

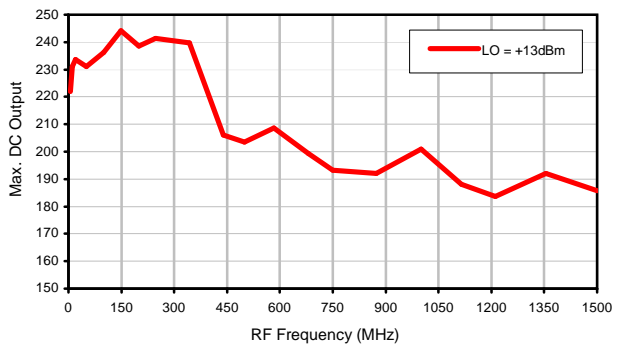

Case Style

QQQ

QQQ130 (non-waterproof)
QQQ828 (washable)

Outline Dimensions

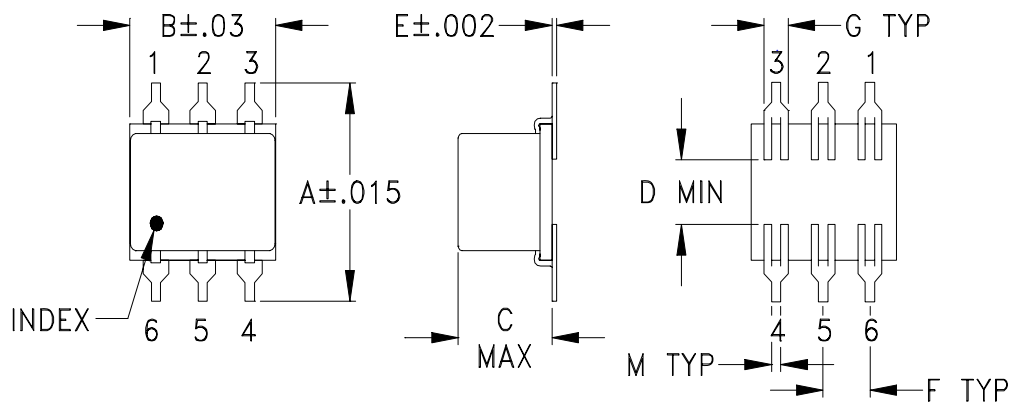

PCB Land Pattern

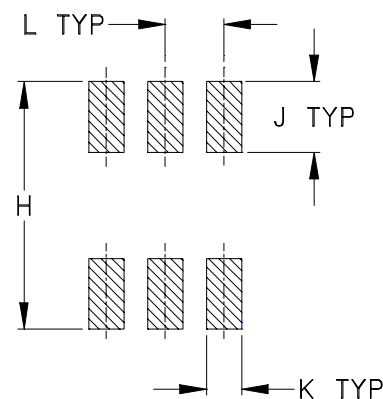

Suggested Layout,
Tolerance to be within $\pm .002$

| CASE# | A | B | C | D | E | F | G | H | J | K | L | M | WT, GRAM |
|--------|-----------------|---------------|----------------|---------------|---------------|----------------|----------------|-----------------|----------------|----------------|----------------|---------------|----------|
| QQQ130 | .400 (10.16) | .31 (7.87) | .200 (5.08) | .10 (2.54) | .010 (.25) | .100 (2.54) | .050 (1.27) | .420 (10.67) | .120 (3.05) | .060 (1.52) | .100 (2.54) | .020 (.51) | .55 |
| QQQ828 | | | .050 (1.27) | | | | | | | | | | .20 |

Dimensions are in inches (mm). Tolerances: 2 Pl. $\pm .01$; 3 Pl. $\pm .005$

Notes:

- Case material: Ceramic.
- Termination finish:
 - For RoHS Case Styles: Tin plate over Nickel plate.
 - For RoHS-5 Case Styles: Tin-Lead plate.



INTERNET <http://www.minicircuits.com>

P.O. Box 350166, Brooklyn, New York 11235-0003 (718) 934-4500 Fax (718) 332-4661

Distribution Centers NORTH AMERICA 800-654-7949 • 417-335-5935 • Fax 417-335-5945 • EUROPE 44-1252-832600 • Fax 44-1252-837010

Mini-Circuits ISO 9001 & ISO 14001 Certified

Tape & Reel Packaging TR-F10

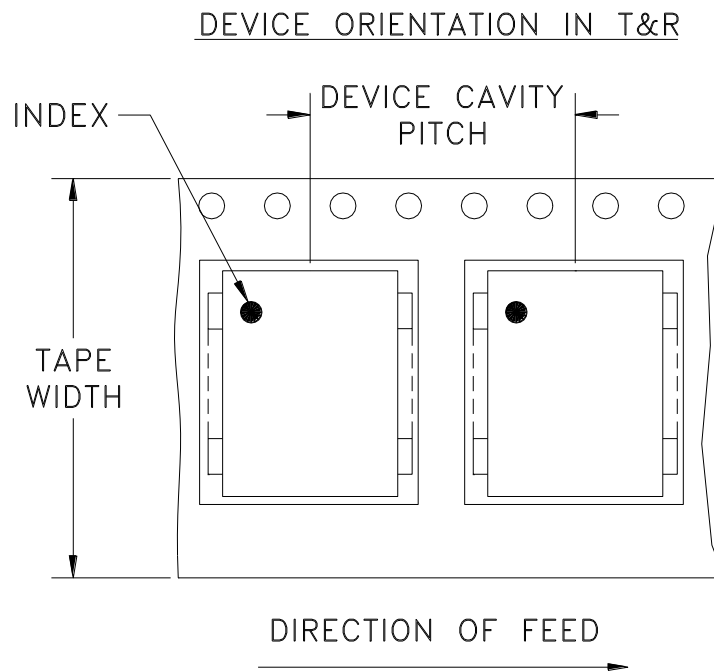

| Tape Width, mm | Device Cavity Pitch, mm | Reel Size, inches | Devices per Reel |
|----------------|-------------------------|-------------------|------------------|
| 24 | 16 | 7 | 10,20,50,100 |
| | | 13 | 200,500 |

Mini-Circuits carrier tape materials provide protection from ESD (Electro-Static Discharge) during handling and transportation. Tapes are static dissipative and comply with industry standards EIA-481/EIA-541.

Go to: www.minicircuits.com/pages/pdfs/tape.pdf

Note: Please consult individual model data sheet to determine device per reel availability.



INTERNET <http://www.minicircuits.com>

P.O. Box 350166, Brooklyn, New York 11235-0003 (718) 934-4500 Fax (718) 332-4661

Distribution Centers NORTH AMERICA 800-654-7949 • 417-335-5935 • Fax 417-335-5945 • EUROPE 44-1252-832600 • Fax 44-1252-837010

Mini-Circuits ISO 9001 & ISO 14001 Certified

THIRD ANGLE PROJECTION

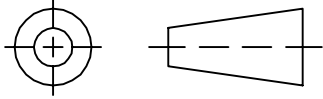

REVISIONS

| REV | ECN No. | DESCRIPTION | DATE | DR | AUTH |
|-----|---------|---------------|----------|----|------|
| OR | M82272 | NEW RELEASE | 08/02/02 | AV | DJ |
| A | M102713 | UPDATED NOTES | 01/14/06 | GF | IL |
| | | | | | |

SUGGESTED MOUNTING CONFIGURATION FOR QQQ569 CASE STYLE, "w" PIN CONNECTION

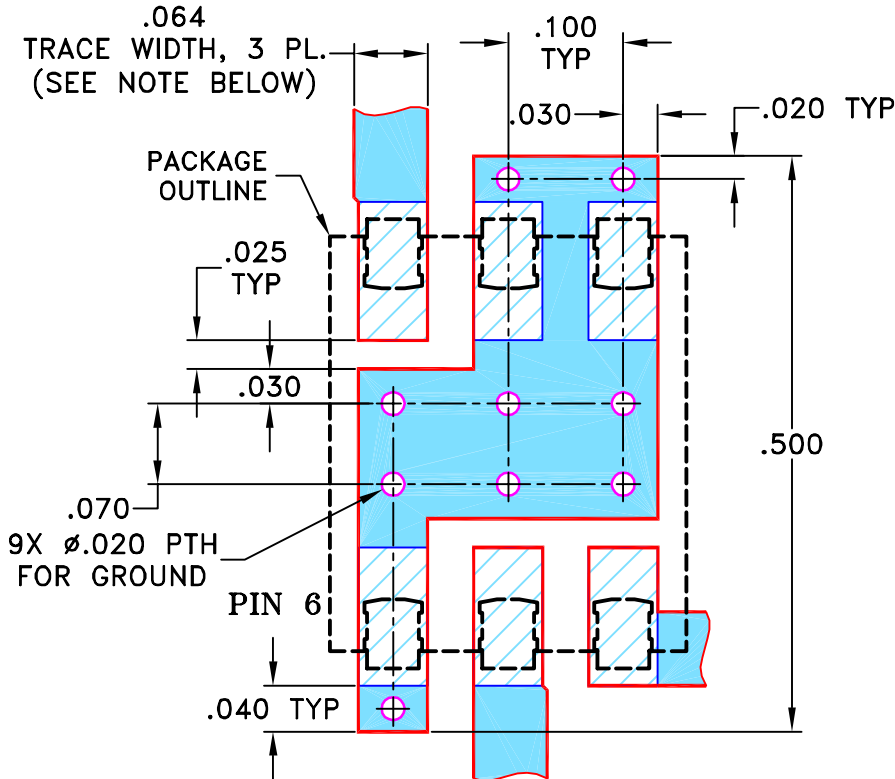

NOTES: 1. TRACE WIDTH IS SHOWN FOR ROGERS RO4350B WITH DIELECTRIC THICKNESS 0.030" ± 0.002"; COPPER: 1/2 OZ. EACH SIDE. FOR OTHER MATERIALS TRACE WIDTH MAY NEED TO BE MODIFIED.

2. BOTTOM SIDE OF THE PCB IS CONTINUOUS GROUND PLANE.



DENOTES PCB COPPER LAYOUT WITH SMOBC (SOLDER MASK OVER BARE COPPER)



DENOTES COPPER LAND PATTERN FREE OF SOLDER MASK

UNLESS OTHERWISE SPECIFIED

INITIALS

DATE

DIMENSIONS ARE IN INCHES

DRAWN

AV

07/19/02

TOLERANCES ON:

CHECKED

WL

08/02/02

2 PL DECIMALS ± .005

APPROVED

DJ

08/02/02

3 PL DECIMALS ±

ANGLES ±

FRACTIONS ±

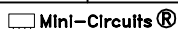

THIS DOCUMENT AND ITS CONTENTS ARE THE PROPERTY OF MINI-CIRCUITS. EXCEPT FOR USE EXPRESSLY GRANTED, IN WRITING, TO ITS VENDORS, VENDEE AND THE UNITED STATES GOVERNMENT, MINI-CIRCUITS RESERVES ALL PROPRIETARY DESIGN, USE, MANUFACTURING AND REPRODUCTION RIGHTS THERETO. THESE CONTENTS SHALL NOT BE USED, DUPLICATED OR DISCLOSED TO ANY OUTSIDE PARTY, IN WHOLE OR IN PART, WITHOUT WRITTEN PERMISSION OF MINI-CIRCUITS.



Mini-Circuits®

13 Neptune Avenue
Brooklyn NY 11235

PL, w, QQQ569, LRMS-J, TB-44

SIZE

CODE IDENT

DRAWING NO:

REV:

A

15542

98-PL-083

A

FILE: 98PL083

SCALE: 6:1

SHEET: 1 OF 1

ASHEETA1.DWG REV:A DATE:01/12/95

Evaluation Board and Circuit

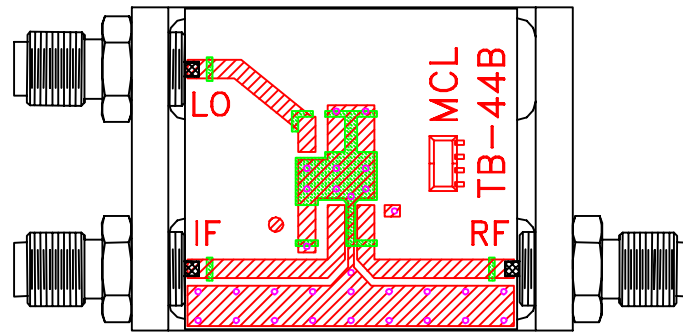

TB-44+

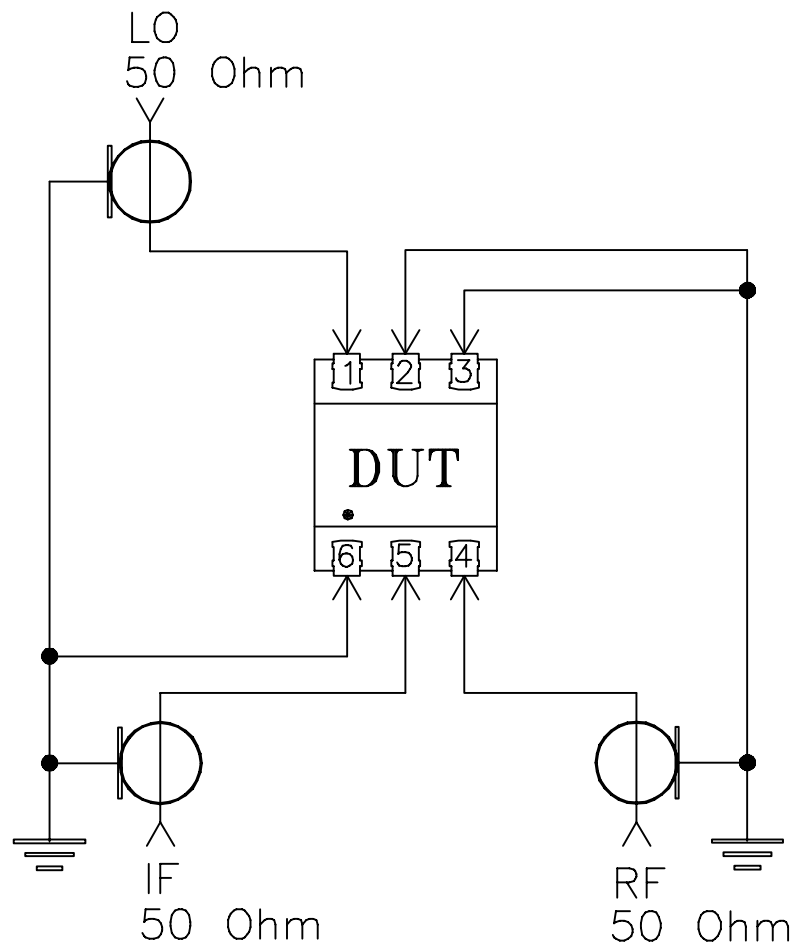

Schematic Diagram

Notes:

1. SMA Female connectors.
2. PCB Material: Rogers R04350 or equivalent,
Dielectric Constant=3.5, Thickness=.030 inch.

 Mini-Circuits®