

# Engineering Development Model

## Frequency Mixer

## MBR-EE7756/21

Level 13 (LO Power +13 dBm)

### Important Note

This model has been designed, built and tested in our engineering department. Performance data represents model capability. At present it is a non-catalog model. On request, we can supply a final specification sheet, part number and price/delivery information.



Please click "Back", and then click "Contact Us" for Applications support.

**CASE STYLE : SM26**

ELECTRICAL SPECIFICATIONS 50Ω @ +25°C					
Parameter		Min.	Typ.	Max.	Units
Frequency	LO (fL to fU)	1200		3007	MHz
	RF (fL to fU)	1200		3007	MHz
	IF	0.1		750	MHz
Conversion Loss			5.9		dB
LO-RF Isolation			25		dB
LO-IF Isolation			15		dB

MAXIMUM RATINGS	
Operating Temperature	-40°C to 85°C
Storage Temperature	-55°C to 100°C

PIN CONNECTIONS	
LO	6
RF	3
IF	2
GROUND	1, 4, 5

# Frequency Mixer

# MBR-EE7756/21

## Typical Performance Data

RF (MHz)	LO (MHz)	CONVERSION LOSS (dB)			LO (MHz)	LO-RF ISOLATION (dB)			LO-IF ISOLATION (dB)		
		@LO (dBm)				@LO (dBm)			@LO (dBm)		
		+10	+13	+16		+10	+13	+16	+10	+13	+16
1200.0	1230.0	7.18	6.88	6.68	1230.0	29.2	33.4	38.3	18.0	16.0	15.0
1209.3	1239.3	6.97	6.67	6.47	1239.3	29.1	32.8	37.8	17.9	16.1	15.1
1250.0	1280.0	6.65	6.35	6.25	1280.0	28.1	31.8	35.6	18.0	16.3	15.2
1300.0	1330.0	6.15	5.95	5.85	1330.0	27.0	30.7	34.9	18.6	16.9	16.2
1350.0	1380.0	5.74	5.64	5.64	1380.0	25.9	29.4	33.0	18.7	17.5	16.9
1400.0	1430.0	5.49	5.49	5.49	1430.0	24.6	28.0	31.3	18.4	17.9	17.7
1434.0	1464.0	5.40	5.40	5.40	1464.0	24.1	27.2	30.6	18.2	18.3	18.4
1500.0	1530.0	5.59	5.39	5.39	1530.0	22.1	25.7	28.8	17.7	18.6	19.1
1550.0	1580.0	5.57	5.37	5.27	1580.0	22.5	26.2	29.2	17.3	18.8	20.1
1600.0	1630.0	5.51	5.41	5.31	1630.0	23.4	26.6	28.1	16.7	18.4	19.7
1620.0	1650.0	5.50	5.30	5.30	1650.0	23.4	26.2	27.7	16.5	18.1	19.4
1658.7	1688.7	5.46	5.36	5.36	1688.7	22.9	25.3	26.3	16.3	17.6	18.8
1700.0	1730.0	5.57	5.37	5.37	1730.0	22.5	24.6	25.2	15.9	17.1	18.0
1750.0	1780.0	5.54	5.34	5.34	1780.0	22.5	24.2	24.6	15.7	16.6	17.0
1800.0	1830.0	5.60	5.50	5.40	1830.0	22.4	23.6	23.8	15.3	15.9	16.2
1850.0	1880.0	5.80	5.60	5.60	1880.0	21.9	22.7	22.8	15.1	15.3	15.2
1883.3	1913.3	5.85	5.75	5.65	1913.3	21.7	22.1	22.0	15.0	15.0	14.8
1900.0	1930.0	5.90	5.80	5.80	1930.0	21.7	21.9	21.7	14.9	14.8	14.4
1970.0	2000.0	5.94	5.84	5.94	2000.0	22.0	21.6	21.1	15.1	14.5	14.0
2000.0	2030.0	5.92	5.92	5.92	2030.0	21.9	21.4	20.7	15.2	14.6	13.8
2108.0	2138.0	5.79	5.79	5.89	2138.0	22.0	21.0	20.1	14.6	13.8	13.0
2332.7	2362.7	6.87	7.27	7.57	2362.7	20.3	19.1	18.5	12.4	11.6	11.2
2557.3	2587.3	7.52	7.22	7.22	2587.3	21.6	21.1	20.5	9.7	9.4	9.4
2782.0	2812.0	6.29	6.19	6.19	2812.0	21.8	22.4	22.4	8.4	8.9	9.3
3006.7	3036.7	6.14	5.94	5.84	3036.7	23.8	23.5	22.7	6.9	7.5	8.0

# Frequency Mixer

# MBR-EE7756/21

## Typical Performance Data

RF/LO (MHz)	RF VSWR (:1)			LO VSWR (:1)			IF (MHz)	IF VSWR (:1)		
	@LO (dBm)			@LO (dBm)				@LO (dBm)		
	+10	+13	+16	+10	+13	+16		+10	+13	+16
1230.0	3.50	3.21	3.01	3.38	3.57	4.03	0.1	1.46	1.59	1.70
1239.3	3.32	3.06	2.88	3.32	3.44	3.95	0.5	1.43	1.56	1.65
1280.0	3.06	2.84	2.68	3.06	3.32	3.86	1.0	1.41	1.54	1.65
1330.0	2.76	2.61	2.52	2.61	2.96	3.50	5.0	1.43	1.56	1.66
1380.0	2.40	2.32	2.23	2.18	2.68	3.38	10.0	1.44	1.57	1.68
1430.0	2.12	2.03	1.94	1.89	2.46	3.16	30.0	1.43	1.56	1.65
1464.0	1.91	1.82	1.76	1.73	2.30	2.92	50.0	1.43	1.56	1.66
1530.0	1.63	1.57	1.54	1.51	2.08	2.68	57.6	1.45	1.58	1.68
1580.0	1.46	1.47	1.49	1.35	1.88	2.46	70.0	1.44	1.58	1.68
1630.0	1.32	1.36	1.38	1.21	1.64	2.12	100.0	1.45	1.57	1.66
1650.0	1.30	1.33	1.36	1.19	1.56	2.03	115.1	1.48	1.60	1.70
1688.7	1.22	1.25	1.28	1.17	1.49	1.96	172.6	1.52	1.62	1.70
1730.0	1.14	1.19	1.23	1.21	1.41	1.77	200.0	1.55	1.66	1.74
1780.0	1.05	1.13	1.19	1.30	1.43	1.77	230.1	1.58	1.67	1.73
1830.0	1.06	1.11	1.17	1.41	1.51	1.84	287.6	1.61	1.68	1.73
1880.0	1.16	1.17	1.22	1.60	1.67	1.99	300.0	1.61	1.66	1.70
1913.3	1.21	1.22	1.27	1.75	1.81	2.16	345.1	1.63	1.65	1.68
1930.0	1.23	1.25	1.30	1.82	1.89	2.27	375.0	1.65	1.64	1.65
2000.0	1.31	1.33	1.38	1.89	2.03	2.46	400.0	1.68	1.65	1.65
2030.0	1.32	1.33	1.38	1.91	2.04	2.49	402.6	1.68	1.65	1.64
2138.0	1.37	1.30	1.29	1.87	2.12	2.58	460.1	1.84	1.77	1.73
2362.7	2.06	2.06	2.04	1.81	2.32	2.84	500.0	1.99	1.89	1.84
2587.3	3.44	3.26	2.84	1.81	2.46	3.11	517.6	2.10	1.99	1.92
2812.0	2.43	2.23	2.04	1.73	2.16	2.55	575.1	2.43	2.27	2.20
3036.7	1.92	1.70	1.59	1.89	2.12	2.37	600.0	2.58	2.43	2.35

## Typical Performance Curves

Conversion Loss

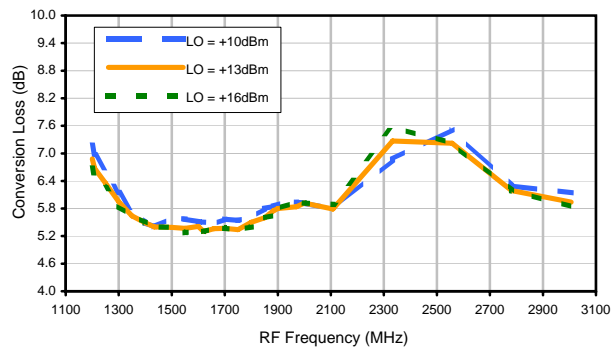

LO-RF Isolation

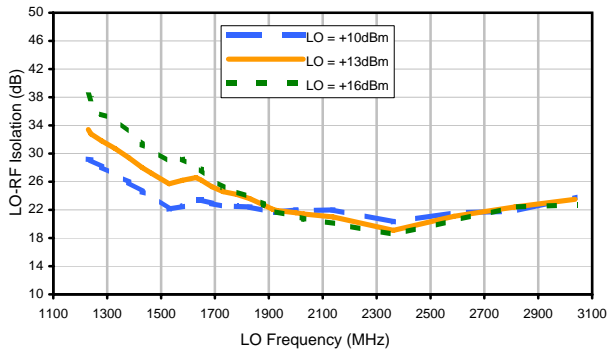

LO-IF Isolation

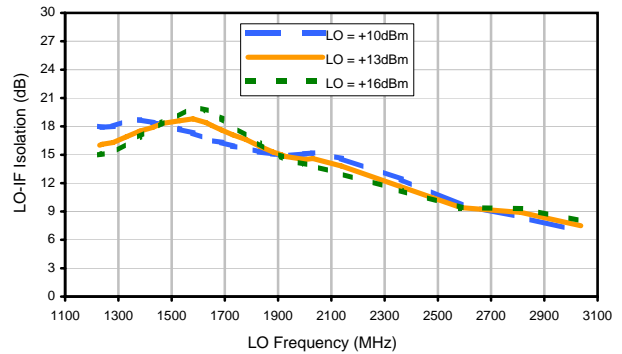

RF VSWR

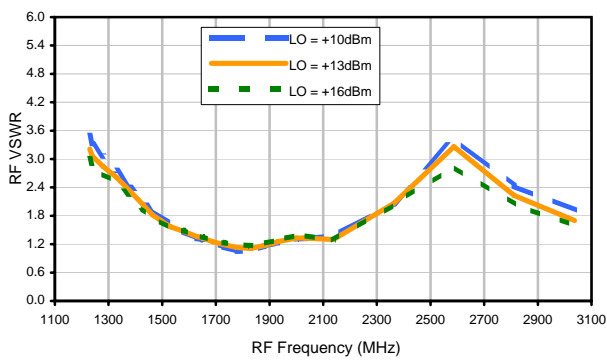

LO VSWR

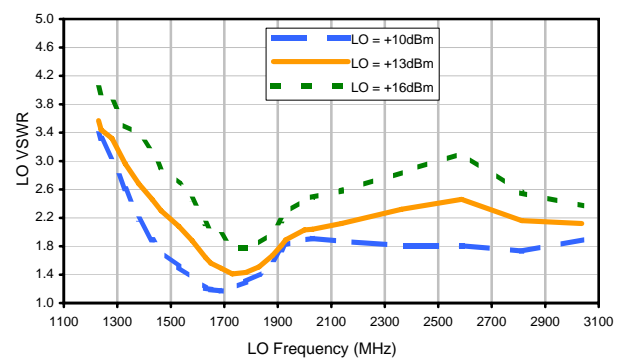

IF VSWR

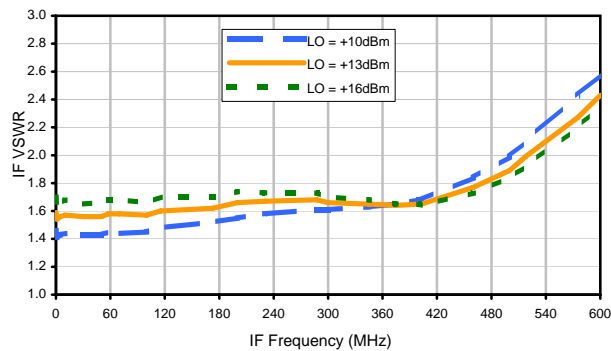

### Outline Dimensions

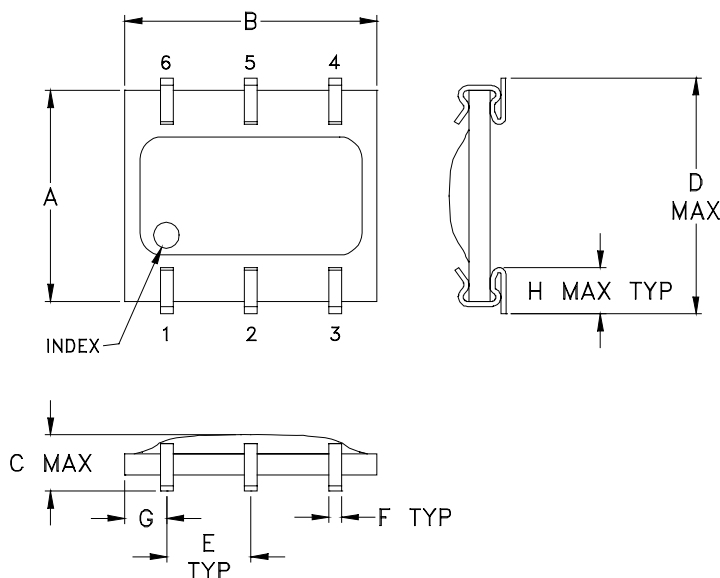

### PCB Land Pattern

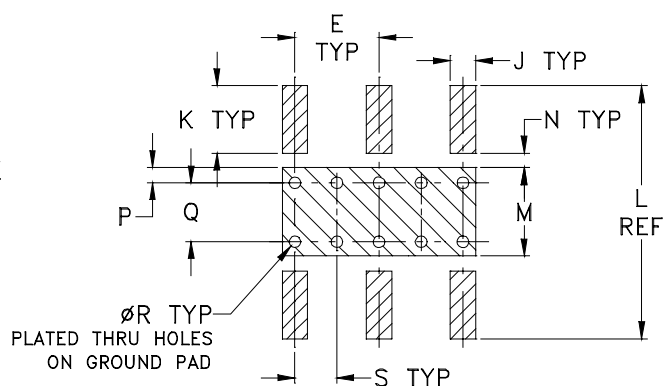

### Suggested Layout,

Tolerance to be within  $\pm .002$   
 ADJACENT GROUND PINS SHALL BE CONNECTED  
 TO EACH OTHER AND TO GROUND PAD

CASE#	A	B	C	D	E	F	G	H	J	K	L	M	N
SM26	.250 (6.35)	.300 (7.62)	.095 (2.41)	.290 (7.37)	.100 (2.54)	.015 (.38)	.050 (1.27)	.060 (1.52)	.030 (.76)	.080 (2.03)	.300 (7.62)	.100 (2.54)	.020 (.51)

CASE#	P	Q	R	S	WT, GRAM
SM26	.015 (.38)	.070 (1.78)	.014 (.36)	.050 (1.27)	.3

Dimensions are in inches (mm). Tolerances: 2 Pl.  $\pm .005$ ; 3 Pl.  $\pm .005$

### Notes:

- Case material: Plastic encapsulation on Ceramic base.
- Termination finish:  
 For RoHS Case Styles: Tin plate over Nickel plate.  
 For RoHS-5 Case Styles: Tin-Lead plate.

# Tape & Reel Packaging TR-F34



Tape Width, mm	Device Cavity Pitch, mm	Reel Size, inches	Devices per Reel see note	
16	12	7	Small quantity standard (see note)	20
				50
				100
				200
		13	Standard	500
				1000

Note: Availability of small reel quantity varies by model.  
Refer to pricing and availability on individual model dashboard.

Mini-Circuits carrier tape materials provide protection from ESD (Electro-Static Discharge) during handling and transportation. Tapes are static dissipative and comply with industry standards EIA-481/EIA-541.

Go to: [www.minicircuits.com/pages/pdfs/tape.pdf](http://www.minicircuits.com/pages/pdfs/tape.pdf)



INTERNET <http://www.minicircuits.com>

P.O. Box 350166, Brooklyn, New York 11235-0003 (718) 934-4500 Fax (718) 332-4661

Distribution Centers NORTH AMERICA 800-654-7949 • 417-335-5935 • Fax 417-335-5945 • EUROPE 44-1252-832600 • Fax 44-1252-837010

Mini-Circuits ISO 9001 & ISO 14001 Certified

All Mini-Circuits products are manufactured under exacting quality assurance and control standards, and are capable of meeting published specifications after being subjected to any or all of the following physical and environmental test.

Specification	Test/Inspection Condition	Reference/Spec
Operating Temperature	-40° to 85°C Ambient Environment	Individual Model Data Sheet
Storage Temperature	-55° to 100° C Ambient Environment	Individual Model Data Sheet
Humidity	90 to 95% RH, 240 hours, 50°C	MIL-STD-202, Method 103, Condition A, Except 50°C and end-point electrical test done within 12 hours
Thermal Shock	-55° to 100°C, 100 cycles	MIL-STD-202, Method 107, Condition A-3, except +100°C
Solder Reflow Heat	Sn-Pb Eutetic Process: 225°C peak Pb-Free Process 245° - 250°C peak	J-STD-020, Table 4-1, 4-2 and 5-2, Figure 5-1
Solderability	10X Magnification	J-STD-002, 95% Coverage
Vibration (High Frequency)	20g peak, 10-2000 Hz, 12 times in each of three perpendicular directions (total 36)	MIL-STD-202, Method 204, Condition D
Mechanical Shock	50g, 11 ms, 1/2-sine, 18 shocks: 3 each direction, each of 3 axes	MIL-STD-202, Method 213, Condition A
Marking Resistance to Solvents	Isopropyl alcohol + mineral spirits at 25°C; terpene defluxer at 25°C; distilled water + proylene glycol monomethyl ether + monoethanolamine at 63°C to 70°C	MIL-STD-202, Method 215