

Engineering Development Model

Frequency Mixer

MBR-EE7756/4

Level 4 (LO Power +4 dBm)

Important Note

This model has been designed, built and tested in our engineering department. Performance data represents model capability. At present it is a non-catalog model. On request, we can supply a final specification sheet, part number and price/delivery information.



Please click "Back", and then click "Contact Us" for Applications support.

CASE STYLE : SM26

ELECTRICAL SPECIFICATIONS 50Ω @ +25°C					
Parameter		Min.	Typ.	Max.	Units
Frequency	LO (fL to fU)	2000		4900	MHz
	RF (fL to fU)	2000		4900	MHz
	IF	0.1		1425	MHz
Conversion Loss			6.0		dB
LO-RF Isolation			36		dB
LO-IF Isolation			19		dB

MAXIMUM RATINGS	
Operating Temperature	-40°C to 85°C
Storage Temperature	-55°C to 100°C

PIN CONNECTIONS	
LO	6
RF	3
IF	2
GROUND	1, 4, 5

Frequency Mixer

MBR-EE7756/4

Typical Performance Data

RF (IN) (MHz)	LO (MHz)	CONVERSION LOSS IF FIXED @IF(OUT)=30MHz (dB)			RF (IN) (MHz)	LO (MHz)	IP3 INPUT (dBm)			RF (IN) (MHz)	LO (MHz)	COMPRESSION @RF IN=0dBm (dB)		
		@LO (dBm)					@LO (dBm)					@LO (dBm)		
		+1	+4	+7			+1	+4	+7			+1	+4	+7
1500.0	1530.0	13.19	11.73	11.30	1500.0	1530.0	15.90	11.67	8.75	1500.0	1530.0	0.22	0.32	0.42
1600.0	1630.0	11.40	10.41	10.01	1600.0	1630.0	10.49	8.27	6.49	1600.0	1630.0	0.53	0.60	0.69
1700.0	1730.0	10.17	9.47	9.04	1700.0	1730.0	7.82	7.20	6.92	1700.0	1730.0	0.64	0.61	0.73
1800.0	1830.0	9.20	8.66	8.24	1800.0	1830.0	6.95	7.11	7.63	1800.0	1830.0	0.69	0.56	0.68
1900.0	1930.0	8.47	7.97	7.56	1900.0	1930.0	6.49	8.03	9.36	1900.0	1930.0	0.81	0.58	0.62
2000.0	2030.0	7.83	7.29	6.92	2000.0	2030.0	8.60	11.53	11.90	2000.0	2030.0	0.96	0.67	0.56
2100.0	2130.0	7.24	6.79	6.56	2100.0	2130.0	9.65	10.25	10.88	2100.0	2130.0	1.00	0.59	0.46
2200.0	2230.0	6.79	6.47	6.30	2200.0	2230.0	8.39	9.59	11.56	2200.0	2230.0	1.01	0.61	0.50
2300.0	2330.0	6.55	6.25	6.12	2300.0	2330.0	6.64	8.39	10.94	2300.0	2330.0	1.06	0.63	0.56
2400.0	2430.0	6.46	6.23	6.21	2400.0	2430.0	7.32	8.93	11.41	2400.0	2430.0	1.05	0.57	0.41
2480.0	2510.0	6.57	6.34	6.33	2480.0	2510.0	8.19	9.81	10.92	2480.0	2510.0	1.08	0.55	0.33
2580.0	2610.0	6.75	6.43	6.33	2580.0	2610.0	7.84	8.57	9.76	2580.0	2610.0	1.17	0.68	0.41
2660.0	2690.0	6.70	6.25	6.07	2660.0	2690.0	6.22	7.19	8.34	2660.0	2690.0	1.41	0.95	0.67
2760.0	2790.0	6.53	6.06	5.87	2760.0	2790.0	5.13	6.05	7.56	2760.0	2790.0	1.55	1.08	0.79
2840.0	2870.0	6.40	5.91	5.71	2840.0	2870.0	5.54	6.41	7.66	2840.0	2870.0	1.49	1.05	0.76
2940.0	2970.0	6.37	5.90	5.69	2940.0	2970.0	5.85	6.87	7.88	2940.0	2970.0	1.35	0.93	0.66
3020.0	3050.0	6.38	5.92	5.71	3020.0	3050.0	6.53	7.63	8.63	3020.0	3050.0	1.36	0.92	0.66
3120.0	3150.0	6.42	5.99	5.79	3120.0	3150.0	7.56	8.61	9.90	3120.0	3150.0	1.29	0.81	0.58
3200.0	3230.0	6.47	6.07	5.89	3200.0	3230.0	9.13	10.14	11.26	3200.0	3230.0	1.20	0.68	0.45
3300.0	3330.0	6.40	6.01	5.91	3300.0	3330.0	10.95	14.16	14.77	3300.0	3330.0	1.49	0.80	0.49
3380.0	3410.0	7.31	6.68	6.35	3380.0	3410.0	8.73	9.22	9.94	3380.0	3410.0	1.37	1.03	0.81
3480.0	3510.0	7.17	6.69	6.42	3480.0	3510.0	8.00	8.87	9.82	3480.0	3510.0	1.06	0.82	0.66
3560.0	3590.0	7.11	6.70	6.47	3560.0	3590.0	8.47	9.27	10.35	3560.0	3590.0	1.03	0.73	0.58
3660.0	3690.0	7.14	6.75	6.51	3660.0	3690.0	9.40	9.80	10.58	3660.0	3690.0	0.93	0.63	0.49
3740.0	3770.0	7.10	6.72	6.50	3740.0	3770.0	9.33	9.72	10.63	3740.0	3770.0	0.96	0.63	0.49
3840.0	3870.0	7.15	6.78	6.57	3840.0	3870.0	9.82	10.05	10.91	3840.0	3870.0	0.93	0.57	0.44
3920.0	3950.0	7.09	6.72	6.52	3920.0	3950.0	9.82	10.25	10.90	3920.0	3950.0	1.01	0.60	0.44
4020.0	4050.0	7.14	6.73	6.50	4020.0	4050.0	9.82	10.47	11.01	4020.0	4050.0	1.10	0.66	0.47
4100.0	4130.0	7.20	6.69	6.44	4100.0	4130.0	9.95	11.33	11.49	4100.0	4130.0	1.09	0.67	0.48
4200.0	4230.0	7.42	6.81	6.51	4200.0	4230.0	9.27	12.13	12.89	4200.0	4230.0	1.21	0.79	0.64
4280.0	4310.0	7.63	6.97	6.68	4280.0	4310.0	8.96	11.45	11.69	4280.0	4310.0	1.21	0.79	0.64
4380.0	4410.0	7.90	7.06	6.72	4380.0	4410.0	8.48	11.89	11.75	4380.0	4410.0	1.26	0.85	0.72
4460.0	4490.0	8.19	7.17	6.79	4460.0	4490.0	8.78	11.03	11.62	4460.0	4490.0	1.23	0.86	0.76
4560.0	4590.0	8.61	7.36	6.92	4560.0	4590.0	8.40	10.58	11.61	4560.0	4590.0	1.26	0.93	0.82
4640.0	4670.0	9.25	7.70	7.11	4640.0	4670.0	8.12	10.23	10.99	4640.0	4670.0	1.09	0.93	0.84
4740.0	4770.0	10.02	8.14	7.44	4740.0	4770.0	9.05	10.75	10.78	4740.0	4770.0	0.85	0.83	0.74
4820.0	4850.0	11.11	8.68	7.94	4820.0	4850.0	8.47	11.13	11.09	4820.0	4850.0	0.51	0.83	0.74
4920.0	4950.0	12.56	9.59	8.64	4920.0	4950.0	4.90	9.67	11.12	4920.0	4950.0	-0.25	0.60	0.67
5000.0	5030.0	13.73	10.34	9.35	5000.0	5030.0	3.11	8.11	11.08	5000.0	5030.0	-0.77	0.43	0.57
5100.0	5130.0	15.46	11.20	10.22	5100.0	5130.0	1.18	8.69	11.95	5100.0	5130.0	-1.54	0.45	0.47

Frequency Mixer

MBR-EE7756/4

Typical Performance Data

IF (OUT) (MHz)	LO (MHz)	CONVERSION LOSS VS. IF FREQUENCY @RF(IN)=3000MHz (dB)	IF (OUT) (MHz)	LO (MHz)	CONVERSION LOSS VS. IF FREQUENCY @RF(IN)=1989.9MHz (dB)	IF (OUT) (MHz)	LO (MHz)	CONVERSION LOSS VS. IF FREQUENCY @RF(IN)=4010MHz (dB)
		@LO (dBm)			@LO (dBm)			@LO (dBm)
		+4			+4			+4
1000.0	2000.0	6.96	10.1	2000.0	7.66	1810.0	2200.0	8.61
939.4	2060.6	6.97	27.6	2017.5	7.41	1770.0	2240.0	8.48
878.8	2121.2	7.16	45.1	2035.0	7.40	1730.0	2280.0	8.17
818.2	2181.8	7.42	62.6	2052.5	7.35	1690.0	2320.0	7.85
757.6	2242.4	7.64	80.1	2070.0	7.32	1650.0	2360.0	7.62
696.9	2303.1	7.76	97.6	2087.5	7.31	1610.0	2400.0	7.40
656.5	2343.5	7.76	115.1	2105.0	7.33	1570.0	2440.0	7.33
595.9	2404.1	7.70	132.6	2122.5	7.34	1530.0	2480.0	7.21
555.5	2444.5	7.54	150.1	2140.0	7.33	1490.0	2520.0	7.25
494.9	2505.1	7.29	167.6	2157.5	7.34	1450.0	2560.0	7.30
454.5	2545.5	7.04	185.1	2175.0	7.36	1410.0	2600.0	7.50
393.9	2606.1	6.74	202.6	2192.5	7.40	1370.0	2640.0	7.83
353.5	2646.5	6.53	220.1	2210.0	7.43	1330.0	2680.0	8.15
292.9	2707.1	6.28	237.6	2227.5	7.47	1290.0	2720.0	8.52
252.4	2747.6	6.18	255.1	2245.0	7.52	1250.0	2760.0	8.72
191.8	2808.2	6.04	272.6	2262.5	7.57	1210.0	2800.0	8.89
151.4	2848.6	6.07	290.1	2280.0	7.58	1170.0	2840.0	9.11
90.8	2909.2	6.03	307.6	2297.5	7.65	1110.0	2900.0	9.12
50.4	2949.6	6.01	325.1	2315.0	7.66	1070.0	2940.0	9.19
10.0	3010.0	6.44	342.6	2332.5	7.73	1010.0	3000.0	8.95
49.6	3049.6	5.98	360.1	2350.0	7.82	970.0	3040.0	8.85
109.0	3109.0	6.02	377.6	2367.5	7.83	910.0	3100.0	8.88
148.6	3148.6	6.06	395.1	2385.0	7.92	870.0	3140.0	9.02
208.0	3208.0	6.10	412.6	2402.5	7.95	810.0	3200.0	8.96
247.6	3247.6	6.01	430.1	2420.0	8.00	770.0	3240.0	8.84
307.0	3307.0	6.21	447.6	2437.5	8.23	710.0	3300.0	8.49
346.6	3346.6	6.31	465.1	2455.0	8.30	670.0	3340.0	8.31
406.0	3406.0	6.50	482.6	2472.5	8.44	610.0	3400.0	8.02
445.6	3445.6	6.59	500.1	2490.0	8.53	570.0	3440.0	7.91
505.0	3505.0	6.77	517.6	2507.5	8.61	510.0	3500.0	7.58
544.6	3544.6	6.90	535.1	2525.0	8.74	470.0	3540.0	7.44
604.0	3604.0	7.17	552.6	2542.5	8.85	410.0	3600.0	7.08
643.6	3643.6	7.36	570.1	2560.0	8.91	370.0	3640.0	6.98
703.0	3703.0	7.74	587.6	2577.5	9.04	310.0	3700.0	6.85
742.6	3742.6	7.94	605.1	2595.0	9.13	270.0	3740.0	6.78
802.0	3802.0	8.27	622.6	2612.5	9.19	210.0	3800.0	6.73
841.6	3841.6	8.39	640.1	2630.0	9.35	170.0	3840.0	6.67
901.0	3901.0	8.54	657.6	2647.5	9.38	110.0	3900.0	6.66
940.6	3940.6	8.66	692.6	2682.5	9.67	70.0	3940.0	6.67
1000.0	4000.0	8.89	710.1	2700.0	9.66	10.0	4000.0	6.85



Frequency Mixer

MBR-EE7756/4

Typical Performance Data

LO (MHz)	LO-RF ISOLATION (dB)			LO-IF ISOLATION (dB)		
	@LO (dBm)			@LO (dBm)		
	+1	+4	+7	+1	+4	+7
1500.0	31.79	30.45	31.29	9.73	10.61	11.93
1600.0	32.38	31.83	32.81	9.85	10.98	12.32
1700.0	32.80	33.59	35.20	10.16	11.29	12.28
1800.0	32.96	34.19	35.64	10.73	11.57	11.84
1900.0	33.59	35.46	37.49	11.15	11.51	11.12
2000.0	34.08	37.14	41.65	11.44	10.89	10.16
2100.0	32.97	36.14	40.64	11.82	10.99	10.09
2200.0	32.97	38.43	51.38	12.94	11.53	10.31
2300.0	33.81	43.82	44.67	13.88	11.96	10.46
2400.0	34.06	50.45	38.05	14.50	12.14	10.57
2480.0	32.75	45.77	36.85	14.89	12.47	10.78
2580.0	30.14	40.39	40.12	15.35	12.93	11.32
2660.0	28.47	37.10	45.56	15.46	13.07	11.68
2760.0	28.08	36.57	46.71	15.89	13.73	12.33
2840.0	28.38	37.83	42.28	16.21	14.30	12.97
2940.0	28.31	38.18	40.55	16.71	15.02	13.84
3020.0	29.48	40.86	39.02	16.81	15.59	14.75
3120.0	29.97	41.63	38.60	17.50	16.63	16.10
3200.0	30.39	41.95	37.71	18.25	17.79	17.23
3300.0	30.57	40.40	35.51	19.21	19.30	19.03
3380.0	29.77	37.11	46.91	20.06	20.45	20.62
3480.0	35.54	40.94	33.83	21.40	22.18	22.78
3560.0	38.38	36.77	30.63	22.71	23.86	24.76
3660.0	36.68	32.95	28.70	24.58	25.94	27.04
3740.0	34.22	30.88	27.50	25.72	27.04	28.13
3840.0	30.97	28.75	26.12	25.37	26.32	27.14
3920.0	28.96	27.17	25.13	23.98	24.40	25.17
4020.0	26.92	25.84	24.29	21.65	21.98	22.72
4100.0	25.66	25.25	23.98	19.80	19.98	20.69
4200.0	24.16	24.31	23.70	18.21	17.97	18.27
4280.0	23.32	23.48	23.08	17.88	17.65	17.92
4380.0	22.41	22.68	22.22	17.28	17.29	17.63
4460.0	22.00	22.33	22.06	16.28	16.22	16.77
4560.0	21.99	22.49	22.23	15.35	14.99	15.52
4640.0	22.16	23.14	22.86	14.59	14.22	14.39
4740.0	22.77	24.01	24.09	13.65	13.12	13.09
4820.0	23.61	24.86	25.23	12.84	12.38	12.31
4920.0	24.96	25.79	26.47	11.82	11.38	11.41
5000.0	25.69	25.91	26.70	10.94	10.75	10.89
5100.0	24.45	23.95	25.05	10.27	10.31	10.80

RF (IN) (MHz)	LO (MHz)	RF-IF ISOLATION (dB)		
		@LO (dBm)		
		+1	+4	+7
1500.0	1530.0	21.47	23.25	23.82
1600.0	1630.0	22.55	23.29	23.53
1700.0	1730.0	23.63	23.51	23.13
1800.0	1830.0	24.74	23.80	22.95
1900.0	1930.0	25.13	24.13	23.75
2000.0	2030.0	24.96	24.59	24.48
2100.0	2130.0	26.20	25.91	26.50
2200.0	2230.0	31.93	30.97	31.71
2300.0	2330.0	34.47	34.70	34.29
2400.0	2430.0	24.60	25.28	25.58
2480.0	2510.0	20.94	21.52	21.92
2580.0	2610.0	18.74	19.29	19.65
2660.0	2690.0	18.00	18.51	18.83
2760.0	2790.0	17.81	18.30	18.62
2840.0	2870.0	17.71	18.13	18.36
2940.0	2970.0	17.72	17.92	18.04
3020.0	3050.0	17.85	17.89	17.77
3120.0	3150.0	17.81	17.63	17.43
3200.0	3230.0	17.48	17.11	16.75
3300.0	3330.0	16.98	16.45	16.03
3380.0	3410.0	17.44	16.86	16.50
3480.0	3510.0	16.54	15.89	15.50
3560.0	3590.0	15.78	15.21	14.76
3660.0	3690.0	14.88	14.33	13.94
3740.0	3770.0	14.18	13.77	13.40
3840.0	3870.0	13.31	12.93	12.66
3920.0	3950.0	12.76	12.42	12.25
4020.0	4050.0	12.00	11.82	11.73
4100.0	4130.0	11.53	11.40	11.38
4200.0	4230.0	10.88	10.57	10.41
4280.0	4310.0	10.35	9.96	9.70
4380.0	4410.0	10.08	9.81	9.67
4460.0	4490.0	10.18	10.03	9.92
4560.0	4590.0	10.55	10.51	10.55
4640.0	4670.0	10.97	11.14	11.10
4740.0	4770.0	12.13	12.42	12.23
4820.0	4850.0	13.54	13.64	12.91
4920.0	4950.0	15.97	15.29	13.19
5000.0	5030.0	16.94	15.12	12.23
5100.0	5130.0	13.99	12.58	10.38



Frequency Mixer

MBR-EE7756/4

Typical Performance Data

RF (IN) (MHz)	LO (MHz)	RF VSWR (:1)			LO (MHz)	LO VSWR (:1)			IF (OUT) (MHz)	IF VSWR @LO=4000MHz (:1)		
		@LO (dBm)				@LO (dBm)				@LO (dBm)		
		+1	+4	+7		+1	+4	+7		+1	+4	+7
1500.0	1530.0	11.53	9.79	8.68	1500.0	5.39	3.69	3.55	10.0	1.25	1.06	1.08
1600.0	1630.0	8.99	7.56	6.44	1600.0	3.38	2.73	2.98	30.2	1.26	1.07	1.09
1700.0	1730.0	7.02	5.97	5.04	1700.0	2.37	2.19	2.59	50.4	1.26	1.07	1.10
1800.0	1830.0	5.61	4.87	4.16	1800.0	1.80	1.84	2.29	70.6	1.29	1.11	1.10
1900.0	1930.0	4.46	3.92	3.50	1900.0	1.49	1.61	2.07	90.8	1.30	1.12	1.12
2000.0	2030.0	3.54	3.22	3.02	2000.0	1.34	1.41	1.85	111.0	1.33	1.15	1.13
2100.0	2130.0	2.94	2.78	2.69	2100.0	1.32	1.21	1.69	131.2	1.35	1.18	1.15
2200.0	2230.0	2.53	2.49	2.51	2200.0	1.42	1.11	1.58	151.4	1.37	1.19	1.15
2300.0	2330.0	2.19	2.24	2.34	2300.0	1.56	1.13	1.49	171.6	1.41	1.24	1.19
2400.0	2430.0	2.02	2.18	2.35	2400.0	1.68	1.18	1.42	191.8	1.45	1.26	1.20
2480.0	2510.0	1.86	2.04	2.21	2480.0	1.79	1.21	1.38	212.0	1.50	1.31	1.24
2580.0	2610.0	1.63	1.77	1.90	2580.0	1.85	1.22	1.33	232.2	1.51	1.33	1.25
2660.0	2690.0	1.32	1.44	1.55	2660.0	1.89	1.21	1.30	252.4	1.58	1.37	1.28
2760.0	2790.0	1.08	1.27	1.41	2760.0	1.88	1.19	1.27	272.7	1.63	1.42	1.32
2840.0	2870.0	1.15	1.30	1.46	2840.0	1.83	1.15	1.28	292.9	1.69	1.48	1.37
2940.0	2970.0	1.39	1.44	1.54	2940.0	1.78	1.10	1.35	313.1	1.73	1.51	1.40
3020.0	3050.0	1.55	1.59	1.66	3020.0	1.67	1.08	1.43	333.3	1.77	1.55	1.42
3120.0	3150.0	1.73	1.75	1.80	3120.0	1.54	1.14	1.57	353.5	1.86	1.62	1.48
3200.0	3230.0	1.82	1.85	1.91	3200.0	1.44	1.24	1.69	373.7	1.94	1.69	1.54
3300.0	3330.0	1.64	1.62	1.65	3300.0	1.34	1.32	1.84	393.9	2.02	1.77	1.61
3380.0	3410.0	2.04	1.90	1.81	3380.0	1.17	1.39	1.96	434.3	2.12	1.86	1.69
3480.0	3510.0	2.33	2.22	2.15	3480.0	1.06	1.54	2.17	454.5	2.25	1.97	1.79
3560.0	3590.0	2.36	2.27	2.21	3560.0	1.16	1.69	2.34	494.9	2.44	2.15	1.95
3660.0	3690.0	2.39	2.29	2.22	3660.0	1.36	1.89	2.57	515.1	2.45	2.17	1.97
3740.0	3770.0	2.40	2.30	2.23	3740.0	1.56	2.11	2.83	555.5	2.73	2.42	2.19
3840.0	3870.0	2.35	2.24	2.18	3840.0	1.84	2.36	3.08	575.7	2.87	2.56	2.32
3920.0	3950.0	2.28	2.17	2.11	3920.0	2.10	2.61	3.34	616.1	3.07	2.73	2.47
4020.0	4050.0	2.19	2.07	2.00	4020.0	2.50	2.92	3.62	636.3	3.11	2.78	2.54
4100.0	4130.0	2.14	1.99	1.91	4100.0	2.86	3.20	3.86	676.7	3.37	3.04	2.78
4200.0	4230.0	2.08	1.93	1.84	4200.0	3.35	3.56	4.15	696.9	3.42	3.07	2.81
4280.0	4310.0	2.04	1.91	1.86	4280.0	3.85	3.83	4.35	737.3	3.74	3.38	3.10
4380.0	4410.0	2.08	1.95	1.91	4380.0	4.72	4.35	4.67	757.6	3.79	3.45	3.19
4460.0	4490.0	2.11	1.98	1.97	4460.0	5.49	4.75	4.86	798.0	3.85	3.52	3.26
4560.0	4590.0	2.33	2.17	2.16	4560.0	6.42	5.33	5.13	818.2	4.09	3.74	3.46
4640.0	4670.0	2.54	2.35	2.33	4640.0	7.22	5.77	5.31	858.6	4.37	4.01	3.73
4740.0	4770.0	2.99	2.71	2.66	4740.0	8.08	6.30	5.58	878.8	4.23	3.91	3.67
4820.0	4850.0	3.55	3.11	2.99	4820.0	8.72	6.71	5.85	919.2	4.38	4.08	3.84
4920.0	4950.0	4.38	3.72	3.44	4920.0	8.99	6.83	5.87	939.4	4.73	4.39	4.09
5000.0	5030.0	4.92	4.09	3.69	5000.0	9.28	6.97	5.74	979.8	4.83	4.48	4.22
5100.0	5130.0	5.61	4.48	4.00	5100.0	8.90	7.08	5.66	1000.0	4.68	4.40	4.17

Harmonics Tables

RF HARMONICS ORDER

	(-dBm)	(dBc)										
0	-	-	+9	11	11	40	28	61	29	---	---	---
1	-	12	+0	29	18	40	44	37	55	53	---	---
2	>90	50	50	45	53	65	52	57	56	59	54	---
3	>90	66	63	>69	64	64	>69	>69	>69	>69	>69	>69
4	>90	>69	>69	>69	>69	>69	>69	>69	>69	>69	>69	>69
5	>90	>69	>69	>69	>69	>69	>69	>69	>69	>69	>69	>69
6	>90	>69	>69	>69	>69	>69	>69	>69	>69	>69	>69	>69
7	>90	>69	>69	>69	>69	>69	>69	>69	>69	>69	>69	>69
8	---	---	>69	>69	>69	>69	>69	>69	>69	>69	>69	>69
9	---	---	>69	>69	>69	>69	>69	>69	>69	>69	>69	>69
10	---	---	---	>69	>69	>69	>69	>69	>69	>69	>69	>69
	RF CAL	0	1	2	3	4	5	6	7	8	9	10

LO HARMONICS ORDER

Test conditions: RF IN: 3000 MHz; -15.00 dBm.
 LO IN: 3030 MHz; +4.00 dBm
 IF OUT: 30 MHz; -21.16 dBm

RF HARMONICS ORDER

	(-dBm)	(dBc)										
0	-	-	+0	22	22	57	42	52	45	---	---	---
1	-	12	+0	33	19	46	45	43	65	59	---	---
2	75	40	41	39	45	74	46	55	53	61	54	---
3	>90	47	43	50	44	46	47	56	68	59	66	73
4	>90	69	69	70	61	55	65	66	63	64	65	65
5	>90	75	76	75	>79	78	60	65	>79	71	77	70
6	90	>79	>79	>79	>79	>79	>79	72	>79	77	>79	75
7	>90	>79	>79	>79	>79	>79	>79	>79	76	>79	>79	>79
8	---	---	>79	>79	>79	>79	>79	>79	>79	>79	>79	>79
9	---	---	>79	>79	>79	>79	>79	>79	>79	>79	>79	>79
10	---	---	---	>79	>79	>79	>79	>79	>79	>79	>79	>79
	RF CAL	0	1	2	3	4	5	6	7	8	9	10

LO HARMONICS ORDER

Test conditions: RF IN: 3000 MHz; -5.00 dBm.
 LO IN: 3030 MHz; +4.00 dBm
 IF OUT: 30 MHz; -11.25 dBm

- Notes: 1. All Harmonics are in (dBc) relative to IF OUTPUT.
 2. + entry denotes harmonics are in (dBc) above IF OUTPUT.
 3. RF Cal represent the Harmonics level of the RF input signal to the mixer.

Typical Performance Curves

Conversion Loss @ IF=30MHz

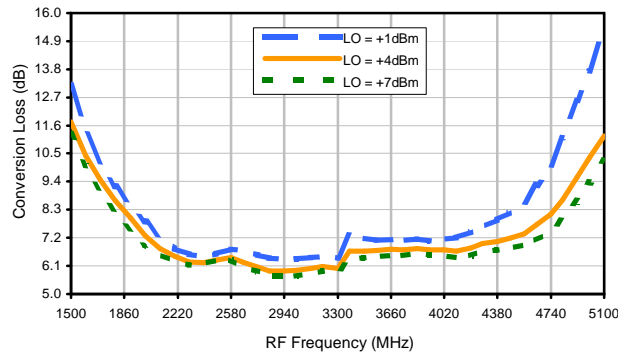

Conversion Loss vs. LO @ RF=3000MHz

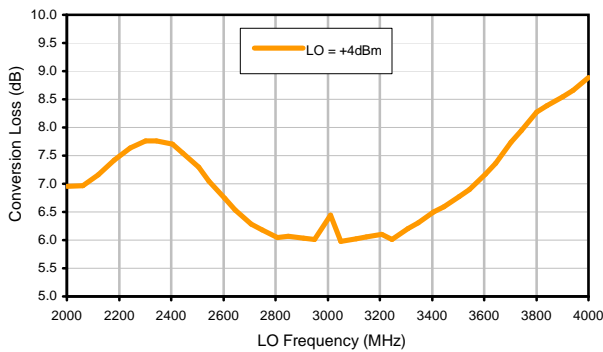

Conversion Loss vs. IF @ RF=3000MHz

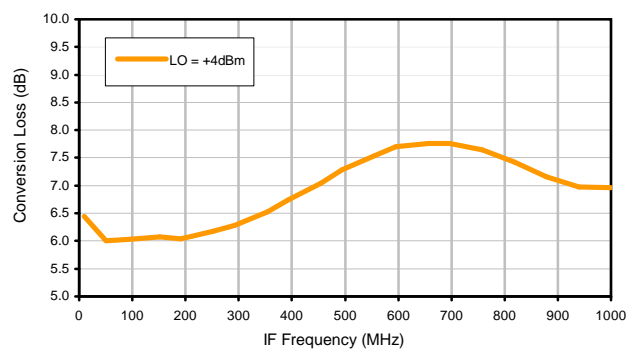

Conversion Loss vs. IF @ RF=1989.9MHz

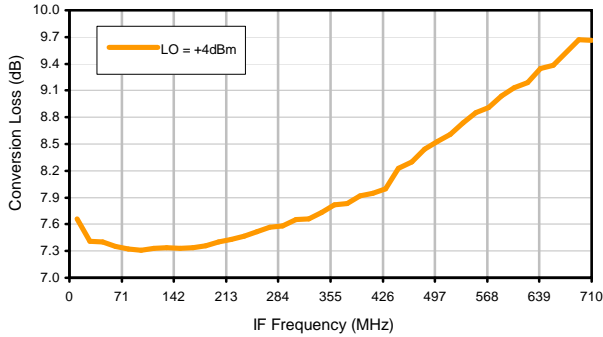

Conversion Loss vs. IF @ RF=4010MHz

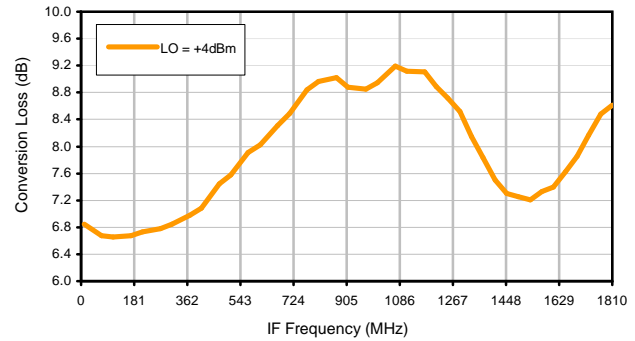

IP3 Input

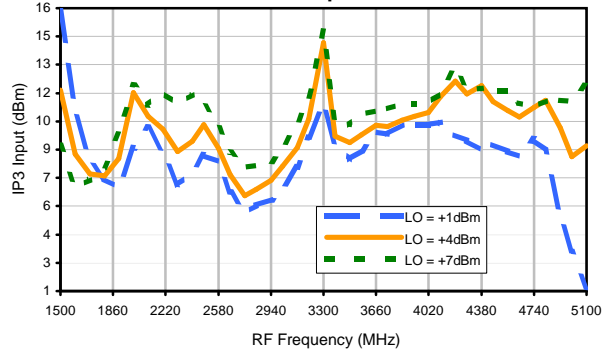

Compression @ RF IN=0dBm

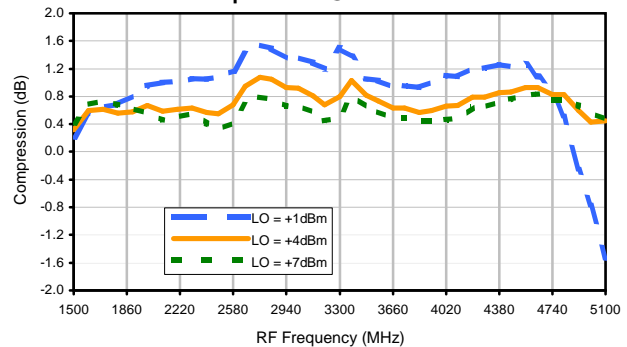

Typical Performance Curves

LO-RF Isolation

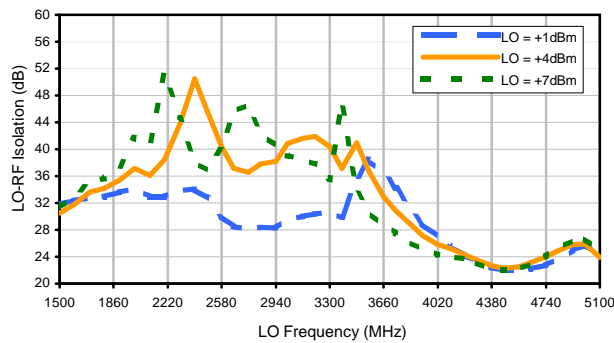

LO-IF Isolation

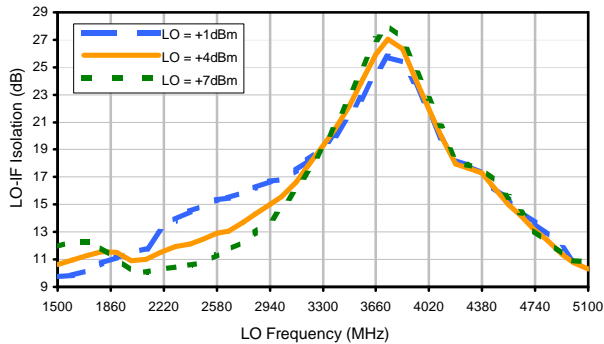

RF-IF Isolation

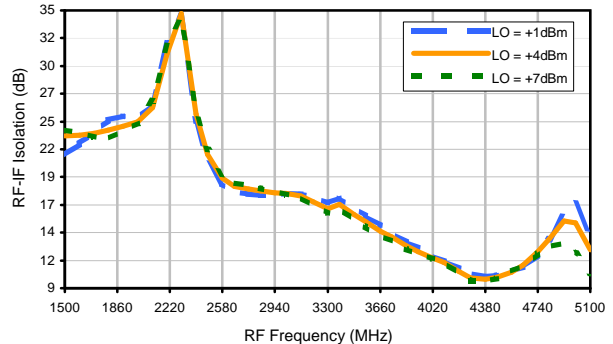

RF VSWR

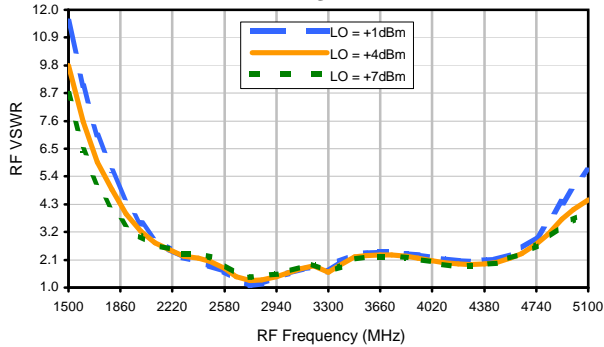

LO VSWR

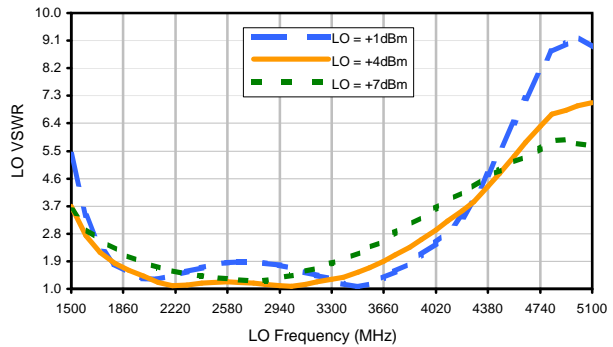

IF VSWR

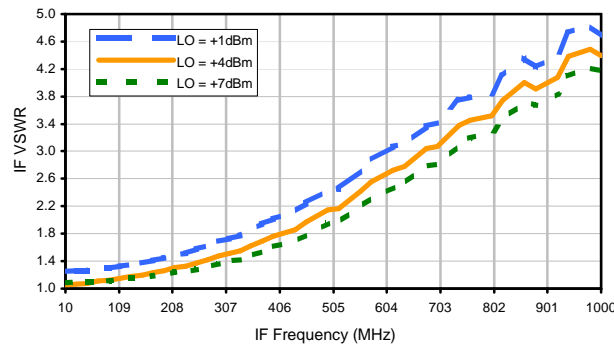

Harmonics Tables

RF HARMONICS ORDER

	(-dBm)	(dBc)										
0	-	-	+9	11	11	40	28	61	29	---	---	---
1	-	12	+0	29	18	40	44	37	55	53	---	---
2	>90	50	50	45	53	65	52	57	56	59	54	---
3	>90	66	63	>69	64	64	>69	>69	>69	>69	>69	>69
4	>90	>69	>69	>69	>69	>69	>69	>69	>69	>69	>69	>69
5	>90	>69	>69	>69	>69	>69	>69	>69	>69	>69	>69	>69
6	>90	>69	>69	>69	>69	>69	>69	>69	>69	>69	>69	>69
7	>90	>69	>69	>69	>69	>69	>69	>69	>69	>69	>69	>69
8	---	---	>69	>69	>69	>69	>69	>69	>69	>69	>69	>69
9	---	---	>69	>69	>69	>69	>69	>69	>69	>69	>69	>69
10	---	---	---	>69	>69	>69	>69	>69	>69	>69	>69	>69
	RF CAL	0	1	2	3	4	5	6	7	8	9	10

LO HARMONICS ORDER

Test conditions: RF IN: 3000 MHz; -15.00 dBm.
 LO IN: 3030 MHz; +4.00 dBm
 IF OUT: 30 MHz; -21.16 dBm

RF HARMONICS ORDER

	(-dBm)	(dBc)										
0	-	-	+0	22	22	57	42	52	45	---	---	---
1	-	12	+0	33	19	46	45	43	65	59	---	---
2	75	40	41	39	45	74	46	55	53	61	54	---
3	>90	47	43	50	44	46	47	56	68	59	66	73
4	>90	69	69	70	61	55	65	66	63	64	65	65
5	>90	75	76	75	>79	78	60	65	>79	71	77	70
6	90	>79	>79	>79	>79	>79	>79	72	>79	77	>79	75
7	>90	>79	>79	>79	>79	>79	>79	>79	76	>79	>79	>79
8	---	---	>79	>79	>79	>79	>79	>79	>79	>79	>79	>79
9	---	---	>79	>79	>79	>79	>79	>79	>79	>79	>79	>79
10	---	---	---	>79	>79	>79	>79	>79	>79	>79	>79	>79
	RF CAL	0	1	2	3	4	5	6	7	8	9	10

LO HARMONICS ORDER

Test conditions: RF IN: 3000 MHz; -5.00 dBm.
 LO IN: 3030 MHz; +4.00 dBm
 IF OUT: 30 MHz; -11.25 dBm

- Notes: 1. All Harmonics are in (dBc) relative to IF OUTPUT.
 2. + entry denotes harmonics are in (dBc) above IF OUTPUT.
 3. RF Cal represent the Harmonics level of the RF input signal to the mixer.

Outline Dimensions

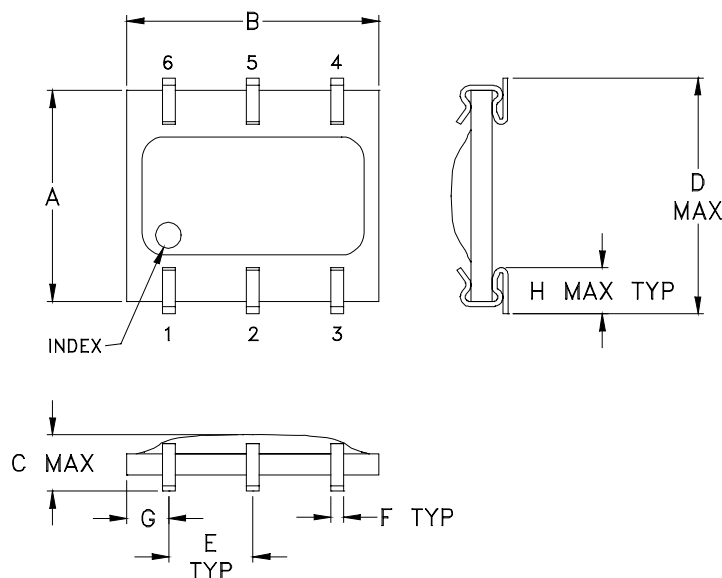

PCB Land Pattern

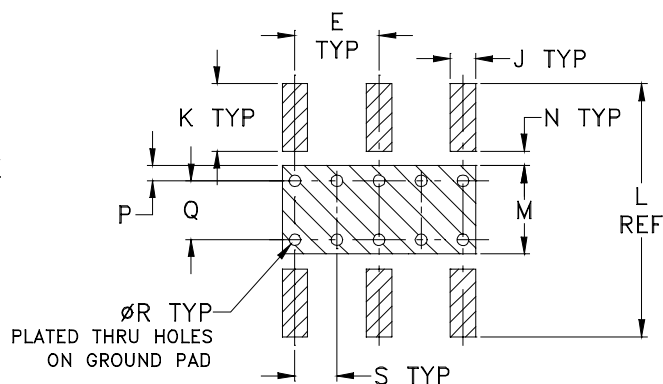

Suggested Layout,

Tolerance to be within $\pm .002$
 ADJACENT GROUND PINS SHALL BE CONNECTED
 TO EACH OTHER AND TO GROUND PAD

CASE#	A	B	C	D	E	F	G	H	J	K	L	M	N
SM26	.250 (6.35)	.300 (7.62)	.095 (2.41)	.290 (7.37)	.100 (2.54)	.015 (.38)	.050 (1.27)	.060 (1.52)	.030 (.76)	.080 (2.03)	.300 (7.62)	.100 (2.54)	.020 (.51)

CASE#	P	Q	R	S	WT, GRAM
SM26	.015 (.38)	.070 (1.78)	.014 (.36)	.050 (1.27)	.3

Dimensions are in inches (mm). Tolerances: 2 Pl. $\pm .005$; 3 Pl. $\pm .005$

Notes:

- Case material: Plastic encapsulation on Ceramic base.
- Termination finish:
 For RoHS Case Styles: Tin plate over Nickel plate.
 For RoHS-5 Case Styles: Tin-Lead plate.

Tape & Reel Packaging TR-F34



Tape Width, mm	Device Cavity Pitch, mm	Reel Size, inches	Devices per Reel see note	
16	12	7	Small quantity standard (see note)	20
				50
				100
				200
		13	Standard	500
				1000

Note: Availability of small reel quantity varies by model.
Refer to pricing and availability on individual model dashboard.

Mini-Circuits carrier tape materials provide protection from ESD (Electro-Static Discharge) during handling and transportation. Tapes are static dissipative and comply with industry standards EIA-481/EIA-541.

Go to: www.minicircuits.com/pages/pdfs/tape.pdf



INTERNET <http://www.minicircuits.com>

P.O. Box 350166, Brooklyn, New York 11235-0003 (718) 934-4500 Fax (718) 332-4661

Distribution Centers NORTH AMERICA 800-654-7949 • 417-335-5935 • Fax 417-335-5945 • EUROPE 44-1252-832600 • Fax 44-1252-837010

Mini-Circuits ISO 9001 & ISO 14001 Certified

All Mini-Circuits products are manufactured under exacting quality assurance and control standards, and are capable of meeting published specifications after being subjected to any or all of the following physical and environmental test.

Specification	Test/Inspection Condition	Reference/Spec
Operating Temperature	-40° to 85°C Ambient Environment	Individual Model Data Sheet
Storage Temperature	-55° to 100° C Ambient Environment	Individual Model Data Sheet
Humidity	90 to 95% RH, 240 hours, 50°C	MIL-STD-202, Method 103, Condition A, Except 50°C and end-point electrical test done within 12 hours
Thermal Shock	-55° to 100°C, 100 cycles	MIL-STD-202, Method 107, Condition A-3, except +100°C
Solder Reflow Heat	Sn-Pb Eutetic Process: 225°C peak Pb-Free Process 245° - 250°C peak	J-STD-020, Table 4-1, 4-2 and 5-2, Figure 5-1
Solderability	10X Magnification	J-STD-002, 95% Coverage
Vibration (High Frequency)	20g peak, 10-2000 Hz, 12 times in each of three perpendicular directions (total 36)	MIL-STD-202, Method 204, Condition D
Mechanical Shock	50g, 11 ms, 1/2-sine, 18 shocks: 3 each direction, each of 3 axes	MIL-STD-202, Method 213, Condition A
Marking Resistance to Solvents	Isopropyl alcohol + mineral spirits at 25°C; terpene defluxer at 25°C; distilled water + proylene glycol monomethyl ether + monoethanolamine at 63°C to 70°C	MIL-STD-202, Method 215