



USB & ETHERNET CONTROLLED

RF Switch Matrix

RC-2SP6T-A18



50Ω DC to 18 GHz SMA-Female

THE BIG DEAL

- Dual mechanical SP6T switch box
- High reliability, millions of cycles
- 20W power rating (cold switching)
- High isolation, 90 dB typ

APPLICATIONS

- R&D
- Automated Test equipment
- Controlling RF signal paths

PRODUCT OVERVIEW

Mini-Circuits' RC-2SP6T-A18 comprises a pair of independently controlled, electro-mechanical SP6T switches. Each switch operates over an extremely wide bandwidth, from DC to 18 GHz with high isolation and low insertion loss. The absorptive switches are of a failsafe and break-before-make-configuration, with a lifetime of 5 million cycles, when used within the noted specifications.

The switch box is constructed in a compact, rugged metal case (5.5 x 6.0 x 2.75") with 14 SMA (f) RF connectors on the front panel. The switches are controlled via USB or Ethernet, allowing control directly from a PC, or remotely over a network. Full software support is provided, including our user-friendly GUI application for Windows and a full API with programming instructions for Windows and Linux environments (both 32-bit and 64-bit systems).

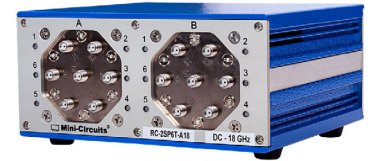

CASE STYLE: PF2018

[DOWNLOAD](#) SOFTWARE PACKAGE

RoHS Compliant

See our website for RoHS Compliance methodologies and qualifications

KEY FEATURES

Feature	Advantages
Dual mechanical SP6T switches	Mechanical absorptive switches provide high reliability, repeatable high performance and internal terminations of input signals on the disconnected paths
Operation from DC to 18 GHz	Supports a wide range of RF test and signal routing applications, including 2G, 3G, 4G and 5G, with a single device
Break-before-make configuration	Prevents a momentary connection of the old and new signal paths, reducing the inconsistent transient effects that could otherwise be observed during switching
USB & Ethernet control	USB HID and Ethernet (HTTP / Telnet) interfaces provide easy compatibility with a wide range of software setups and programming environments
Full software support	User friendly Windows GUI (graphical user interface) allows manual control straight out of the box, while the comprehensive API (application programming interface) with examples and instructions allows easy automation in most programming environments

Windows is a registered trademarks of Microsoft Corporation in the United States and other countries. Linux is a registered trademark of Linus Torvalds. Mac is a registered trademark of Apple Corporation in the United States and other countries. Neither Mini-Circuits nor the Mini-Circuits RC-2SP6T-A18 are affiliated with or endorsed by the owners of the above referenced trademarks. Mini-Circuits and the Mini-Circuits logo are registered trademarks of Scientific Components Corporation.

REV. C
ECO-027309
RC-2SP6T-A18
MCL NY
251010





USB & ETHERNET CONTROLLED

RF Switch Matrix

RC-2SP6T-A18

Mini-Circuits

50Ω DC to 18 GHz SMA-Female

ELECTRICAL SPECIFICATIONS

Parameter	Conditions (GHz)	Min.	Typ.	Max.	Units
Frequency	-	DC	-	18	GHz
Insertion Loss	DC-8 GHz	-	0.10	0.25	dB
	8-12 GHz	-	0.20	0.40	
	12-18 GHz	-	0.40	0.80	
Isolation (Inactive Paths) ¹	DC-8 GHz	75	80	-	dB
	8-12 GHz	65	70	-	
	12-18 GHz	65	70	-	
Return Loss ²	DC-8 GHz	-	23	-	dB
	8-12 GHz	-	20	-	
	12-18 GHz	-	15	-	
Switching Time		-	25	-	ms
RF Input Power	Cold switching	-	-	20	W
	Hot switching ³	-	-	0.1	
	Into internal termination ⁴	-	-	1	
Switch Lifetime	-	-	5	-	million switching cycles

1. Isolation measured between Com and any disconnected port. Example: Isolation for Com to 1 is the leakage measured at port 1 from a signal input at Com when the active switch path is set to Com to 2

2. Return loss into Com when active or ports 1-6 in any state; Com is reflective when disconnected

3. Hot switching power above this level will degrade the switch lifetime

4. Maximum power into any internal termination is 1W per port, 3W total per switch

ABSOLUTE MAXIMUM RATINGS

Parameter	Ratings
Operating Temperature	0°C to 40°C
Storage Temperature	-15°C to 85°C
DC Voltage max.	26V
RF power (through path)	20W
RF power (into internal termination) ³	1W

3. 1W per termination, 3W total

Permanent damage may occur if any of these limits are exceeded.





USB & ETHERNET CONTROLLED

RF Switch Matrix

RC-2SP6T-A18

Mini-Circuits

50Ω DC to 18 GHz SMA-Female

SWITCHING CONFIGURATION:

- Normally open (all port disconnected)
- Absorptive (internal terminations on ports J1-J6)

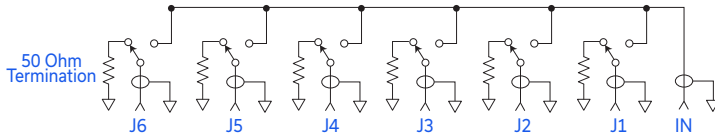

CONNECTIONS

24V _{DC} IN	2.1 mm center positive DC Socket
RF Switch A (All ports)	SMA female
RF Switch B (All ports)	SMA female
USB	USB type B receptacle
Network (Ethernet/LAN)	RJ45 socket

OUTLINE DRAWING (PF2018)

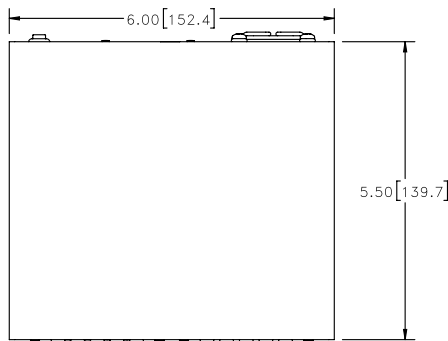

TOP VIEW

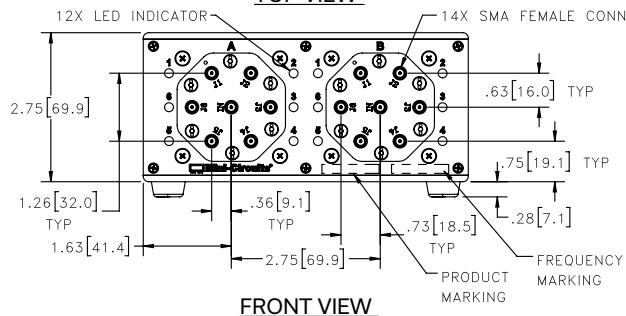

FRONT VIEW

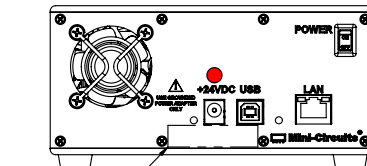

REAR VIEW

BRACKET OPTION

ONE SET OF 2 EACH

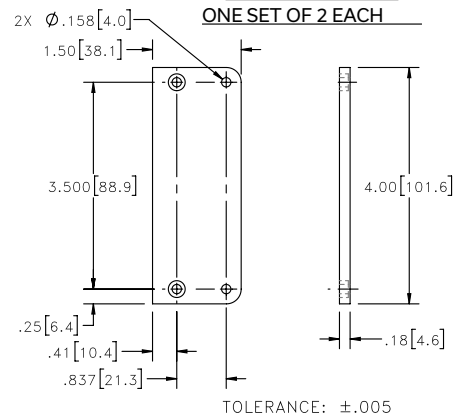

INSTRUCTIONS FOR MOUNTING BRACKETS:

- TOOL REQUIRED: PHILLIPS HEAD SCREWDRIVER
- STEP 1: REMOVE RUBBER FEET FROM THE BOTTOM OF THE UNIT. DO NOT DISCARD THE FASTENERS.
- STEP 2: MOUNT THE BRACKETS WITH THE FASTENERS REMOVED IN STEP 1, USING THE COUNTER BORE HOLES IN THE BRACKET.

Weight: 1350 grams.

Dimensions are in inches [mm]. Tolerances: 2 Pl. ± .03 inch; 3 Pl. ± .015 inch.

Mini-Circuits



USB & ETHERNET CONTROLLED

RF Switch Matrix

RC-2SP6T-A18

Mini-Circuits

50Ω DC to 18 GHz SMA-Female

TYPICAL PERFORMANCE DATA

FREQ. (MHz)	ON INSERTION LOSS (dB)						ISOLATION (dB)	VSWR (:1)						
	IN-J1	IN-J2	IN-J3	IN-J4	IN-J5	IN-J6		IN	J1-ON	J2-ON	J3-ON	J4-ON	J5-ON	J6-ON
500	0.02	0.01	0.01	0.01	0.01	0.01	102.06	1.03	1.01	1.01	1.01	1.01	1.01	1.02
1000	0.02	0.02	0.02	0.02	0.02	0.02	105.92	1.00	1.00	1.00	1.01	1.02	1.02	1.03
2050	0.04	0.04	0.03	0.04	0.03	0.04	109.70	1.03	1.01	1.03	1.03	1.04	1.04	1.04
3100	0.05	0.05	0.05	0.05	0.04	0.04	107.38	1.05	1.04	1.04	1.03	1.02	1.01	1.03
4150	0.06	0.06	0.05	0.06	0.05	0.05	111.45	1.06	1.07	1.06	1.06	1.06	1.06	1.07
5200	0.07	0.07	0.07	0.07	0.06	0.07	112.55	1.07	1.06	1.05	1.06	1.06	1.05	1.07
6250	0.08	0.08	0.07	0.08	0.07	0.08	108.43	1.01	1.01	1.02	1.03	1.02	1.04	1.07
7300	0.10	0.09	0.09	0.10	0.09	0.10	106.13	1.04	1.05	1.02	1.05	1.06	1.06	1.10
8000	0.11	0.10	0.10	0.11	0.10	0.11	105.22	1.08	1.08	1.04	1.07	1.10	1.08	1.13
9000	0.13	0.12	0.11	0.13	0.11	0.12	109.97	1.12	1.11	1.06	1.09	1.12	1.09	1.14
10000	0.14	0.13	0.12	0.13	0.12	0.13	108.68	1.11	1.10	1.07	1.09	1.12	1.10	1.12
12000	0.14	0.15	0.13	0.14	0.14	0.14	105.00	1.07	1.07	1.10	1.10	1.10	1.09	1.09
14000	0.19	0.20	0.18	0.18	0.17	0.18	101.80	1.08	1.08	1.15	1.10	1.09	1.06	1.05
16000	0.37	0.33	0.36	0.35	0.30	0.30	103.98	1.33	1.33	1.35	1.32	1.35	1.26	1.26
18000	0.47	0.40	0.44	0.43	0.36	0.43	97.06	1.46	1.50	1.44	1.45	1.46	1.42	1.54

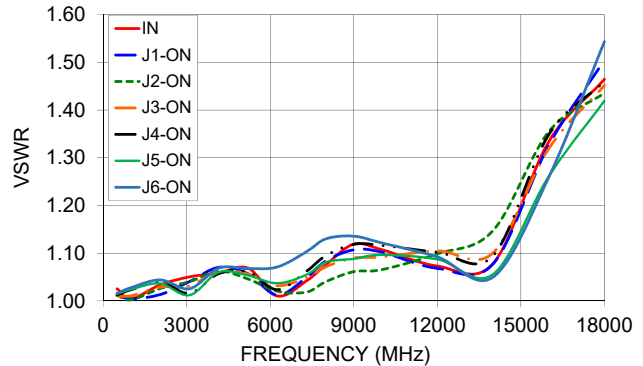
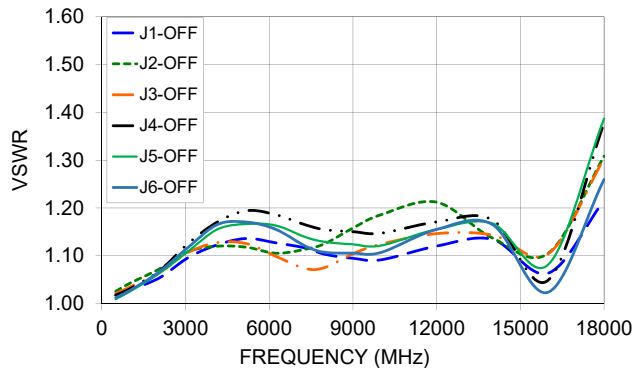
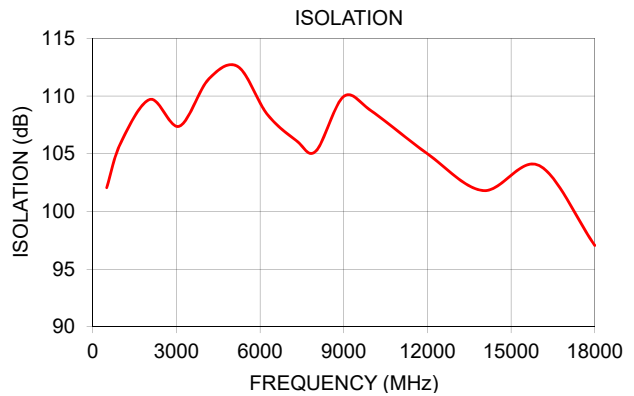
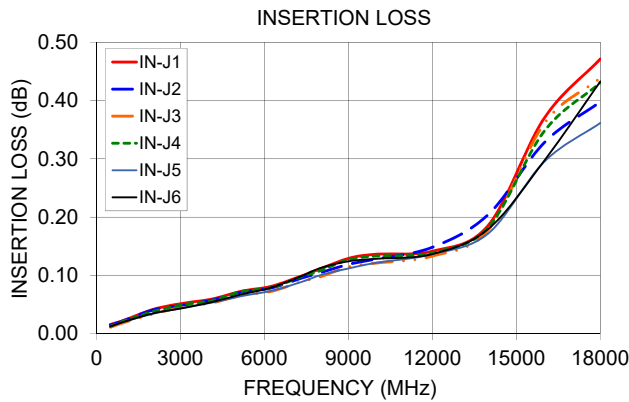



SOFTWARE SPECIFICATIONS

SOFTWARE & DOCUMENTATION DOWNLOAD:

- Mini-Circuits' full software and support package including user guide, Windows GUI, DLL files, programming manual and examples can be downloaded free of charge from: <https://www.minicircuits.com/softwaredownload/rfswitchcontroller.html>
- Please contact testsolutions@minicircuits.com for support

MINIMUM SYSTEM REQUIREMENTS:

Parameter	Requirements	
Interface	USB HID & Ethernet (HTTP & Telnet)	
System Requirements	GUI	Windows 98 or later
	USB API DLL	Windows 98 or later and programming environment with ActiveX or .NET support
	USB Direct Programming	Linux, Windows 98 or later
	Ethernet	Windows, Linux or Mac computer with a network port and Ethernet TCP/IP support
Hardware	Pentium II or later with 256 MB RAM	

APPLICATION PROGRAMMING INTERFACE (API)

ETHERNET SUPPORT:

- Simple ASCII / SCPI command set for attenuator control
- Communication via HTTP or Telnet
- Supported by most common programming environments

USB SUPPORT (WINDOWS):

- ActiveX COM DLL file for creation of 32-bit programs
- .NET library DLL file for creation of 32 / 64-bit programs
- Supported by most common programming environments (refer to application note AN-49-001 for summary of supported environments)

USB SUPPORT (LINUX):

- Direct USB programming using a series of USB interrupt codes

Full programming instructions and examples available for a wide range of programming environments / languages.



GRAPHICAL USER INTERFACE (GUI) FOR WINDOWS - KEY FEATURES

- Connect via USB or Ethernet
- Run GUI in "demo mode" to evaluate software without a hardware connection

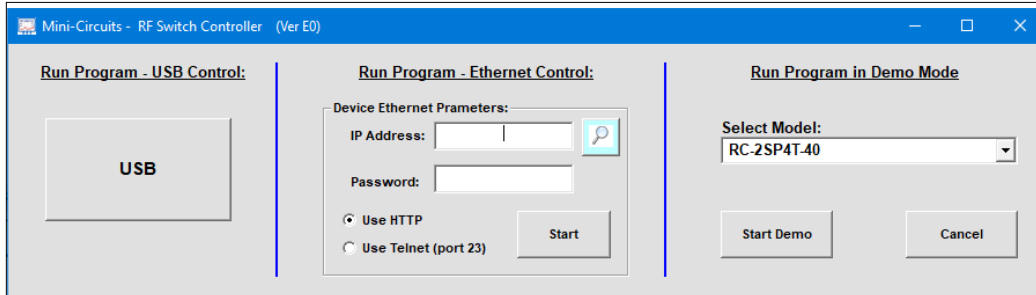

- View and set switch states at the click of a button
- Configure and run timed switching sequences
- Set start-up switch state
- Configure Ethernet IP settings

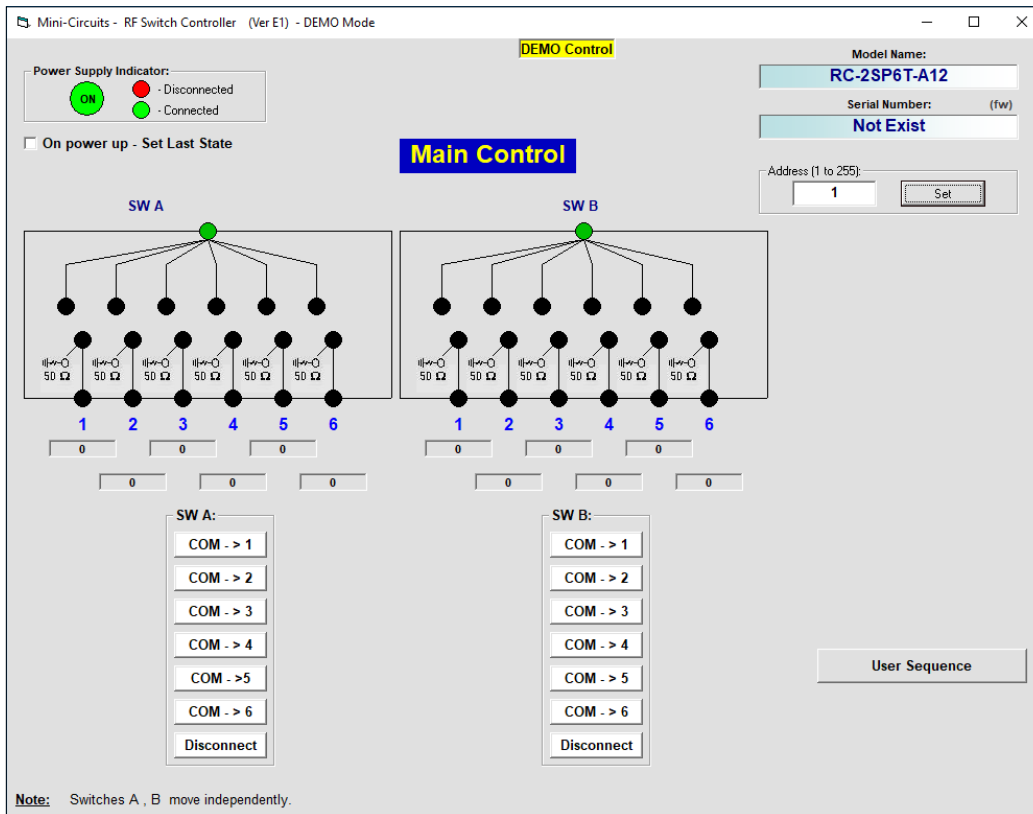



USB & ETHERNET CONTROLLED

RF Switch Matrix

RC-2SP6T-A18



Mini-Circuits





50Ω DC to 18 GHz SMA-Female

ORDERING INFORMATION

Please contact Mini-Circuits' Test Solutions department for price and availability: testsolutions@minicircuits.com

Model	Description
RC-2SP6T-A18	USB & Ethernet controlled SP6T switch matrix

Included Accessories	Part No.	Description
	AC/DC-24-3W1	AC/DC 24V _{DC} Grounded Power Adaptor. Operating temperature: 0°C to +40°C, I _{Max} =2.5A
See Below	CBL-3W1-XX	AC Power Cord (Select one power cord from below with each Switch Matrix box)
	USB-CBL-AB-3+	2.7 ft (0.8 m) USB Cable: USB type A(Male) to USB type B(Male)
	CBL-RJ45-MM-5+	5 ft (1.5 m) Ethernet cable: RJ45(Male) to RJ45(Male) Cat 5E cable

AC Power Cords ⁴	Part No.	Description
	CBL-3W1-US	Power Cord for United States
	CBL-3W1-EU	Power Cord for Europe
	CBL-3W1-UK	Power Cord for United Kingdom
	CBL-3W1-AU	Power Cord for Australia and China
	CBL-3W1-IL	Power Cord for Israel

4. If you need a Power cord for a country not listed please contact testsolutions@minicircuits.com

OPTIONAL ACCESSORIES

USB-CBL-AB-3+	2.7 ft (0.8 m) USB Cable: USB type A(Male) to USB type B (Male)
USB-CBL-AB-7+	6.8 ft (2.1 m) USB Cable: USB type A(Male) to USB type B (Male)
USB-CBL-AB-11+	11 ft (3.4 m) USB Cable: USB type A(Male) to USB type B (Male)
CBL-RJ45-MM-5+	5 ft (1.5 m) Ethernet cable: RJ45(Male) to RJ45 (Male) Cat 5E cable
BKT-272-08+	Bracket (One set of 2 each)

- NOTES**
- A. Performance and quality attributes and conditions not expressly stated in this specification document are intended to be excluded and do not form a part of this specification document.
 - B. Electrical specifications and performance data contained in this specification document are based on Mini-Circuit's applicable established test performance criteria and measurement instructions.
 - C. The parts covered by this specification document are subject to Mini-Circuits standard limited warranty and terms and conditions (collectively, "Standard Terms"); Purchasers of this part are entitled to the rights and benefits contained therein. For a full statement of the standard. Terms and the exclusive rights and remedies thereunder, please visit Mini-Circuits' website at www.minicircuits.com/MCLStore/terms.jsp



Xtra Long Life

USB/ETHERNET RF SP6T SWITCH MATRIX

RC-2SP6T-A18

Typical Performance Data (per Switch)

FREQUENCY (MHz)	INSERTION LOSS (dB)						ISOLATION (dB)
	IN-J1	IN-J2	IN-J3	IN-J4	IN-J5	IN-J6	
500	0.02	0.01	0.01	0.01	0.01	0.01	102.06
600	0.02	0.02	0.01	0.01	0.01	0.01	101.51
700	0.02	0.02	0.01	0.02	0.01	0.01	107.20
800	0.02	0.02	0.02	0.02	0.02	0.02	105.83
900	0.02	0.02	0.02	0.02	0.02	0.02	104.44
1000	0.02	0.02	0.02	0.02	0.02	0.02	105.92
1400	0.02	0.02	0.02	0.03	0.03	0.03	108.96
1800	0.03	0.03	0.03	0.03	0.03	0.03	109.91
2200	0.04	0.04	0.04	0.04	0.04	0.04	109.13
2600	0.05	0.05	0.04	0.04	0.04	0.04	110.86
3000	0.05	0.05	0.04	0.05	0.04	0.04	108.60
3400	0.05	0.05	0.05	0.05	0.05	0.05	110.15
3800	0.05	0.05	0.05	0.05	0.05	0.05	111.93
4200	0.06	0.06	0.05	0.06	0.05	0.05	112.14
4600	0.07	0.07	0.06	0.07	0.06	0.06	110.23
5000	0.07	0.07	0.06	0.07	0.06	0.07	110.90
5400	0.07	0.07	0.07	0.07	0.07	0.07	108.60
5800	0.08	0.07	0.07	0.07	0.07	0.07	109.28
6200	0.08	0.08	0.07	0.08	0.07	0.08	108.36
6600	0.09	0.09	0.08	0.09	0.08	0.09	107.58
7000	0.09	0.09	0.08	0.09	0.08	0.09	105.64
7400	0.10	0.10	0.09	0.10	0.09	0.10	107.01
7800	0.11	0.10	0.10	0.11	0.10	0.11	103.59
8200	0.12	0.11	0.10	0.11	0.10	0.12	109.73
8600	0.12	0.12	0.11	0.12	0.11	0.12	108.94
9000	0.13	0.12	0.11	0.13	0.11	0.12	109.97
9400	0.13	0.12	0.12	0.13	0.11	0.13	107.97
9800	0.14	0.13	0.12	0.13	0.12	0.13	106.85
10200	0.14	0.13	0.12	0.13	0.12	0.13	104.67
10600	0.14	0.13	0.12	0.14	0.13	0.13	106.95
11000	0.14	0.14	0.13	0.14	0.13	0.13	107.57
11400	0.14	0.14	0.13	0.14	0.13	0.13	104.43
11800	0.14	0.14	0.13	0.14	0.13	0.13	106.02
12200	0.14	0.15	0.14	0.14	0.14	0.14	103.15
12600	0.15	0.16	0.14	0.15	0.14	0.15	101.46
13000	0.15	0.17	0.15	0.15	0.15	0.16	103.38
13400	0.16	0.18	0.16	0.16	0.16	0.16	102.49
13800	0.18	0.20	0.17	0.17	0.17	0.17	98.49
14200	0.20	0.21	0.19	0.19	0.18	0.19	99.03
14600	0.22	0.23	0.21	0.22	0.20	0.20	103.01
15000	0.26	0.25	0.25	0.25	0.22	0.23	104.16
15400	0.30	0.27	0.29	0.29	0.25	0.25	105.37
15800	0.35	0.30	0.34	0.33	0.28	0.28	106.79
16200	0.39	0.35	0.37	0.36	0.31	0.32	105.44
16600	0.42	0.37	0.39	0.38	0.35	0.37	105.43
17000	0.43	0.38	0.41	0.40	0.39	0.43	103.69
17400	0.45	0.39	0.42	0.41	0.38	0.44	105.17
17800	0.46	0.39	0.43	0.42	0.36	0.43	96.60
18000	0.47	0.40	0.44	0.43	0.36	0.43	97.06



P.O. Box 350166, Brooklyn, New York 11235-0003 (718) 934-4500 • Fax (718) 332-4661 For detailed performance specs & shopping online see Mini-Circuits web site
 The Design Engineers Search Engine Provides ACTUAL Data Instantly From MINI-CIRCUITS At: www.minicircuits.com



IF/RF MICROWAVE COMPONENTS

REV. OR
 RC-2SP6T-A18
 7/17/2020
 Page 1 of 2

Xtra Long Life

USB/ETHERNET RF SP6T SWITCH MATRIX

RC-2SP6T-A18

Typical Performance Data (per Switch)

FREQUENCY (MHz)	VSWR (:1)							VSWR (:1)					
	IN	J1-ON	J2-ON	J3-ON	J4-ON	J5-ON	J6-ON	J1-OFF	J2-OFF	J3-OFF	J4-OFF	J5-OFF	J6-OFF
500	1.03	1.01	1.01	1.01	1.01	1.01	1.02	1.02	1.03	1.02	1.02	1.01	1.01
600	1.02	1.01	1.01	1.01	1.02	1.02	1.02	1.02	1.03	1.02	1.02	1.01	1.01
700	1.01	1.01	1.01	1.01	1.02	1.02	1.02	1.02	1.03	1.03	1.02	1.01	1.02
800	1.01	1.01	1.01	1.01	1.02	1.02	1.02	1.02	1.03	1.03	1.02	1.02	1.02
900	1.01	1.01	1.00	1.01	1.02	1.02	1.03	1.03	1.04	1.03	1.03	1.02	1.02
1000	1.00	1.00	1.00	1.01	1.02	1.02	1.03	1.03	1.04	1.03	1.03	1.03	1.03
1400	1.01	1.01	1.01	1.02	1.03	1.03	1.03	1.03	1.05	1.04	1.04	1.04	1.04
1800	1.03	1.01	1.02	1.03	1.04	1.04	1.04	1.04	1.06	1.06	1.06	1.05	1.06
2200	1.04	1.01	1.03	1.03	1.04	1.03	1.04	1.06	1.08	1.07	1.07	1.07	1.07
2600	1.05	1.02	1.03	1.02	1.02	1.02	1.03	1.08	1.09	1.09	1.10	1.09	1.09
3000	1.05	1.04	1.04	1.03	1.01	1.01	1.02	1.09	1.11	1.10	1.12	1.10	1.11
3400	1.05	1.05	1.05	1.04	1.03	1.03	1.04	1.11	1.11	1.12	1.14	1.12	1.13
3800	1.05	1.07	1.06	1.06	1.05	1.05	1.06	1.12	1.12	1.12	1.16	1.14	1.15
4200	1.06	1.07	1.06	1.06	1.06	1.06	1.07	1.12	1.12	1.13	1.17	1.16	1.17
4600	1.07	1.06	1.05	1.06	1.06	1.06	1.07	1.13	1.12	1.13	1.18	1.16	1.17
5000	1.07	1.06	1.05	1.06	1.06	1.06	1.07	1.13	1.12	1.13	1.19	1.17	1.17
5400	1.06	1.05	1.04	1.05	1.06	1.05	1.07	1.14	1.12	1.12	1.19	1.17	1.17
5800	1.04	1.04	1.03	1.04	1.04	1.04	1.07	1.13	1.11	1.11	1.19	1.17	1.16
6200	1.01	1.02	1.02	1.03	1.03	1.04	1.07	1.13	1.11	1.10	1.19	1.16	1.16
6600	1.01	1.01	1.01	1.03	1.02	1.04	1.08	1.12	1.11	1.09	1.18	1.16	1.15
7000	1.03	1.03	1.01	1.04	1.04	1.04	1.09	1.12	1.11	1.08	1.17	1.15	1.13
7400	1.05	1.05	1.02	1.05	1.07	1.06	1.11	1.11	1.12	1.07	1.16	1.14	1.12
7800	1.07	1.08	1.04	1.07	1.09	1.08	1.12	1.11	1.12	1.07	1.16	1.13	1.11
8200	1.09	1.09	1.05	1.08	1.10	1.09	1.14	1.10	1.13	1.08	1.15	1.13	1.11
8600	1.11	1.10	1.05	1.09	1.11	1.09	1.14	1.10	1.14	1.09	1.15	1.13	1.11
9000	1.12	1.11	1.06	1.09	1.12	1.09	1.14	1.09	1.16	1.10	1.15	1.12	1.11
9400	1.12	1.11	1.06	1.09	1.12	1.09	1.13	1.09	1.17	1.12	1.15	1.12	1.10
9800	1.11	1.11	1.07	1.09	1.12	1.09	1.13	1.09	1.18	1.12	1.15	1.12	1.11
10200	1.11	1.10	1.07	1.09	1.12	1.10	1.11	1.09	1.19	1.13	1.14	1.12	1.11
10600	1.11	1.10	1.07	1.10	1.12	1.10	1.11	1.09	1.19	1.13	1.14	1.13	1.12
11000	1.11	1.09	1.08	1.11	1.12	1.09	1.09	1.09	1.20	1.13	1.14	1.13	1.13
11400	1.09	1.08	1.09	1.11	1.12	1.09	1.09	1.10	1.21	1.14	1.15	1.14	1.14
11800	1.08	1.07	1.09	1.11	1.11	1.09	1.09	1.11	1.21	1.14	1.16	1.15	1.15
12200	1.07	1.06	1.10	1.10	1.10	1.08	1.10	1.13	1.21	1.15	1.18	1.16	1.16
12600	1.06	1.06	1.11	1.10	1.09	1.08	1.10	1.14	1.20	1.16	1.19	1.17	1.17
13000	1.06	1.05	1.13	1.10	1.08	1.07	1.09	1.14	1.19	1.16	1.19	1.18	1.18
13400	1.05	1.06	1.13	1.10	1.09	1.06	1.08	1.14	1.17	1.15	1.19	1.18	1.18
13800	1.06	1.07	1.14	1.10	1.09	1.06	1.06	1.14	1.15	1.15	1.19	1.17	1.17
14200	1.09	1.09	1.15	1.11	1.10	1.06	1.04	1.13	1.13	1.14	1.16	1.16	1.16
14600	1.14	1.11	1.17	1.12	1.13	1.08	1.05	1.12	1.11	1.12	1.13	1.14	1.14
15000	1.19	1.15	1.21	1.16	1.17	1.11	1.08	1.10	1.09	1.10	1.09	1.11	1.11
15400	1.24	1.21	1.26	1.20	1.23	1.15	1.13	1.08	1.08	1.09	1.04	1.09	1.08
15800	1.30	1.28	1.32	1.28	1.31	1.22	1.21	1.07	1.09	1.10	1.02	1.08	1.03
16200	1.37	1.37	1.38	1.36	1.38	1.30	1.30	1.07	1.12	1.12	1.08	1.10	1.03
16600	1.42	1.43	1.43	1.41	1.44	1.36	1.39	1.09	1.16	1.16	1.15	1.16	1.08
17000	1.46	1.47	1.44	1.44	1.46	1.40	1.45	1.12	1.21	1.21	1.22	1.23	1.15
17400	1.47	1.49	1.45	1.45	1.47	1.41	1.50	1.17	1.26	1.25	1.30	1.31	1.20
17800	1.47	1.50	1.44	1.45	1.46	1.42	1.53	1.21	1.30	1.29	1.36	1.37	1.25
18000	1.46	1.50	1.44	1.45	1.46	1.42	1.54	1.22	1.31	1.30	1.38	1.39	1.26



P.O. Box 350166, Brooklyn, New York 11235-0003 (718) 934-4500 • Fax (718) 332-4661 For detailed performance specs & shopping online see Mini-Circuits web site
 The Design Engineers Search Engine Provides ACTUAL Data Instantly From MINI-CIRCUITS At: www.minicircuits.com

REV. OR
 RC-2SP6T-A18
 7/17/2020
 Page 2 of 2

Xtra Long Life

USB/ETHERNET RF SP6T SWITCH MATRIX

RC-2SP6T-A18

Typical Performance Data (per Switch)

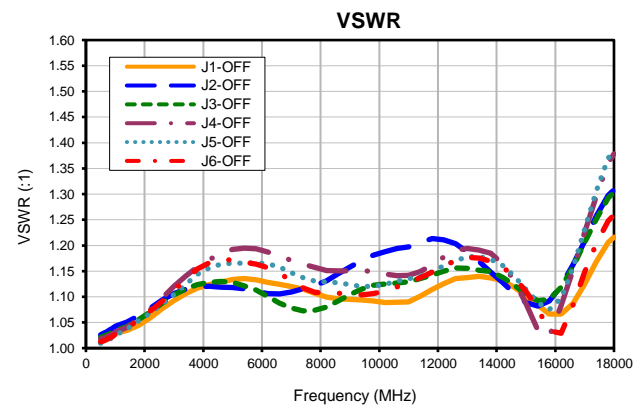
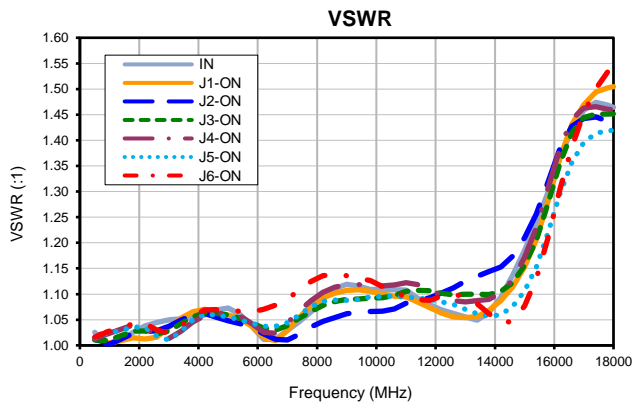
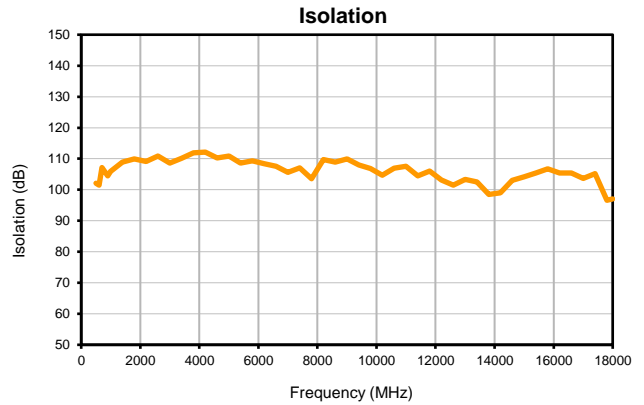
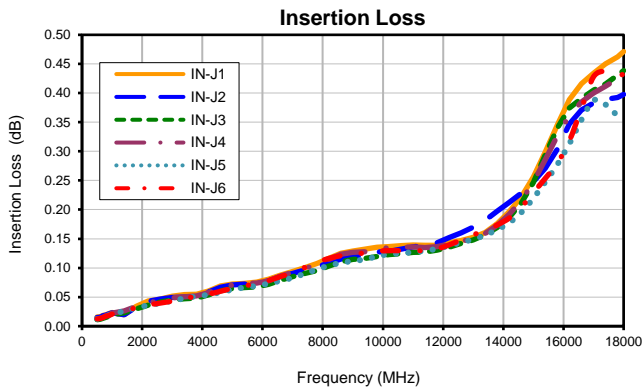

Outline Dimensions

PF2018

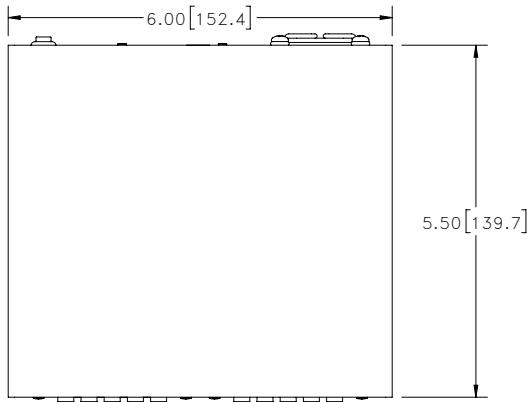

TOP VIEW

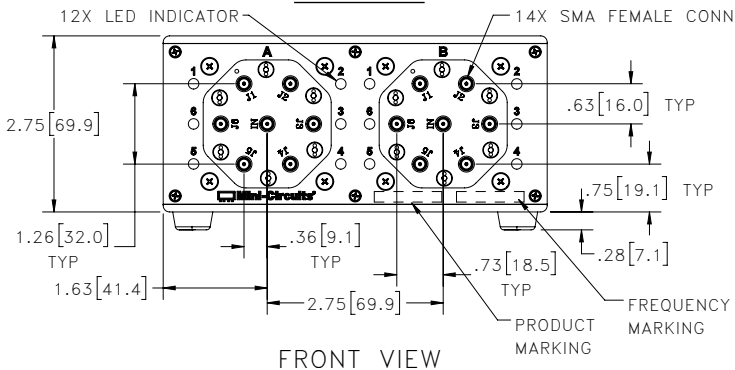

FRONT VIEW

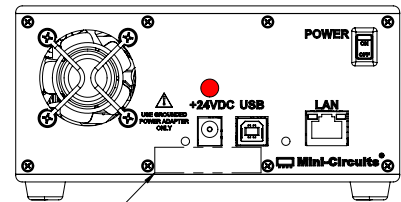

REAR VIEW

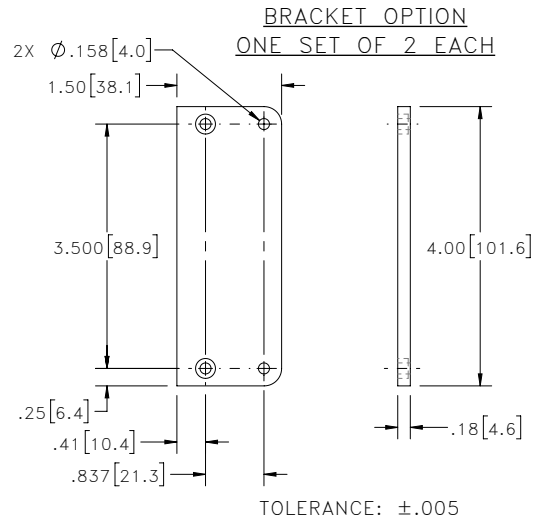

TOLERANCE: ±.005

INSTRUCTIONS FOR MOUNTING BRACKETS:
 TOOL REQUIRED: PHILLIPS HEAD SCREWDRIVER
 STEP 1: REMOVE RUBBER FEET FROM THE BOTTOM OF THE UNIT. DO NOT DISCARD THE FASTENERS.
 STEP 2: MOUNT THE BRACKETS WITH THE FASTENERS REMOVED IN STEP 1, USING THE COUNTER BORE HOLES IN THE BRACKET.

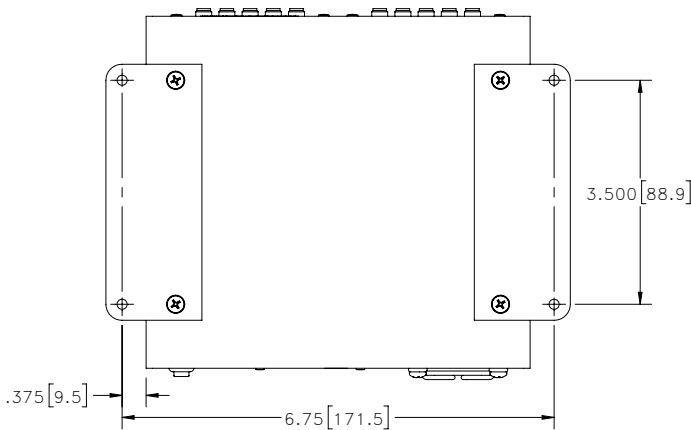

BOTTOM VIEW

SHOWN WITH RUBBER FEET REMOVED AND BRACKETS INSTALLED.

Notes:

1. Case material: Aluminum (with protective coating to prevent corrosion).
2. Dimensions are in inches [mm]. Tolerances: 2 Pl. ±.03 inch; 3 Pl. ±.015 inch.
3. Weight: 1350 grams.
4. Marking may contain other features or characters for internal lot control.



P.O. Box 350166, Brooklyn, New York 11235-0003 (718) 934-4500 Fax (718) 332-4661 For detailed performance specs & shopping online see Mini-Circuits web site



The Design Engineers Search Engine Provides ACTUAL Data Instantly From MINI-CIRCUITS At: www.minicircuits.com

RF/IF MICROWAVE COMPONENTS



All Mini-Circuits products are manufactured under exacting quality assurance and control standards, and are capable of meeting published specifications after being subjected to any or all of the following physical and environmental test.

Specification	Test/Inspection Condition	Reference/Spec
Operating Temperature	0° to 40° C Ambient Environment	Individual Model Data Sheet
Storage Temperature	-15° to 85°C Ambient Environment	Individual Model Data Sheet
Operating and Storage Humidity	5% to 85% RH (non-condensing)	Ambient
Bench Handling Test	Bench Top Tip 45° & Drop	MIL-PRF-28800F
Transit Drop Test	Free Fall Drop, 20 cm (7.9 inches)	MIL-PRF-28800F class 3