



SURFACE MOUNT

Directional Coupler **RDC14.5-182M75+**

75Ω 5 to 1800 MHz 14.5 dB Coupling Great Flatness

KEY FEATURES

- Low Mainline Loss 0.9 dB Typ.
- Good Return Loss 20 dB Typical up to 1800 MHz
- Great Coupling Flatness, ± 0.2 dB Typ.

APPLICATIONS

- CATV /Broadband
- DOCSIS 4.0

PRODUCT OVERVIEW

Mini-Circuits' RDC14.5-182M75+ surface mount directional coupler provides 14.5 dB coupling with low mainline loss and excellent coupling flatness for 75Ω applications from 5 to 1800 MHz. This model features a core and wire design with an all welded construction.



Generic photo used for illustration purposes only

FUNCTIONAL DIAGRAM

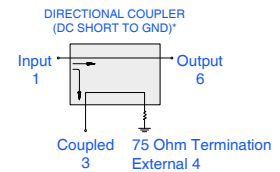

^{*}Electrical schematic is for Directional coupler with transformer(s) and external termination

ELECTRICAL SPECIFICATIONS AT +25°C

Parameter	Frequency (MHz)	Min.	Typ.	Max.	Units
Frequency Range		5		1800	MHz
Mainline Loss ¹ (In-Out)	5 - 1225	—	0.9	1.4	dB
	1225 - 1800	—	1.2	1.7	
Coupling, Nominal	5 - 1800	—	14.5 \pm 0.6	—	dB
Coupling Flatness	5 - 1225	—	± 0.2	± 0.6	dB
	1225 - 1800	—	± 0.3	± 0.6	
Isolation (Out-CPLF)	5 - 1225	25	30	—	dB
	1225 - 1800	22	27	—	
Return Loss (Input)	5 - 1225	16	20	—	dB
	1225 - 1800	16.5	21	—	
Return Loss (Output)	5 - 1225	18.5	23	—	dB
	1225 - 1800	17	20	—	
Return Loss (Coupled)	5 - 1225	16.5	21	—	dB
	1225 - 1800	17	20	—	

1. Mainline Loss includes coupling loss.

ABSOLUTE MAXIMUM RATINGS²

Operating Case Temperature	-40°C to +85°C
Storage Temperature	-55°C to +100°C
Input Power	2 W

2. Permanent damage may occur if any of these limits are exceeded.





SURFACE MOUNT

Directional Coupler

RDC14.5-182M75+

Mini-Circuits

75Ω 5 to 1800 MHz 14.5 dB Coupling Great Flatness

TYPICAL PERFORMANCE GRAPHS

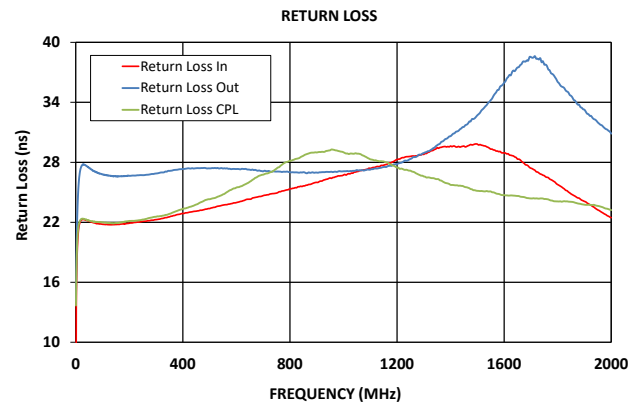
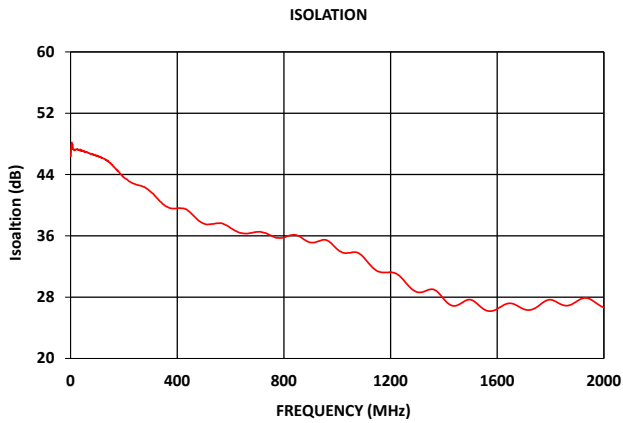
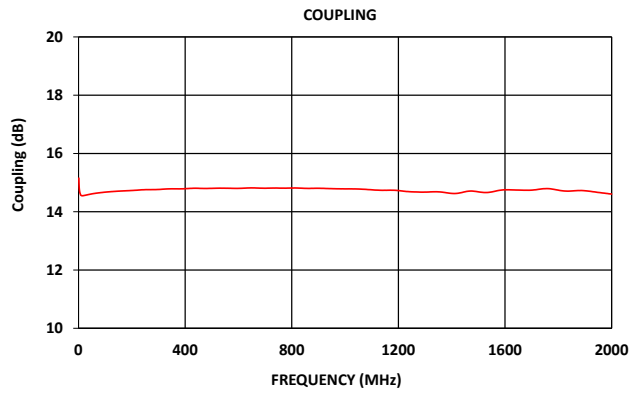
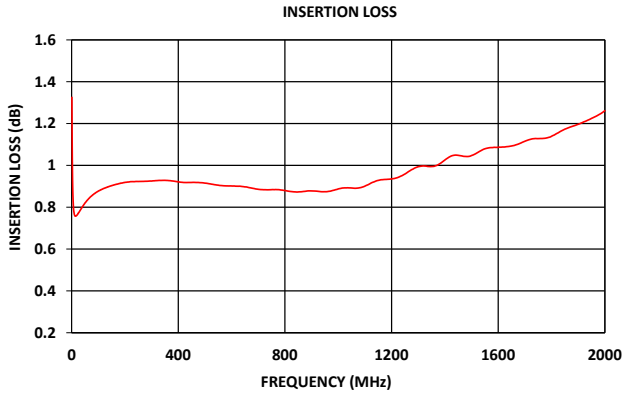



SURFACE MOUNT

Directional Coupler **RDC14.5-182M75+**

75Ω 5 to 1800 MHz 14.5 dB Coupling Great Flatness

FUNCTIONAL DIAGRAM

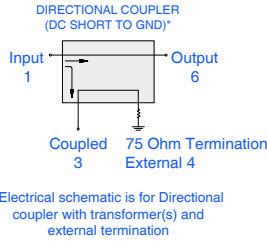

Figure 1. RDC14.5-182M75+ Functional Diagram

PAD DESCRIPTION/CONFIGURATION

Function	Pad Number	Description
Input	1	Connects to RF Input Port
Output	6	Connects to RF Output Port
Coupled	3	Connects to Coupled Port
Ground	2,5	Connects to Ground
75 Ohm Termination External	4	Connects to External 75 Ohm

SUGGESTED PCB LAYOUT (PL-831)

SUGGESTED MOUNTING CONFIGURATION FOR TT2315-3 CASE STYLE

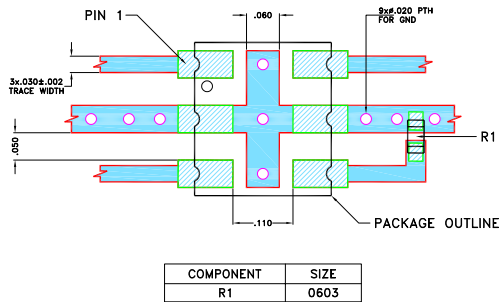

NOTES:

- TRACE WIDTH IS SHOWN FOR ROGERS (R04350B) WITH DIELECTRIC THICKNESS $\# .030 \pm .002$; COPPER: 1/2 Oz ON EACH SIDE. FOR OTHER MATERIALS TRACE WIDTH MAY NEED TO BE MODIFIED.
- BOTTOM SIDE OF THE PCB IS CONTINUOUS GROUND PLANE.
- CHIP COMPONENT FOOT PRINT SHOWN FOR REFERENCE. FOR COMPONENT VALUE REFER TO INDIVIDUAL MODEL EVALUATION BOARD.

- DENOTES PCB COPPER LAYOUT WITH SMOBC (SOLDER MASK OVER BARE COPPER)
- DENOTES COPPER LAND PATTERN FREE OF SOLDERMASK

Figure 2. Suggested PCB Layout PL-831

CASE STYLE DRAWING

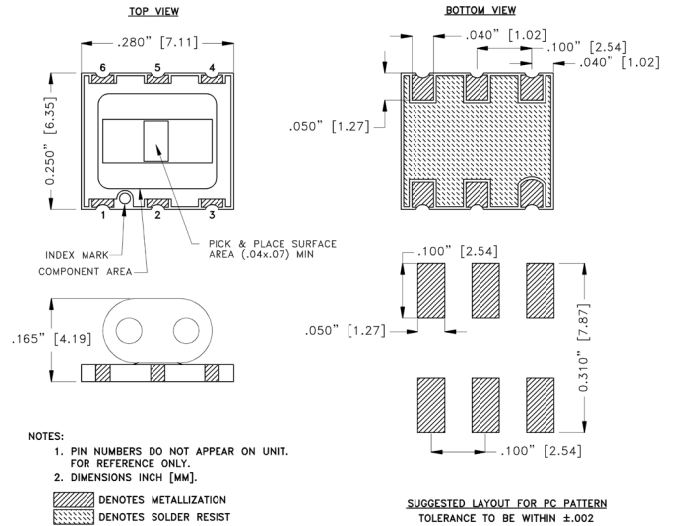

Weight: 0.15 gram

Dimensions are in inches (mm). Tolerances: 2PI. $\pm .01$ [.25]; 3PI. $\pm .005$ [.127]

PRODUCT MARKING*: N/A

*Marking may contain other features or characters for internal lot control.



SURFACE MOUNT

Directional Coupler **RDC14.5-182M75+**

75Ω 5 to 1800 MHz 14.5 dB Coupling Great Flatness

ADDITIONAL DETAILED INFORMATION IS AVAILABLE ON OUR DASHBOARD.

CLICK HERE

Performance Data & Graphs	Data Graphs S-Parameter (S4P Files) Data Set (.zip file) De-embedded to device pads
Case Style	TT2315-3 Lead Finish: Gold over Nickel Plate
RoHS Status	Compliant
Tape and Reel	F34
Suggested Layout for PCB Design	PL-831
Evaluation Board	TBRDC145182M75+
	Gerber File
Environmental Rating	ENV02T1

NOTES

- A. Performance and quality attributes and conditions not expressly stated in this specification document are intended to be excluded and do not form a part of this specification document.
- B. Electrical specifications and performance data contained in this specification document are based on Mini-Circuits' applicable established test performance criteria and measurement instructions.
- C. The parts covered by this specification document are subject to Mini-Circuits' standard limited warranty and terms and conditions (collectively, "Standard Terms"); Purchasers of this part are entitled to the rights and benefits contained therein. For a full statement of the standard terms and the exclusive rights and remedies thereunder, please visit Mini-Circuits' website at www.minicircuits.com/terms/viewterm.html



Directional Coupler

RDC14.5-182M75+

Typical Performance Data

FREQUENCY (MHz)	INSERTION LOSS ⁽¹⁾ (dB)	COUPLING (dB)	ISOLATION (dB)	RETURN LOSS (dB)		
				IN	OUT	CPL
3	0.98	14.77	47.79	17.45	19.22	17.67
5	0.85	14.65	48.19	19.36	21.96	19.57
7	0.80	14.60	47.98	20.48	23.74	20.67
10	0.77	14.56	47.38	21.39	25.48	21.52
20	0.76	14.56	47.23	22.21	27.53	22.29
50	0.82	14.61	47.07	22.09	27.44	22.17
100	0.88	14.67	46.49	21.79	26.81	22.00
108	0.88	14.68	46.30	21.78	26.77	21.96
150	0.90	14.71	45.47	21.79	26.58	21.93
200	0.92	14.73	43.62	21.93	26.65	22.14
250	0.92	14.76	42.65	22.11	26.71	22.27
300	0.93	14.76	41.77	22.29	26.88	22.56
350	0.93	14.79	40.06	22.60	27.14	22.85
400	0.92	14.79	39.59	22.89	27.33	23.35
450	0.92	14.80	39.01	23.14	27.41	23.78
500	0.92	14.80	37.60	23.42	27.39	24.31
550	0.91	14.81	37.64	23.74	27.38	24.79
600	0.90	14.80	37.03	24.01	27.33	25.48
650	0.90	14.82	36.32	24.32	27.26	26.06
700	0.89	14.81	36.52	24.70	27.09	26.76
750	0.88	14.81	36.07	24.97	27.07	27.37
800	0.88	14.81	35.79	25.35	27.02	28.14
850	0.87	14.80	36.05	25.64	27.01	28.65
900	0.88	14.81	35.13	25.99	26.98	28.98
950	0.87	14.79	35.49	26.39	27.04	29.20
1000	0.89	14.78	34.26	26.79	27.10	29.00
1050	0.89	14.78	33.79	27.09	27.23	28.87
1100	0.90	14.75	33.17	27.43	27.27	28.30
1150	0.93	14.74	31.40	27.75	27.53	28.09
1200	0.94	14.73	31.26	28.32	27.84	27.47
1225	0.94	14.70	30.99	28.53	28.10	27.28
1300	0.99	14.68	28.66	28.89	28.93	26.58
1400	1.03	14.63	27.74	29.56	30.61	25.74
1450	1.05	14.68	26.94	29.54	31.55	25.57
1500	1.05	14.68	27.67	29.73	32.71	25.15
1700	1.12	14.74	26.44	27.36	38.53	24.39
1800	1.14	14.74	27.66	25.70	36.04	24.09
1900	1.20	14.72	27.49	24.04	33.27	23.76
2000	1.26	14.61	26.64	22.39	30.87	23.22

⁽¹⁾Mainline loss includes coupling loss.

Typical Performance Curves

INSERTION LOSS

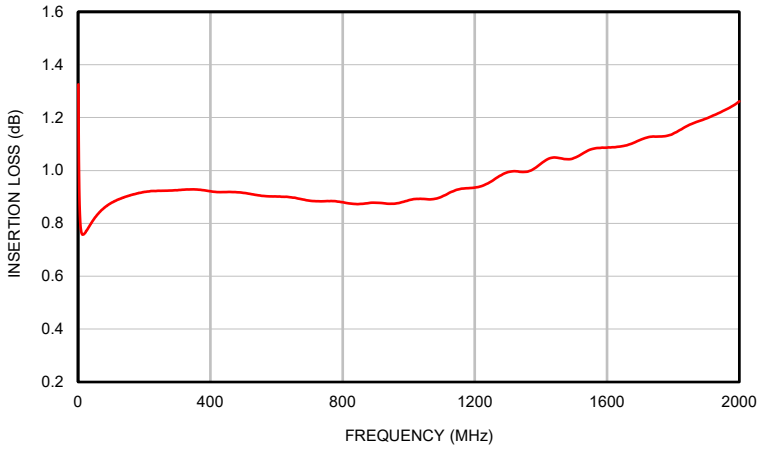

COUPLING

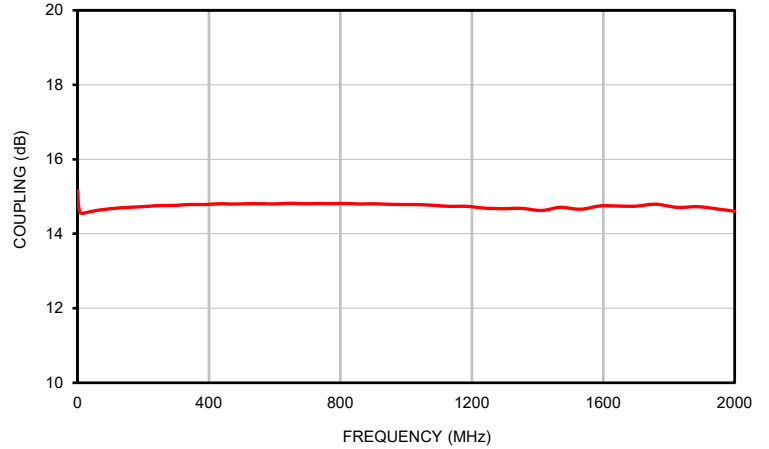

ISOLATION

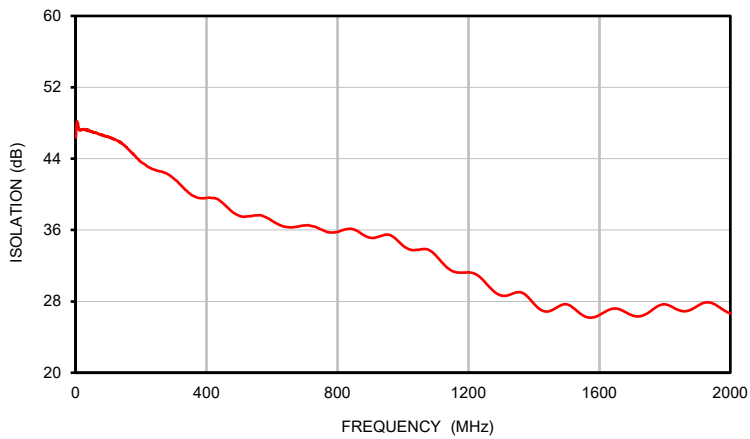

RETURN LOSS

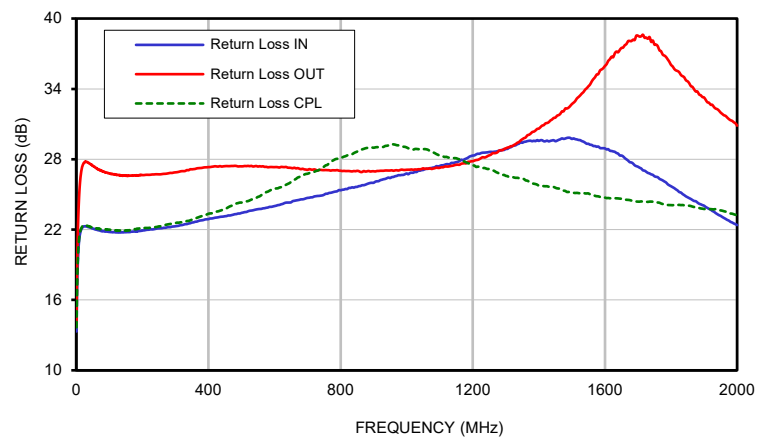

Outline Dimensions

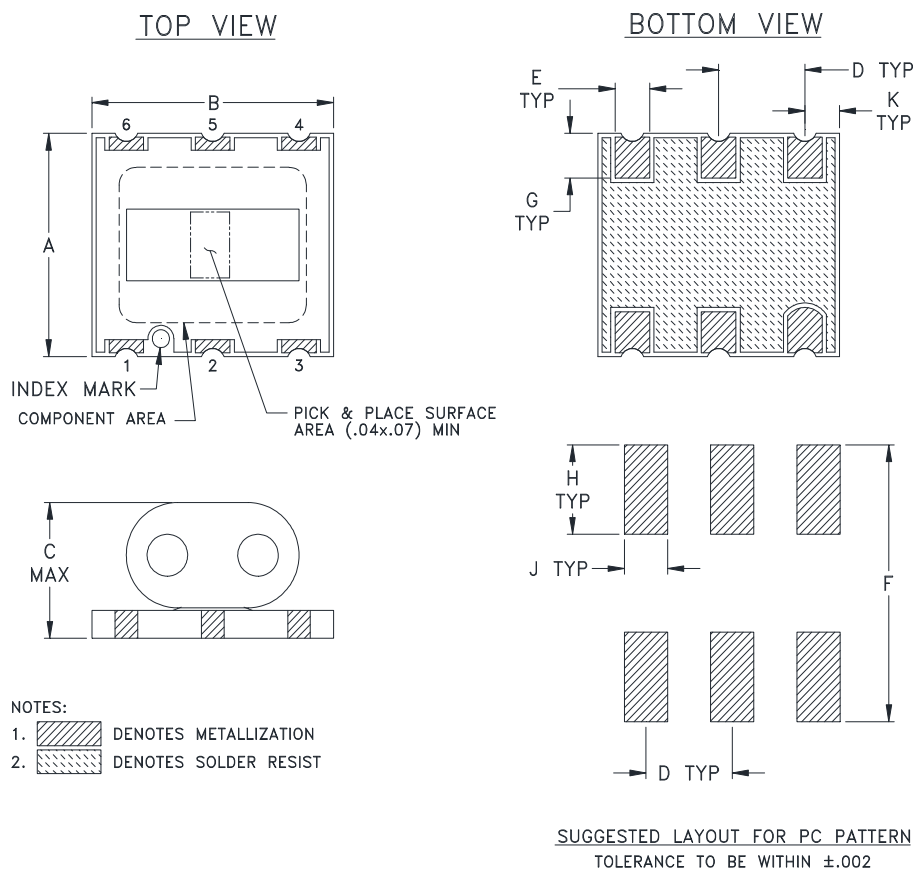

CASE#	A	B	C	D	E	F	G	H	J	K	WT. GRAMS
TT2315-3	.250 (6.35)	.280 (7.11)	.165 (4.19)	.100 (2.54)	.040 (1.02)	.310 (7.87)	.050 (1.27)	.100 (2.54)	.050 (1.27)	.040 (1.02)	0.2

Dimensions are in (mm). Tolerances : 2 Pl.±.01[.25]; 3 Pl.±.005[0.127]

Notes:

1. Case material : Printed wiring laminate.
2. Termination finished : 3-5 μ inch (.08-.13 microns) Gold over 120-240 μ inch (3.05-6.10 microns) Nickel plate. All models, (+) suffix.
3. Orientation dot on Core & PCB corresponds to Pin # 1.



P.O. Box 350166, Brooklyn, New York 11235-0003 (718) 934-4500 Fax (718) 332-4661 For detailed performance specs & shopping online see Mini-Circuits web site



The Design Engineers Search Engine Provides ACTUAL Data Instantly From MINI-CIRCUITS At: www.minicircuits.com

RF/IF MICROWAVE COMPONENTS

Tape & Reel Packaging TR-F34



Tape Width, mm	Device Cavity Pitch, mm	Reel Size, inches	Devices per Reel see note	
16	12	7	Small quantity standard (see note)	20
				50
			100	
			200	
		13	Standard	500
				1000

Note: Availability of small reel quantity varies by model.
Refer to pricing and availability on individual model dashboard.

Mini-Circuits carrier tape materials provide protection from ESD (Electro-Static Discharge) during handling and transportation. Tapes are static dissipative and comply with industry standards EIA-481/EIA-541.

Go to: www.minicircuits.com/pages/pdfs/tape.pdf



INTERNET <http://www.minicircuits.com>

P.O. Box 350166, Brooklyn, New York 11235-0003 (718) 934-4500 Fax (718) 332-4661

Distribution Centers NORTH AMERICA 800-654-7949 • 417-335-5935 • Fax 417-335-5945 • EUROPE 44-1252-832600 • Fax 44-1252-837010

Mini-Circuits ISO 9001 & ISO 14001 Certified

THIRD ANGLE PROJECTION

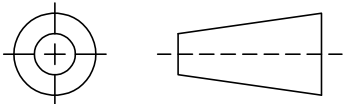

REVISIONS

REV	ECN No.	DESCRIPTION	DATE	DR	AUTH
OR	ECO-026422	NEW RELEASE	AUG 25	DDR	VC

SUGGESTED MOUNTING CONFIGURATION
FOR TT2315-3 CASE STYLE

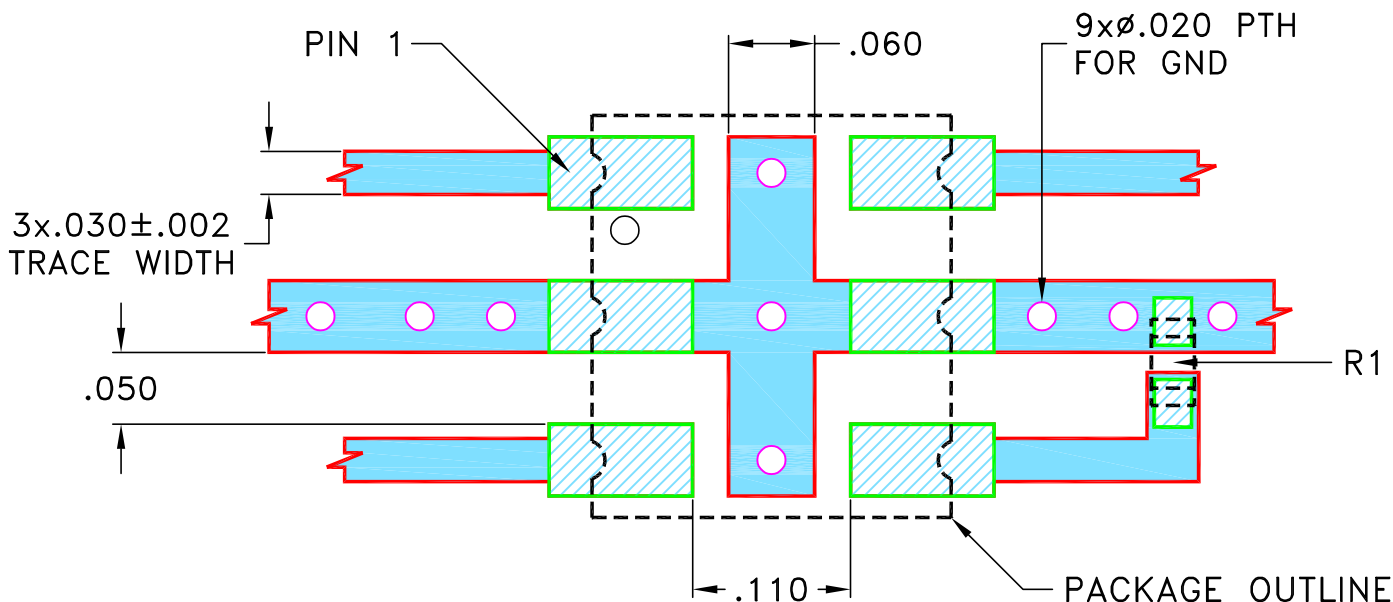

COMPONENT	SIZE
R1	0603

NOTES:

- TRACE WIDTH IS SHOWN FOR ROGERS (R04350B) WITH DIELECTRIC THICKNESS $\varnothing.030\pm.002$; COPPER: 1/2 oz ON EACH SIDE.
FOR OTHER MATERIALS TRACE WIDTH MAY NEED TO BE MODIFIED.
- BOTTOM SIDE OF THE PCB IS CONTINUOUS GROUND PLANE.
- CHIP COMPONENT FOOT PRINT SHOWN FOR REFERENCE.
FOR COMPONENT VALUE REFER TO INDIVIDUAL MODEL EVALUATION BOARD.

- DENOTES PCB COPPER LAYOUT WITH SMOBC (SOLDER MASK OVER BARE COPPER)
- DENOTES COPPER LAND PATTERN FREE OF SOLDERMASK

UNLESS OTHERWISE SPECIFIED	INITIALS	DATE
DRAWN	DDR	04 AUG 25
CHECKED	MKS	04 AUG 25
APPROVED	ASJ	04 AUG 25



Mini-Circuits®

13 Neptune Avenue
Brooklyn NY 11235

PL, 75, TT2315-3, TB-1133+

Mini-Circuits®
THIS DOCUMENT AND ITS CONTENTS ARE THE PROPERTY OF MINI-CIRCUITS. EXCEPT FOR USE EXPRESSLY GRANTED, IN WRITING, TO ITS VENDORS, VENDEE AND THE UNITED STATES GOVERNMENT, MINI-CIRCUITS RESERVES ALL PROPRIETARY DESIGN, USE, MANUFACTURING AND REPRODUCTION RIGHTS THERETO. THESE CONTENTS SHALL NOT BE USED, DUPLICATED OR DISCLOSED TO ANY OUTSIDE PARTY, IN WHOLE OR IN PART, WITHOUT WRITTEN PERMISSION OF MINI-CIRCUITS.

SIZE	CODE IDENT	DRAWING NO:	REV:
A	15542	98-PL-831	OR
FILE: 98-PL-831	SCALE: 7:1	SHEET: 1 OF 1	

Evaluation Board and Circuit

TBRDC145182M75+

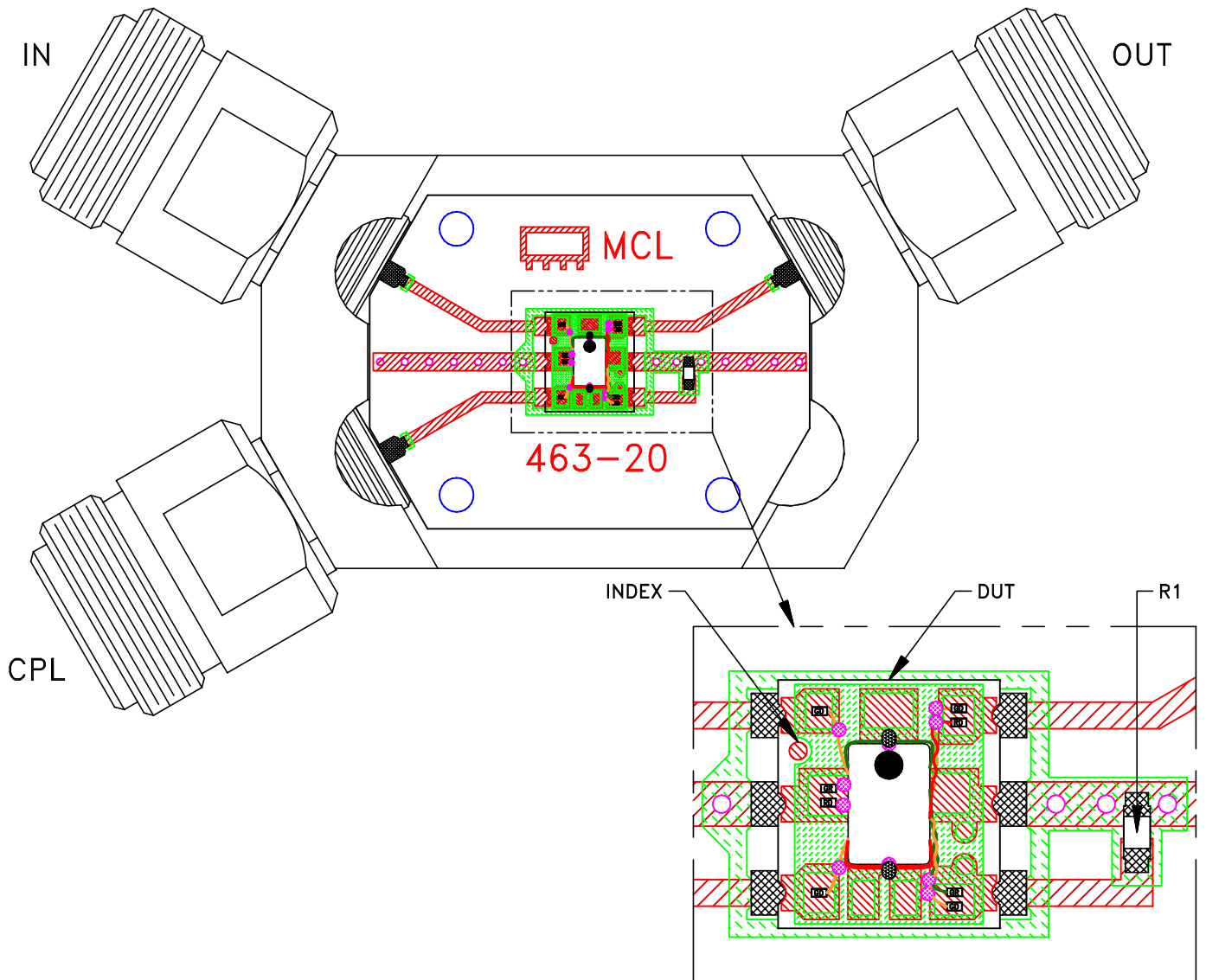

Schematic Diagram

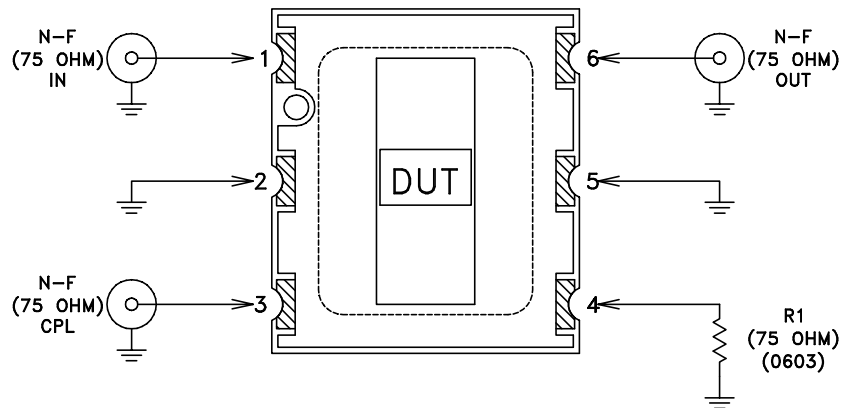

Notes:

1. PCB Material: ROGERS (R04350B) OR Equivalent, Dielectric Constant=3.48
Thickness=.030±.002 inch
2. 75 Ohm N Female Connector.

 **Mini-Circuits®**

All Mini-Circuits products are manufactured under exacting quality assurance and control standards, and are capable of meeting published specifications after being subjected to any or all of the following physical and environmental test.

Specification	Test/Inspection Condition	Reference/Spec
Operating Temperature	-40° to 85°C Ambient Environment	Individual Model Data Sheet
Storage Temperature	-55° to 100° C Ambient Environment	Individual Model Data Sheet
Humidity	90 to 95% RH, 240 hours, 50°C	MIL-STD-202, Method 103, Condition A, Except 50°C and end-point electrical test done within 12 hours
Thermal Shock	-55° to 100°C, 100 cycles	MIL-STD-202, Method 107, Condition A-3, except +100°C
Solder Reflow Heat	Sn-Pb Eutetic Process: 225°C peak Pb-Free Process 245° - 250°C peak	J-STD-020, Table 4-1, 4-2 and 5-2, Figure 5-1
Solderability	10X Magnification	J-STD-002, 95% Coverage
Vibration (High Frequency)	20g peak, 10-2000 Hz, 12 times in each of three perpendicular directions (total 36)	MIL-STD-202, Method 204, Condition D
Mechanical Shock	50g, 11 ms, 1/2-sine, 18 shocks: 3 each direction, each of 3 axes	MIL-STD-202, Method 213, Condition A
Marking Resistance to Solvents	Isopropyl alcohol + mineral spirits at 25°C; terpene defluxer at 25°C; distilled water + proylene glycol monomethyl ether + monoethanolamine at 63°C to 70°C	MIL-STD-202, Method 215