



SURFACE MOUNT

Directional Coupler

RDC17.5-182M75+

75Ω 5 to 1800 MHz 17.5 dB Coupling Great Flatness

KEY FEATURES

- Low Mainline Loss 0.8 dB Typ.
- Good Return Loss 20 dB Typical up to 1800 MHz
- Great Coupling Flatness, ± 0.3 dB Typ.

APPLICATIONS

- CATV /Broadband
- DOCSIS 4.0

PRODUCT OVERVIEW

Mini-Circuits' RDC17.5-182M75+ surface mount directional coupler provides 17.5 dB coupling with low mainline loss and excellent coupling flatness for 75Ω applications from 5 to 1800 MHz. This model features a core and wire design with an all welded construction.



Generic photo used for illustration purposes only

FUNCTIONAL DIAGRAM

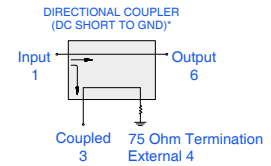

*Electrical schematic is for Directional coupler with transformer(s) and external termination

ELECTRICAL SPECIFICATIONS AT +25°C

| Parameter | Frequency (MHz) | Min. | Typ. | Max. | Units |
|--------------------------------------|-----------------|------|----------------|-----------|-------|
| Frequency Range | | 5 | | 1800 | MHz |
| Mainline Loss ¹ (In-Out) | 5 - 1225 | — | 0.8 | 1.3 | dB |
| | 1225 - 1800 | — | 1 | 1.6 | |
| Coupling, Nominal | 5 - 1225 | — | 17.5 \pm 0.5 | — | dB |
| | 1225 - 1800 | — | 17.5 \pm 0.9 | — | |
| Coupling Flatness | 5 - 1225 | — | ± 0.5 | ± 0.8 | dB |
| | 1225 - 1800 | — | ± 0.3 | ± 0.6 | |
| Isolation (Out-CPLF) | 5 - 1225 | 26 | 32 | — | dB |
| | 1225 - 1800 | 22 | 26 | — | |
| Return Loss (Input) | 5 - 50 | 16 | 20 | — | dB |
| | 50 - 1225 | 21 | 25 | — | |
| | 1225 - 1800 | 16.5 | 20 | — | |
| Return Loss (Output) | 5 - 50 | 18 | 23 | — | dB |
| | 50 - 1225 | 22 | 25 | — | |
| | 1225 - 1800 | 16 | 20 | — | |
| Return Loss (Coupled) | 5 - 50 | 16 | 22 | — | dB |
| | 50 - 1225 | 20 | 25 | — | |
| | 1225 - 1800 | 19 | 22 | — | |

1. Mainline Loss includes coupling loss.

ABSOLUTE MAXIMUM RATINGS²

| | |
|----------------------------|-----------------|
| Operating Case Temperature | -40°C to +85°C |
| Storage Temperature | -55°C to +100°C |
| Input Power | 2 W |

2. Permanent damage may occur if any of these limits are exceeded.





SURFACE MOUNT

Directional Coupler

RDC17.5-182M75+

Mini-Circuits

75Ω 5 to 1800 MHz 17.5 dB Coupling Great Flatness

TYPICAL PERFORMANCE GRAPHS

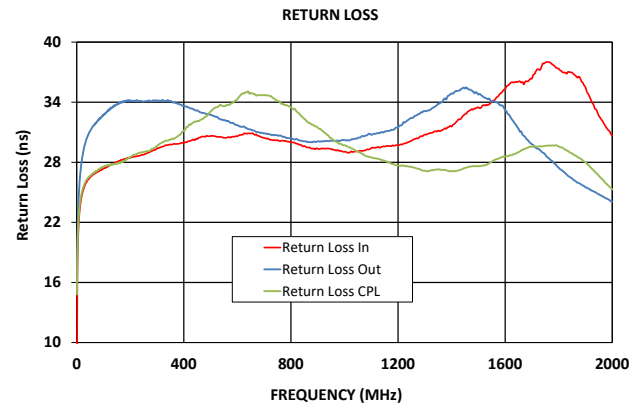
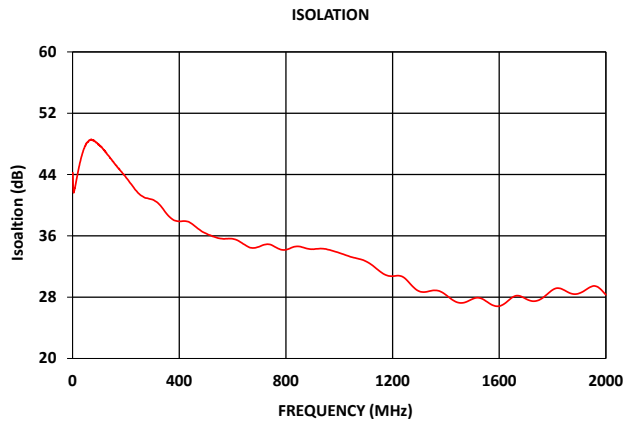
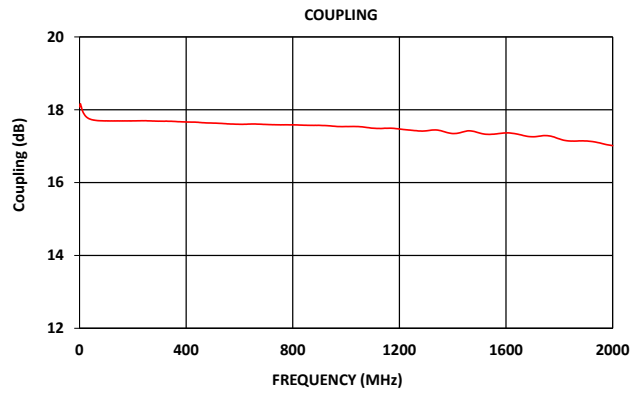
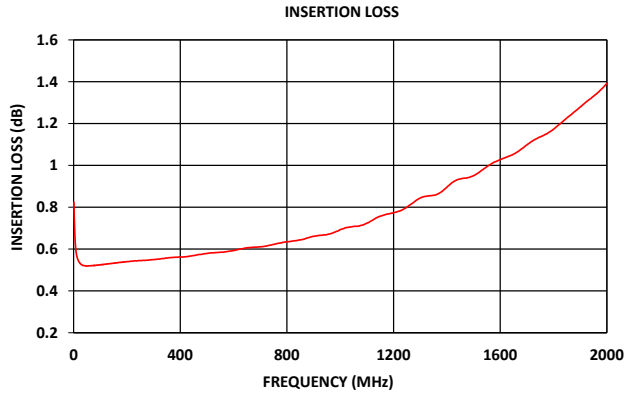



SURFACE MOUNT

Directional Coupler

RDC17.5-182M75+

75Ω 5 to 1800 MHz 17.5 dB Coupling Great Flatness

FUNCTIONAL DIAGRAM

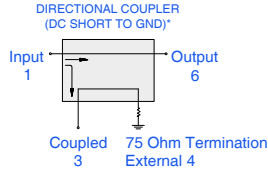

*Electrical schematic is for Directional coupler with transformer(s) and external termination

Figure 1. RDC17.5-182M75+ Functional Diagram

PAD DESCRIPTION/CONFIGURATION

| Function | Pad Number | Description |
|-----------------------------|------------|-----------------------------|
| Input | 1 | Connects to RF Input Port |
| Output | 6 | Connects to RF Output Port |
| Coupled | 3 | Connects to Coupled Port |
| Ground | 2,5 | Connects to Ground |
| 75 Ohm Termination External | 4 | Connects to External 75 Ohm |

CASE STYLE DRAWING

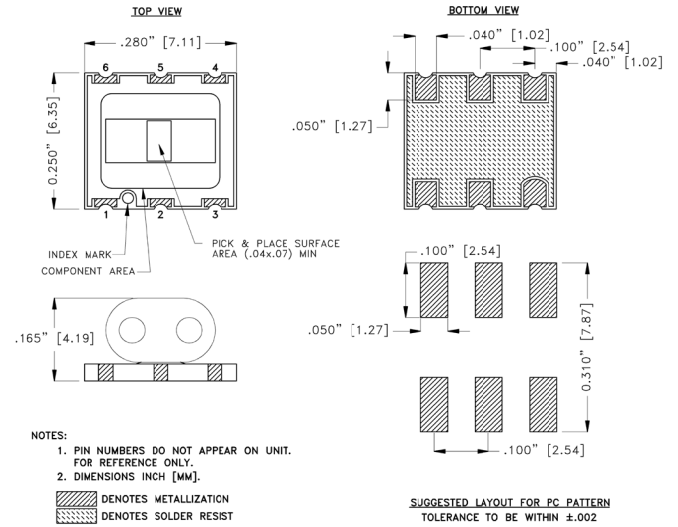

Weight: 0.15 gram
Dimensions are in inches (mm). Tolerances: 2PI. ± .01[.25]; 3PI. ± .005[.127]

SUGGESTED PCB LAYOUT (PL-831)

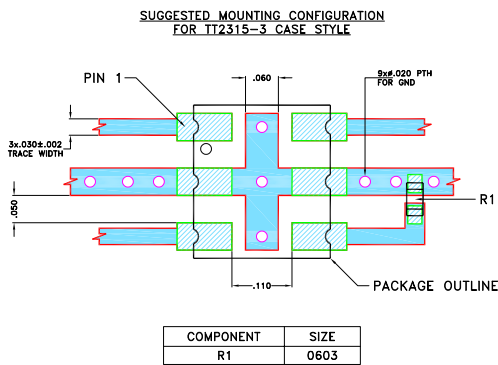

- NOTES:**
- TRACE WIDTH IS SHOWN FOR ROGERS (R04350B) WITH DIELECTRIC THICKNESS $0.030 \pm .002$; COPPER: 1/2 Oz ON EACH SIDE. FOR OTHER MATERIALS TRACE WIDTH MAY NEED TO BE MODIFIED.
 - BOTTOM SIDE OF THE PCB IS CONTINUOUS GROUND PLANE.
 - CHIP COMPONENT FOOT PRINT SHOWN FOR REFERENCE. FOR COMPONENT VALUE REFER TO INDIVIDUAL MODEL EVALUATION BOARD.
- DENOTES PCB COPPER LAYOUT WITH SMOBC (SOLDER MASK OVER BARE COPPER)
 - DENOTES COPPER LAND PATTERN FREE OF SOLDERMASK

Figure 2. Suggested PCB Layout PL-831

PRODUCT MARKING*: N/A

*Marking may contain other features or characters for internal lot control.



SURFACE MOUNT

Directional Coupler

RDC17.5-182M75+

75Ω 5 to 1800 MHz 17.5 dB Coupling Great Flatness

Mini-Circuits

ADDITIONAL DETAILED INFORMATION IS AVAILABLE ON OUR DASHBOARD.

CLICK HERE

| | |
|---------------------------------|---|
| Performance Data & Graphs | Data |
| | Graphs |
| | S-Parameter (S4P Files) Data Set (.zip file) De-embedded to device pads |
| Case Style | TT2315-3 Lead Finish: Gold over Nickel Plate |
| RoHS Status | Compliant |
| Tape and Reel | F34 |
| Suggested Layout for PCB Design | PL-831 |
| Evaluation Board | TBRDC175182M75+ |
| | Gerber File |
| Environmental Rating | ENV02T1 |

NOTES

- A. Performance and quality attributes and conditions not expressly stated in this specification document are intended to be excluded and do not form a part of this specification document.
- B. Electrical specifications and performance data contained in this specification document are based on Mini-Circuits' applicable established test performance criteria and measurement instructions.
- C. The parts covered by this specification document are subject to Mini-Circuits' standard limited warranty and terms and conditions (collectively, "Standard Terms"); Purchasers of this part are entitled to the rights and benefits contained therein. For a full statement of the standard terms and the exclusive rights and remedies thereunder, please visit Mini-Circuits' website at www.minicircuits.com/terms/viewterm.html



Directional Coupler

RDC17.5-182M75+

Typical Performance Data

| FREQUENCY (MHz) | INSERTION LOSS ⁽¹⁾ (dB) | COUPLING (dB) | ISOLATION (dB) | RETURN LOSS (dB) | | |
|--------------------|---------------------------------------|------------------|-------------------|---------------------|-------|-------|
| | | | | IN | OUT | CPL |
| 3 | 0.73 | 18.16 | 41.92 | 19.39 | 20.68 | 19.51 |
| 5 | 0.66 | 18.11 | 41.75 | 21.05 | 22.76 | 21.23 |
| 7 | 0.62 | 18.07 | 41.95 | 22.12 | 24.24 | 22.35 |
| 10 | 0.58 | 17.99 | 42.45 | 23.20 | 25.75 | 23.42 |
| 20 | 0.54 | 17.85 | 44.29 | 24.90 | 28.39 | 25.10 |
| 50 | 0.52 | 17.72 | 47.90 | 26.52 | 31.11 | 26.67 |
| 100 | 0.53 | 17.70 | 47.85 | 27.39 | 32.74 | 27.56 |
| 108 | 0.53 | 17.70 | 47.59 | 27.46 | 32.91 | 27.65 |
| 150 | 0.53 | 17.69 | 45.80 | 28.00 | 33.78 | 27.87 |
| 200 | 0.54 | 17.70 | 43.63 | 28.49 | 34.17 | 28.52 |
| 250 | 0.55 | 17.70 | 41.47 | 28.84 | 34.08 | 29.04 |
| 300 | 0.55 | 17.69 | 40.73 | 29.41 | 34.18 | 29.65 |
| 350 | 0.56 | 17.68 | 39.00 | 29.77 | 34.13 | 30.26 |
| 400 | 0.56 | 17.67 | 37.90 | 30.02 | 33.66 | 31.18 |
| 450 | 0.57 | 17.65 | 37.51 | 30.45 | 33.18 | 32.14 |
| 500 | 0.58 | 17.63 | 36.32 | 30.65 | 32.73 | 33.06 |
| 550 | 0.59 | 17.62 | 35.68 | 30.45 | 32.19 | 33.61 |
| 600 | 0.59 | 17.60 | 35.62 | 30.69 | 31.70 | 34.31 |
| 650 | 0.61 | 17.61 | 34.74 | 30.89 | 31.28 | 34.92 |
| 700 | 0.61 | 17.60 | 34.59 | 30.39 | 30.88 | 34.73 |
| 750 | 0.62 | 17.59 | 34.74 | 30.14 | 30.68 | 34.10 |
| 800 | 0.64 | 17.59 | 34.19 | 29.98 | 30.39 | 33.48 |
| 850 | 0.64 | 17.58 | 34.61 | 29.55 | 30.09 | 32.34 |
| 900 | 0.66 | 17.57 | 34.26 | 29.32 | 30.10 | 31.47 |
| 950 | 0.67 | 17.55 | 34.29 | 29.31 | 30.15 | 30.41 |
| 1000 | 0.69 | 17.54 | 33.78 | 29.04 | 30.22 | 29.72 |
| 1050 | 0.71 | 17.54 | 33.20 | 29.13 | 30.45 | 29.07 |
| 1100 | 0.72 | 17.49 | 32.68 | 29.48 | 30.74 | 28.51 |
| 1150 | 0.76 | 17.49 | 31.44 | 29.61 | 31.08 | 28.14 |
| 1200 | 0.77 | 17.47 | 30.74 | 29.73 | 31.48 | 27.69 |
| 1225 | 0.78 | 17.45 | 30.80 | 29.91 | 31.96 | 27.64 |
| 1300 | 0.84 | 17.42 | 28.77 | 30.75 | 33.11 | 27.15 |
| 1400 | 0.90 | 17.35 | 28.30 | 31.74 | 34.88 | 27.12 |
| 1450 | 0.94 | 17.41 | 27.27 | 32.86 | 35.37 | 27.44 |
| 1500 | 0.95 | 17.36 | 27.76 | 33.40 | 34.77 | 27.61 |
| 1700 | 1.10 | 17.26 | 27.78 | 36.72 | 29.80 | 29.56 |
| 1800 | 1.17 | 17.20 | 28.94 | 37.18 | 27.46 | 29.58 |
| 1900 | 1.28 | 17.14 | 28.50 | 35.06 | 25.50 | 28.02 |
| 2000 | 1.39 | 17.02 | 28.31 | 30.55 | 24.08 | 25.28 |

⁽¹⁾Mainline loss includes coupling loss.

Typical Performance Curves

INSERTION LOSS

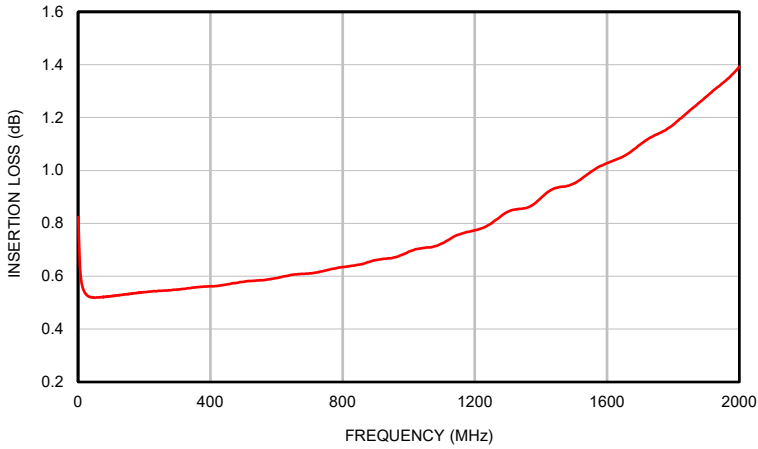

COUPLING

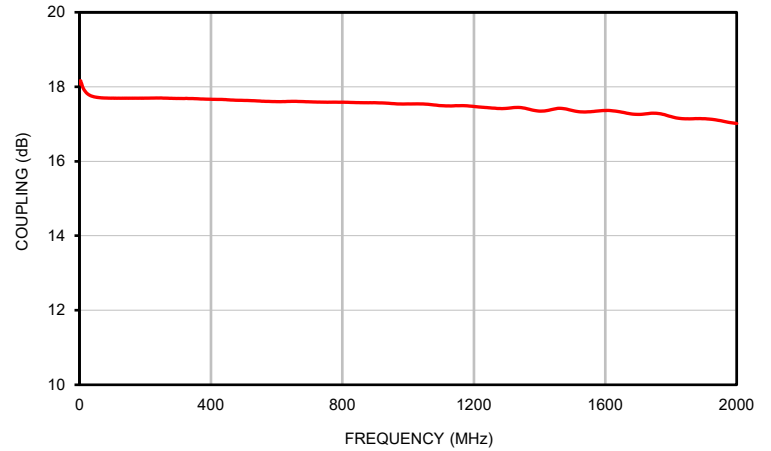

ISOLATION

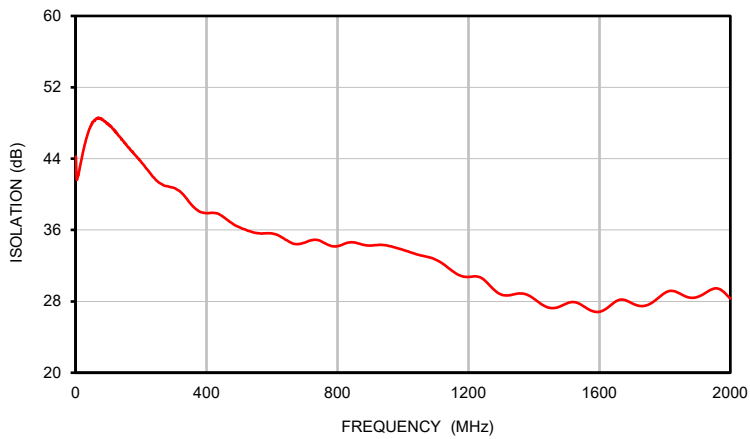

RETURN LOSS

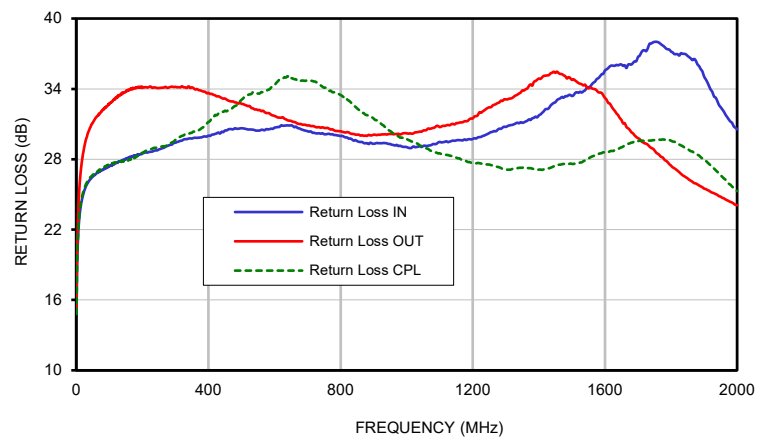

Outline Dimensions

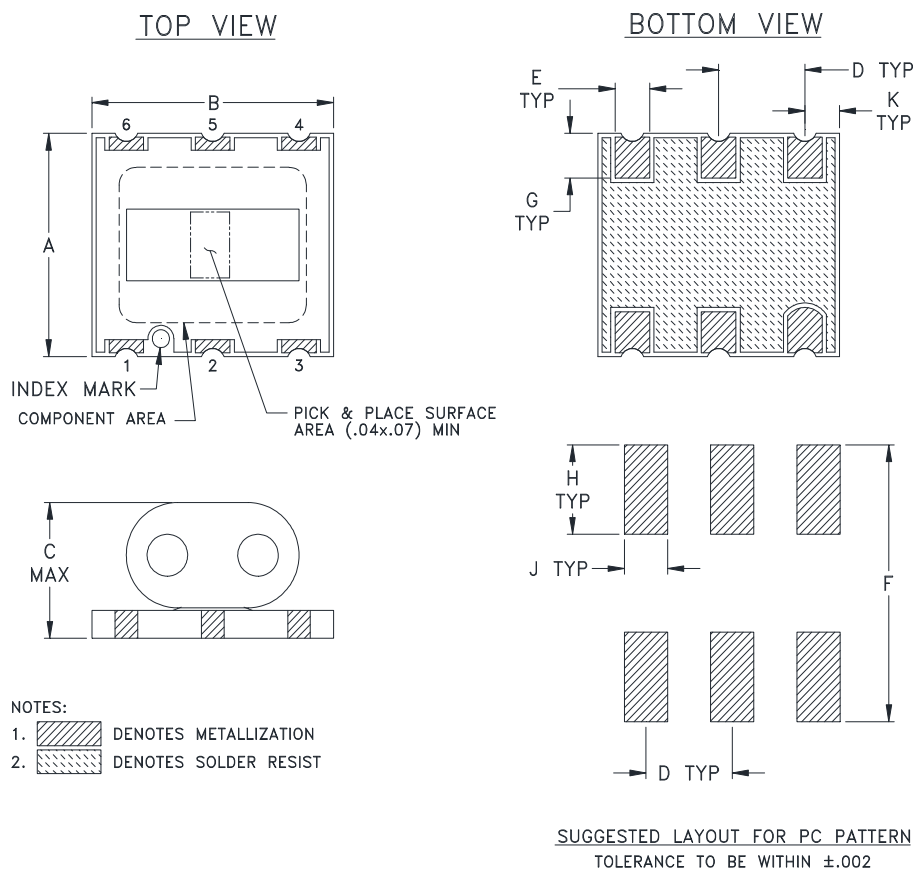

| CASE# | A | B | C | D | E | F | G | H | J | K | WT. GRAMS |
|----------|----------------|----------------|----------------|----------------|----------------|----------------|----------------|----------------|----------------|----------------|-----------|
| TT2315-3 | .250 (6.35) | .280 (7.11) | .165 (4.19) | .100 (2.54) | .040 (1.02) | .310 (7.87) | .050 (1.27) | .100 (2.54) | .050 (1.27) | .040 (1.02) | 0.2 |

Dimensions are in (mm). Tolerances : 2 Pl.±.01[.25]; 3 Pl.±.005[0.127]

Notes:

1. Case material : Printed wiring laminate.
2. Termination finished : 3-5 μ inch (.08-.13 microns) Gold over 120-240 μ inch (3.05-6.10 microns) Nickel plate. All models, (+) suffix.
3. Orientation dot on Core & PCB corresponds to Pin # 1.

Mini-Circuits®
ISO 9001 ISO 14001 CERTIFIED

ALL NEW
minicircuits.com

P.O. Box 350166, Brooklyn, New York 11235-0003 (718) 934-4500 Fax (718) 332-4661 For detailed performance specs & shopping online see Mini-Circuits web site



The Design Engineers Search Engine Provides ACTUAL Data Instantly From MINI-CIRCUITS At: www.minicircuits.com

RF/IF MICROWAVE COMPONENTS

Tape & Reel Packaging TR-F34



| Tape Width, mm | Device Cavity Pitch, mm | Reel Size, inches | Devices per Reel see note | |
|----------------|-------------------------|-------------------|------------------------------------|------|
| 16 | 12 | 7 | Small quantity standard (see note) | 20 |
| | | | | 50 |
| | | | | 100 |
| | | | | 200 |
| | | 13 | Standard | 500 |
| | | | | 1000 |

Note: Availability of small reel quantity varies by model.
Refer to pricing and availability on individual model dashboard.

Mini-Circuits carrier tape materials provide protection from ESD (Electro-Static Discharge) during handling and transportation. Tapes are static dissipative and comply with industry standards EIA-481/EIA-541.

Go to: www.minicircuits.com/pages/pdfs/tape.pdf



INTERNET <http://www.minicircuits.com>

P.O. Box 350166, Brooklyn, New York 11235-0003 (718) 934-4500 Fax (718) 332-4661

Distribution Centers NORTH AMERICA 800-654-7949 • 417-335-5935 • Fax 417-335-5945 • EUROPE 44-1252-832600 • Fax 44-1252-837010

Mini-Circuits ISO 9001 & ISO 14001 Certified

THIRD ANGLE PROJECTION

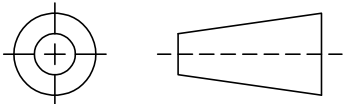

REVISIONS

| REV | ECN No. | DESCRIPTION | DATE | DR | AUTH |
|-----|------------|-------------|--------|-----|------|
| OR | ECO-026422 | NEW RELEASE | AUG 25 | DDR | VC |
| | | | | | |
| | | | | | |

SUGGESTED MOUNTING CONFIGURATION
FOR TT2315-3 CASE STYLE

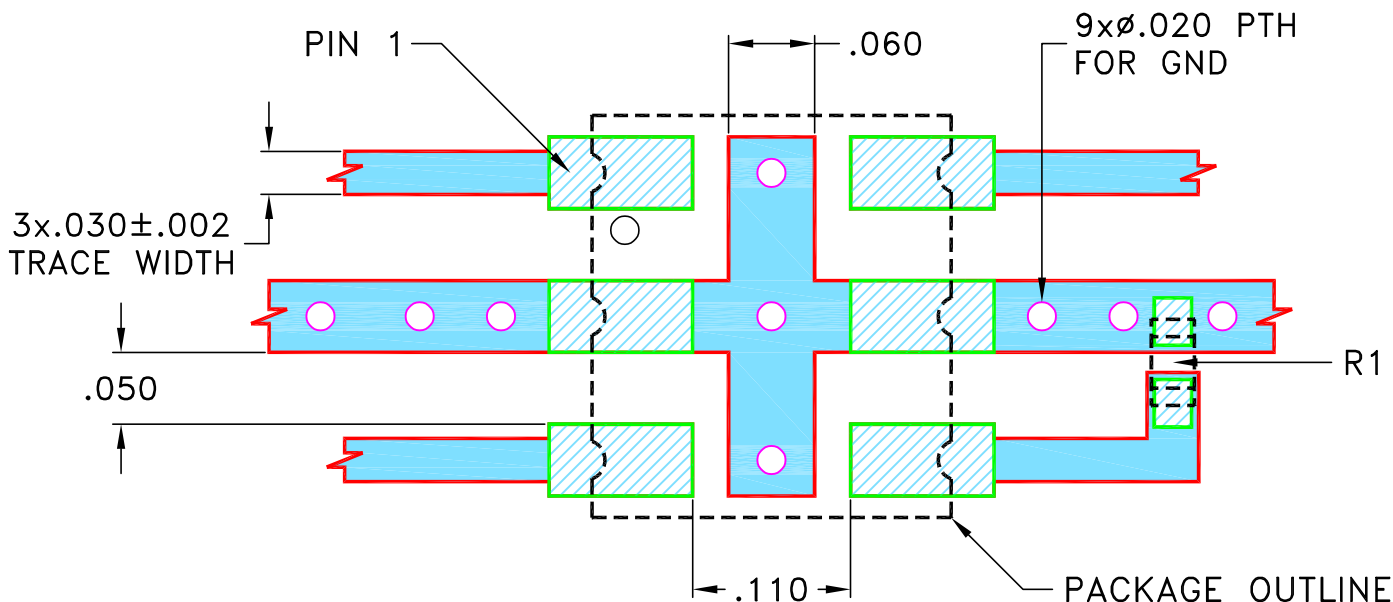

| COMPONENT | SIZE |
|-----------|------|
| R1 | 0603 |

NOTES:

- TRACE WIDTH IS SHOWN FOR ROGERS (R04350B) WITH DIELECTRIC THICKNESS $\phi.030\pm.002$; COPPER: 1/2 Oz ON EACH SIDE.
FOR OTHER MATERIALS TRACE WIDTH MAY NEED TO BE MODIFIED.
- BOTTOM SIDE OF THE PCB IS CONTINUOUS GROUND PLANE.
- CHIP COMPONENT FOOT PRINT SHOWN FOR REFERENCE.
FOR COMPONENT VALUE REFER TO INDIVIDUAL MODEL EVALUATION BOARD.

- DENOTES PCB COPPER LAYOUT WITH SMOBC (SOLDER MASK OVER BARE COPPER)
- DENOTES COPPER LAND PATTERN FREE OF SOLDERMASK

| UNLESS OTHERWISE SPECIFIED | INITIALS | DATE |
|----------------------------|----------|-----------|
| DRAWN | DDR | 04 AUG 25 |
| CHECKED | MKS | 04 AUG 25 |
| APPROVED | ASJ | 04 AUG 25 |



Mini-Circuits®

13 Neptune Avenue
Brooklyn NY 11235

PL, 75, TT2315-3, TB-1133+

Mini-Circuits®
THIS DOCUMENT AND ITS CONTENTS ARE THE PROPERTY OF MINI-CIRCUITS. EXCEPT FOR USE EXPRESSLY GRANTED, IN WRITING, TO ITS VENDORS, VENDEE AND THE UNITED STATES GOVERNMENT, MINI-CIRCUITS RESERVES ALL PROPRIETARY DESIGN, USE, MANUFACTURING AND REPRODUCTION RIGHTS THERETO. THESE CONTENTS SHALL NOT BE USED, DUPLICATED OR DISCLOSED TO ANY OUTSIDE PARTY, IN WHOLE OR IN PART, WITHOUT WRITTEN PERMISSION OF MINI-CIRCUITS.

| SIZE | CODE IDENT | DRAWING NO: | REV: |
|-----------------|------------|---------------|------|
| A | 15542 | 98-PL-831 | OR |
| FILE: 98-PL-831 | SCALE: 7:1 | SHEET: 1 OF 1 | |

Evaluation Board and Circuit

TBRDC175182M75+

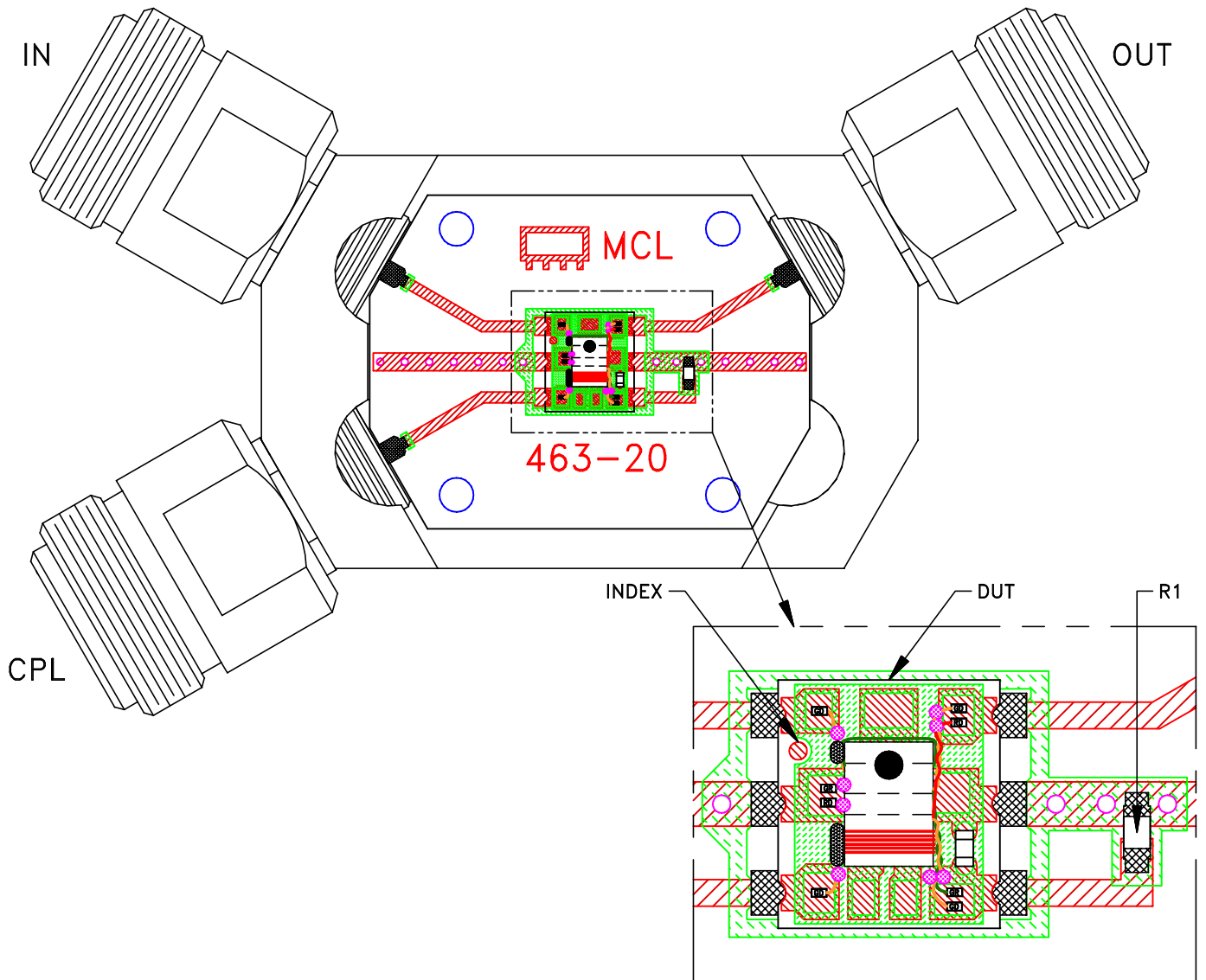

Schematic Diagram

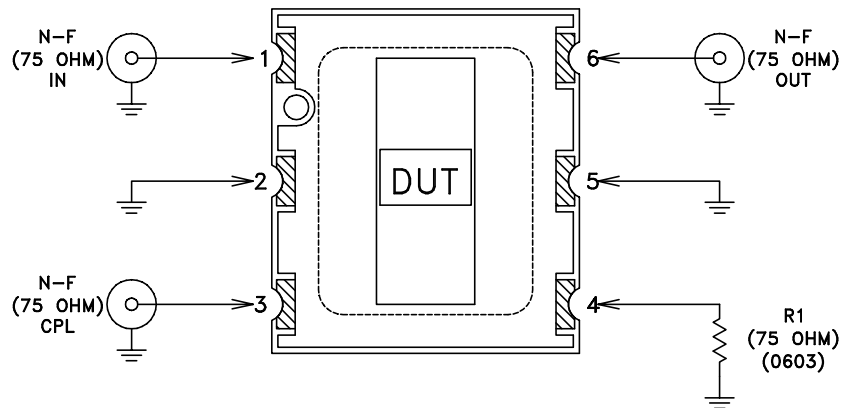

Notes:

1. PCB Material: ROGERS (R04350B) OR Equivalent, Dielectric Constant=3.48
Thickness=.030±.002 inch
2. 75 Ohm N Female Connector.

 **Mini-Circuits®**

All Mini-Circuits products are manufactured under exacting quality assurance and control standards, and are capable of meeting published specifications after being subjected to any or all of the following physical and environmental test.

| Specification | Test/Inspection Condition | Reference/Spec |
|--------------------------------|---|--|
| Operating Temperature | -40° to 85°C Ambient Environment | Individual Model Data Sheet |
| Storage Temperature | -55° to 100° C Ambient Environment | Individual Model Data Sheet |
| Humidity | 90 to 95% RH, 240 hours, 50°C | MIL-STD-202, Method 103, Condition A, Except 50°C and end-point electrical test done within 12 hours |
| Thermal Shock | -55° to 100°C, 100 cycles | MIL-STD-202, Method 107, Condition A-3, except +100°C |
| Solder Reflow Heat | Sn-Pb Eutetic Process: 225°C peak Pb-Free Process 245° - 250°C peak | J-STD-020, Table 4-1, 4-2 and 5-2, Figure 5-1 |
| Solderability | 10X Magnification | J-STD-002, 95% Coverage |
| Vibration (High Frequency) | 20g peak, 10-2000 Hz, 12 times in each of three perpendicular directions (total 36) | MIL-STD-202, Method 204, Condition D |
| Mechanical Shock | 50g, 11 ms, 1/2-sine, 18 shocks: 3 each direction, each of 3 axes | MIL-STD-202, Method 213, Condition A |
| Marking Resistance to Solvents | Isopropyl alcohol + mineral spirits at 25°C; terpene defluxer at 25°C; distilled water + proylene glycol monomethyl ether + monoethanolamine at 63°C to 70°C | MIL-STD-202, Method 215 |