

+5 to +30 dBm

Limiter

RLM-23+

50Ω Broadband 950 to 2050 MHz

The Big Deal

- High CW input power, 1 W
- Very low limiting output power, ≤ 0 dBm typ.
- Very fast response time, 2 nsec



CASE STYLE: CK1246-1

Product Overview

The RLM-23+ protects against damage from unwanted signals over a wide frequency range, 950 to 2050 MHz, at up to 1W power. Construction is on a micro strip low loss dielectric material and cased into a high volume, low cost package for cost efficiencies. Measuring 0.5 x 0.5 x 0.18" high, these tiny units provide excellent protection for IF circuits in satellite receivers, or low noise amplifiers in hostile environments where unwanted signals prevail, such as in manufacturing sites, train tunnels, etc.

Key Features

Feature	Advantages
Limiting abilities from +5 to +30 dBm	Protects against strong undesired signals and prevents burn out of amplifiers and the saturation of sensitive IF circuitry
0 dBm typ. output power	Very low power output prevents saturation of satellite IF circuits, and offers extra protection for expensive, highly sensitive components following the limiter
Very low insertion loss, 0.7 dB typ.	Preserves the strength of low-power signals
Frequency coverage 950 to 2050 MHz	Protection against many sources generating unwanted signals
Response time 2 nsec	Reacts almost instantaneously to limit unwanted high-level signals
Recovery time 8 nsec	Minimal downtime after unwanted signals are removed, with very quick restoration of standard operating levels
Small surface-mount package	Allows convenient placement in amplifiers incorporating this protective device
Low cost	Practical, low-cost solution to protect expensive amplifiers or other sensitive applications from burning out

Notes

- A. Performance and quality attributes and conditions not expressly stated in this specification document are intended to be excluded and do not form a part of this specification document.
B. Electrical specifications and performance data contained in this specification document are based on Mini-Circuit's applicable established test performance criteria and measurement instructions.
C. The parts covered by this specification document are subject to Mini-Circuits standard limited warranty and terms and conditions (collectively, "Standard Terms"); Purchasers of this part are entitled to the rights and benefits contained therein. For a full statement of the Standard Terms and the exclusive rights and remedies thereunder, please visit Mini-Circuits' website at www.minicircuits.com/MCLStore/terms.jsp



+5 to +30 dBm

Limiter

RLM-23+

50Ω Broadband 950 to 2050 MHz



Generic photo used for illustration purposes only

CASE STYLE: CK1246-1

+RoHS Compliant

The +Suffix identifies RoHS Compliance. See our web site for RoHS Compliance methodologies and qualifications

Maximum Ratings

Operating Temperature	-40°C to 85°C
Storage Temperature	-55°C to 100°C
RF Input Power	1.5W

Permanent damage may occur if any of these limits are exceeded.

Pin Connections

INPUT	2
OUTPUT	10
GROUND	all others

Outline Drawing

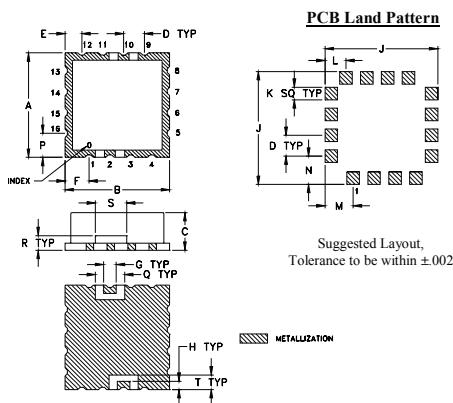

Outline Dimensions (inch/mm)

A	B	C	D	E	F	G	H	J	K
.500	.500	.180	.100	.080	.115	.060	.040	.540	.060
12.70	12.70	4.57	2.54	2.03	2.92	1.52	1.02	13.72	1.52
L	M	N	P	Q	R	S	T	wt.	
.100	.135	.135	.115	.140	.070	.150	.070	grams	
2.54	3.43	3.43	2.92	3.56	1.78	3.81	1.78	1.0	

Demo Board MCL P/N: TB-613+ Suggested PCB Layout (PL-343)

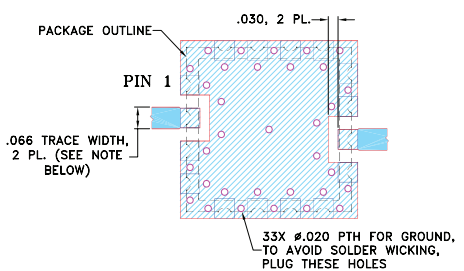

NOTES: 1. TRACE WIDTH IS SHOWN FOR ROGERS RO4350B WITH DIELECTRIC THICKNESS .030" ± .002"; COPPER: 1/2 OZ. EACH SIDE. FOR OTHER MATERIALS TRACE WIDTH MAY NEED TO BE MODIFIED.
2. BOTTOM SIDE OF THE PCB IS CONTINUOUS GROUND PLANE.

DENOTES PCB COPPER LAYOUT WITH SMOBC (SOLDER MASK OVER BARE COPPER)
 DENOTES COPPER LAND PATTERN FREE OF SOLDER MASK

Notes

- Performance and quality attributes and conditions not expressly stated in this specification document are intended to be excluded and do not form a part of this specification document.
- Electrical specifications and performance data contained in this specification document are based on Mini-Circuit's applicable established test performance criteria and measurement instructions.
- The parts covered by this specification document are subject to Mini-Circuits standard limited warranty and terms and conditions (collectively, "Standard Terms"); Purchasers of this part are entitled to the rights and benefits contained therein. For a full statement of the Standard Terms and the exclusive rights and remedies thereunder, please visit Mini-Circuits' website at www.minicircuits.com/MCLStore/terms.jsp

Features

- low insertion loss, 0.7 dB typ.
- very low output power 0 dBm typ. at 30 dBm input
- low cost
- aqueous washable

Applications

- military, hi-rel applications
- stabilizing generator outputs
- reducing amplitude variations
- protects low noise amplifiers and other devices from ESD or input power damage

Electrical Specifications

Parameter	Condition	Min.	Typ.	Max.	Units
Frequency Range		950		2050	MHz
Linear Range					
Max Input Power	less than 0.1 dB compression	—	—	-10	dBm
Insertion Loss	less than -10 dBm input power	—	0.7	1.3	dB
VSWR	less than -10 dBm input power	—	1.35	1.6	:1
Limiting Range					
Input Power	>1dB compression filtered signal frequency	+5	—	+30	dBm
Output Power		—	0	—	dBm
Δ Output/ Δ 1dB Input	Input Power Range (dBm)				
	5 to 10	—	0.1	—	dB/dB
	10 to 20	—	0.05	—	
	20 to 30	—	0.1	—	
Recovery Time	1 watt pulse 50 μsec PW 1kHz duty cycle recovery to within 90% of final value.	—	8	—	nsec
Response Time	-30 to +30 dBm input 50 μsec PW 1 kHz duty cycle	—	2	—	nsec

Typical Performance Data

Freq. (MHz)	I. Loss (dB) in Linear Range	VSWR (:1) in Linear Range	Power Output (dBm)				Δ Output / Δ 1dB Input			
			at -10 dBm Input	+5 dBm Input	+10 dBm Input	+20 dBm Input	+30 dBm Input	+5 to +10 dBm Input	+10 to +20 dBm Input	+20 to +30 dBm Input
950.00	0.50	1.35	-0.03	0.33	0.58	-0.68	0.07	0.03	-0.13	
1060.00	0.51	1.34	-0.12	0.41	0.64	-0.59	0.11	0.02	-0.12	
1115.00	0.51	1.33	-0.56	0.11	0.33	0.24	0.13	0.02	-0.01	
1170.00	0.53	1.32	-0.34	0.18	0.38	-0.87	0.10	0.02	-0.13	
1280.00	0.54	1.28	-0.37	-0.06	-0.05	-0.79	0.06	0.00	-0.07	
1390.00	0.54	1.25	-0.41	-0.19	-0.20	-0.50	0.04	0.00	-0.03	
1445.00	0.54	1.23	-0.85	-0.26	-0.41	-0.69	0.12	-0.02	-0.03	
1500.00	0.55	1.21	-0.72	-0.56	-0.66	-1.04	0.03	-0.01	-0.04	
1555.00	0.55	1.20	-1.10	-0.45	-0.68	-1.20	0.13	-0.02	-0.05	
1665.00	0.56	1.18	-1.23	-0.71	-0.99	-1.42	0.10	-0.03	-0.04	
1720.00	0.57	1.18	-1.18	-1.08	-1.26	-1.48	0.02	-0.02	-0.02	
1830.00	0.61	1.19	-1.47	-1.37	-1.48	-1.84	0.02	-0.01	-0.04	
1940.00	0.64	1.22	-1.72	-1.52	-1.71	-2.03	0.04	-0.02	-0.03	
1995.00	0.67	1.24	-1.86	-1.72	-1.90	-2.60	0.03	-0.02	-0.07	
2050.00	0.68	1.26	-2.08	-2.19	-2.36	-3.24	-0.02	-0.02	-0.09	

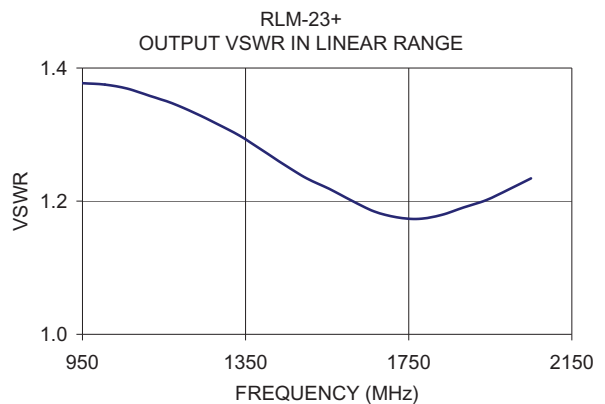
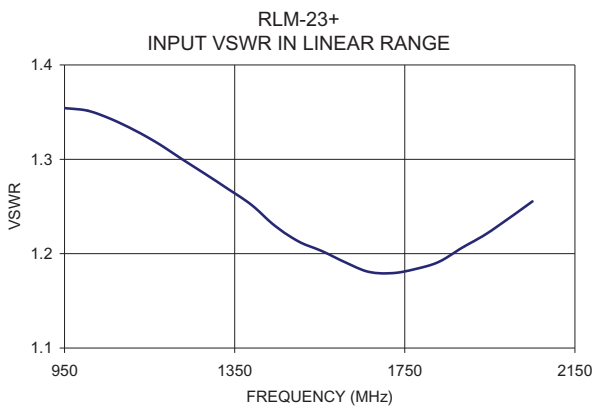
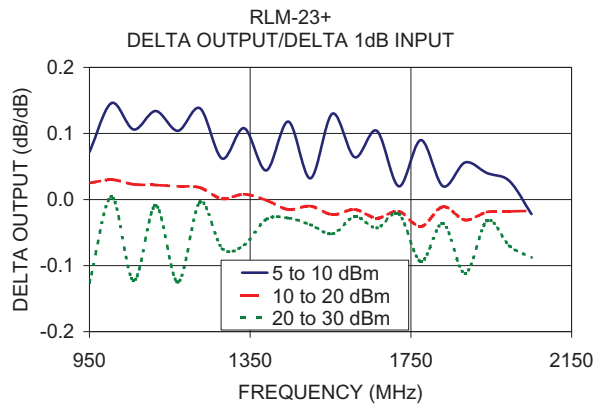
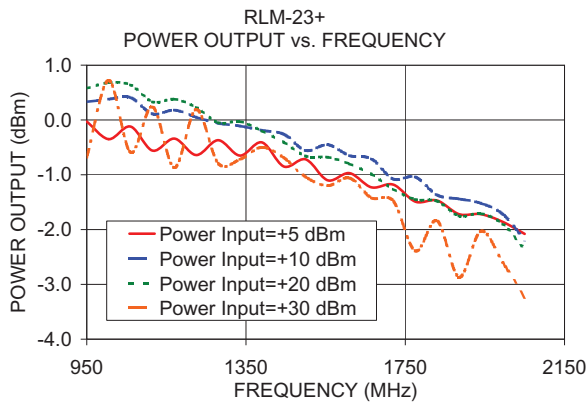
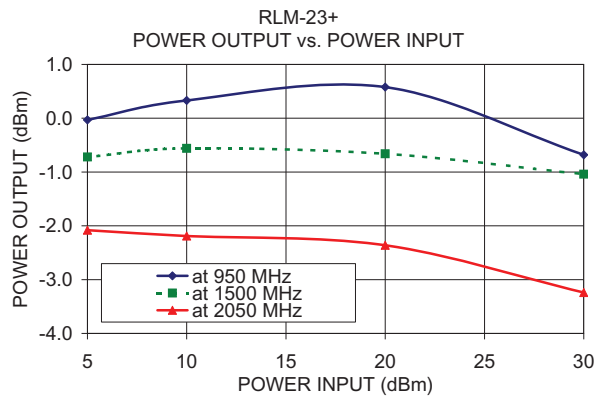
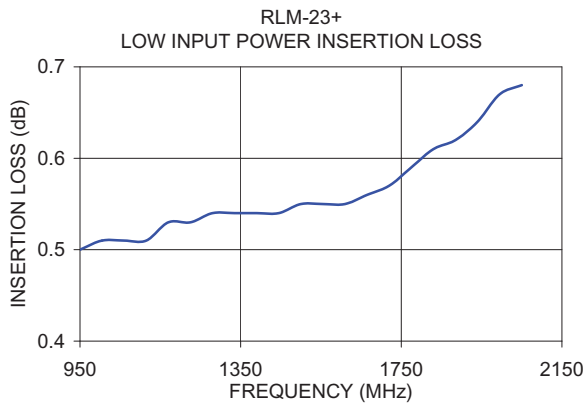

Notes

- A. Performance and quality attributes and conditions not expressly stated in this specification document are intended to be excluded and do not form a part of this specification document.
- B. Electrical specifications and performance data contained in this specification document are based on Mini-Circuit's applicable established test performance criteria and measurement instructions.
- C. The parts covered by this specification document are subject to Mini-Circuits standard limited warranty and terms and conditions (collectively, "Standard Terms"); Purchasers of this part are entitled to the rights and benefits contained therein. For a full statement of the Standard Terms and the exclusive rights and remedies thereunder, please visit Mini-Circuits' website at www.minicircuits.com/MCLStore/terms.jsp



Typical Performance Data

FREQUENCY (MHz)	LOW INPUT POWER			POWER OUTPUT (dBm)				DELTA OUTPUT/1dB DELTA INPUT (dB/dB)		
	INSERTION LOSS (dB)	VSWR		+5 dBm INPUT	+10 dBm INPUT	+20 dBm INPUT	+30 dBm INPUT	+5 to +10 dBm INPUT	+10 to +20 dBm INPUT	+20 to +30 dBm INPUT
		Input	Output							
		(:1)								
950.0	0.50	1.35	1.38	-0.03	0.33	0.58	-0.68	0.07	0.03	-0.13
1005.0	0.51	1.35	1.38	-0.35	0.38	0.68	0.72	0.15	0.03	0.00
1060.0	0.51	1.34	1.37	-0.12	0.41	0.64	-0.59	0.11	0.02	-0.12
1115.0	0.51	1.33	1.36	-0.56	0.11	0.33	0.24	0.13	0.02	-0.01
1170.0	0.53	1.32	1.35	-0.34	0.18	0.38	-0.87	0.10	0.02	-0.13
1225.0	0.53	1.30	1.33	-0.64	0.05	0.23	0.19	0.14	0.02	0.00
1280.0	0.54	1.28	1.32	-0.37	-0.06	-0.05	-0.79	0.06	0.00	-0.07
1335.0	0.54	1.27	1.30	-0.65	-0.11	-0.03	-0.72	0.11	0.01	-0.07
1390.0	0.54	1.25	1.28	-0.41	-0.19	-0.20	-0.50	0.04	0.00	-0.03
1445.0	0.54	1.23	1.25	-0.85	-0.26	-0.41	-0.69	0.12	-0.02	-0.03
1500.0	0.55	1.21	1.23	-0.72	-0.56	-0.66	-1.04	0.03	-0.01	-0.04
1555.0	0.55	1.20	1.22	-1.10	-0.45	-0.68	-1.20	0.13	-0.02	-0.05
1610.0	0.55	1.19	1.20	-0.97	-0.65	-0.80	-1.06	0.06	-0.02	-0.03
1665.0	0.56	1.18	1.18	-1.23	-0.71	-0.99	-1.42	0.10	-0.03	-0.04
1720.0	0.57	1.18	1.18	-1.18	-1.08	-1.26	-1.48	0.02	-0.02	-0.02
1775.0	0.59	1.18	1.17	-1.49	-1.04	-1.45	-2.39	0.09	-0.04	-0.09
1830.0	0.61	1.19	1.18	-1.47	-1.37	-1.48	-1.84	0.02	-0.01	-0.04
1885.0	0.62	1.21	1.19	-1.72	-1.44	-1.75	-2.87	0.06	-0.03	-0.11
1940.0	0.64	1.22	1.20	-1.72	-1.52	-1.71	-2.03	0.04	-0.02	-0.03
1995.0	0.67	1.24	1.22	-1.86	-1.72	-1.90	-2.60	0.03	-0.02	-0.07
2050.0	0.68	1.26	1.23	-2.08	-2.19	-2.36	-3.24	-0.02	-0.02	-0.09

Typical Performance Data

POWER INPUT	POWER OUTPUT	POWER INPUT	POWER OUTPUT	POWER INPUT	POWER OUTPUT
@ 950 MHz		@ 1500 MHz		@ 2050 MHz	
(dBm)		(dBm)		(dBm)	
5	-0.03	5	-0.72	5	-2.08
10	0.33	10	-0.56	10	-2.19
20	0.58	20	-0.66	20	-2.36
30	-0.68	30	-1.04	30	-3.24

Typical Performance Curves

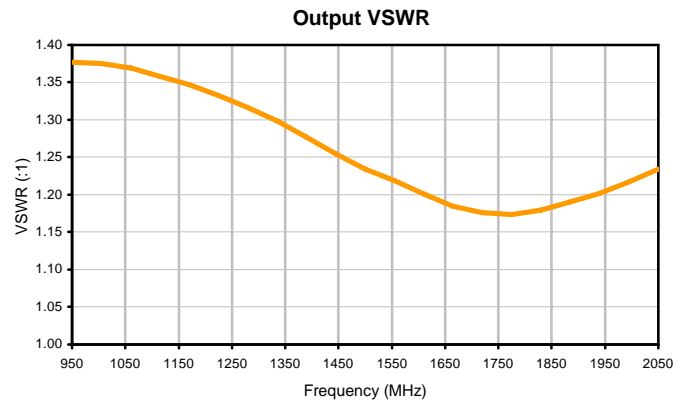
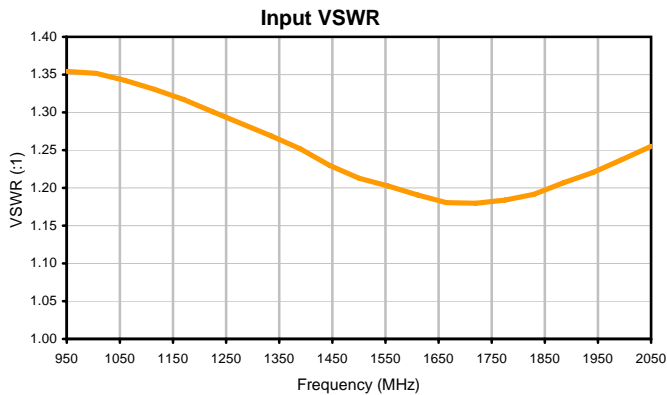
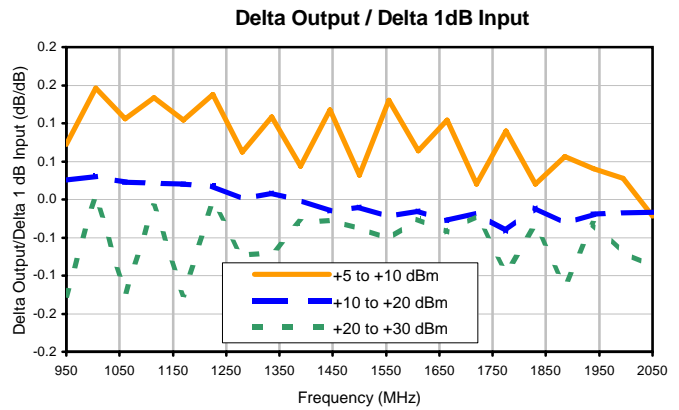
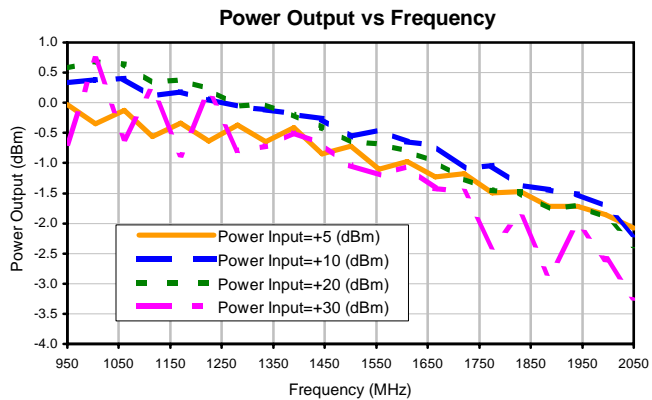
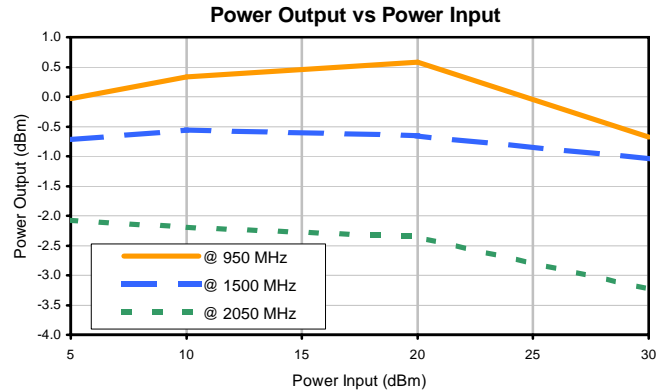
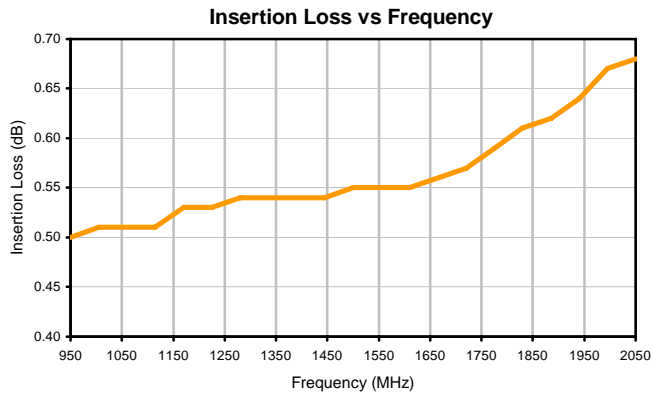

Outline Dimensions

CK1246-1

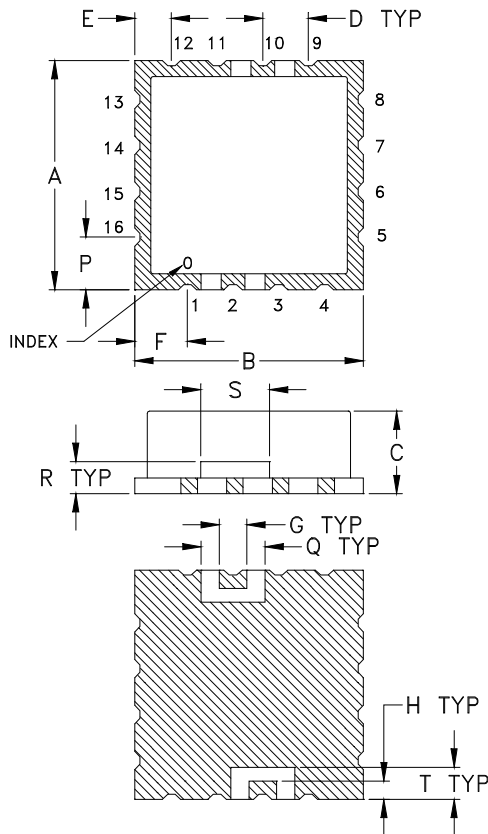

PCB Land Pattern

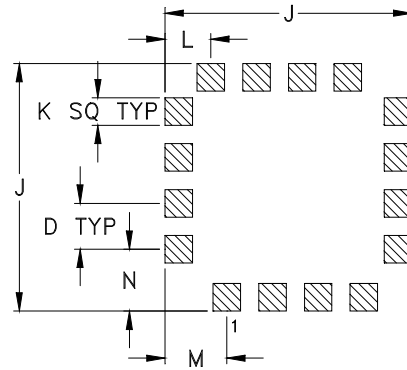

Suggested Layout,
Tolerance to be within $\pm .002$

CASE #	A	B	C	D	E	F	G	H	J	K
CK1246-1	.500 (12.70)	.500 (12.70)	.180 (4.57)	.100 (2.54)	.080 (2.03)	.115 (2.92)	.060 (1.52)	.040 (1.02)	.540 (13.72)	.060 (1.52)
CASE #	L	M	N	P	Q	R	S	T	WT. GRAM	
CK1246-1	.100 (2.54)	.135 (3.43)	.135 (3.43)	.115 (2.92)	.140 (3.56)	.070 (1.78)	.150 (3.81)	.070 (1.78)	1.0	

Dimensions are in inches (mm). Tolerances: 2 Pl. $\pm .03$; 3Pl. $\pm .015$

Notes:

- Case material: Nickel-Silver alloy.
- Base: Printed wiring laminate.
- Termination finish:
For RoHS Case Styles: 3-5 μ inch (.08-.13 microns) Gold over 120-240 μ inch (3.05-6.10 microns) Nickel plate.
All models, (+) suffix.

Mini-Circuits
ISO 9001 ISO 14001 CERTIFIED

ALL NEW
minicircuits.com

P.O. Box 350166, Brooklyn, New York 11235-0003 (718) 934-4500 Fax (718) 332-4661 For detailed performance specs & shopping online see Mini-Circuits web site



The Design Engineers Search Engine Provides ACTUAL Data Instantly From MINI-CIRCUITS At: www.minicircuits.com

RF/IF MICROWAVE COMPONENTS

Tape & Reel Packaging TR-F37

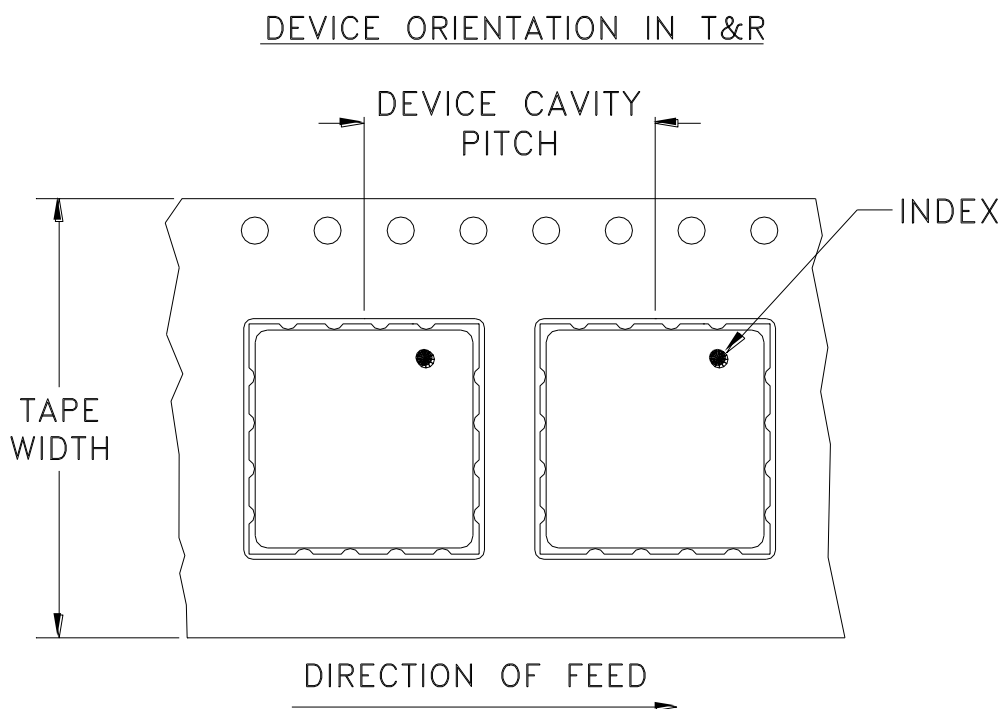

Tape Width, mm	Device Cavity Pitch, mm	Reel Size, inches	Devices per Reel	
24	16	7	Small quantity standards (see note)	10
				20
				50
				100
		13	Standard	200
500				

Note: Please consult individual model data sheet to determine device per reel availability.

Mini-Circuits carrier tape materials provide protection from ESD (Electro-Static Discharge) during handling and transportation. Tapes are static dissipative and comply with industry standards EIA-481/EIA-541.

Go to: www.minicircuits.com/pages/pdfs/tape.pdf



INTERNET <http://www.minicircuits.com>

P.O. Box 350166, Brooklyn, New York 11235-0003 (718) 934-4500 Fax (718) 332-4661

Distribution Centers NORTH AMERICA 800-654-7949 • 417-335-5935 • Fax 417-335-5945 • EUROPE 44-1252-832600 • Fax 44-1252-837010

Mini-Circuits ISO 9001 & ISO 14001 Certified

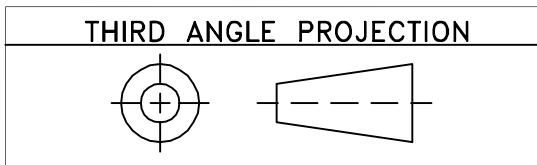

REVISIONS					
REV	ECN No.	DESCRIPTION	DATE	DR	AUTH
OR	M131034	NEW RELEASE	03/16/11	PW	DJ

SUGGESTED MOUNTING CONFIGURATION FOR
CK1246-1 CASE STYLE, "16LM01" PIN CONNECTION

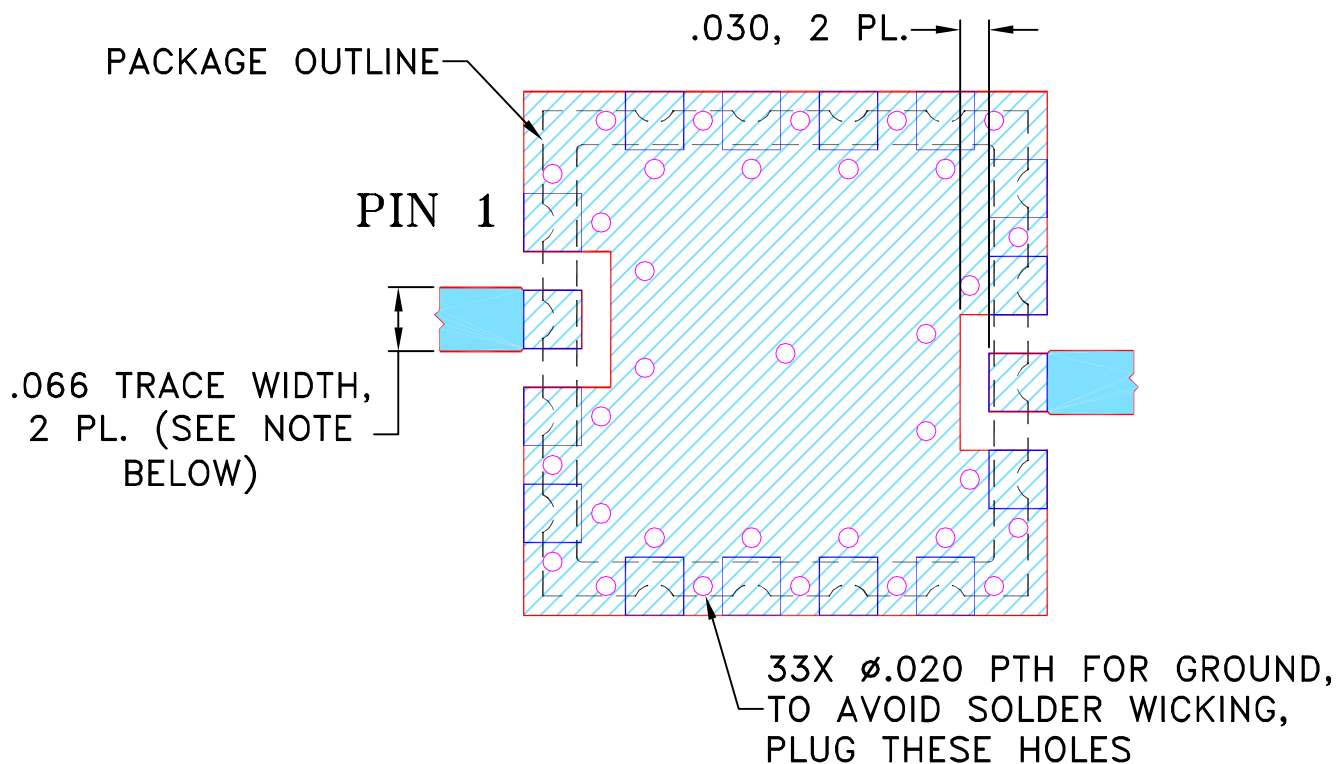

- NOTES: 1. TRACE WIDTH IS SHOWN FOR ROGERS RO4350B WITH DIELECTRIC THICKNESS .030" \pm .002"; COPPER: 1/2 OZ. EACH SIDE. FOR OTHER MATERIALS TRACE WIDTH MAY NEED TO BE MODIFIED.
2. BOTTOM SIDE OF THE PCB IS CONTINUOUS GROUND PLANE.



DENOTES PCB COPPER LAYOUT WITH SMOBC (SOLDER MASK OVER BARE COPPER)



DENOTES COPPER LAND PATTERN FREE OF SOLDER MASK

UNLESS OTHERWISE SPECIFIED	INITIALS	DATE
DIMENSIONS ARE IN INCHES	DRAWN PW	03/10/11
TOLERANCES ON:	CHECKED IL	03/16/11
2 PL DECIMALS \pm	APPROVED DJ	03/16/11
3 PL DECIMALS \pm .005		
ANGLES \pm		
FRACTIONS \pm		



Mini-Circuits®

13 Neptune Avenue
Brooklyn NY 11235

PL, 16LM01, CK1246-1, TB-613+

Mini-Circuits®
THIS DOCUMENT AND ITS CONTENTS ARE THE PROPERTY OF MINI-CIRCUITS. EXCEPT FOR USE EXPRESSLY GRANTED, IN WRITING, TO ITS VENDORS, VENDEE AND THE UNITED STATES GOVERNMENT, MINI-CIRCUITS RESERVES ALL PROPRIETARY DESIGN, USE, MANUFACTURING AND REPRODUCTION RIGHTS THERETO. THESE CONTENTS SHALL NOT BE USED, DUPLICATED OR DISCLOSED TO ANY OUTSIDE PARTY, IN WHOLE OR IN PART, WITHOUT WRITTEN PERMISSION OF MINI-CIRCUITS.

ASHEETA1.DWG REV:A DATE:01/12/95

SIZE	CODE IDENT	DRAWING NO:	REV:
A	15542	98-PL-343	OR
FILE:	98PL343	SCALE: 5:1	SHEET: 1 OF 1

Evaluation Board and Circuit

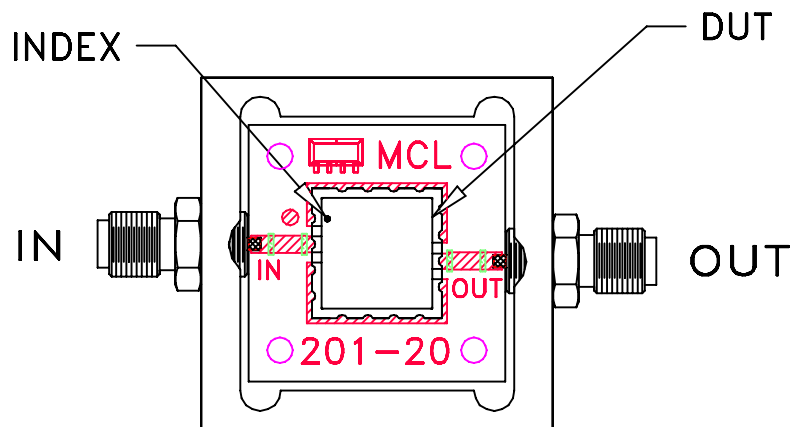

TB-613+

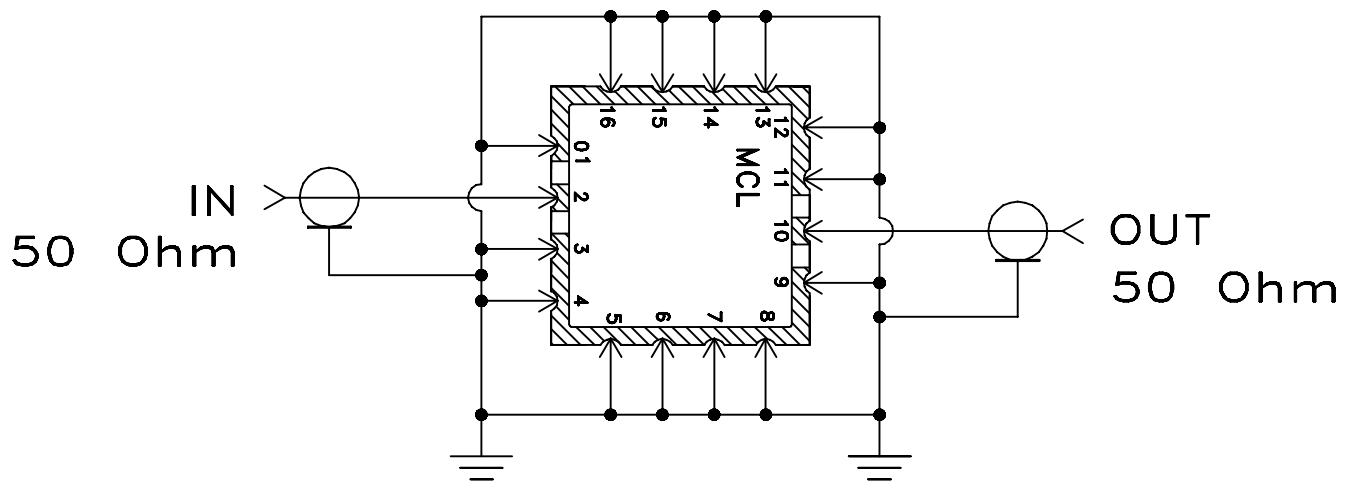

Schematic Diagram

Notes:

1. 50 Ohm SMA Female connectors.
2. PCB Material: Rogers R04350 or equivalent,
Dielectric Constant=3.5, Thickness=.030 inch.

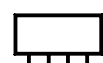
 Mini-Circuits®

All Mini-Circuits products are manufactured under exacting quality assurance and control standards, and are capable of meeting published specifications after being subjected to any or all of the following physical and environmental test.

Specification	Test/Inspection Condition	Reference/Spec
Operating Temperature	-40° to 85° C Ambient Environment	Individual Model Data Sheet
Storage Temperature	-55° to 100° C Ambient Environment	Individual Model Data Sheet
HAST	130°C, 85% RH, 96 hours	JESD22-A110
Humidity	90 to 95% RH, 240 hours, 50°C	MIL-STD-202, Method 103, Condition A, Except 50°C and end-point electrical test done within 12 hours
Thermal Shock	-55° to 100°C, 100 cycles	MIL-STD-202, Method 107, Condition A-3, except +100°C
Solder Reflow Heat	Sn-Pb Eutectic Process: 225°C peak Pb-Free Process, 245°C peak	J-STD-020, Table 4-1, 4-2 and 5-2, Figure 5-1
Solderability	10X Magnification	J-STD-002, Para 4.2.5, Test S, 95% Coverage
Vibration (High Frequency)	20g peak, 20-2000 Hz, 4 times in each of three axes (total 12)	MIL-STD-883, Method 2007.3, Condition A
Mechanical Shock	50g, 11 ms, 1/2-sine, 18 shocks: 3 each direction, each of 3 axes	MIL-STD-202, Method 213, Condition A
Marking Resistance to Solvents	Isopropyl alcohol + mineral spirits at 25°C; terpene defluxer at 25°C; distilled water + proylene glycol monomethyl ether + monoethanolamine at 63°C to 70°C	MIL-STD-202, Method 215