

# Surface Mount Power Splitter/Combiner

## RPQ-820

2 Way-90° 50Ω 760 to 860 MHz



Generic photo used for illustration purposes only

CASE STYLE: TT240

### Maximum Ratings

Operating Temperature	-40°C to 85°C
Storage Temperature	-55°C to 100°C
Power Input (as a splitter)	1W max.

Permanent damage may occur if any of these limits are exceeded.

### Pin Connections

SUM PORT	4
PORT 1 (0°)	1
PORT 2 (+90°)	3
GROUND	2,5
50 OHM TERM EXTERNAL	6

### Outline Drawing

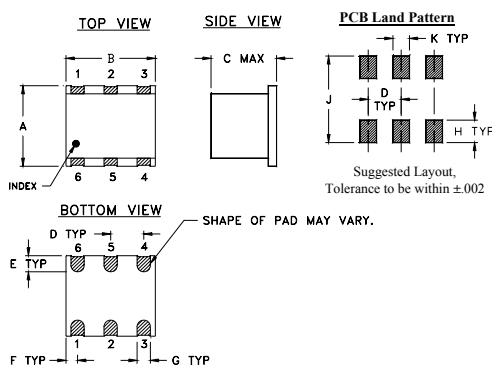

### Outline Dimensions (inch/mm)

A	B	C	D	E	F
.250	.31	.20	.100	.050	.055
6.35	7.87	5.08	2.54	1.27	1.40
G	H	J	K	wt	
.040	.070	.270	.050	grams	
1.02	1.78	6.86	1.27	0.50	

### Demo Board MCL P/N: TB-210 Suggested PCB Layout (PL-111)

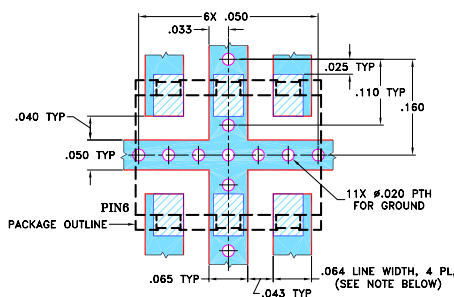

- NOTES: 1. TRACE WIDTH IS SHOWN FOR ROGERS RO4350B WITH DIELECTRIC THICKNESS 0.030" ± 0.002"; COPPER: 1/2 OZ. EACH SIDE. FOR OTHER MATERIALS TRACE WIDTH MAY NEED TO BE MODIFIED.  
2. BOTTOM SIDE OF THE PCB IS CONTINUOUS GROUND PLANE.  
■ DENOTES PCB COPPER LAYOUT WITH SMOBC (SOLDER MASK OVER BARE COPPER)  
■ DENOTES COPPER LAND PATTERN FREE OF SOLDER MASK

#### Notes

- A. Performance and quality attributes and conditions not expressly stated in this specification document are intended to be excluded and do not form a part of this specification document.  
B. Electrical specifications and performance data contained in this specification document are based on Mini-Circuit's applicable established test performance criteria and measurement instructions.  
C. The parts covered by this specification document are subject to Mini-Circuit's standard limited warranty and terms and conditions (collectively, "Standard Terms"); Purchasers of this part are entitled to the rights and benefits contained therein. For a full statement of the Standard Terms and the exclusive rights and remedies thereunder, please visit Mini-Circuit's website at [www.minicircuits.com/MCLStore/terms.jsp](http://www.minicircuits.com/MCLStore/terms.jsp)

### Features

- low insertion loss, 0.15 dB typ.
- good isolation, 22 dB typ.

### Applications

- UHF
- modulators
- image rejection mixers

### Electrical Specifications

FREQ. RANGE (MHz)	ISOLATION (dB)	INSERTION LOSS (dB) Avg. of Coupled Outputs ABOVE 3 dB	PHASE UNBALANCE (Degrees)	AMPLITUDE UNBALANCE (dB)
$f_L$ - $f_U$	Typ. Min.	Typ. Max.	Max.	Max.
760-860	22 15	0.15 0.7	4	1

### Typical Performance Data

Frequency (MHz)	Total Loss <sup>1</sup> (dB)		Amplitude Unbalance (dB)	Isolation (dB)	Phase Unbalance (deg.)	VSWR S	VSWR 1	VSWR 2
	S-1	S-2						
760.00	2.76	3.58	0.82	33.02	90.78	1.072	1.094	1.061
765.00	2.78	3.55	0.76	32.97	90.77	1.073	1.094	1.061
770.00	2.81	3.52	0.71	32.88	90.78	1.073	1.094	1.061
777.50	2.85	3.47	0.62	32.78	90.80	1.074	1.095	1.062
785.00	2.89	3.43	0.54	32.69	90.84	1.074	1.095	1.063
792.50	2.93	3.39	0.46	32.57	90.84	1.075	1.095	1.064
800.00	2.97	3.35	0.38	32.43	90.84	1.076	1.096	1.065
807.50	3.00	3.31	0.31	32.32	90.85	1.077	1.097	1.065
815.00	3.04	3.27	0.22	32.18	90.88	1.078	1.097	1.066
822.50	3.08	3.23	0.15	32.03	90.88	1.079	1.098	1.068
830.00	3.12	3.19	0.08	31.88	90.88	1.080	1.098	1.069
840.00	3.17	3.14	0.03	31.66	90.90	1.082	1.099	1.070
850.00	3.22	3.09	0.13	31.43	90.91	1.083	1.100	1.071
855.00	3.25	3.07	0.18	31.32	90.90	1.084	1.100	1.071
860.00	3.27	3.05	0.23	31.20	90.92	1.085	1.100	1.072

1. Total Loss = Insertion Loss + 3dB splitter loss.

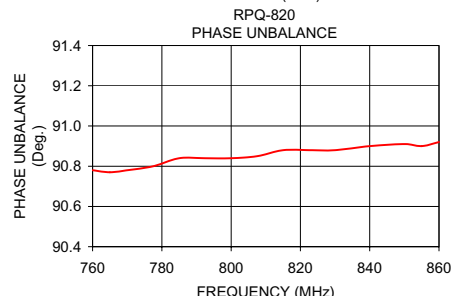
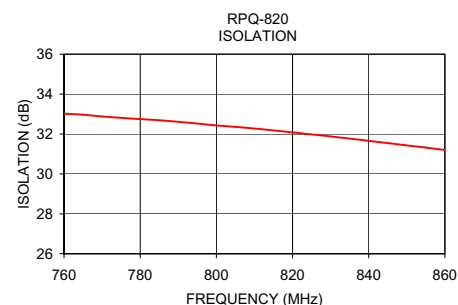
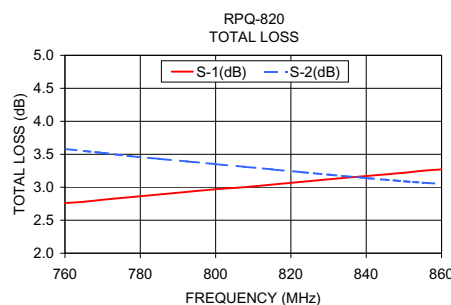

### electrical schematic

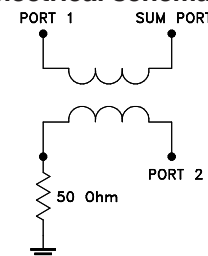

# 2 Way-90° Power Splitter/Combiner

# RPQ-820

## Typical Performance Data

TEST CONDITIONS: INPUT POWER = 0dBm @Temperature = +25°C

FREQ. (MHz)	TOTAL LOSS <sup>1</sup> (dB)		AMP. UNBAL. (dB)	PHASE UNBAL. From 90° (deg.)	ISOLATION (dB) 1-2	VSWR (:1)		
	S-1	S-2				S	1	2
300	0.72	9.09	8.37	0.45	28.47	1.03	1.02	1.03
350	0.93	7.97	7.05	0.44	27.48	1.04	1.03	1.03
400	1.15	7.05	5.90	0.44	26.73	1.05	1.03	1.04
450	1.38	6.27	4.89	0.43	26.18	1.06	1.04	1.04
500	1.63	5.61	3.98	0.40	25.77	1.07	1.05	1.05
550	1.88	5.05	3.17	0.40	25.49	1.08	1.06	1.06
600	2.15	4.57	2.41	0.39	25.28	1.09	1.07	1.06
650	2.41	4.15	1.74	0.37	25.20	1.10	1.08	1.07
700	2.69	3.79	1.10	0.34	25.18	1.11	1.09	1.07
710	2.75	3.72	0.98	0.31	25.19	1.11	1.09	1.08
720	2.80	3.66	0.86	0.31	25.19	1.11	1.09	1.08
730	2.85	3.60	0.74	0.33	25.20	1.11	1.09	1.08
740	2.90	3.54	0.63	0.32	25.21	1.11	1.09	1.08
750	2.95	3.48	0.53	0.29	25.23	1.11	1.10	1.08
760	3.01	3.42	0.40	0.28	25.26	1.11	1.10	1.08
770	3.07	3.37	0.30	0.28	25.26	1.12	1.10	1.08
780	3.12	3.31	0.19	0.27	25.29	1.12	1.10	1.09
790	3.18	3.25	0.07	0.25	25.30	1.12	1.10	1.09
800	3.23	3.20	0.03	0.24	25.30	1.12	1.11	1.09
810	3.29	3.15	0.13	0.24	25.30	1.12	1.11	1.09
820	3.34	3.10	0.24	0.22	25.33	1.12	1.11	1.09
830	3.39	3.06	0.34	0.21	25.36	1.12	1.11	1.09
840	3.45	3.01	0.44	0.19	25.42	1.12	1.11	1.09
850	3.51	2.96	0.55	0.20	25.45	1.13	1.11	1.10
860	3.56	2.91	0.65	0.21	25.44	1.13	1.11	1.10
870	3.61	2.87	0.75	0.22	25.45	1.13	1.12	1.10
880	3.67	2.82	0.84	0.21	25.46	1.13	1.12	1.10
890	3.72	2.78	0.94	0.19	25.49	1.13	1.12	1.10
900	3.77	2.74	1.03	0.19	25.50	1.13	1.12	1.10
950	4.03	2.55	1.48	0.09	25.62	1.14	1.13	1.11
1000	4.30	2.39	1.91	0.04	25.57	1.14	1.13	1.12
1050	4.55	2.24	2.32	0.02	25.54	1.14	1.14	1.12
1100	4.81	2.11	2.70	0.08	25.46	1.15	1.15	1.13
1150	5.09	1.99	3.10	0.19	25.47	1.15	1.15	1.13
1200	5.32	1.88	3.44	0.17	25.03	1.15	1.16	1.14
1300	5.79	1.70	4.10	0.30	24.21	1.16	1.17	1.15
1400	6.25	1.55	4.70	0.44	23.07	1.16	1.18	1.16
1500	6.69	1.45	5.24	0.62	21.97	1.17	1.19	1.18
1600	7.08	1.35	5.72	0.76	20.76	1.18	1.19	1.19
1700	7.47	1.29	6.18	1.03	19.77	1.19	1.20	1.20
1800	7.85	1.23	6.62	1.29	18.90	1.20	1.21	1.21
1900	8.16	1.22	6.94	1.76	17.87	1.22	1.22	1.23
2000	8.49	1.18	7.31	2.17	17.12	1.23	1.24	1.25
2100	8.77	1.16	7.61	2.77	16.43	1.25	1.26	1.27
2200	9.06	1.16	7.90	3.47	15.84	1.28	1.28	1.29
2300	9.32	1.17	8.15	4.24	15.28	1.30	1.32	1.31
2400	9.55	1.17	8.38	5.17	14.76	1.33	1.35	1.34
2500	9.77	1.19	8.58	6.20	14.30	1.35	1.39	1.36

<sup>1</sup> Total Loss = Insertion Loss+ 3dB Splitter Loss

REV. X2  
RPQ-820  
100627  
Page 1 of 3



RF/MICROWAVE COMPONENTS • ISO 9001 ISO 14001 AS 9100 CERTIFIED • RoHS compliant  
P.O. Box 350166, Brooklyn, New York 11235-0006 (718) 934-4500 Fax (718) 332-4661



The Design Engineers Search Engine finds the model you need, Instantly • For detailed performance specs & shopping online see



# 2 Way-90° Power Splitter/Combiner

# RPQ-820

## Typical Performance Data

TEST CONDITIONS: INPUT POWER = 0dBm @Temperature = -40°C

FREQ. (MHz)	TOTAL LOSS <sup>1</sup> (dB)		AMP. UNBAL. (dB)	PHASE UNBAL. From 90° (deg.)	ISOLATION (dB) 1-2	VSWR (:1)		
	S-1	S-2				S	1	2
300	0.65	9.14	8.49	0.26	29.03	1.03	1.01	1.03
350	0.85	8.00	7.16	0.26	27.94	1.03	1.02	1.03
400	1.06	7.07	6.01	0.26	27.13	1.05	1.03	1.04
450	1.28	6.27	4.99	0.24	26.52	1.06	1.04	1.04
500	1.52	5.61	4.09	0.24	26.02	1.07	1.05	1.05
550	1.78	5.05	3.27	0.21	25.65	1.08	1.06	1.06
600	2.03	4.55	2.51	0.23	25.35	1.09	1.07	1.07
650	2.29	4.12	1.83	0.20	25.23	1.10	1.08	1.07
700	2.56	3.76	1.19	0.17	25.16	1.11	1.09	1.08
710	2.61	3.69	1.08	0.17	25.16	1.11	1.09	1.08
720	2.66	3.63	0.97	0.15	25.14	1.11	1.09	1.08
730	2.71	3.56	0.85	0.17	25.12	1.11	1.09	1.08
740	2.77	3.50	0.73	0.17	25.12	1.12	1.09	1.08
750	2.82	3.44	0.62	0.14	25.15	1.12	1.09	1.09
760	2.88	3.38	0.50	0.14	25.17	1.12	1.10	1.09
770	2.93	3.32	0.39	0.13	25.15	1.12	1.10	1.09
780	2.98	3.27	0.28	0.13	25.16	1.12	1.10	1.09
790	3.04	3.21	0.17	0.11	25.16	1.12	1.10	1.09
800	3.09	3.16	0.06	0.09	25.15	1.13	1.10	1.09
810	3.14	3.09	0.04	0.09	25.14	1.13	1.11	1.10
820	3.20	3.05	0.15	0.08	25.17	1.13	1.11	1.10
830	3.25	3.01	0.25	0.08	25.19	1.13	1.11	1.10
840	3.30	2.95	0.35	0.05	25.24	1.13	1.11	1.10
850	3.36	2.90	0.46	0.06	25.26	1.13	1.11	1.10
860	3.41	2.86	0.55	0.08	25.23	1.13	1.11	1.10
870	3.46	2.82	0.65	0.08	25.24	1.13	1.11	1.10
880	3.52	2.77	0.74	0.07	25.25	1.13	1.11	1.10
890	3.57	2.72	0.85	0.07	25.27	1.13	1.12	1.11
900	3.62	2.68	0.94	0.04	25.27	1.14	1.12	1.11
950	3.88	2.48	1.40	0.04	25.39	1.14	1.13	1.12
1000	4.14	2.32	1.82	0.06	25.30	1.15	1.14	1.12
1050	4.39	2.17	2.23	0.12	25.23	1.15	1.14	1.13
1100	4.64	2.03	2.62	0.22	25.12	1.15	1.15	1.14
1150	4.92	1.90	3.02	0.29	25.16	1.15	1.15	1.14
1200	5.15	1.78	3.36	0.28	24.73	1.16	1.16	1.15
1300	5.61	1.60	4.02	0.39	23.90	1.17	1.17	1.16
1400	6.06	1.44	4.62	0.50	22.73	1.17	1.18	1.17
1500	6.48	1.32	5.16	0.59	21.67	1.17	1.19	1.18
1600	6.88	1.22	5.65	0.76	20.59	1.17	1.18	1.19
1700	7.27	1.15	6.12	1.06	19.59	1.18	1.20	1.20
1800	7.66	1.08	6.58	1.40	18.68	1.19	1.21	1.20
1900	7.94	1.06	6.88	1.71	17.60	1.21	1.23	1.23
2000	8.26	1.02	7.24	2.17	16.87	1.23	1.24	1.25
2100	8.56	0.99	7.56	2.69	16.14	1.25	1.26	1.25
2200	8.83	0.98	7.85	3.33	15.54	1.27	1.29	1.28
2300	9.08	0.99	8.09	4.16	15.03	1.30	1.33	1.32
2400	9.30	0.98	8.32	4.83	14.52	1.31	1.34	1.33
2500	9.55	0.99	8.55	6.06	14.08	1.34	1.43	1.36

<sup>1</sup> Total Loss = Insertion Loss+ 3dB Splitter Loss



# 2 Way-90° Power Splitter/Combiner

# RPQ-820

## Typical Performance Data

TEST CONDITIONS: INPUT POWER = 0dBm @Temperature = +85°C

FREQ. (MHz)	TOTAL LOSS <sup>1</sup> (dB)		AMP. UNBAL. (dB)	PHASE UNBAL. From 90° (deg.)	ISOLATION (dB) 1-2	VSWR (:1)		
	S-1	S-2				S	1	2
300	0.75	9.08	8.33	0.58	28.24	1.03	1.02	1.03
350	0.97	7.97	7.00	0.57	27.33	1.04	1.03	1.04
400	1.19	7.05	5.86	0.59	26.63	1.05	1.04	1.04
450	1.43	6.27	4.84	0.56	26.11	1.06	1.05	1.04
500	1.68	5.62	3.94	0.55	25.74	1.07	1.06	1.05
550	1.94	5.07	3.13	0.52	25.50	1.08	1.06	1.05
600	2.20	4.59	2.38	0.49	25.32	1.09	1.07	1.06
650	2.47	4.18	1.71	0.47	25.29	1.10	1.08	1.06
700	2.74	3.82	1.07	0.44	25.31	1.10	1.09	1.07
710	2.81	3.75	0.95	0.41	25.34	1.10	1.09	1.07
720	2.86	3.69	0.83	0.40	25.35	1.11	1.09	1.07
730	2.91	3.63	0.72	0.41	25.35	1.11	1.10	1.07
740	2.96	3.57	0.60	0.41	25.36	1.11	1.10	1.07
750	3.02	3.51	0.49	0.38	25.39	1.11	1.10	1.08
760	3.07	3.45	0.38	0.37	25.43	1.11	1.10	1.08
770	3.13	3.40	0.27	0.38	25.44	1.11	1.10	1.08
780	3.18	3.35	0.16	0.35	25.46	1.11	1.11	1.08
790	3.24	3.29	0.05	0.33	25.48	1.12	1.11	1.08
800	3.29	3.24	0.06	0.31	25.49	1.12	1.11	1.08
810	3.35	3.18	0.16	0.31	25.48	1.12	1.11	1.08
820	3.40	3.14	0.26	0.29	25.51	1.12	1.11	1.08
830	3.46	3.10	0.37	0.26	25.54	1.12	1.11	1.09
840	3.52	3.04	0.47	0.24	25.60	1.12	1.11	1.09
850	3.57	3.00	0.58	0.25	25.65	1.12	1.12	1.09
860	3.63	2.95	0.68	0.26	25.64	1.12	1.12	1.09
870	3.68	2.91	0.78	0.27	25.65	1.12	1.12	1.09
880	3.74	2.86	0.87	0.26	25.66	1.13	1.12	1.09
890	3.79	2.82	0.97	0.26	25.69	1.13	1.12	1.09
900	3.84	2.78	1.06	0.24	25.69	1.13	1.12	1.10
950	4.10	2.59	1.51	0.16	25.76	1.13	1.13	1.10
1000	4.37	2.44	1.93	0.09	25.70	1.14	1.14	1.11
1050	4.63	2.29	2.34	0.06	25.64	1.14	1.15	1.12
1100	4.89	2.16	2.73	0.04	25.53	1.15	1.15	1.12
1150	5.17	2.04	3.12	0.10	25.51	1.15	1.16	1.13
1200	5.40	1.94	3.47	0.14	25.05	1.15	1.17	1.14
1300	5.88	1.76	4.13	0.27	24.13	1.16	1.18	1.15
1400	6.35	1.63	4.72	0.43	23.04	1.17	1.19	1.17
1500	6.78	1.52	5.26	0.57	21.92	1.18	1.19	1.19
1600	7.18	1.44	5.74	0.83	20.73	1.19	1.20	1.20
1700	7.58	1.37	6.21	1.07	19.77	1.20	1.20	1.22
1800	7.96	1.33	6.64	1.35	18.92	1.21	1.21	1.23
1900	8.28	1.31	6.97	2.02	17.95	1.23	1.23	1.25
2000	8.62	1.27	7.35	2.31	17.25	1.25	1.24	1.26
2100	8.91	1.26	7.65	2.92	16.59	1.26	1.26	1.28
2200	9.20	1.26	7.94	3.59	16.01	1.28	1.28	1.30
2300	9.47	1.27	8.20	4.35	15.45	1.31	1.31	1.31
2400	9.71	1.28	8.43	5.24	14.94	1.33	1.34	1.33
2500	9.93	1.29	8.64	6.19	14.49	1.35	1.37	1.35

<sup>1</sup> Total Loss = Insertion Loss+ 3dB Splitter Loss



# 2 Way-90° Power Splitter/Combiner

# RPQ-820

## Typical Performance Curves

### Total Loss

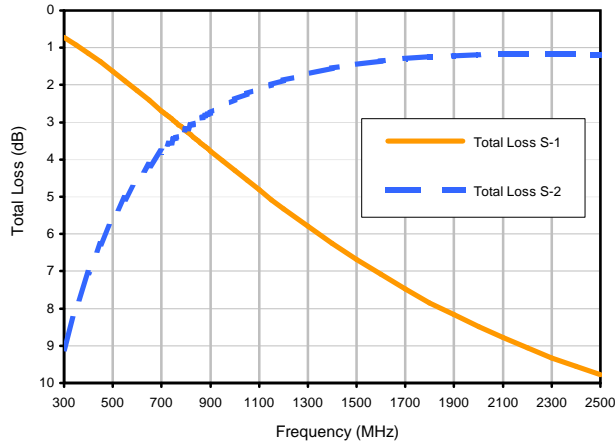

### Total Loss S-1 vs. TEMPERATURE

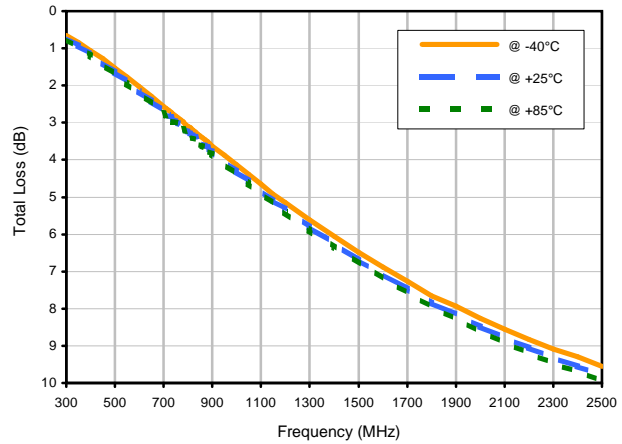

### Amplitude Unbalance vs. TEMPERATURE

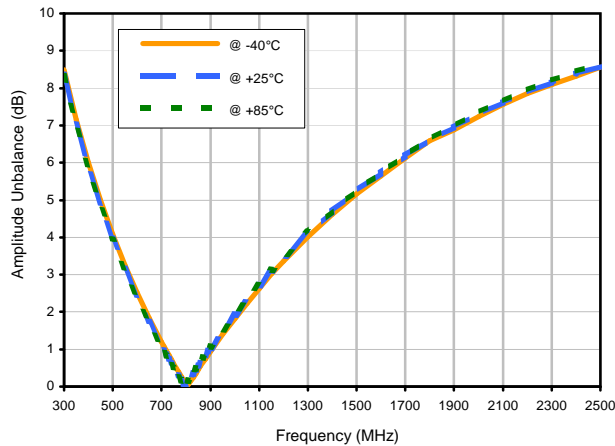

### Phase Unbalance vs. TEMPERATURE

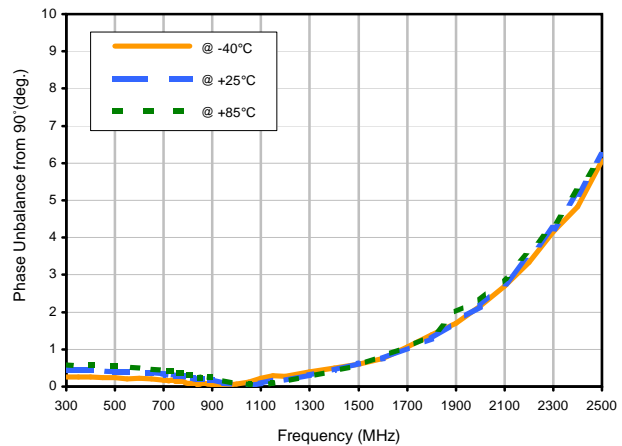

### Isolation 1-2 vs. TEMPERATURE

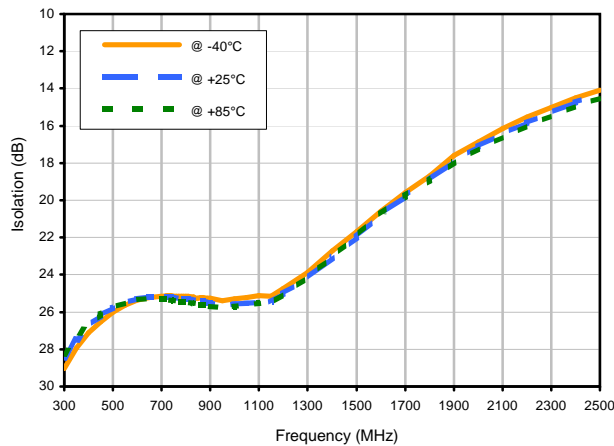

REV. X2  
RPQ-820  
100627  
Page 1 of 2



**Mini-Circuits**

RF/MICROWAVE COMPONENTS • ISO 9001 ISO 14001 AS 9100 CERTIFIED • RoHS compliant  
P.O. Box 350166, Brooklyn, New York 11235-0003 (718) 934-4500 Fax (718) 332-4661

The Design Engineers Search Engine finds the model you need, instantly • For detailed performance specs & shopping online see [minicircuits.com](http://minicircuits.com)

## Typical Performance Curves

### VSWR

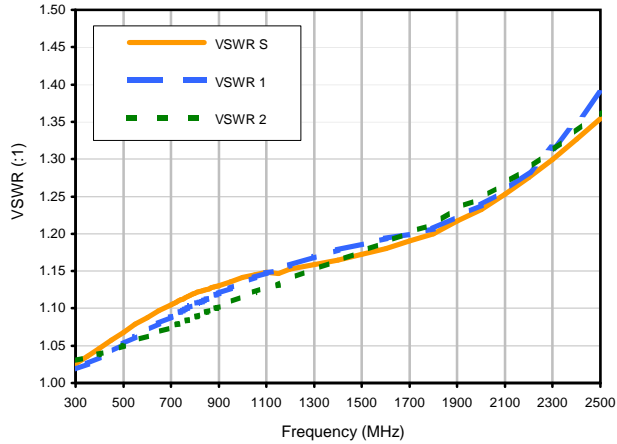

### VSWR SUM vs. TEMPERATURE

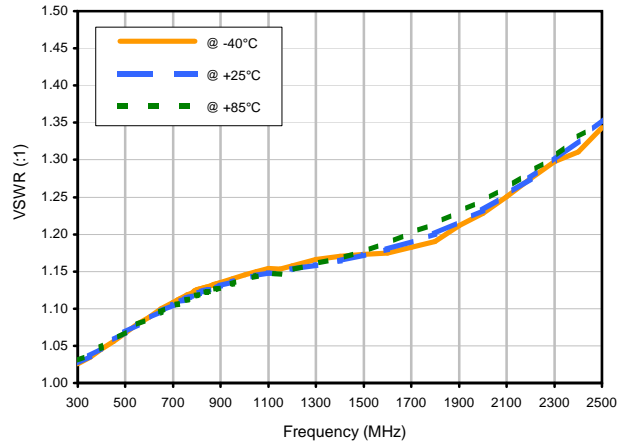

### VSWR OUT1 vs. TEMPERATURE

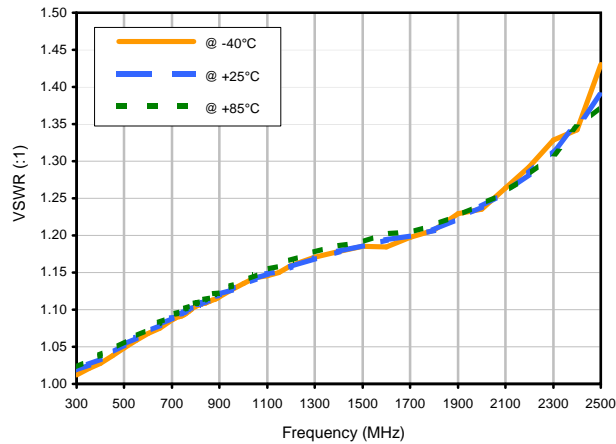

### Outline Dimensions

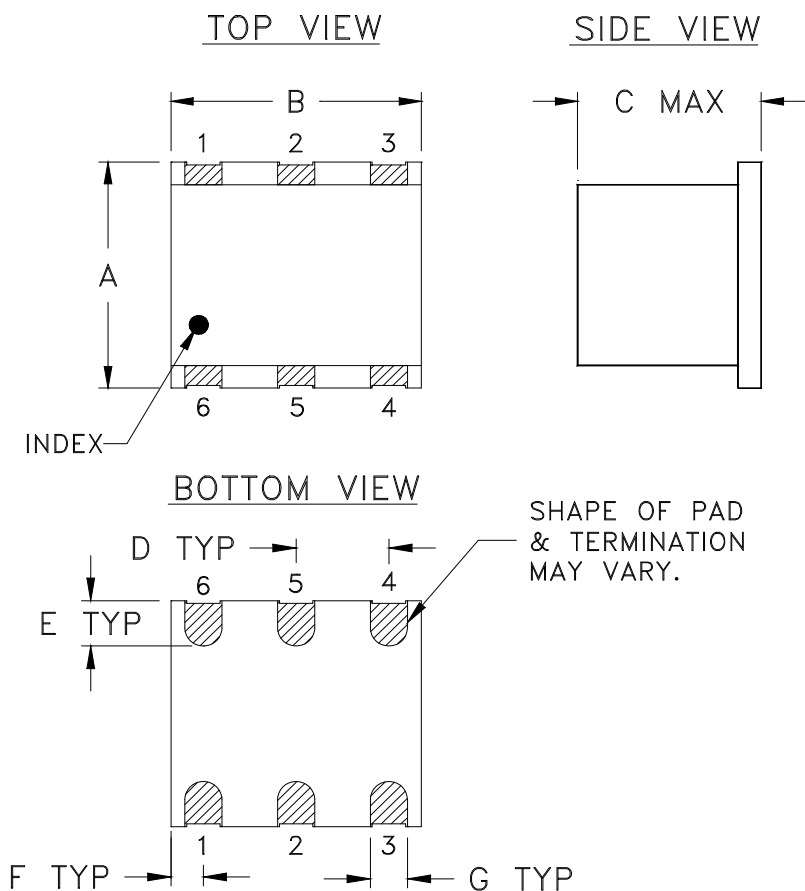

### PCB Land Pattern

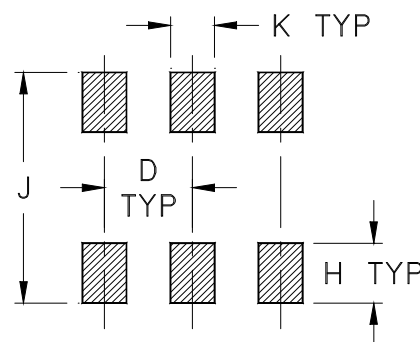

Suggested Layout,  
Tolerance to be within  $\pm .002$

CASE #	A	B	C	D	E	F	G	H	J	K	WT. GRAM
TT240	.250 (6.35)	.31 (7.87)	.20 (5.08)	.100 (2.54)	.050 (1.27)	.055 (1.40)	.040 (1.02)	.070 (1.78)	.270 (6.86)	.050 (1.27)	.50

Dimensions are in inches (mm). Tolerances: 2Pl.  $\pm .01$ ; 3 Pl.  $\pm .005$

#### Notes:

- Case material: Ceramic.
- Termination finish:
  - For RoHS Case Styles: 2-10 $\mu$  inch (.05-.25 microns) Gold plate over 100-300  $\mu$  inch (2.54-7.62 microns) Nickel plate. All models, (+) suffix.
  - For RoHS-5 Case Styles: Tin-Lead plate. All models, no (+) suffix.



P.O. Box 350166, Brooklyn, New York 11235-0003 (718) 934-4500 Fax (718) 332-4661 For detailed performance specs & shopping online see Mini-Circuits web site



The Design Engineers Search Engine Provides ACTUAL Data Instantly From MINI-CIRCUITS At: [www.minicircuits.com](http://www.minicircuits.com)

RF/IF MICROWAVE COMPONENTS

# Tape & Reel Packaging TR-F2

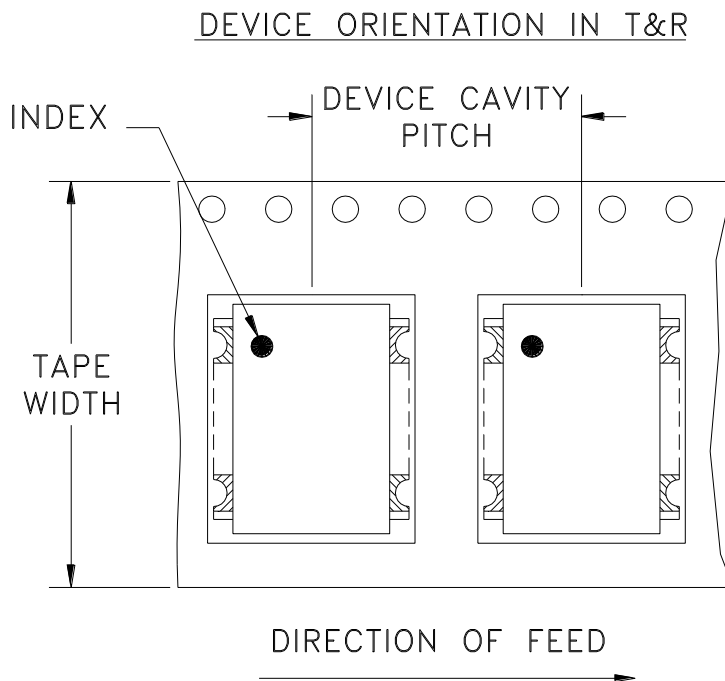

Tape Width, mm	Device Cavity Pitch, mm	Reel Size, inches	Devices per Reel See note
16	12	7	10
			20
			50
			100
			200
		13	500

Note: Please consult individual model data sheet to determine device per reel availability

Mini-Circuits carrier tape materials provide protection from ESD (Electro-Static Discharge) during handling and transportation. Tapes are static dissipative and comply with industry standards EIA-481/EIA-541.

Go to: [www.minicircuits.com/pages/pdfs/tape.pdf](http://www.minicircuits.com/pages/pdfs/tape.pdf)



INTERNET <http://www.minicircuits.com>

P.O. Box 350166, Brooklyn, New York 11235-0003 (718) 934-4500 Fax (718) 332-4661

Distribution Centers NORTH AMERICA 800-654-7949 • 417-335-5935 • Fax 417-335-5945 • EUROPE 44-1252-832600 • Fax 44-1252-837010

Mini-Circuits ISO 9001 & ISO 14001 Certified

THIRD ANGLE PROJECTION

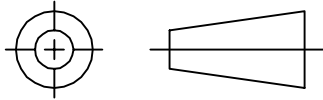

REVISIONS

REV	ECN No.	DESCRIPTION	DATE	DR	AUTH
OR	M82457	NEW RELEASE	12/02/02	MMG	HY
A	M102713	ADDED "...WITH SMOBC"	01/14/06	GF	IL

**SUGGESTED MOUNTING CONFIGURATION  
FOR TT240 CASE STYLE, "gp" PIN CONNECTION.**

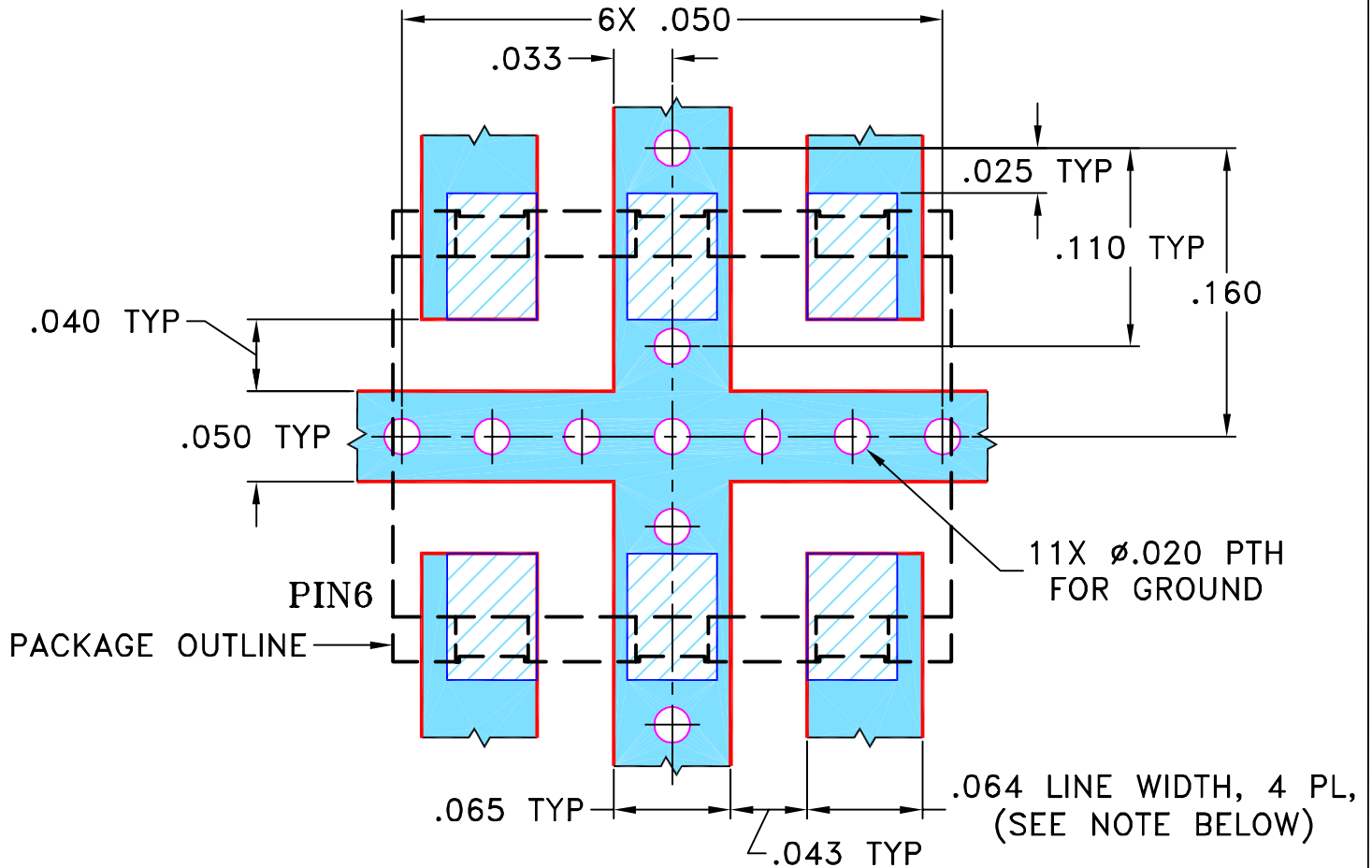

NOTES: 1. TRACE WIDTH IS SHOWN FOR ROGERS RO4350B WITH DIELECTRIC THICKNESS 0.030" ± 0.002"; COPPER: 1/2 OZ. EACH SIDE. FOR OTHER MATERIALS TRACE WIDTH MAY NEED TO BE MODIFIED.

2. BOTTOM SIDE OF THE PCB IS CONTINUOUS GROUND PLANE.



DENOTES PCB COPPER LAYOUT WITH SMOBC (SOLDER MASK OVER BARE COPPER)



DENOTES COPPER LAND PATTERN FREE OF SOLDER MASK

UNLESS OTHERWISE SPECIFIED	INITIALS	DATE
DIMENSIONS ARE IN INCHES	DRAWN MMG	09/09/02
TOLERANCES ON:	CHECKED AV	11/29/02
2 PL DECIMALS ±	APPROVED HY	12/02/02
3 PL DECIMALS ± .005		
ANGLES ±		
FRACTIONS ±		



**Mini-Circuits®**

13 Neptune Avenue  
Brooklyn NY 11235

**PL, gp, TT240, RPQ, TB-210**

Mini-Circuits®  
THIS DOCUMENT AND ITS CONTENTS ARE THE PROPERTY OF MINI-CIRCUITS. EXCEPT FOR USE EXPRESSLY GRANTED, IN WRITING, TO ITS VENDORS, VENDEE AND THE UNITED STATES GOVERNMENT, MINI-CIRCUITS RESERVES ALL PROPRIETARY DESIGN, USE, MANUFACTURING AND REPRODUCTION RIGHTS THERETO. THESE CONTENTS SHALL NOT BE USED, DUPLICATED OR DISCLOSED TO ANY OUTSIDE PARTY, IN WHOLE OR IN PART, WITHOUT WRITTEN PERMISSION OF MINI-CIRCUITS.

SIZE	CODE IDENT	DRAWING NO:	REV:
A	15542	98-PL-111	A
FILE:	98PL111	SCALE:	10:1
		SHEET:	1 OF 1

# Evaluation Board and Circuit

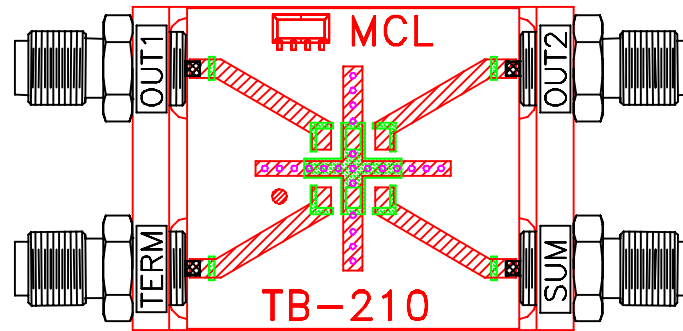

TB-210

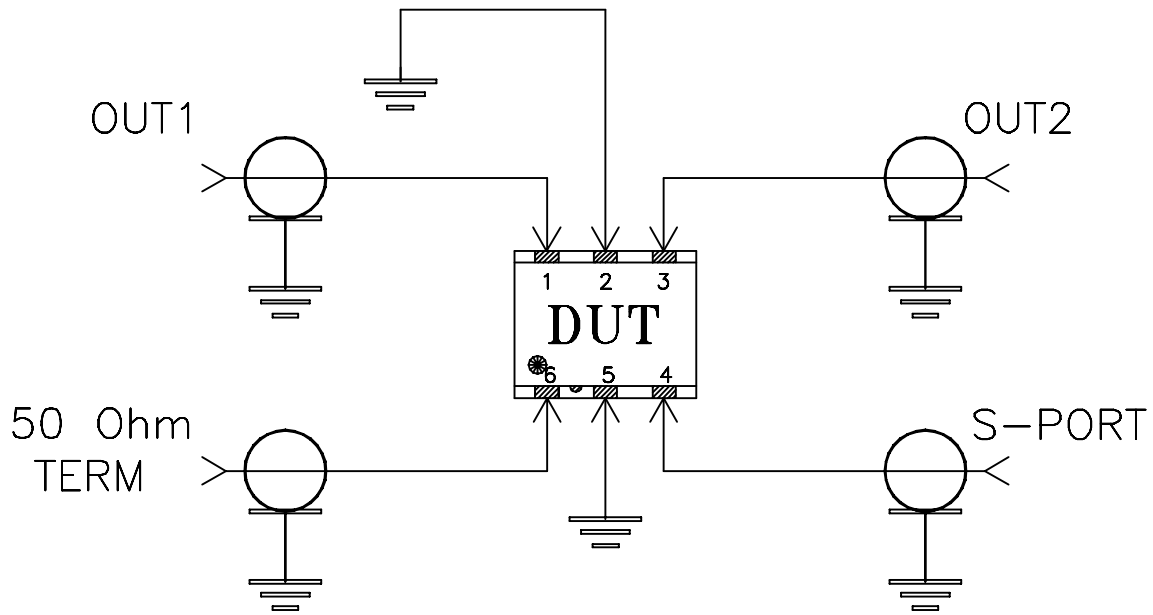

Schematic Diagram

## Notes:

1. SMA Female connectors.
2. PCB Material: Rogers R04350 or equivalent, Dielectric Constant=3.5, Thickness=.030 inch.

 Mini-Circuits®

All Mini-Circuits products are manufactured under exacting quality assurance and control standards, and are capable of meeting published specifications after being subjected to any or all of the following physical and environmental test.

Specification	Test/Inspection Condition	Reference/Spec
Operating Temperature	-40° to 85°C Ambient Environment	Individual Model Data Sheet
Storage Temperature	-55° to 100° C Ambient Environment	Individual Model Data Sheet
Humidity	90 to 95% RH, 240 hours, 50°C	MIL-STD-202, Method 103, Condition A, Except 50°C and end-point electrical test done within 12 hours
Thermal Shock	-55° to 100°C, 100 cycles	MIL-STD-202, Method 107, Condition A-3, except +100°C
Solder Reflow Heat	Sn-Pb Eutetic Process: 225°C peak Pb-Free Process 245° - 250°C peak	J-STD-020, Table 4-1, 4-2 and 5-2, Figure 5-1
Solderability	10X Magnification	J-STD-002, 95% Coverage
Vibration (High Frequency)	20g peak, 10-2000 Hz, 12 times in each of three perpendicular directions (total 36)	MIL-STD-202, Method 204, Condition D
Mechanical Shock	50g, 11 ms, 1/2-sine, 18 shocks: 3 each direction, each of 3 axes	MIL-STD-202, Method 213, Condition A
Marking Resistance to Solvents	Isopropyl alcohol + mineral spirits at 25°C; terpene defluxer at 25°C; distilled water + proylene glycol monomethyl ether + monoethanolamine at 63°C to 70°C	MIL-STD-202, Method 215