

Surface Mount Power Splitter/Combiner

2 Way-0° 50Ω 10 to 3000 MHz

RPS-2-30+



Generic photo used for illustration purposes only
CASE STYLE: TT1413

+RoHS Compliant
The +Suffix identifies RoHS Compliance. See our web site for RoHS Compliance methodologies and qualifications

Available Tape and Reel at no extra cost	
Reel Size	Devices/Reel
7"	10, 20, 50, 100, 200
13"	500

Maximum Ratings

Operating Temperature	-40°C to 85°C
Storage Temperature	-55°C to 100°C
Power Input (as a splitter)	0.5W max.
Internal Dissipation	0.125W max.

Permanent damage may occur if any of these limits are exceeded.

Pin Connections

SUM PORT	6
PORT 1	4
PORT 2	3
GROUND	1,2,5

Outline Drawing

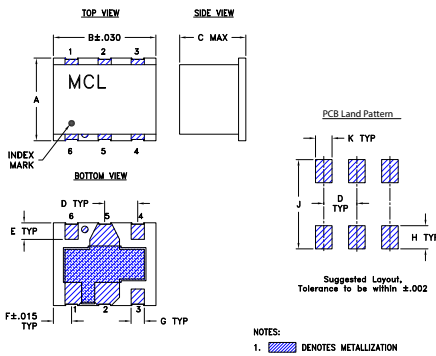

Outline Dimensions (inch/mm)

A	B	C	D	E	F	G	H	J	K	wt.
.250	.310	.20	.100	.050	.055	.040	.070	.270	.050	grams
6.35	7.87	5.08	2.54	1.27	1.40	1.02	1.78	6.86	1.27	0.5

Demo Board MCL P/N: TB-155
Suggested PCB Layout (PL-110)

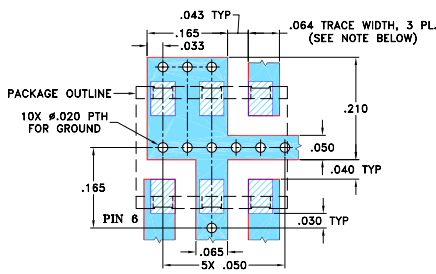

Notes

- Performance and quality attributes and conditions not expressly stated in this specification document are intended to be excluded and do not form a part of this specification document.
- Electrical specifications and performance data contained in this specification document are based on Mini-Circuit's applicable established test performance criteria and measurement instructions.
- The parts covered by this specification document are subject to Mini-Circuit's standard limited warranty and terms and conditions (collectively, "Standard Terms"); Purchasers of this part are entitled to the rights and benefits contained therein. For a full statement of the Standard Terms and the exclusive rights and remedies thereunder, please visit Mini-Circuit's website at www.minicircuits.com/MCLStore/terms.jsp

Features

- wideband, 10 to 3000 MHz
- good isolation, 22 dB typ.
- small size

Applications

- instrumentation
- catv
- cellular
- PCS
- GSM

Electrical Specifications

FREQ. RANGE (MHz)	ISOLATION (dB)			INSERTION LOSS (dB) ABOVE 3.0 dB			PHASE UNBALANCE (Degrees)			AMPLITUDE UNBALANCE (dB)								
	L	M	U	L	M	U	L	M	U	L	M	U						
f_L - f_U	Typ.	Min	Typ. Min	Typ. Min	Typ.	Min	Max.	Max.	Max.	Max.	Max.	Max.						
10-3000	19	12	22	15	15	9	0.6	1.0	0.9	1.5	1.2	2.5	2.0	4.0	8.0	0.3	0.6	1.2

L = low range [f_L to 10 f_L] M = mid range [10 f_L to $f_U/2$] U = upper range

Typical Performance Data

Frequency (MHz)	Total Loss ¹ (dB)		Amplitude Unbalance (dB)	Isolation (dB)	Phase Unbalance (deg.)	VSWR S	VSWR 1	VSWR 2
	S-1	S-2						
10.00	3.53	3.52	0.01	18.61	0.01	2.00	1.57	1.57
50.00	3.55	3.55	0.01	19.19	0.04	1.97	1.59	1.59
100.00	3.56	3.56	0.00	19.33	0.06	1.97	1.59	1.59
400.00	3.66	3.64	0.02	19.78	0.09	1.94	1.62	1.62
600.00	3.73	3.70	0.03	20.10	0.14	1.91	1.63	1.62
800.00	3.79	3.72	0.07	20.65	0.09	1.88	1.64	1.63
1000.00	3.85	3.74	0.11	21.64	0.02	1.87	1.66	1.63
1400.00	3.96	3.69	0.27	24.95	0.59	1.77	1.71	1.65
1600.00	4.00	3.66	0.34	26.31	0.88	1.74	1.72	1.64
1800.00	4.05	3.62	0.43	25.64	1.27	1.66	1.75	1.64
2000.00	4.18	3.65	0.52	23.38	1.59	1.61	1.74	1.63
2400.00	4.24	3.61	0.63	19.00	2.43	1.51	1.74	1.63
2600.00	4.32	3.65	0.67	17.42	2.83	1.54	1.75	1.64
2900.00	4.49	3.78	0.71	15.51	3.65	1.51	1.72	1.66
3000.00	4.68	3.93	0.75	15.02	4.13	1.52	1.72	1.68

1. Total Loss = Insertion Loss + 3dB splitter loss.

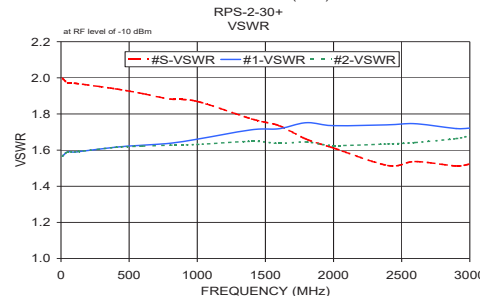
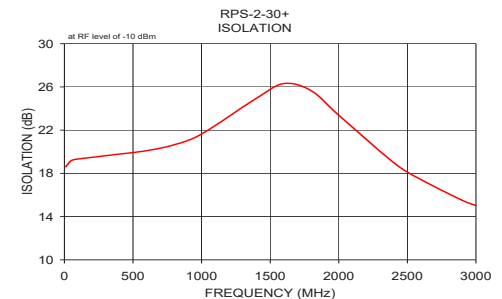
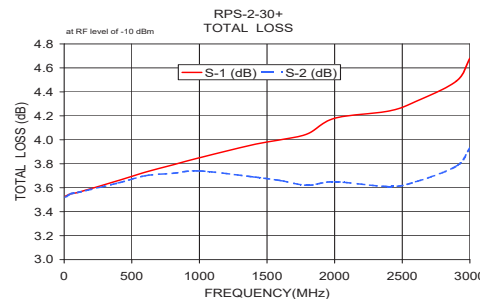

electrical schematic



2 Way-0° Power Splitter/Combiner

RPS-2-30+

Typical Performance Data

TEST CONDITIONS: INPUT POWER = 0dBm @Temperature = +25°C

FREQ. (MHz)	TOTAL LOSS ¹ (dB)		AMP. UNBAL. (dB)	PHASE UNBAL. (deg.)	ISOLATION (dB)	VSWR (:1)		
	S-1	S-2				S	1	2
10	3.55	3.54	0.01	0.03	18.84	1.99	1.57	1.57
25	3.56	3.56	0.00	0.01	18.99	1.98	1.57	1.58
50	3.57	3.57	0.00	0.05	19.01	1.97	1.58	1.58
75	3.59	3.58	0.01	0.11	19.07	1.97	1.58	1.58
100	3.59	3.59	0.00	0.11	19.13	1.96	1.59	1.59
150	3.60	3.61	0.01	0.14	19.22	1.95	1.59	1.59
200	3.62	3.62	0.00	0.18	19.33	1.94	1.60	1.60
250	3.63	3.63	0.00	0.23	19.44	1.94	1.60	1.60
300	3.64	3.64	0.00	0.24	19.56	1.93	1.60	1.61
400	3.66	3.65	0.01	0.31	19.82	1.92	1.61	1.61
500	3.68	3.67	0.01	0.43	20.09	1.91	1.61	1.61
600	3.70	3.68	0.02	0.45	20.38	1.90	1.61	1.62
700	3.71	3.69	0.02	0.52	20.72	1.88	1.62	1.62
800	3.73	3.70	0.03	0.58	21.15	1.87	1.62	1.63
900	3.75	3.71	0.04	0.61	21.67	1.86	1.63	1.63
1000	3.77	3.72	0.05	0.65	22.21	1.84	1.63	1.64
1100	3.79	3.73	0.06	0.65	22.82	1.82	1.64	1.65
1200	3.80	3.73	0.07	0.71	23.52	1.81	1.64	1.66
1300	3.83	3.74	0.09	0.69	24.15	1.79	1.65	1.66
1400	3.86	3.74	0.12	0.70	24.84	1.77	1.66	1.67
1450	3.86	3.74	0.12	0.68	25.15	1.75	1.66	1.67
1500	3.88	3.74	0.14	0.69	25.45	1.74	1.66	1.67
1550	3.90	3.75	0.15	0.68	25.66	1.73	1.66	1.67
1600	3.90	3.73	0.17	0.72	25.84	1.71	1.66	1.67
1650	3.91	3.74	0.17	0.68	25.99	1.70	1.66	1.67
1700	3.93	3.74	0.19	0.67	25.93	1.68	1.66	1.67
1800	3.96	3.74	0.22	0.70	25.77	1.65	1.67	1.67
1900	3.98	3.73	0.25	0.67	25.37	1.63	1.66	1.67
2000	4.01	3.73	0.28	0.63	24.76	1.60	1.66	1.66
2100	4.04	3.73	0.31	0.60	24.00	1.57	1.66	1.66
2200	4.07	3.74	0.33	0.52	23.15	1.53	1.65	1.65
2300	4.09	3.74	0.35	0.48	22.37	1.50	1.64	1.64
2400	4.13	3.74	0.39	0.41	21.41	1.47	1.63	1.62
2500	4.15	3.74	0.41	0.30	20.60	1.44	1.62	1.61
2600	4.20	3.75	0.45	0.22	19.73	1.41	1.60	1.60
2700	4.23	3.76	0.47	0.06	18.86	1.38	1.58	1.58
2800	4.27	3.78	0.49	0.09	18.06	1.35	1.57	1.56
2850	4.29	3.80	0.49	0.18	17.69	1.34	1.56	1.55
2900	4.30	3.82	0.48	0.36	17.31	1.32	1.55	1.53
2950	4.32	3.82	0.50	0.47	16.88	1.31	1.54	1.53
3000	4.35	3.82	0.53	0.56	16.50	1.29	1.53	1.52
3050	4.38	3.86	0.52	0.66	16.15	1.29	1.52	1.51
3100	4.40	3.87	0.53	0.88	15.75	1.28	1.51	1.50
3200	4.45	3.90	0.55	1.28	14.95	1.27	1.50	1.48
3400	4.60	4.05	0.55	2.23	13.39	1.31	1.47	1.44
3500	4.70	4.14	0.56	2.78	12.78	1.34	1.47	1.43
3600	4.78	4.23	0.55	3.47	12.05	1.41	1.46	1.42
3800	5.02	4.47	0.55	5.21	10.70	1.57	1.47	1.39
4000	5.32	4.73	0.58	7.59	9.45	1.79	1.46	1.36

¹ Total Loss = Insertion Loss+ 3dB Splitter Loss



2 Way-0° Power Splitter/Combiner

RPS-2-30+

Typical Performance Data

TEST CONDITIONS: INPUT POWER = 0dBm @Temperature = -40°C

FREQ. (MHz)	TOTAL LOSS ¹ (dB)		AMP. UNBAL. (dB)	PHASE UNBAL. (deg.)	ISOLATION (dB)	VSWR (:1)		
	S-1	S-2				S	1	2
10	3.54	3.54	0.00	0.01	17.64	1.99	1.61	1.62
25	3.56	3.55	0.01	0.00	20.48	1.99	1.66	1.66
50	3.57	3.57	0.00	0.02	21.30	1.99	1.68	1.68
75	3.58	3.57	0.01	0.04	21.57	1.98	1.69	1.69
100	3.58	3.58	0.00	0.05	21.67	1.96	1.69	1.69
150	3.58	3.58	0.00	0.05	21.74	1.95	1.68	1.69
200	3.60	3.59	0.01	0.07	21.74	1.95	1.69	1.70
250	3.60	3.59	0.01	0.09	21.71	1.94	1.69	1.69
300	3.61	3.60	0.01	0.09	21.75	1.94	1.69	1.70
400	3.62	3.60	0.02	0.15	21.94	1.93	1.69	1.70
500	3.63	3.61	0.02	0.19	22.14	1.92	1.70	1.70
600	3.64	3.61	0.03	0.18	22.41	1.91	1.70	1.70
700	3.65	3.62	0.03	0.27	22.75	1.90	1.71	1.71
800	3.66	3.61	0.05	0.26	23.20	1.89	1.71	1.71
900	3.67	3.61	0.06	0.26	23.74	1.87	1.71	1.72
1000	3.68	3.61	0.07	0.28	24.28	1.86	1.72	1.72
1100	3.70	3.61	0.09	0.26	24.87	1.84	1.72	1.73
1200	3.70	3.60	0.10	0.34	25.48	1.82	1.72	1.73
1300	3.73	3.61	0.12	0.26	25.91	1.80	1.73	1.74
1400	3.75	3.61	0.14	0.24	26.22	1.79	1.74	1.76
1450	3.75	3.60	0.15	0.23	26.23	1.78	1.74	1.74
1500	3.76	3.60	0.16	0.24	26.32	1.77	1.75	1.75
1550	3.77	3.60	0.17	0.18	26.32	1.76	1.75	1.76
1600	3.78	3.59	0.19	0.21	26.08	1.74	1.75	1.74
1650	3.78	3.58	0.20	0.17	25.79	1.72	1.75	1.74
1700	3.80	3.59	0.21	0.12	25.38	1.71	1.76	1.75
1800	3.83	3.58	0.25	0.14	24.61	1.69	1.76	1.74
1900	3.85	3.57	0.28	0.13	23.90	1.67	1.76	1.74
2000	3.86	3.57	0.29	0.11	23.01	1.64	1.76	1.76
2100	3.89	3.56	0.33	0.02	22.13	1.61	1.76	1.73
2200	3.91	3.56	0.35	0.03	21.43	1.57	1.75	1.72
2300	3.91	3.54	0.37	0.16	20.52	1.52	1.73	1.71
2400	3.95	3.53	0.42	0.18	19.51	1.49	1.73	1.68
2500	3.95	3.53	0.42	0.23	18.65	1.45	1.70	1.67
2600	3.98	3.54	0.44	0.40	17.79	1.43	1.69	1.68
2700	4.02	3.57	0.45	0.75	17.13	1.42	1.68	1.68
2800	4.04	3.55	0.49	0.80	16.42	1.37	1.66	1.63
2850	4.05	3.57	0.47	0.91	16.09	1.35	1.65	1.65
2900	4.06	3.58	0.48	1.21	15.74	1.34	1.65	1.64
2950	4.08	3.58	0.50	1.28	15.31	1.32	1.63	1.61
3000	4.09	3.59	0.50	1.43	14.92	1.31	1.62	1.61
3050	4.11	3.61	0.50	1.63	14.57	1.30	1.61	1.61
3100	4.13	3.64	0.49	1.93	14.19	1.30	1.60	1.61
3200	4.21	3.66	0.55	2.54	13.49	1.31	1.59	1.56
3400	4.33	3.80	0.53	3.50	12.02	1.34	1.56	1.52
3500	4.40	3.86	0.54	4.44	11.47	1.36	1.58	1.55
3600	4.49	3.92	0.57	5.18	10.84	1.41	1.57	1.51
3800	4.78	4.14	0.64	7.24	9.52	1.60	1.57	1.44
4000	5.07	4.38	0.70	9.35	8.47	1.79	1.55	1.39

¹ Total Loss = Insertion Loss+ 3dB Splitter Loss



2 Way-0° Power Splitter/Combiner

RPS-2-30+

Typical Performance Data

TEST CONDITIONS: INPUT POWER = 0dBm @Temperature = +85°C

FREQ. (MHz)	TOTAL LOSS ¹ (dB)		AMP. UNBAL. (dB)	PHASE UNBAL. (deg.)	ISOLATION (dB)	VSWR (:1)		
	S-1	S-2				S	1	2
10	3.55	3.55	0.00	0.03	16.41	1.99	1.45	1.45
25	3.57	3.56	0.01	0.03	16.49	1.98	1.46	1.46
50	3.58	3.58	0.00	0.09	16.50	1.96	1.46	1.46
75	3.59	3.59	0.00	0.14	16.56	1.96	1.46	1.46
100	3.61	3.61	0.00	0.17	16.63	1.96	1.47	1.47
150	3.63	3.63	0.00	0.23	16.77	1.95	1.48	1.48
200	3.64	3.64	0.00	0.32	16.92	1.94	1.48	1.49
250	3.65	3.65	0.00	0.37	17.07	1.93	1.49	1.49
300	3.67	3.67	0.00	0.43	17.20	1.93	1.49	1.50
400	3.69	3.69	0.00	0.58	17.44	1.91	1.50	1.50
500	3.71	3.71	0.00	0.72	17.70	1.90	1.50	1.51
600	3.73	3.73	0.00	0.79	18.00	1.89	1.51	1.52
700	3.75	3.74	0.01	0.91	18.37	1.88	1.51	1.52
800	3.77	3.76	0.01	0.98	18.82	1.86	1.52	1.53
900	3.80	3.77	0.03	1.05	19.31	1.85	1.53	1.54
1000	3.82	3.79	0.03	1.13	19.86	1.83	1.54	1.55
1100	3.85	3.80	0.05	1.16	20.42	1.81	1.54	1.56
1200	3.87	3.81	0.06	1.24	21.07	1.79	1.55	1.56
1300	3.91	3.83	0.08	1.28	21.72	1.77	1.55	1.57
1400	3.94	3.83	0.11	1.37	22.44	1.75	1.56	1.57
1450	3.95	3.83	0.12	1.37	22.81	1.73	1.56	1.57
1500	3.96	3.83	0.13	1.40	23.23	1.72	1.56	1.57
1550	3.98	3.83	0.15	1.41	23.59	1.71	1.56	1.57
1600	3.99	3.84	0.15	1.49	23.96	1.69	1.56	1.57
1650	4.01	3.84	0.17	1.47	24.40	1.68	1.56	1.57
1700	4.02	3.85	0.17	1.49	24.73	1.66	1.56	1.58
1800	4.06	3.85	0.21	1.56	25.46	1.63	1.56	1.58
1900	4.09	3.86	0.23	1.60	26.05	1.60	1.56	1.58
2000	4.12	3.86	0.26	1.60	26.53	1.57	1.56	1.57
2100	4.15	3.87	0.28	1.67	26.86	1.53	1.55	1.56
2200	4.18	3.88	0.30	1.63	26.76	1.50	1.54	1.56
2300	4.21	3.88	0.33	1.64	26.48	1.47	1.53	1.55
2400	4.25	3.89	0.36	1.61	25.84	1.44	1.52	1.54
2500	4.28	3.91	0.38	1.57	25.06	1.41	1.51	1.53
2600	4.32	3.91	0.41	1.54	24.21	1.38	1.50	1.51
2700	4.35	3.92	0.43	1.47	22.99	1.34	1.48	1.49
2800	4.39	3.95	0.44	1.39	21.83	1.31	1.47	1.48
2850	4.41	3.96	0.45	1.34	21.34	1.30	1.46	1.48
2900	4.43	3.98	0.45	1.24	20.79	1.28	1.45	1.47
2950	4.45	3.99	0.46	1.13	20.17	1.27	1.45	1.46
3000	4.47	4.00	0.48	1.08	19.69	1.26	1.44	1.45
3050	4.51	4.04	0.47	1.05	19.25	1.24	1.44	1.45
3100	4.52	4.04	0.48	0.89	18.61	1.23	1.43	1.43
3200	4.58	4.10	0.48	0.61	17.59	1.22	1.42	1.43
3400	4.69	4.21	0.48	0.11	15.52	1.24	1.39	1.40
3500	4.76	4.32	0.44	0.31	14.58	1.29	1.38	1.39
3600	4.85	4.40	0.44	1.14	13.70	1.35	1.38	1.39
3800	5.01	4.62	0.39	2.70	11.99	1.50	1.39	1.38
4000	5.29	4.94	0.35	4.85	10.45	1.74	1.40	1.39

¹ Total Loss = Insertion Loss+ 3dB Splitter Loss



2 Way-0° Power Splitter/Combiner

RPS-2-30+

Typical Performance Curves

Total Loss

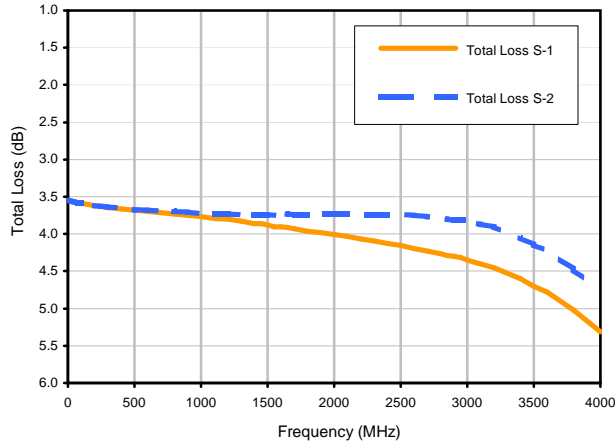

Total Loss S-1 vs. TEMPERATURE

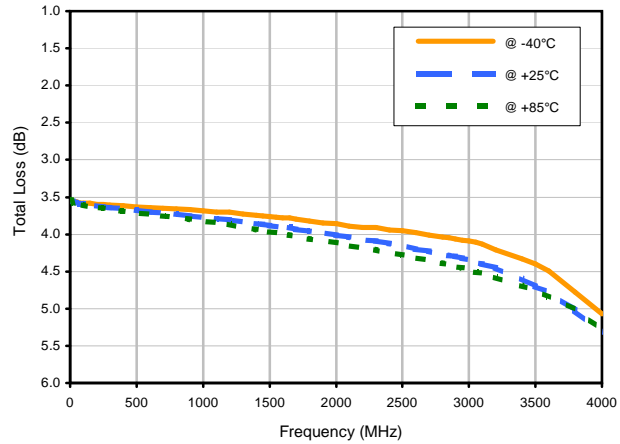

Amplitude Unbalance vs. TEMPERATURE

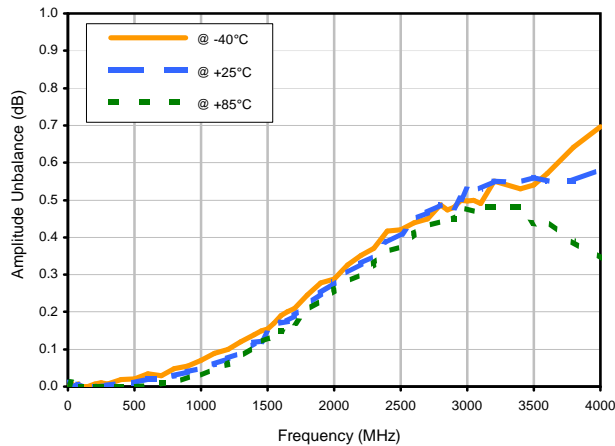

Phase Unbalance vs. TEMPERATURE

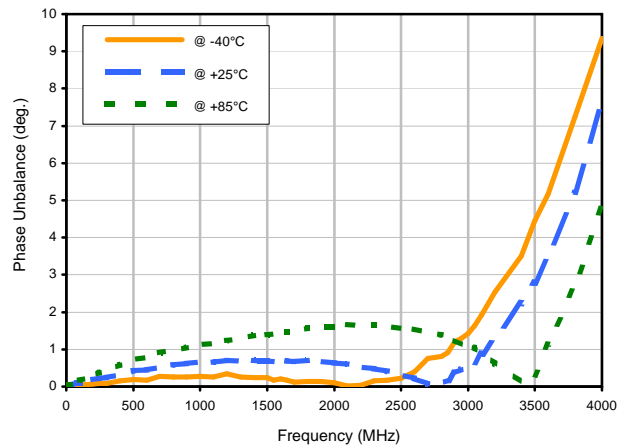

Isolation 1-2 vs. TEMPERATURE

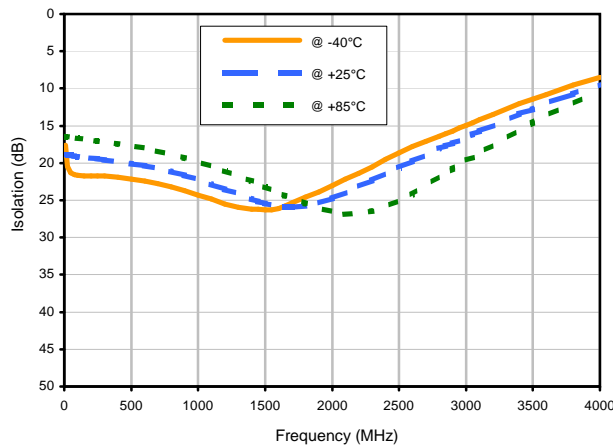

REV. X2
RPS-2-30+
100627
Page 1 of 2



IF/RF MICROWAVE COMPONENTS • ISO 9001 ISO 14001 AS 9100 CERTIFIED • RoHS compliant
P.O. Box 350166, Brooklyn, New York 11235-0006 (718) 934-4500 Fax (718) 332-4661



The Design Engineers Search Engine finds the model you need, Instantly • For detailed performance specs & shopping online see



Typical Performance Curves

VSWR

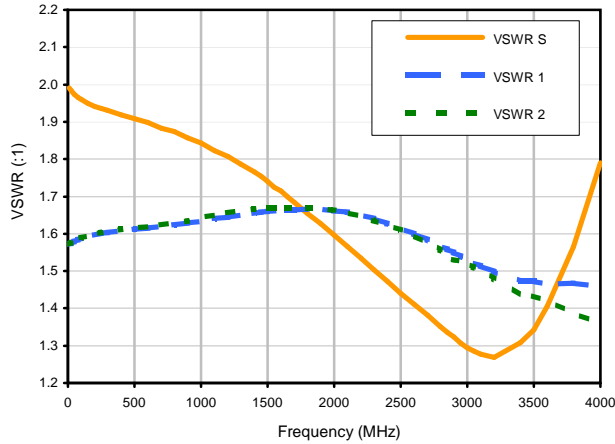

VSWR SUM vs. TEMPERATURE

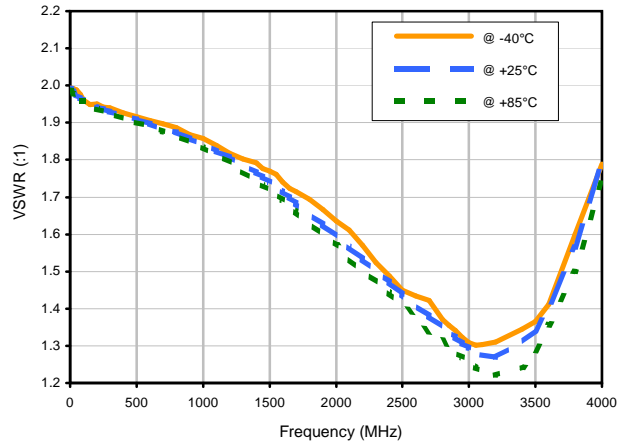

VSWR OUT1 vs. TEMPERATURE

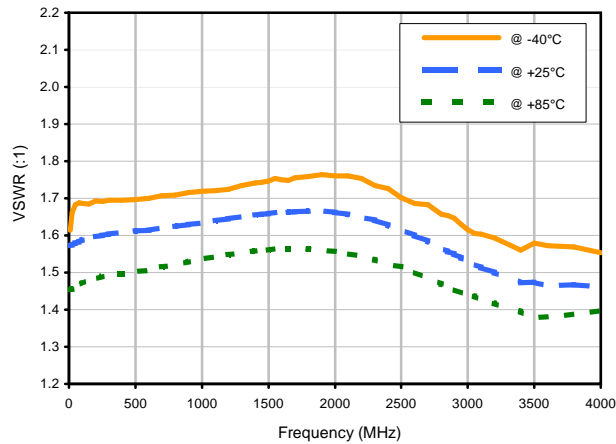

TOP VIEW

SIDE VIEW

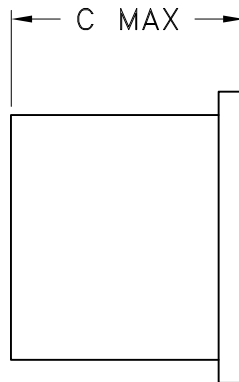
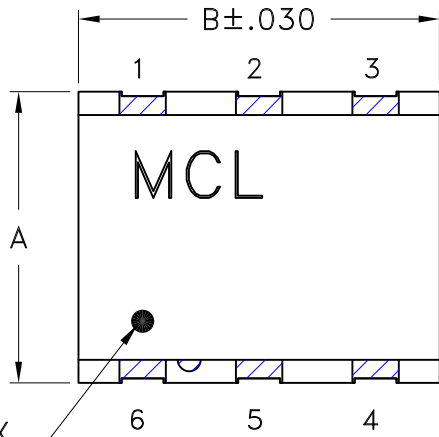

PCB Land Pattern

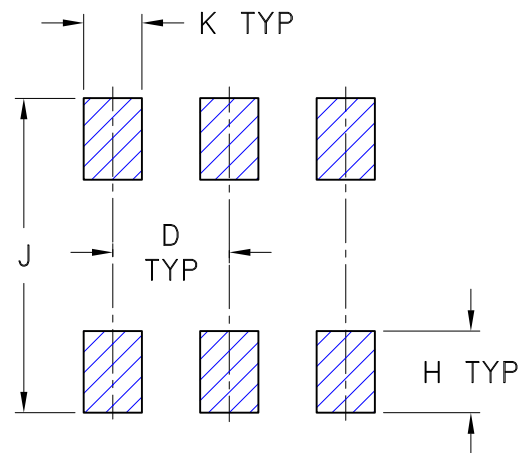

BOTTOM VIEW

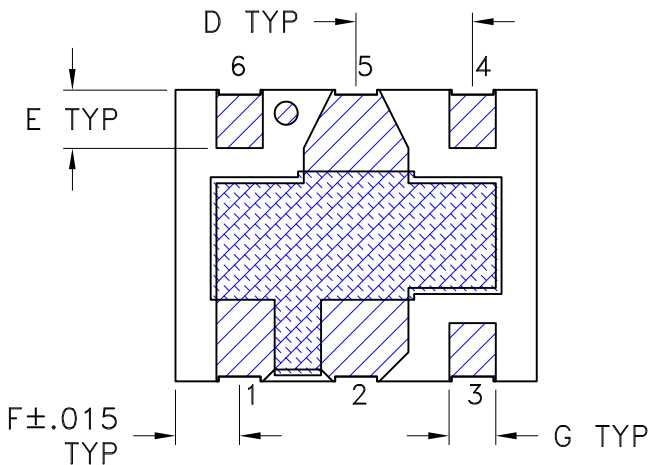

Suggested Layout,
Tolerance to be within $\pm.002$

NOTES:

1.  DENOTES METALLIZATION

CASE#	A	B	C	D	E	F	G	H	J	K	WT, GRAM
TT1413	.250 (6.35)	.310 (7.87)	.20 (5.08)	.100 (2.54)	.050 (1.27)	.055 (1.40)	.040 (1.02)	.070 (1.78)	.270 (6.86)	.050 (1.27)	.50

Dimensions are in inches (mm). Tolerances: 2 Pl. $\pm.01$; 3 Pl. $\pm.005$

Notes:

1. Case material: Ceramic.
2. Termination finish: Gold Plating.



P.O. Box 350166, Brooklyn, New York 11235-0003 (718) 934-4500 Fax (718) 332-4661 For detailed performance specs & shopping online see Mini-Circuits web site



The Design Engineers Search Engine Provides ACTUAL Data Instantly From MINI-CIRCUITS At: www.minicircuits.com

RF/IF MICROWAVE COMPONENTS

Tape & Reel Packaging TR-F2

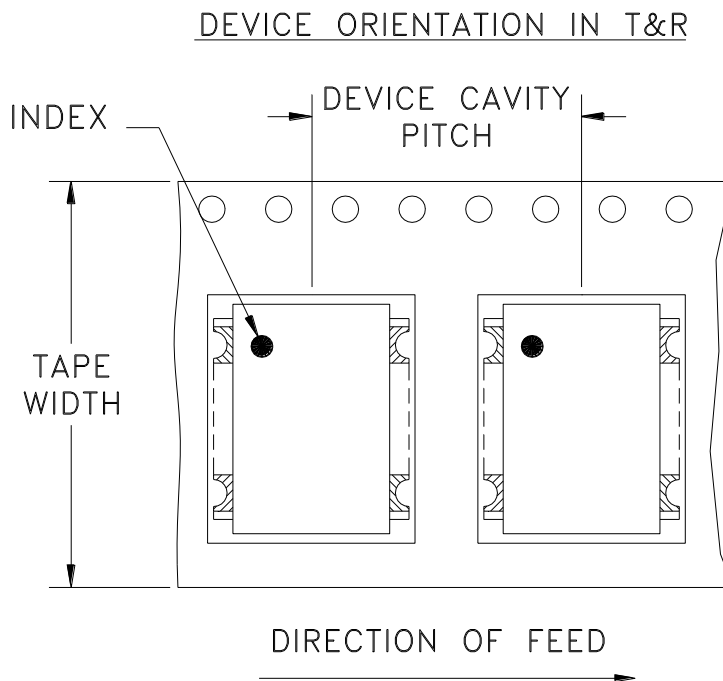

Tape Width, mm	Device Cavity Pitch, mm	Reel Size, inches	Devices per Reel See note
16	12	7	10
			20
			50
			100
			200
		13	500

Note: Please consult individual model data sheet to determine device per reel availability

Mini-Circuits carrier tape materials provide protection from ESD (Electro-Static Discharge) during handling and transportation. Tapes are static dissipative and comply with industry standards EIA-481/EIA-541.

Go to: www.minicircuits.com/pages/pdfs/tape.pdf



INTERNET <http://www.minicircuits.com>

P.O. Box 350166, Brooklyn, New York 11235-0003 (718) 934-4500 Fax (718) 332-4661

Distribution Centers NORTH AMERICA 800-654-7949 • 417-335-5935 • Fax 417-335-5945 • EUROPE 44-1252-832600 • Fax 44-1252-837010

Mini-Circuits ISO 9001 & ISO 14001 Certified

THIRD ANGLE PROJECTION

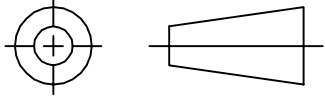

REVISIONS

REV	ECN No.	DESCRIPTION	DATE	DR	AUTH
OR	M82456	NEW RELEASE	12/02/02	MMG	HY
A	M102713	ADDED "...WITH SMOBC"	01/14/06	GF	IL
B	M121379	TT1413 WAS TT240, "06SP05" WAS "gn"	02/17/09	MMG	IL

SUGGESTED MOUNTING CONFIGURATION FOR
TT1413 CASE STYLE, "06SP05" PIN CODE

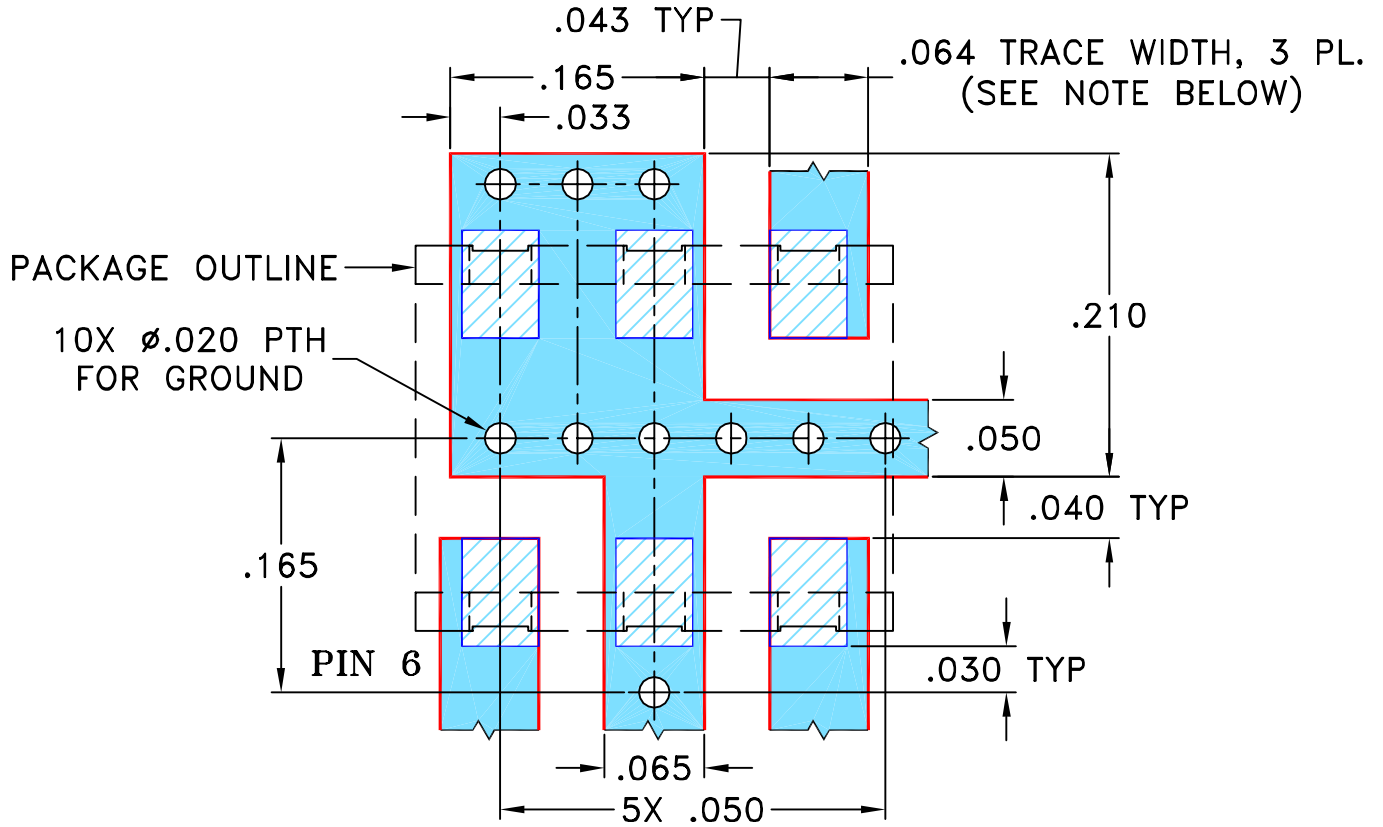

NOTES: 1. TRACE WIDTH IS SHOWN FOR ROGERS RO4350B WITH DIELECTRIC THICKNESS 0.030" ± 0.002"; COPPER: 1/2 OZ. EACH SIDE. FOR OTHER MATERIALS TRACE WIDTH MAY NEED TO BE MODIFIED.
2. BOTTOM SIDE OF THE PCB IS CONTINUOUS GROUND PLANE.



DENOTES PCB COPPER LAYOUT WITH SMOBC (SOLDER MASK OVER BARE COPPER)



DENOTES COPPER LAND PATTERN FREE OF SOLDER MASK

UNLESS OTHERWISE SPECIFIED

INITIALS

DATE

DIMENSIONS ARE IN INCHES

DRAWN

MMG

11/15/02

TOLERANCES ON:

CHECKED

AV

11/29/02

2 PL DECIMALS ±

APPROVED

HY

12/02/02

3 PL DECIMALS ± .005

ANGLES ±

FRACTIONS ±

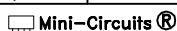

THIS DOCUMENT AND ITS CONTENTS ARE THE PROPERTY OF MINI-CIRCUITS. EXCEPT FOR USE EXPRESSLY GRANTED, IN WRITING, TO ITS VENDORS, VENDEE AND THE UNITED STATES GOVERNMENT, MINI-CIRCUITS RESERVES ALL PROPRIETARY DESIGN, USE, MANUFACTURING AND REPRODUCTION RIGHTS THERETO. THESE CONTENTS SHALL NOT BE USED, DUPLICATED OR DISCLOSED TO ANY OUTSIDE PARTY, IN WHOLE OR IN PART, WITHOUT WRITTEN PERMISSION OF MINI-CIRCUITS.

Mini-Circuits® 13 Neptune Avenue
Brooklyn NY 11235

PL, 06SP05, TT1413, RPS, TB-155

SIZE

CODE IDENT

DRAWING NO:

REV:

A

15542

98-PL-110

B

FILE:

98PL110

SCALE:

8:1

SHEET:

1 OF 1

ASHEETA1.DWG REV:A DATE:01/12/95

Evaluation Board and Circuit

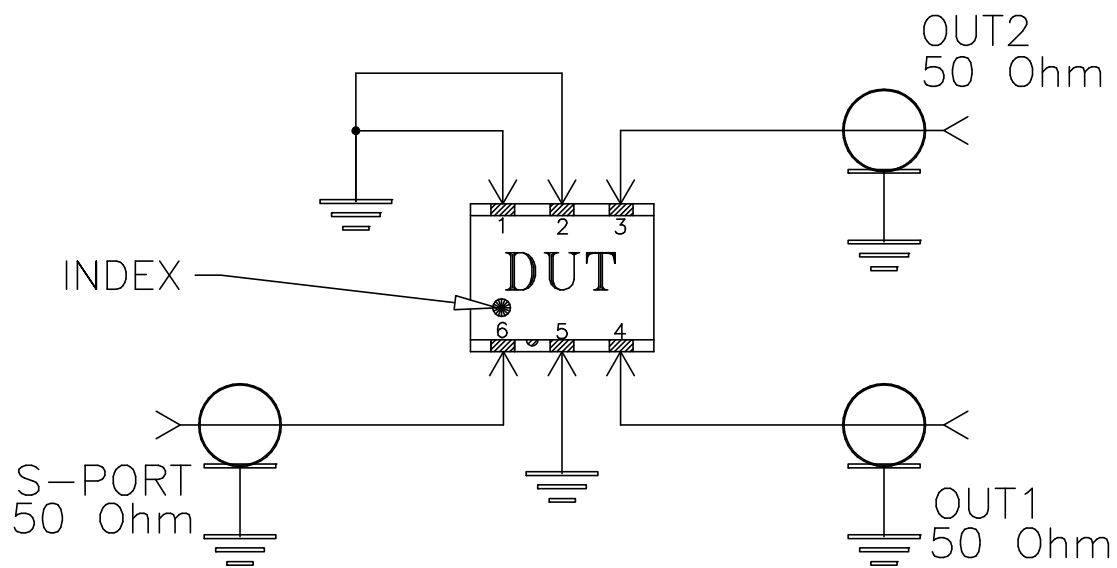
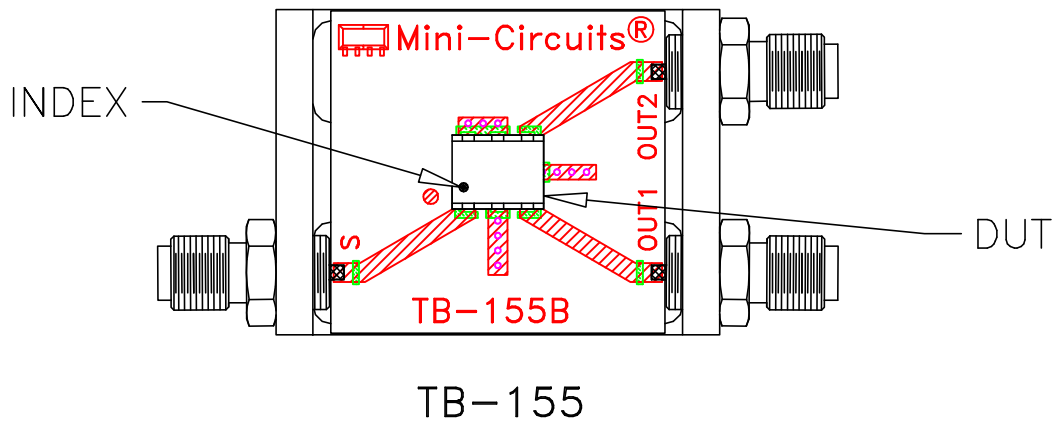

Schematic Diagram

Notes:

1. SMA Female connectors.
2. PCB Material: Rogers R04350 or equivalent,
Dielectric Constant=3.5, Thickness=.030 inch.

 **Mini-Circuits®**

All Mini-Circuits products are manufactured under exacting quality assurance and control standards, and are capable of meeting published specifications after being subjected to any or all of the following physical and environmental test.

Specification	Test/Inspection Condition	Reference/Spec
Operating Temperature	-40° to 85°C Ambient Environment	Individual Model Data Sheet
Storage Temperature	-55° to 100° C Ambient Environment	Individual Model Data Sheet
Humidity	90 to 95% RH, 240 hours, 50°C	MIL-STD-202, Method 103, Condition A, Except 50°C and end-point electrical test done within 12 hours
Thermal Shock	-55° to 100°C, 100 cycles	MIL-STD-202, Method 107, Condition A-3, except +100°C
Solder Reflow Heat	Sn-Pb Eutetic Process: 225°C peak Pb-Free Process 245° - 250°C peak	J-STD-020, Table 4-1, 4-2 and 5-2, Figure 5-1
Solderability	10X Magnification	J-STD-002, 95% Coverage
Vibration (High Frequency)	20g peak, 10-2000 Hz, 12 times in each of three perpendicular directions (total 36)	MIL-STD-202, Method 204, Condition D
Mechanical Shock	50g, 11 ms, 1/2-sine, 18 shocks: 3 each direction, each of 3 axes	MIL-STD-202, Method 213, Condition A
Marking Resistance to Solvents	Isopropyl alcohol + mineral spirits at 25°C; terpene defluxer at 25°C; distilled water + proylene glycol monomethyl ether + monoethanolamine at 63°C to 70°C	MIL-STD-202, Method 215