



SURFACE MOUNT

Power Splitter/Combiner

SCA-3-11+



3 Way-0° 50Ω 100 to 940 MHz

FEATURES

- Wideband, 100 to 940 MHz
- Good input port matching VSWR, 1.10 typ.
- Small surface mount package
- Protected by U.S. Patent 6,965,280



Generic photo used for illustration purposes only

CASE STYLE: DZ943

+RoHS Compliant

The +Suffix identifies RoHS Compliance. See our website for methodologies and qualifications

APPLICATIONS

- Cellular
- ISM
- Land mobile

ELECTRICAL SPECIFICATIONS AT 25°C¹

Parameter	Frequency (MHz)	Min.	Typ.	Max.	Unit
Frequency Range		100		940	MHz
Insertion Loss, above 4.8 dB	100-940		0.7	1.5	dB
Isolation	100-940	14	20		dB
Phase Unbalance	100-940			7.0	Degree
Amplitude Unbalance	100-940			0.7	dB

1. Tested on Evaluation Board TB-SCA-3-11+

MAXIMUM RATINGS

Parameter	Ratings
Operating Temperature	-45°C to 85°C
Storage Temperature	-55°C to 100°C
Power Input (as a splitter)	0.5W max.
Internal Dissipation	0.25W max.

Permanent damage may occur if any of these limits are exceeded.

ELECTRICAL SCHEMATIC





SURFACE MOUNT

Power Splitter/Combiner

SCA-3-11+

Mini-Circuits

3 Way-0° 50Ω 100 to 940 MHz

PIN CONNECTIONS

SUM PORT (PORT S)	3
PORT 1	6
PORT 2	8
PORT 3	10
GROUND	1,2,4,5,7,9

***PRODUCT MARKING:** SCA-3-11

*Marking may contain other features or characters for internal lot control

**EVALUATION BOARD MCL P/N: TB-SCA-3-11+
SUGGESTED PCB LAYOUT (PL-144)**

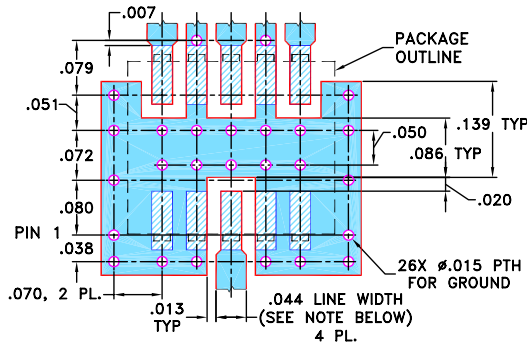

NOTE: 1. TRACE WIDTH IS SHOWN FOR ROGERS RO4350B WITH DIELECTRIC THICKNESS 0.020" ± 0.0015"; COPPER: 1/2 OZ. EACH SIDE. FOR OTHER MATERIALS TRACE WIDTH MAY NEED TO BE MODIFIED.
2. BOTTOM SIDE OF THE PCB IS CONTINUOUS GROUND PLANE.

- DENOTES PCB COPPER LAYOUT WITH SMOBC (SOLDER MASK OVER BARE COPPER)
- DENOTES COPPER LAND PATTERN FREE OF SOLDER MASK

OUTLINE DRAWING

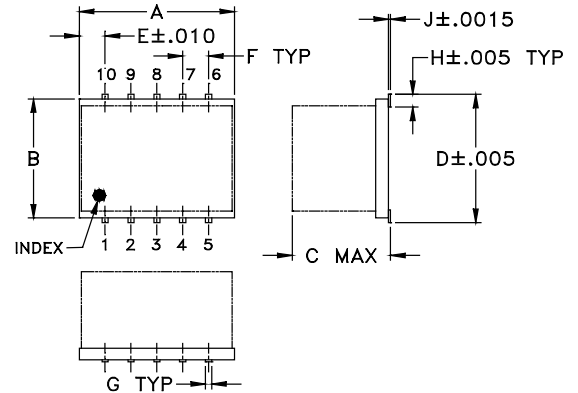

PCB Land Pattern

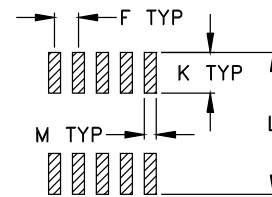

OUTLINE DIMENSIONS (Inches/mm)

A	B	C	D	E	F	G
.30	.250	.190	.266	.050	.050	.012
7.62	6.35	4.83	6.76	1.27	1.27	0.30
H	J	K	L	M		wt
.029	.004	.085	.296	.030		grams
0.74	0.10	2.16	7.52	0.76		0.5

TAPE & REEL INFORMATION: F34





SURFACE MOUNT

Power Splitter/Combiner

SCA-3-11+

Mini-Circuits

3 Way-0° 50Ω 100 to 940 MHz

TYPICAL PERFORMANCE DATA

Frequency (MHz)	Total Loss ¹ (dB)			Amplitude Unbalance (dB)	Isolation (dB)			Phase Unbalance (deg.)	VSWR (:1)		
	S-1	S-2	S-3		1-2	1-3	2-3		S	1	2
100.00	5.21	5.25	5.20	0.05	16.94	16.71	16.84	0.44	1.31	1.85	1.88
132.00	5.20	5.23	5.19	0.04	17.02	16.75	16.91	0.50	1.23	1.83	1.86
164.00	5.19	5.22	5.17	0.05	17.08	16.77	16.91	0.62	1.18	1.79	1.83
196.00	5.18	5.22	5.18	0.04	17.16	16.76	16.92	0.71	1.13	1.78	1.81
244.00	5.19	5.23	5.19	0.04	17.40	16.93	17.09	0.92	1.09	1.76	1.80
292.00	5.18	5.22	5.19	0.04	17.62	16.98	17.19	1.04	1.07	1.72	1.77
340.00	5.20	5.24	5.21	0.04	17.93	17.16	17.42	1.38	1.03	1.70	1.76
388.00	5.22	5.26	5.24	0.04	18.27	17.34	17.65	1.45	1.02	1.68	1.73
446.00	5.24	5.28	5.29	0.05	18.77	17.65	18.04	1.70	1.01	1.64	1.72
524.00	5.27	5.30	5.33	0.06	19.46	17.98	18.54	1.89	1.04	1.61	1.70
602.00	5.33	5.33	5.42	0.09	20.29	18.44	19.13	2.07	1.08	1.58	1.66
706.00	5.42	5.42	5.51	0.09	21.20	18.84	19.69	2.46	1.12	1.52	1.61
810.00	5.55	5.49	5.63	0.14	21.81	18.97	20.04	3.09	1.17	1.44	1.54
914.00	5.66	5.59	5.81	0.22	21.95	18.97	20.14	3.32	1.24	1.37	1.47
1100.00	5.98	5.83	6.17	0.33	21.67	18.66	20.02	3.83	1.36	1.25	1.32

1. Total Loss = Insertion Loss + 4.8 dB splitter loss.

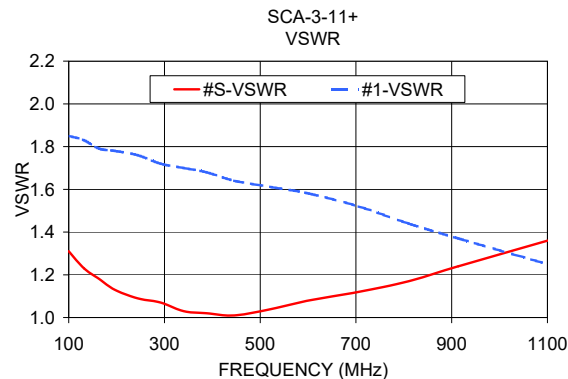
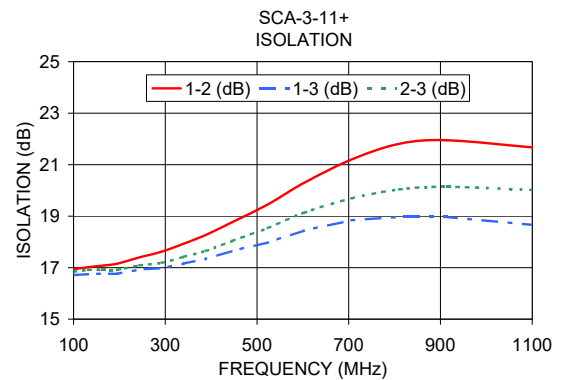
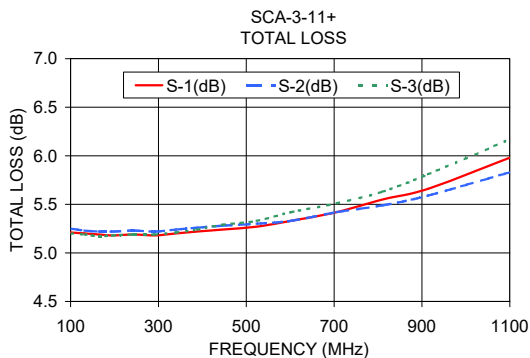

- NOTES**
- A. Performance and quality attributes and conditions not expressly stated in this specification document are intended to be excluded and do not form a part of this specification document.
 - B. Electrical specifications and performance data contained in this specification document are based on Mini-Circuit's applicable established test performance criteria and measurement instructions.
 - C. The parts covered by this specification document are subject to Mini-Circuits standard limited warranty and terms and conditions (collectively, "Standard Terms"); Purchasers of this part are entitled to the rights and benefits contained therein. For a full statement of the standard. Terms and the exclusive rights and remedies thereunder, please visit Mini-Circuits' website at www.minicircuits.com/terms/viewterm.html



3 Way-0° Power Splitter/Combiner

SCA-3-11+

Typical Performance Data

TEST CONDITIONS: INPUT POWER = 0dBm @Temperature = +25°C

FREQ. (MHz)	TOTAL LOSS ¹ (dB)			AMP. UNBAL. (dB)	PHASE UNBAL. (deg.)	ISOLATION (dB)			VSWR (:1)			
	S-1	S-2	S-3			1-2	1-3	2-3	S	1	2	3
20	6.93	6.98	6.96	0.05	0.22	16.28	16.33	16.42	3.70	2.71	2.71	2.69
50	5.50	5.52	5.51	0.02	0.12	16.16	16.04	16.27	1.79	2.11	2.11	2.09
60	5.41	5.43	5.42	0.03	0.13	16.17	16.03	16.28	1.63	2.06	2.06	2.04
70	5.34	5.37	5.36	0.03	0.16	16.18	16.03	16.28	1.53	2.02	2.03	2.01
80	5.30	5.34	5.32	0.03	0.18	16.19	16.03	16.29	1.46	2.00	2.00	1.98
90	5.28	5.31	5.29	0.03	0.19	16.20	16.03	16.29	1.41	1.98	1.99	1.97
100	5.26	5.29	5.27	0.03	0.20	16.22	16.03	16.31	1.36	1.96	1.97	1.95
110	5.24	5.27	5.26	0.03	0.25	16.24	16.04	16.33	1.33	1.95	1.96	1.94
120	5.23	5.26	5.24	0.04	0.23	16.25	16.04	16.35	1.30	1.94	1.95	1.93
130	5.21	5.25	5.24	0.04	0.25	16.28	16.04	16.36	1.28	1.93	1.94	1.92
140	5.21	5.24	5.23	0.03	0.30	16.30	16.05	16.38	1.26	1.92	1.93	1.91
150	5.20	5.24	5.22	0.04	0.34	16.32	16.06	16.40	1.24	1.92	1.92	1.91
200	5.18	5.23	5.21	0.04	0.49	16.46	16.11	16.52	1.17	1.88	1.88	1.87
225	5.18	5.23	5.21	0.04	0.59	16.54	16.16	16.61	1.15	1.87	1.86	1.85
250	5.18	5.22	5.21	0.04	0.62	16.65	16.22	16.71	1.14	1.86	1.84	1.84
275	5.18	5.22	5.21	0.04	0.72	16.74	16.27	16.79	1.12	1.84	1.83	1.82
300	5.18	5.22	5.22	0.04	0.81	16.83	16.30	16.87	1.11	1.83	1.81	1.80
325	5.19	5.22	5.22	0.03	0.87	16.94	16.36	16.97	1.10	1.82	1.79	1.79
350	5.19	5.22	5.23	0.04	0.98	17.07	16.43	17.08	1.10	1.81	1.77	1.77
375	5.20	5.22	5.25	0.05	1.02	17.17	16.48	17.18	1.10	1.80	1.75	1.76
400	5.21	5.23	5.26	0.05	1.10	17.29	16.54	17.30	1.10	1.78	1.73	1.74
425	5.22	5.23	5.27	0.05	1.19	17.41	16.60	17.41	1.10	1.77	1.71	1.73
450	5.23	5.24	5.28	0.05	1.26	17.53	16.67	17.52	1.10	1.76	1.69	1.71
475	5.25	5.24	5.30	0.06	1.34	17.65	16.72	17.63	1.11	1.75	1.67	1.69
500	5.26	5.25	5.32	0.08	1.38	17.75	16.77	17.73	1.12	1.74	1.65	1.68
525	5.28	5.26	5.34	0.08	1.44	17.86	16.81	17.83	1.13	1.72	1.64	1.66
550	5.30	5.27	5.37	0.10	1.48	17.95	16.84	17.92	1.15	1.71	1.62	1.64
600	5.34	5.30	5.42	0.12	1.62	18.12	16.89	18.07	1.18	1.69	1.58	1.61
625	5.37	5.32	5.45	0.13	1.66	18.19	16.91	18.14	1.19	1.67	1.56	1.59
650	5.39	5.33	5.48	0.15	1.71	18.23	16.90	18.17	1.21	1.66	1.54	1.58
675	5.42	5.35	5.51	0.16	1.73	18.27	16.88	18.20	1.23	1.64	1.52	1.56
700	5.45	5.37	5.55	0.18	1.79	18.27	16.84	18.20	1.25	1.63	1.49	1.54
725	5.48	5.39	5.59	0.19	1.83	18.27	16.80	18.19	1.27	1.61	1.47	1.52
750	5.51	5.42	5.62	0.21	1.86	18.25	16.75	18.17	1.29	1.60	1.45	1.50
775	5.54	5.45	5.67	0.22	1.89	18.22	16.70	18.14	1.31	1.58	1.43	1.48
800	5.58	5.47	5.71	0.24	1.91	18.19	16.64	18.10	1.33	1.56	1.41	1.46
825	5.62	5.50	5.76	0.26	1.94	18.13	16.56	18.04	1.35	1.54	1.39	1.45
850	5.66	5.53	5.80	0.27	1.98	18.08	16.49	17.99	1.38	1.53	1.37	1.43
875	5.70	5.57	5.85	0.29	2.02	18.00	16.40	17.91	1.40	1.51	1.35	1.41
900	5.74	5.60	5.90	0.30	2.03	17.94	16.32	17.85	1.42	1.49	1.33	1.40
925	5.78	5.63	5.96	0.33	2.04	17.86	16.23	17.78	1.44	1.48	1.31	1.38
940	5.81	5.65	5.99	0.33	2.07	17.82	16.19	17.75	1.45	1.46	1.29	1.37
950	5.83	5.66	6.01	0.35	2.06	17.81	16.16	17.73	1.46	1.46	1.29	1.37
975	5.87	5.70	6.07	0.36	2.10	17.74	16.08	17.67	1.48	1.44	1.27	1.35
1000	5.92	5.74	6.12	0.38	2.13	17.68	16.01	17.62	1.49	1.42	1.25	1.34
1025	5.97	5.77	6.18	0.41	2.13	17.64	15.95	17.58	1.51	1.41	1.23	1.32
1050	6.02	5.81	6.24	0.43	2.14	17.60	15.90	17.55	1.52	1.39	1.22	1.31
1100	6.11	5.88	6.35	0.47	2.14	17.58	15.81	17.53	1.54	1.36	1.19	1.28
1200	6.31	6.02	6.60	0.58	2.10	17.75	15.79	17.71	1.54	1.30	1.15	1.23
1300	6.51	6.16	6.87	0.71	1.92	18.34	16.05	18.28	1.46	1.26	1.12	1.20
1400	6.77	6.34	7.22	0.87	1.55	19.49	16.63	19.33	1.34	1.24	1.11	1.18
1500	7.22	6.69	7.76	1.07	0.89	21.20	17.55	20.79	1.30	1.25	1.13	1.19
1600	8.04	7.36	8.70	1.33	0.59	22.28	18.37	21.59	1.58	1.29	1.17	1.21
1700	9.41	8.54	10.21	1.67	1.92	20.80	18.21	20.35	2.17	1.33	1.25	1.24

¹ Total Loss = Insertion Loss+ 4.8dB Splitter Loss



3 Way-0° Power Splitter/Combiner

SCA-3-11+

Typical Performance Data

TEST CONDITIONS: INPUT POWER = 0dBm @Temperature = -45°C

FREQ. (MHz)	TOTAL LOSS ¹ (dB)			AMP. UNBAL. (dB)	PHASE UNBAL. (deg.)	ISOLATION (dB)			VSWR (:1)			
	S-1	S-2	S-3			1-2	1-3	2-3	S	1	2	3
20	7.01	7.06	7.05	0.05	0.21	18.67	18.84	18.76	3.72	2.82	2.80	2.80
50	5.54	5.56	5.57	0.03	0.26	17.90	17.84	17.97	1.81	1.94	1.94	1.95
60	5.44	5.46	5.47	0.03	0.35	17.86	17.78	17.93	1.66	1.88	1.88	1.88
70	5.38	5.40	5.40	0.02	0.41	17.85	17.74	17.90	1.55	1.84	1.84	1.83
80	5.34	5.36	5.35	0.02	0.45	17.85	17.72	17.88	1.48	1.82	1.82	1.80
90	5.31	5.33	5.30	0.02	0.45	17.85	17.70	17.87	1.42	1.81	1.81	1.78
100	5.28	5.30	5.28	0.02	0.44	17.84	17.68	17.87	1.38	1.80	1.80	1.76
110	5.26	5.29	5.25	0.04	0.43	17.83	17.65	17.86	1.34	1.78	1.79	1.75
120	5.24	5.27	5.24	0.04	0.45	17.82	17.63	17.85	1.31	1.76	1.78	1.74
130	5.22	5.26	5.24	0.04	0.51	17.82	17.62	17.85	1.29	1.74	1.76	1.73
140	5.21	5.25	5.23	0.04	0.54	17.80	17.60	17.85	1.27	1.73	1.75	1.72
150	5.21	5.25	5.23	0.04	0.61	17.79	17.58	17.84	1.26	1.73	1.74	1.72
200	5.19	5.23	5.20	0.03	0.85	17.78	17.49	17.79	1.21	1.73	1.73	1.69
225	5.18	5.22	5.21	0.05	0.87	17.75	17.44	17.78	1.19	1.71	1.71	1.69
250	5.17	5.21	5.22	0.05	1.16	17.73	17.40	17.78	1.18	1.69	1.69	1.69
275	5.17	5.20	5.22	0.05	1.38	17.74	17.38	17.78	1.17	1.69	1.67	1.68
300	5.17	5.19	5.21	0.05	1.47	17.77	17.36	17.79	1.15	1.70	1.67	1.67
325	5.16	5.20	5.22	0.06	1.62	17.82	17.36	17.84	1.13	1.69	1.66	1.66
350	5.16	5.19	5.23	0.07	1.79	17.90	17.40	17.93	1.12	1.67	1.64	1.65
375	5.16	5.19	5.24	0.07	2.02	17.98	17.44	18.00	1.12	1.67	1.63	1.64
400	5.17	5.19	5.23	0.06	2.18	18.09	17.50	18.10	1.11	1.67	1.63	1.63
425	5.17	5.20	5.24	0.07	2.26	18.20	17.55	18.21	1.11	1.66	1.63	1.62
450	5.17	5.20	5.25	0.08	2.38	18.30	17.59	18.30	1.11	1.65	1.61	1.61
475	5.19	5.20	5.27	0.08	2.53	18.38	17.63	18.37	1.11	1.65	1.59	1.59
500	5.20	5.20	5.28	0.08	2.64	18.45	17.66	18.44	1.12	1.64	1.57	1.58
525	5.21	5.21	5.30	0.09	2.76	18.54	17.69	18.52	1.13	1.64	1.56	1.56
550	5.23	5.22	5.32	0.10	2.91	18.60	17.71	18.58	1.14	1.63	1.54	1.55
600	5.26	5.24	5.36	0.12	3.10	18.70	17.71	18.67	1.17	1.60	1.51	1.52
625	5.28	5.25	5.39	0.13	3.21	18.76	17.73	18.72	1.18	1.59	1.49	1.51
650	5.29	5.26	5.42	0.15	3.36	18.78	17.71	18.73	1.20	1.58	1.47	1.49
675	5.32	5.28	5.44	0.16	3.48	18.80	17.68	18.74	1.21	1.56	1.45	1.47
700	5.34	5.30	5.48	0.18	3.58	18.77	17.63	18.72	1.24	1.55	1.43	1.45
725	5.37	5.32	5.51	0.19	3.78	18.74	17.57	18.67	1.26	1.54	1.41	1.44
750	5.40	5.34	5.55	0.21	3.90	18.68	17.49	18.61	1.28	1.52	1.39	1.42
775	5.43	5.37	5.59	0.23	3.98	18.59	17.39	18.52	1.31	1.51	1.37	1.41
800	5.46	5.40	5.64	0.24	4.08	18.50	17.29	18.44	1.33	1.49	1.35	1.39
825	5.49	5.43	5.68	0.26	4.19	18.39	17.16	18.32	1.35	1.47	1.33	1.38
850	5.53	5.45	5.73	0.28	4.32	18.30	17.06	18.24	1.38	1.46	1.31	1.36
875	5.57	5.47	5.77	0.30	4.41	18.18	16.94	18.12	1.40	1.45	1.29	1.35
900	5.59	5.50	5.81	0.31	4.54	18.10	16.84	18.05	1.42	1.44	1.28	1.33
925	5.63	5.53	5.87	0.34	4.63	17.99	16.73	17.95	1.44	1.42	1.26	1.32
940	5.65	5.55	5.89	0.35	4.71	17.96	16.67	17.92	1.45	1.40	1.25	1.31
950	5.66	5.55	5.92	0.36	4.80	17.93	16.64	17.89	1.46	1.40	1.24	1.30
975	5.71	5.59	5.97	0.38	4.90	17.84	16.54	17.81	1.48	1.38	1.22	1.29
1000	5.75	5.62	6.03	0.41	5.05	17.78	16.46	17.76	1.50	1.37	1.21	1.28
1025	5.79	5.66	6.08	0.42	5.21	17.72	16.37	17.69	1.52	1.36	1.19	1.26
1050	5.83	5.69	6.14	0.44	5.33	17.68	16.31	17.64	1.53	1.34	1.17	1.25
1100	5.93	5.76	6.26	0.50	5.52	17.61	16.18	17.58	1.56	1.31	1.14	1.23
1200	6.10	5.89	6.50	0.61	6.18	17.72	16.11	17.67	1.57	1.26	1.11	1.19
1300	6.28	6.02	6.77	0.75	6.77	18.23	16.32	18.15	1.51	1.22	1.09	1.16
1400	6.51	6.19	7.12	0.93	7.68	19.24	16.82	19.01	1.39	1.19	1.08	1.14
1500	6.92	6.51	7.65	1.14	8.86	20.73	17.63	20.21	1.33	1.21	1.11	1.15
1600	7.69	7.15	8.56	1.41	10.24	21.43	18.24	20.68	1.55	1.25	1.15	1.17
1700	9.02	8.31	10.06	1.75	12.06	19.80	17.80	19.43	2.14	1.31	1.23	1.20

¹ Total Loss = Insertion Loss+ 4.8dB Splitter Loss



3 Way-0° Power Splitter/Combiner

SCA-3-11+

Typical Performance Data

TEST CONDITIONS: INPUT POWER = 0dBm @Temperature = +85°C

FREQ. (MHz)	TOTAL LOSS ¹ (dB)			AMP. UNBAL. (dB)	PHASE UNBAL. (deg.)	ISOLATION (dB)			VSWR (:1)			
	S-1	S-2	S-3			1-2	1-3	2-3	S	1	2	3
20	6.90	6.94	6.90	0.05	0.19	15.87	15.77	15.93	3.68	3.02	3.03	2.98
50	5.51	5.53	5.47	0.07	0.56	15.28	15.07	15.29	1.78	2.36	2.37	2.31
60	5.41	5.44	5.38	0.07	0.78	15.23	15.02	15.25	1.62	2.30	2.31	2.25
70	5.34	5.38	5.33	0.05	0.93	15.20	14.98	15.23	1.52	2.24	2.26	2.22
80	5.29	5.34	5.30	0.05	0.98	15.17	14.96	15.22	1.44	2.20	2.22	2.19
90	5.27	5.31	5.29	0.04	1.00	15.15	14.94	15.21	1.40	2.16	2.18	2.17
100	5.24	5.28	5.28	0.04	0.99	15.14	14.94	15.22	1.36	2.14	2.16	2.16
110	5.23	5.27	5.27	0.03	1.01	15.15	14.94	15.23	1.33	2.12	2.13	2.15
120	5.23	5.26	5.26	0.03	0.95	15.17	14.94	15.24	1.30	2.12	2.12	2.14
130	5.22	5.25	5.24	0.03	0.95	15.20	14.96	15.26	1.27	2.12	2.12	2.12
140	5.22	5.24	5.23	0.03	1.02	15.24	14.97	15.29	1.25	2.12	2.11	2.11
150	5.21	5.25	5.22	0.04	1.14	15.27	14.98	15.32	1.23	2.11	2.11	2.10
200	5.17	5.23	5.22	0.06	1.67	15.42	15.05	15.49	1.15	2.03	2.04	2.05
225	5.18	5.22	5.22	0.04	1.78	15.55	15.15	15.61	1.13	2.02	2.01	2.03
250	5.19	5.22	5.21	0.03	1.83	15.71	15.24	15.74	1.11	2.02	1.99	2.00
275	5.19	5.23	5.21	0.05	2.14	15.86	15.32	15.88	1.09	1.99	1.98	1.98
300	5.18	5.23	5.22	0.05	2.45	15.98	15.38	16.00	1.08	1.96	1.95	1.95
325	5.20	5.23	5.23	0.03	2.64	16.12	15.47	16.12	1.08	1.95	1.91	1.93
350	5.22	5.23	5.23	0.02	2.79	16.28	15.56	16.26	1.08	1.95	1.89	1.91
375	5.23	5.23	5.25	0.02	3.01	16.42	15.62	16.38	1.08	1.93	1.87	1.89
400	5.23	5.24	5.26	0.03	3.25	16.55	15.69	16.52	1.08	1.91	1.85	1.86
425	5.25	5.25	5.28	0.03	3.51	16.69	15.76	16.64	1.09	1.89	1.82	1.84
450	5.27	5.25	5.30	0.05	3.71	16.83	15.83	16.76	1.10	1.88	1.79	1.82
475	5.29	5.25	5.32	0.06	3.89	16.96	15.88	16.88	1.11	1.87	1.77	1.80
500	5.30	5.26	5.34	0.08	4.05	17.08	15.94	17.00	1.12	1.85	1.75	1.78
525	5.32	5.28	5.37	0.09	4.22	17.20	15.99	17.12	1.13	1.82	1.72	1.76
550	5.35	5.29	5.40	0.11	4.39	17.32	16.04	17.23	1.15	1.81	1.69	1.74
600	5.39	5.33	5.46	0.13	4.75	17.54	16.11	17.42	1.18	1.77	1.65	1.70
625	5.42	5.35	5.49	0.15	4.89	17.63	16.15	17.51	1.20	1.75	1.62	1.68
650	5.45	5.37	5.53	0.16	5.07	17.70	16.15	17.56	1.22	1.73	1.60	1.66
675	5.48	5.39	5.56	0.17	5.20	17.76	16.15	17.61	1.23	1.71	1.57	1.64
700	5.52	5.41	5.60	0.19	5.33	17.79	16.14	17.64	1.26	1.69	1.55	1.62
725	5.55	5.44	5.64	0.20	5.45	17.82	16.12	17.65	1.27	1.68	1.53	1.60
750	5.59	5.47	5.68	0.21	5.59	17.84	16.10	17.66	1.30	1.65	1.50	1.57
775	5.63	5.50	5.73	0.23	5.75	17.82	16.07	17.65	1.32	1.63	1.48	1.56
800	5.67	5.53	5.77	0.24	5.91	17.83	16.04	17.65	1.34	1.62	1.46	1.53
825	5.71	5.56	5.82	0.25	6.05	17.79	15.98	17.61	1.36	1.60	1.44	1.52
850	5.75	5.59	5.86	0.27	6.25	17.78	15.95	17.60	1.38	1.58	1.42	1.50
875	5.80	5.63	5.91	0.28	6.40	17.72	15.88	17.55	1.40	1.56	1.40	1.48
900	5.84	5.66	5.96	0.30	6.56	17.70	15.83	17.54	1.42	1.54	1.38	1.46
925	5.88	5.69	6.01	0.32	6.70	17.64	15.77	17.50	1.44	1.53	1.36	1.45
940	5.91	5.71	6.04	0.33	6.75	17.63	15.74	17.49	1.45	1.52	1.35	1.44
950	5.92	5.72	6.06	0.34	6.78	17.63	15.73	17.48	1.45	1.51	1.34	1.43
975	5.98	5.76	6.12	0.35	6.95	17.59	15.68	17.45	1.47	1.49	1.32	1.42
1000	6.02	5.80	6.17	0.37	7.12	17.57	15.64	17.45	1.48	1.48	1.30	1.40
1025	6.08	5.84	6.23	0.39	7.19	17.56	15.61	17.43	1.49	1.46	1.29	1.39
1050	6.13	5.88	6.28	0.40	7.35	17.55	15.59	17.44	1.50	1.44	1.27	1.37
1100	6.22	5.95	6.39	0.44	7.56	17.58	15.54	17.48	1.51	1.41	1.24	1.34
1200	6.42	6.08	6.62	0.54	8.02	17.84	15.61	17.75	1.49	1.35	1.20	1.30
1300	6.63	6.23	6.89	0.66	8.58	18.48	15.92	18.42	1.40	1.31	1.17	1.26
1400	6.90	6.43	7.23	0.80	9.14	19.69	16.53	19.56	1.29	1.29	1.15	1.23
1500	7.37	6.79	7.78	0.99	9.54	21.55	17.51	21.27	1.29	1.29	1.16	1.23
1600	8.19	7.47	8.71	1.24	9.73	23.14	18.55	22.55	1.59	1.31	1.19	1.25
1700	9.51	8.62	10.19	1.57	9.59	22.07	18.82	21.58	2.18	1.35	1.26	1.27

¹ Total Loss = Insertion Loss+ 4.8dB Splitter Loss



3 Way-0° Power Splitter/Combiner

SCA-3-11+

Typical Performance Curves

Total Loss

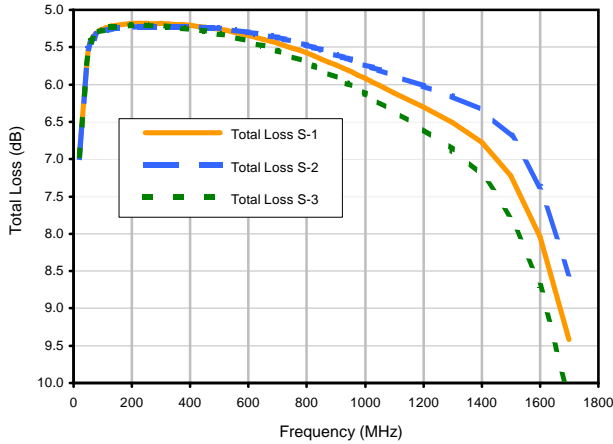

Total Loss S-1 vs. TEMPERATURE

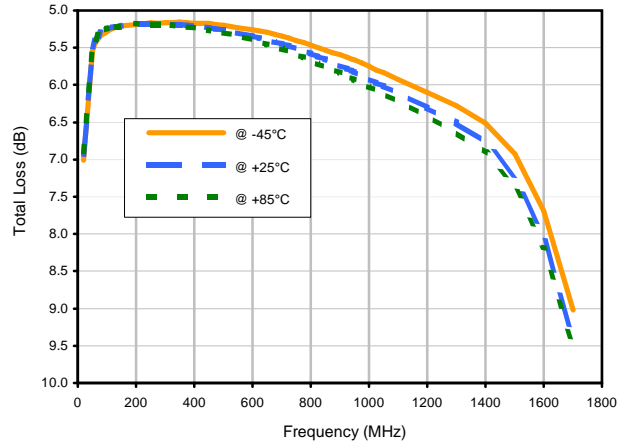

Amplitude Unbalance vs. TEMPERATURE

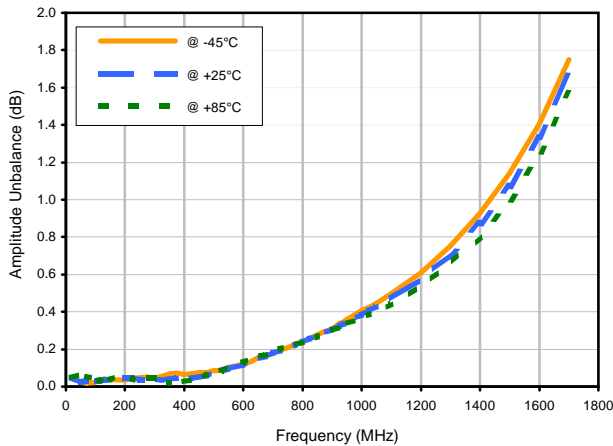

Phase Unbalance vs. TEMPERATURE

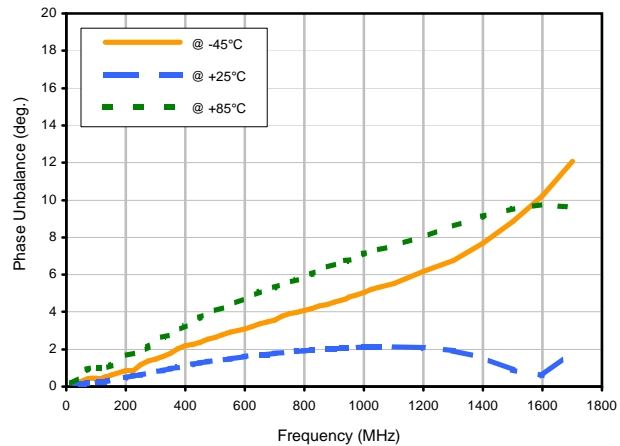

Isolation

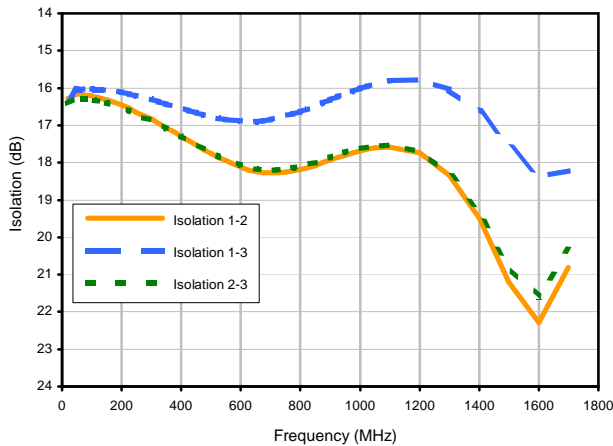

Isolation 1-2 vs. TEMPERATURE

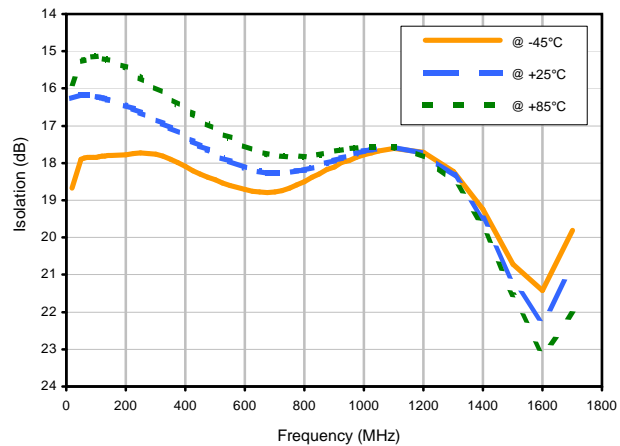

REV. X2
SCA-3-11+
100627
Page 1 of 2



RF/MICROWAVE COMPONENTS • ISO 9001 ISO 14001 AS 9100 CERTIFIED • RoHS compliant
P.O. Box 350166, Brooklyn, New York 11235-0006 (718) 934-4500 Fax (718) 332-4661



The Design Engineers Search Engine finds the model you need, Instantly • For detailed performance specs & shopping online see



3 Way-0° Power Splitter/Combiner

SCA-3-11+

Typical Performance Curves

VSWR

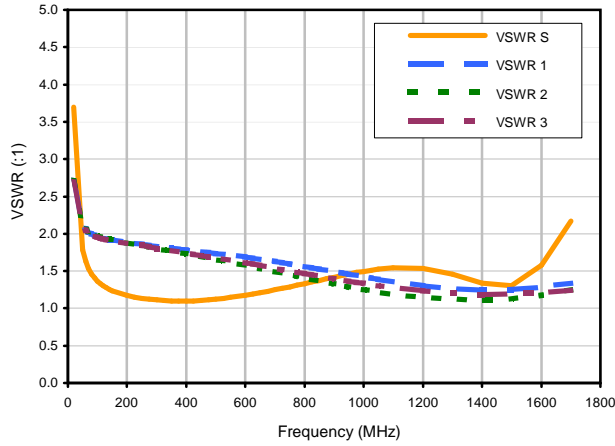

VSWR SUM vs. TEMPERATURE

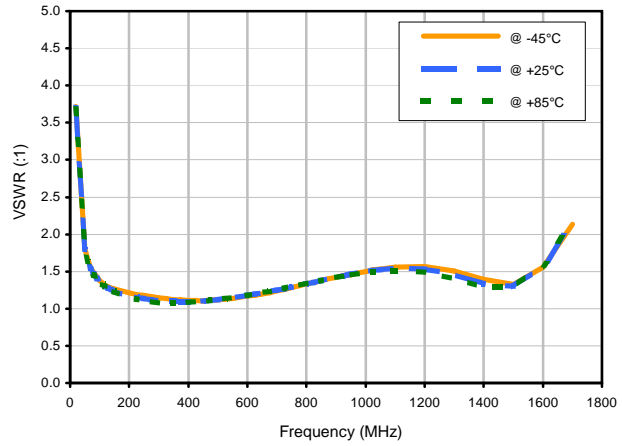

VSWR OUT1 vs. TEMPERATURE

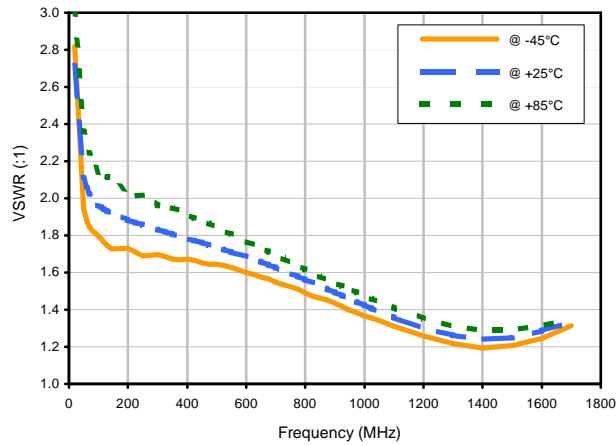

REV. X2
SCA-3-11+
100627
Page 2 of 2



RF/MICROWAVE COMPONENTS • ISO 9001 ISO 14001 AS 9100 CERTIFIED • RoHS compliant
P.O. Box 350166, Brooklyn, New York 11235-0003 (718) 934-4500 Fax (718) 332-4661



The Design Engineers Search Engine finds the model you need, Instantly • For detailed performance specs & shopping online see



Outline Dimensions

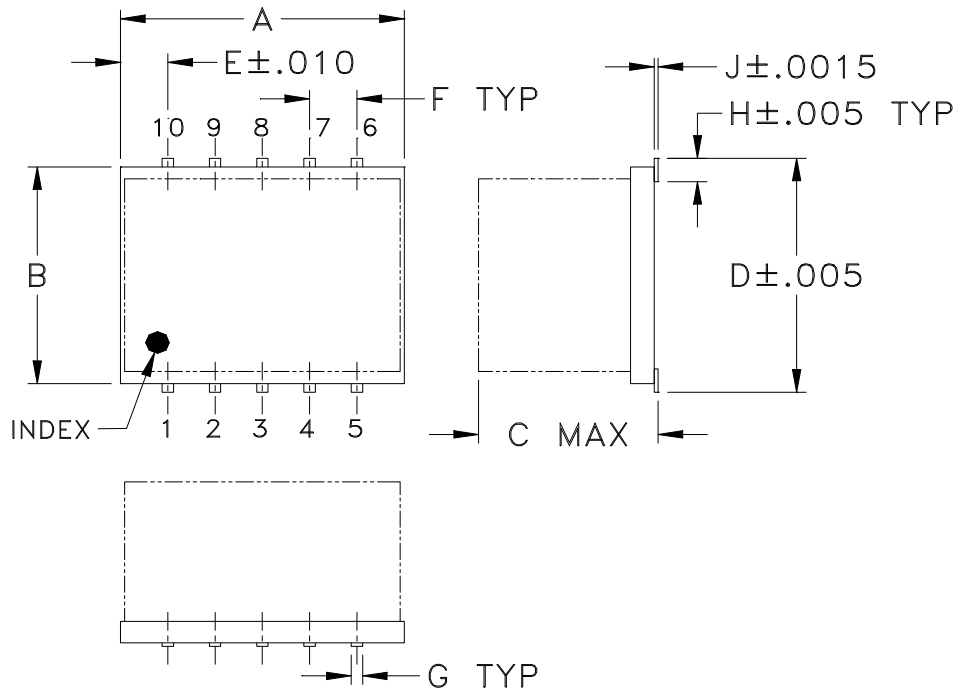

PCB Land Pattern

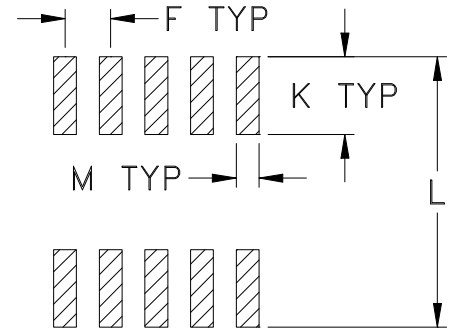

Suggested Layout,
Tolerance to be within $\pm.002$

CASE#	A	B	C	D	E	F	G	H	J	K	L	M	WT. GRAMS
DZ943	.30 (7.62)	.250 (6.35)	.190 (4.83)	.266 (6.76)	.050 (1.27)	.050 (1.27)	.012 (0.30)	.029 (0.74)	.004 (0.10)	.085 (2.16)	.296 (7.52)	.030 (0.76)	0.5

Dimensions are in inches (mm). Tolerances: 2Pl. $\pm .01$; 3Pl. $\pm .005$

Notes:

- Case material: Plastic.
- Base: Ceramic.
- Termination finish:
 - For RoHS Case Styles: Tin plate. All models, (+) suffix.
 - For RoHS-5 Case Styles: Tin-Lead plate. All models, no (+) suffix.



INTERNET <http://www.minicircuits.com>

P.O. Box 350166, Brooklyn, New York 11235-0003 (718) 934-4500 Fax (718) 332-4661

Distribution Centers NORTH AMERICA 800-654-7949 • 417-335-5935 • Fax 417-335-5945 • EUROPE 44-1252-832600 • Fax 44-1252-837010

Mini-Circuits ISO 9001 & ISO 14001 Certified

Tape & Reel Packaging TR-F34

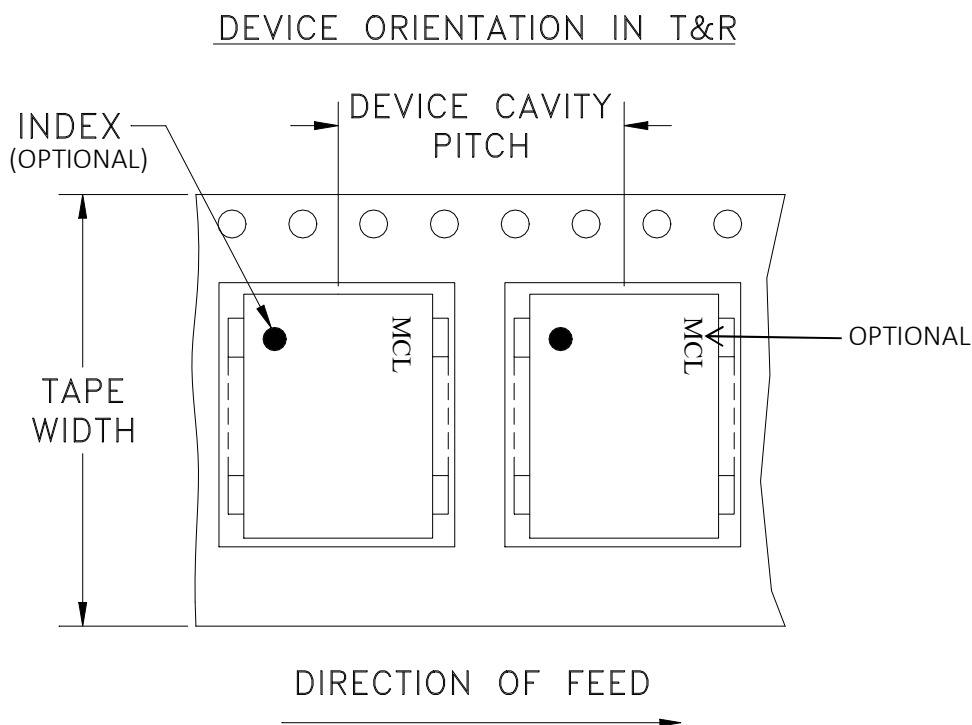

Tape Width, mm	Device Cavity Pitch, mm	Reel Size, inches	Devices per Reel see note	
16	12	7	Small quantity standard (see note)	20
				50
				100
				200
		13	Standard	500
				1000

Note: Availability of small reel quantity varies by model.
Refer to pricing and availability on individual model dashboard.

Mini-Circuits carrier tape materials provide protection from ESD (Electro-Static Discharge) during handling and transportation. Tapes are static dissipative and comply with industry standards EIA-481/EIA-541.

Go to: www.minicircuits.com/pages/pdfs/tape.pdf



INTERNET <http://www.minicircuits.com>

P.O. Box 350166, Brooklyn, New York 11235-0003 (718) 934-4500 Fax (718) 332-4661

Distribution Centers NORTH AMERICA 800-654-7949 • 417-335-5935 • Fax 417-335-5945 • EUROPE 44-1252-832600 • Fax 44-1252-837010

Mini-Circuits ISO 9001 & ISO 14001 Certified

THIRD ANGLE PROJECTION

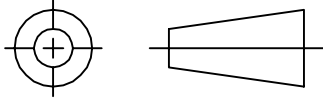

REVISIONS

REV	ECN No.	DESCRIPTION	DATE	DR	AUTH
OR	M89258	NEW RELEASE	11/13/03	AV	LC
A	M102713	ADDED "...WITH SMOBC"	01/12/06	GF	IL

SUGGESTED MOUNTING CONFIGURATION
FOR DZ943 CASE STYLE, "pc" PIN CONNECTION.

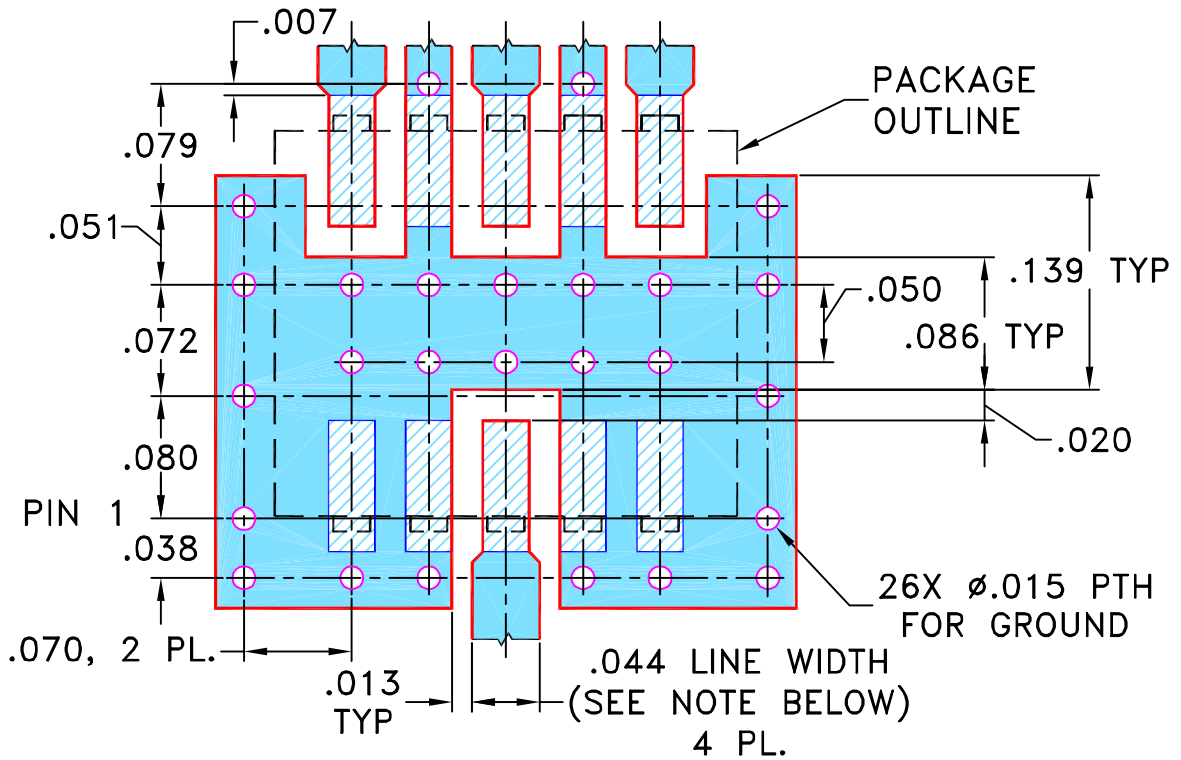

- NOTE: 1. TRACE WIDTH IS SHOWN FOR ROGERS R04350B WITH DIELECTRIC THICKNESS 0.020" ± 0.0015"; COPPER: 1/2 OZ. EACH SIDE. FOR OTHER MATERIALS TRACE WIDTH MAY NEED TO BE MODIFIED.
2. BOTTOM SIDE OF THE PCB IS CONTINUOUS GROUND PLANE.

- DENOTES PCB COPPER LAYOUT WITH SMOBC (SOLDER MASK OVER BARE COPPER)
- DENOTES COPPER LAND PATTERN FREE OF SOLDER MASK

UNLESS OTHERWISE SPECIFIED	INITIALS	DATE
DIMENSIONS ARE IN INCHES TOLERANCES ON: 2 PL DECIMALS ± 3 PL DECIMALS ± .005 ANGLES ± FRACTIONS ±	DRAWN	AV 09/10/03
	CHECKED	IL 11/12/03
	APPROVED	LC 11/13/03

Mini-Circuits® 13 Neptune Avenue
Brooklyn NY 11235

PL, pc, DZ943, SCA-3, TB-246

Mini-Circuits®
THIS DOCUMENT AND ITS CONTENTS ARE THE PROPERTY OF MINI-CIRCUITS. EXCEPT FOR USE EXPRESSLY GRANTED, IN WRITING, TO ITS VENDORS, VENDEE AND THE UNITED STATES GOVERNMENT, MINI-CIRCUITS RESERVES ALL PROPRIETARY DESIGN, USE, MANUFACTURING AND REPRODUCTION RIGHTS THERETO. THESE CONTENTS SHALL NOT BE USED, DUPLICATED OR DISCLOSED TO ANY OUTSIDE PARTY, IN WHOLE OR IN PART, WITHOUT WRITTEN PERMISSION OF MINI-CIRCUITS.

SIZE A	CODE IDENT 15542	DRAWING NO: 98-PL-144	REV: A
FILE: 98PL144	SCALE: 8:1	SHEET: 1 OF 1	

Evaluation Board and Circuit

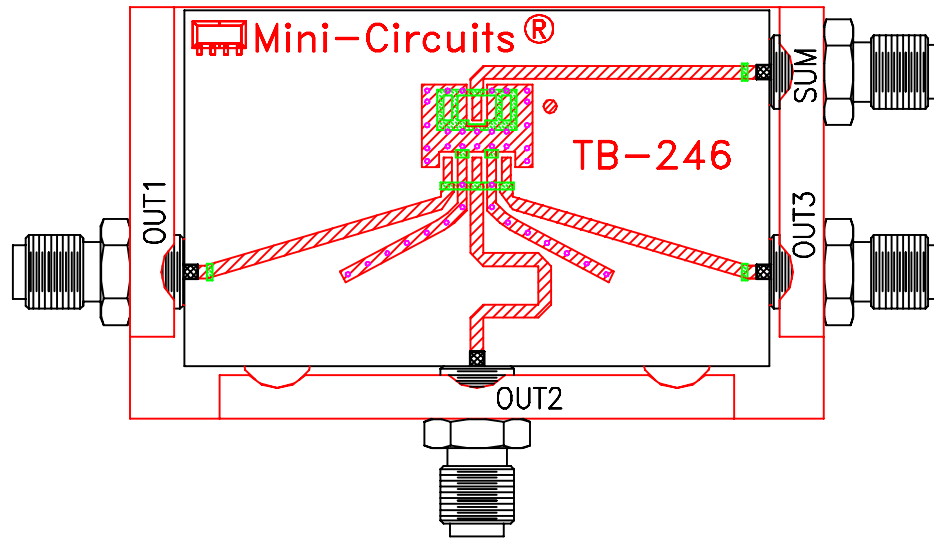

TB-246

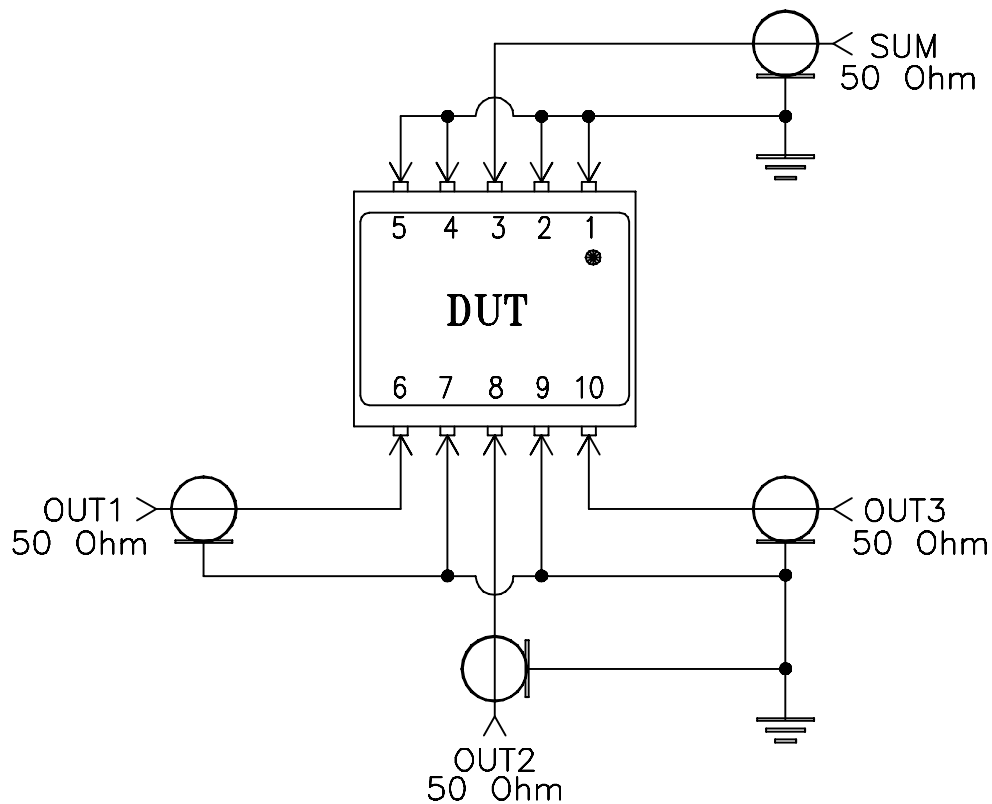

Schematic Diagram

Notes:

1. SMA Female connectors.
2. PCB Material: Rogers RO4350 or equivalent,
Dielectric Constant=3.5, Thickness=.020 inch.

 Mini-Circuits®

All Mini-Circuits products are manufactured under exacting quality assurance and control standards, and are capable of meeting published specifications after being subjected to any or all of the following physical and environmental test.

Specification	Test/Inspection Condition	Reference/Spec
Operating Temperature	-40° to 85°C Ambient Environment	Individual Model Data Sheet
Storage Temperature	-55° to 100° C Ambient Environment	Individual Model Data Sheet
Thermal Shock	-55° to 100°C, 100 cycles	MIL-STD-202, Method 107, Condition A-3, except +100°C
Vibration (High Frequency)	20g peak, 10-2000 Hz, 12 times in each of three perpendicular directions (total 36)	MIL-STD-202, Method 204, Condition D
Mechanical Shock	50g, 11 ms, 1/2-sine, 18 shocks: 3 each direction, each of 3 axes	MIL-STD-202, Method 213, Condition A
Autoclave	15 psig, 100% RH, 121°C, 96 hours	JESD22-A102-C, Condition C
Solderability	10X Magnification	J-STD-002, Para 4.2.5, Test S, 95% Coverage
Solder Reflow Heat	Sn-Pb Eutectic Process: 225°C peak Pb-Free Process: 250°C peak	J-STD-020, Table 4-1, 4-2 and 5-2; Figure 5-1
Marking Resistance to Solvents	Isopropyl alcohol + mineral spirits at 25°C; terpene defluxer at 25°C; distilled water + proylene glycol monomethyl ether + monoethanolamine at 63°C to 70°C	MIL-STD-202, Method 215