

Engineering Development Model

Power Splitter/Combiner 4 Way-0°

SCA-ED14456/1

Important Note

This model has been designed, built and tested in our engineering department. Performance data represents model capability. At present it is a non-catalog model. On request, we can supply a final specification sheet, part number and price/delivery information.



Please click "Back", and then click "Contact Us" for Applications support.

CASE STYLE : DZ943

ELECTRICAL SPECIFICATIONS 75Ω @ +25°C					
Parameter		Min.	Typ.	Max.	Units
Frequency		10		2150	MHz
Isolation	10-100 MHz		19		dB
	100-1000 MHz		20		dB
	1000-2150 MHz		17		dB
Insertion Loss Above 6.0 dB	10-100 MHz		2.5		dB
	100-1000 MHz		1.8		dB
	1000-2150 MHz		4.7		dB
Phase Unbalance	10-2150 MHz		10		deg.
Amplitude Unbalance	10-2150 MHz		1.0		dB
VSWR	SUM Port		1.95		(:1)
	OUT Ports		2.00		(:1)

MAXIMUM RATINGS	
Operating Temperature	-40°C to 85°C
Storage Temperature	-55°C to 100°C

PIN CONNECTIONS	
SUM PORT	3
PORT 1	6
PORT 2	7
PORT 3	9
PORT 4	10
GROUND	1,2,4,5,8

Functional Diagram



4 Way-0° Power Splitter/Combiner

SCA-ED14456/1

Typical Performance Data

FREQ. (MHz)	TOTAL LOSS ¹ (dB)				AMP. UNBAL. (dB)	ISOLATION (dB)			PHASE UNBAL. (deg.)	FREQ. (MHz)	VSWR (:1)				
	S-1	S-2	S-3	S-4		1-2	2-3	3-4			S	1	2	3	4
10.0	7.25	7.49	8.16	7.94	0.91	18.22	58.83	18.30	5.58	10.0	1.98	1.89	1.77	2.02	2.19
20.0	7.11	7.35	7.87	7.65	0.76	19.18	52.47	20.12	3.23	20.0	1.58	1.73	1.64	1.77	1.89
30.0	6.99	7.23	7.69	7.48	0.70	19.14	49.96	20.25	2.44	30.0	1.45	1.67	1.59	1.69	1.79
50.0	6.89	7.13	7.53	7.31	0.64	19.02	46.92	20.19	1.66	50.0	1.34	1.62	1.54	1.62	1.71
70.0	6.84	7.08	7.46	7.25	0.61	18.98	45.10	20.11	1.27	70.0	1.30	1.59	1.52	1.59	1.67
90.0	6.82	7.06	7.42	7.21	0.60	18.96	43.77	20.05	1.05	90.0	1.27	1.57	1.50	1.57	1.65
100.0	6.81	7.05	7.41	7.19	0.59	18.96	43.22	20.04	0.96	100.0	1.27	1.57	1.50	1.56	1.64
200.0	6.83	7.06	7.40	7.19	0.56	19.36	39.51	20.32	0.50	200.0	1.32	1.55	1.50	1.55	1.62
300.0	6.88	7.09	7.43	7.22	0.55	20.13	36.65	20.99	0.33	300.0	1.44	1.57	1.54	1.57	1.62
400.0	6.93	7.12	7.45	7.26	0.52	21.21	34.23	21.88	0.24	400.0	1.57	1.60	1.59	1.61	1.63
500.0	6.97	7.14	7.46	7.29	0.49	22.55	32.11	22.86	0.16	500.0	1.68	1.63	1.64	1.66	1.65
600.0	7.02	7.17	7.47	7.31	0.45	24.17	30.35	23.86	0.06	600.0	1.76	1.66	1.69	1.70	1.67
700.0	7.10	7.22	7.51	7.37	0.41	26.24	28.99	25.05	0.16	700.0	1.80	1.69	1.73	1.74	1.68
800.0	7.21	7.32	7.59	7.45	0.38	28.78	27.87	26.34	0.37	800.0	1.80	1.71	1.77	1.77	1.69
900.0	7.36	7.45	7.71	7.57	0.35	32.32	27.10	28.02	0.62	900.0	1.76	1.73	1.80	1.80	1.70
950.0	7.44	7.52	7.78	7.64	0.33	34.78	26.79	29.02	0.74	950.0	1.72	1.75	1.81	1.81	1.70
1000.0	7.53	7.61	7.85	7.72	0.32	38.41	26.65	30.36	0.87	1000.0	1.68	1.76	1.83	1.83	1.71
1100.0	7.71	7.77	8.01	7.86	0.30	63.27	26.50	34.15	1.11	1100.0	1.59	1.78	1.86	1.87	1.72
1200.0	7.87	7.91	8.15	7.99	0.29	36.39	26.70	43.69	1.33	1200.0	1.50	1.81	1.89	1.91	1.75
1250.0	7.94	7.98	8.22	8.05	0.28	32.88	26.97	50.95	1.42	1250.0	1.46	1.83	1.91	1.93	1.76
1300.0	8.00	8.03	8.28	8.10	0.28	30.16	27.13	40.17	1.53	1300.0	1.42	1.84	1.92	1.95	1.78
1400.0	8.14	8.15	8.40	8.20	0.26	26.31	27.76	31.34	1.64	1400.0	1.33	1.87	1.95	1.98	1.81
1500.0	8.31	8.31	8.56	8.34	0.25	23.55	28.39	26.86	1.71	1500.0	1.27	1.88	1.95	2.00	1.85
1600.0	8.57	8.56	8.80	8.57	0.24	21.55	28.66	24.00	1.77	1600.0	1.25	1.89	1.95	2.01	1.88
1700.0	8.93	8.90	9.14	8.91	0.23	20.07	28.39	21.97	1.75	1700.0	1.29	1.88	1.92	2.01	1.91
1800.0	9.36	9.31	9.53	9.30	0.23	19.02	27.43	20.54	1.71	1800.0	1.38	1.86	1.89	2.02	1.92
1900.0	9.78	9.70	9.91	9.69	0.23	18.27	25.98	19.47	1.66	1900.0	1.46	1.82	1.84	2.02	1.92
2000.0	10.13	10.04	10.21	9.97	0.24	17.74	24.33	18.64	1.44	2000.0	1.55	1.76	1.79	2.01	1.90
2100.0	10.43	10.31	10.44	10.17	0.27	17.42	22.74	18.09	1.26	2100.0	1.64	1.69	1.74	1.99	1.83
2150.0	10.57	10.44	10.52	10.23	0.34	17.36	22.10	17.91	1.09	2150.0	1.69	1.66	1.72	1.99	1.78
2200.0	10.67	10.55	10.58	10.26	0.41	17.38	21.49	17.77	1.19	2200.0	1.74	1.64	1.72	1.98	1.73

¹Total Loss = Insertion Loss + 6dB Splitter Loss



4 Way-0° Power Splitter/Combiner

SCA-ED14456/1

Typical Performance Curves

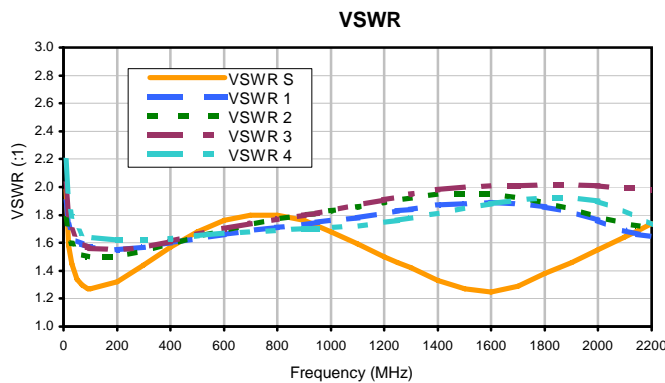
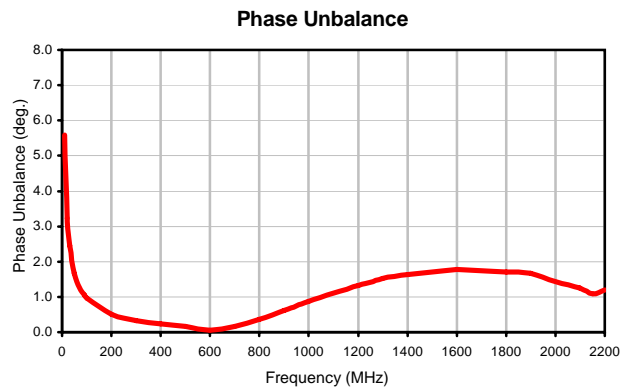
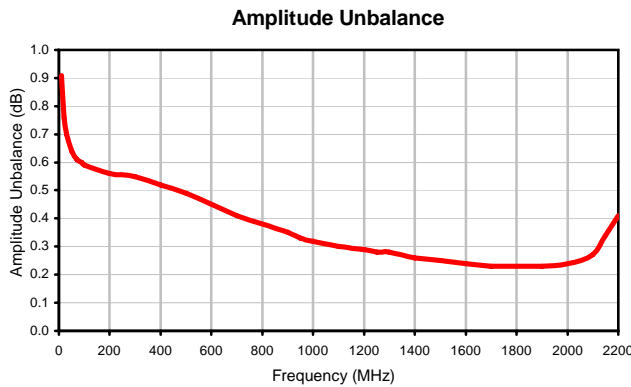
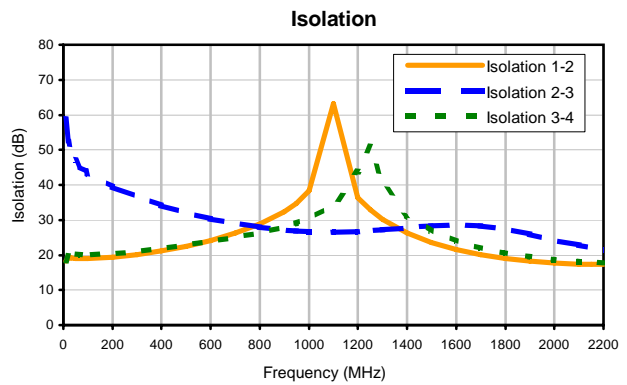
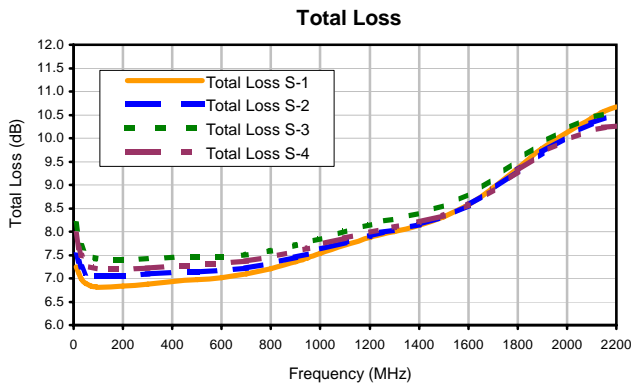

Outline Dimensions

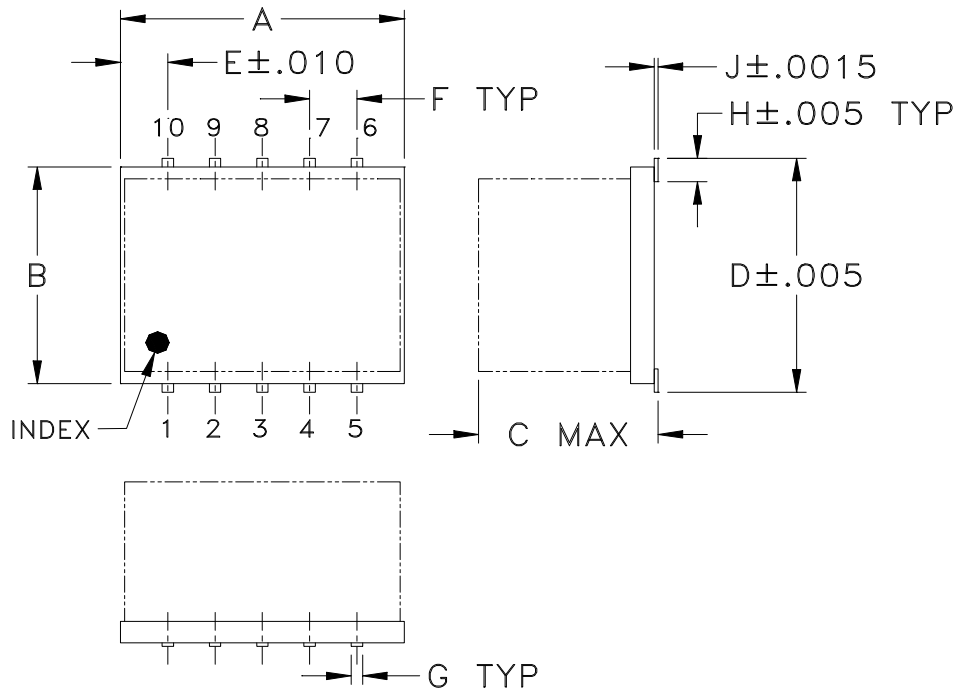

PCB Land Pattern

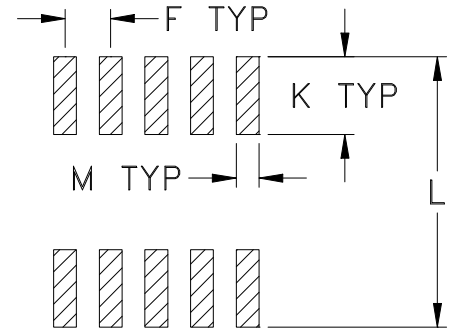

Suggested Layout,
Tolerance to be within $\pm.002$

CASE#	A	B	C	D	E	F	G	H	J	K	L	M	WT. GRAMS
DZ943	.30 (7.62)	.250 (6.35)	.190 (4.83)	.266 (6.76)	.050 (1.27)	.050 (1.27)	.012 (0.30)	.029 (0.74)	.004 (0.10)	.085 (2.16)	.296 (7.52)	.030 (0.76)	0.5

Dimensions are in inches (mm). Tolerances: 2Pl. $\pm .01$; 3Pl. $\pm .005$

Notes:

- Case material: Plastic.
- Base: Ceramic.
- Termination finish:
 - For RoHS Case Styles: Tin plate. All models, (+) suffix.
 - For RoHS-5 Case Styles: Tin-Lead plate. All models, no (+) suffix.



INTERNET <http://www.minicircuits.com>

P.O. Box 350166, Brooklyn, New York 11235-0003 (718) 934-4500 Fax (718) 332-4661

Distribution Centers NORTH AMERICA 800-654-7949 • 417-335-5935 • Fax 417-335-5945 • EUROPE 44-1252-832600 • Fax 44-1252-837010

Mini-Circuits ISO 9001 & ISO 14001 Certified

Tape & Reel Packaging TR-F34



Tape Width, mm	Device Cavity Pitch, mm	Reel Size, inches	Devices per Reel see note	
16	12	7	Small quantity standard (see note)	20
				50
				100
				200
		13	Standard	500
				1000

Note: Availability of small reel quantity varies by model.
Refer to pricing and availability on individual model dashboard.

Mini-Circuits carrier tape materials provide protection from ESD (Electro-Static Discharge) during handling and transportation. Tapes are static dissipative and comply with industry standards EIA-481/EIA-541.

Go to: www.minicircuits.com/pages/pdfs/tape.pdf



INTERNET <http://www.minicircuits.com>

P.O. Box 350166, Brooklyn, New York 11235-0003 (718) 934-4500 Fax (718) 332-4661

Distribution Centers NORTH AMERICA 800-654-7949 • 417-335-5935 • Fax 417-335-5945 • EUROPE 44-1252-832600 • Fax 44-1252-837010

Mini-Circuits ISO 9001 & ISO 14001 Certified

THIRD ANGLE PROJECTION

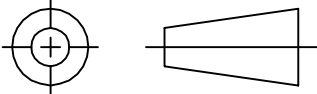

REVISIONS

REV	ECN No.	DESCRIPTION	DATE	DR	AUTH
OR	M87224	NEW RELEASE	05/22/03	MMG	WP
A	M91639	REMOVED NOTE 2, UPDATED DIMENSIONS	04/14/04	AV	DJ
B	M102713	CORRECTED TRACE WIDTH, ADDED "...WITH SMOBC"	01/16/06	GF	IL

SUGGESTED MOUNTING CONFIGURATION FOR DZ943 CASE STYLE, "ny" PIN CONNECTION.

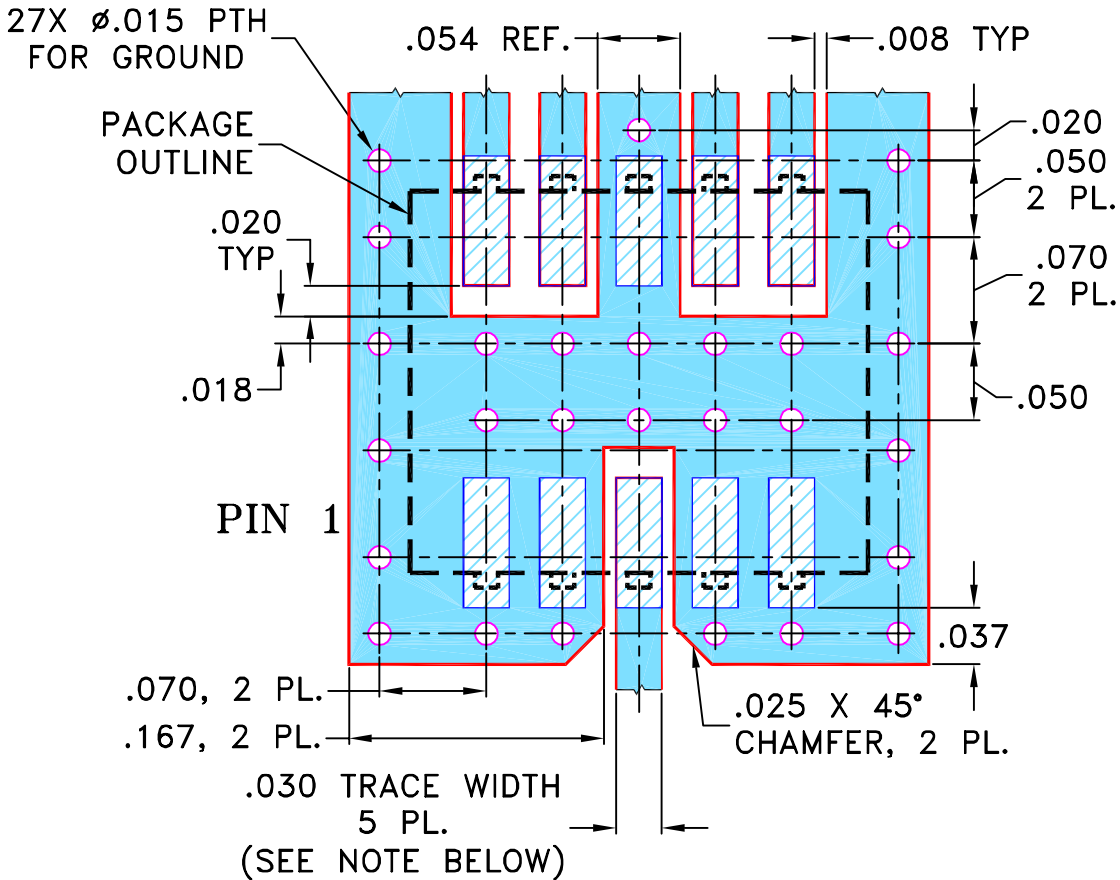

NOTES: 1. TRACE WIDTH IS SHOWN FOR ROGERS R04350B WITH DIELECTRIC THICKNESS 0.030" ± 0.002"; COPPER: 1/2 OZ. EACH SIDE. FOR OTHER MATERIALS TRACE WIDTH MAY NEED TO BE MODIFIED.

2. BOTTOM SIDE OF THE PCB IS CONTINUOUS GROUND PLANE.

- DENOTES PCB COPPER LAYOUT WITH SMOBC (SOLDER MASK OVER BARE COPPER)
- DENOTES COPPER LAND PATTERN FREE OF SOLDER MASK

UNLESS OTHERWISE SPECIFIED	INITIALS		DATE
DIMENSIONS ARE IN INCHES TOLERANCES ON: 2 PL DECIMALS ± 3 PL DECIMALS ± .005 ANGLES ± FRACTIONS ±	DRAWN	MMG	05/21/03
	CHECKED	AV	05/22/03
	APPROVED	WP	05/22/03

Mini-Circuits® 13 Neptune Avenue
Brooklyn NY 11235

PL, ny, 75, DZ943, SCA, TB-247

Mini-Circuits®
THIS DOCUMENT AND ITS CONTENTS ARE THE PROPERTY OF MINI-CIRCUITS. EXCEPT FOR USE EXPRESSLY GRANTED, IN WRITING, TO ITS VENDORS, VENDEE AND THE UNITED STATES GOVERNMENT, MINI-CIRCUITS RESERVES ALL PROPRIETARY DESIGN, USE, MANUFACTURING AND REPRODUCTION RIGHTS THERETO. THESE CONTENTS SHALL NOT BE USED, DUPLICATED OR DISCLOSED TO ANY OUTSIDE PARTY, IN WHOLE OR IN PART, WITHOUT WRITTEN PERMISSION OF MINI-CIRCUITS.

SIZE	CODE IDENT	DRAWING NO:	REV:
A	15542	98-PL-133	B
FILE:	98PL133	SCALE:	8:1
ASHEETA1.DWG REV:A DATE:01/12/95		SHEET:	1 OF 1

Evaluation Board and Circuit

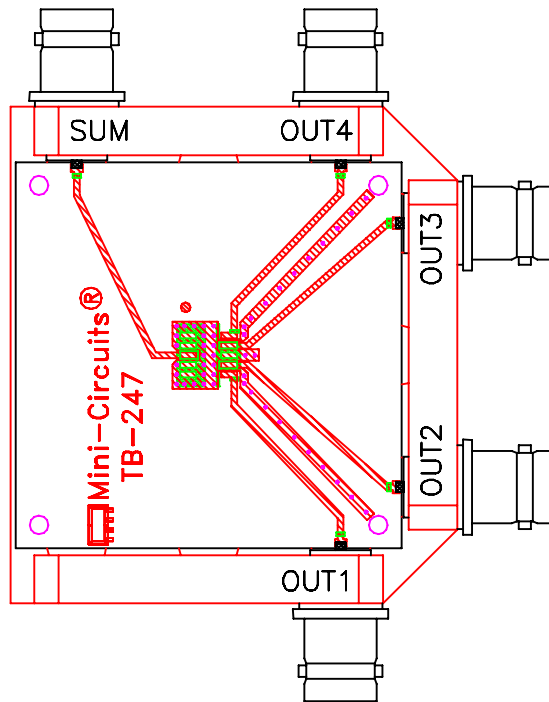

TB-247

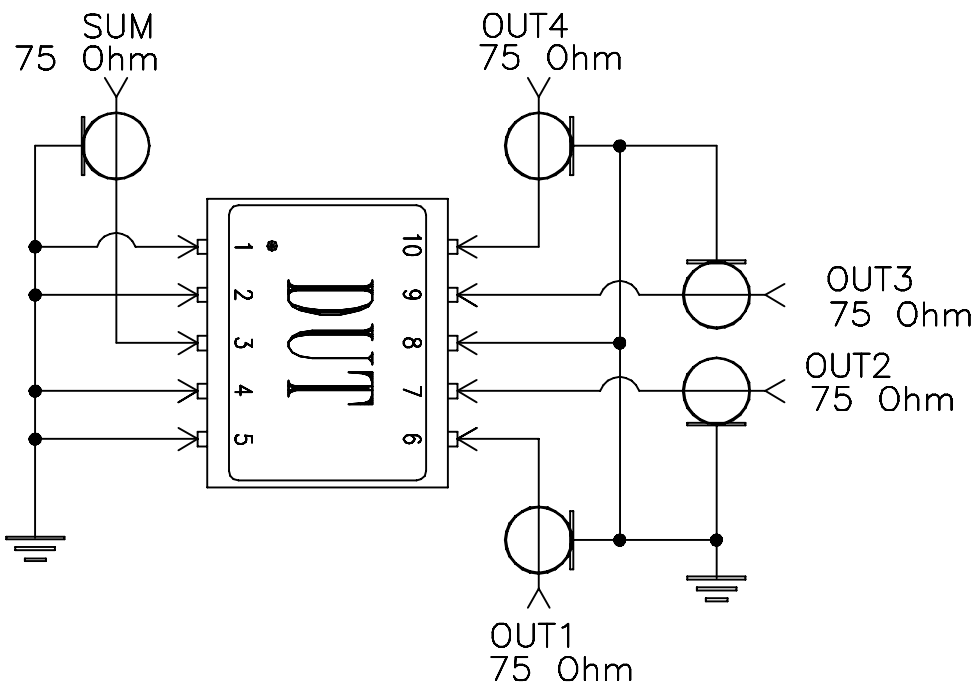

Schematic Diagram

Notes:

1. BNC Female connectors.
2. PCB Material: Rogers R04350 or equivalent,
Dielectric Constant=3.5, Thickness=.030 inch.

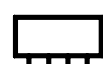
 **Mini-Circuits®**

All Mini-Circuits products are manufactured under exacting quality assurance and control standards, and are capable of meeting published specifications after being subjected to any or all of the following physical and environmental test.

Specification	Test/Inspection Condition	Reference/Spec
Operating Temperature	-40° to 85°C Ambient Environment	Individual Model Data Sheet
Storage Temperature	-55° to 100° C Ambient Environment	Individual Model Data Sheet
Humidity	90 to 95% RH, 240 hours, 50°C	MIL-STD-202, Method 103, Condition A, Except 50°C and end-point electrical test done within 12 hours
Thermal Shock	-55° to 100°C, 100 cycles	MIL-STD-202, Method 107, Condition A-3, except +100°C
Solder Reflow Heat	Sn-Pb Eutetic Process: 225°C peak Pb-Free Process 245° - 250°C peak	J-STD-020, Table 4-1, 4-2 and 5-2, Figure 5-1
Solderability	10X Magnification	J-STD-002, 95% Coverage
Vibration (High Frequency)	20g peak, 10-2000 Hz, 12 times in each of three perpendicular directions (total 36)	MIL-STD-202, Method 204, Condition D
Mechanical Shock	50g, 11 ms, 1/2-sine, 18 shocks: 3 each direction, each of 3 axes	MIL-STD-202, Method 213, Condition A
Marking Resistance to Solvents	Isopropyl alcohol + mineral spirits at 25°C; terpene defluxer at 25°C; distilled water + proylene glycol monomethyl ether + monoethanolamine at 63°C to 70°C	MIL-STD-202, Method 215