

Ultra-Small Ceramic Power Splitter/Combiner

SCN-3-13+ SCN-3-13

3 Way-0° 50Ω 750 to 1325 MHz

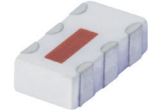

Generic photo used for illustration purposes only
CASE STYLE: FV1206-1

Maximum Ratings

Operating Temperature	-55°C to 100°C
Storage Temperature	-55°C to 100°C
Power Input (as a splitter)	15W* max.

* Derate linearly to 6W at 100°C ambient.
Permanent damage may occur if any of these limits are exceeded.

Pin Connections

SUM PORT	2
PORT 1	6
PORT 2	5
PORT 3	4
GROUND	1,3
PORT 1-2, 2-3	resistor external 124 ohms
PORT 1-3	resistor external 127 ohms

Outline Drawing

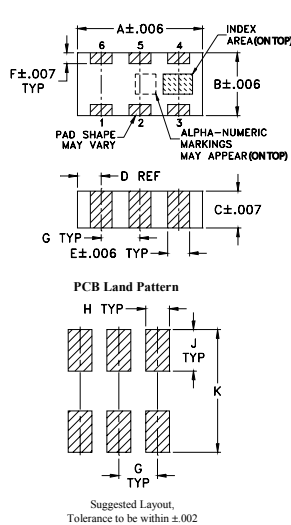

Outline Dimensions (inch/mm)

A	B	C	D	E	F
.126	.063	.035	.024	.022	.011
3.20	1.60	0.89	0.61	0.56	0.28
G	H	J	K	wt	
.039	.024	.042	.123	grams	
0.99	0.61	1.07	3.12	.020	

Demo Board MCL P/N: TB-303 Suggested PCB Layout (PL-171)

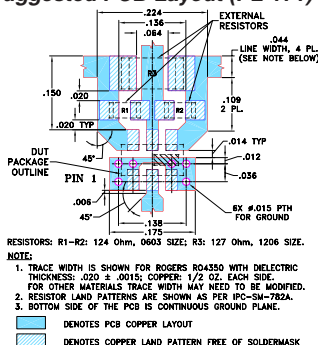

Notes

- Performance and quality attributes and conditions not expressly stated in this specification document are intended to be excluded and do not form a part of this specification document.
- Electrical specifications and performance data contained in this specification document are based on Mini-Circuit's applicable established test performance criteria and measurement instructions.
- The parts covered by this specification document are subject to Mini-Circuit's standard limited warranty and terms and conditions (collectively, "Standard Terms"); Purchasers of this part are entitled to the rights and benefits contained therein. For a full statement of the Standard Terms and the exclusive rights and remedies thereunder, please visit Mini-Circuit's website at www.minicircuits.com/WCLStore/terms.jsp

Features

- isolation resistors, external
- low insertion loss, 1.0 dB typ.
- excellent amplitude unbalance, 0.3 dB typ.
- very good phase unbalance, 1 deg. typ.
- high isolation, 12 dB typ.
- excellent power handling, 15W as splitter
- small size, 0.12"X0.06"X0.035"
- ESD non-sensitive
- temperature stable LTCC technology
- wrap around, terminations for excellent solderability
- low cost

Applications

- DSS
- WLAN
- satellite communication
- GSM, GPS
- ISM applications
- defense applications

Electrical Specifications

FREQ. RANGE (MHz)	ISOLATION (dB)		INSERTION LOSS (dB) ABOVE 4.8 dB		PHASE UNBALANCE (Degrees)		AMPLITUDE UNBALANCE (dB)		RETURN LOSS (dB)	
	Typ.	Min.	Typ.	Max.	Typ.	Max.	Typ.	Max.	INPUT Typ.	OUTPUT Typ.
f_L - f_U										
750-1325	12	10	1.0	1.5	1.0	3.0	0.3	0.7	12	20
850-1000	16	12	0.4	0.8	0.5	3.0	0.2	0.5	15	20

Typical Performance Data

Freq. (MHz)	Total Loss ¹ (dB)			Amp. Unbal. (dB)	Isolation (dB)			Phase Unbal. (deg.)	Return Loss (dB)		
	S-1	S-2	S-3		1-2	1-3	2-3		S	1	2
750.00	5.34	5.51	5.44	0.17	14.30	12.76	14.40	0.91	10.53	20.85	19.89
800.00	5.26	5.44	5.36	0.17	15.41	13.51	15.51	1.02	11.47	21.53	21.25
850.00	5.19	5.38	5.29	0.19	16.74	14.37	16.81	1.07	12.65	21.58	22.33
900.00	5.12	5.32	5.23	0.20	18.39	15.41	18.41	1.20	14.17	21.18	22.67
950.00	5.06	5.27	5.18	0.22	20.49	16.67	20.45	1.30	16.24	20.59	22.75
1000.00	5.02	5.25	5.14	0.23	23.24	18.24	23.00	1.39	19.19	19.97	22.41
1050.00	4.99	5.24	5.12	0.25	26.57	20.24	25.81	1.45	23.51	19.48	22.03
1100.00	4.99	5.26	5.13	0.27	27.86	22.80	26.64	1.54	26.97	19.24	22.00
1150.00	5.03	5.32	5.18	0.29	24.65	25.48	23.98	1.61	21.70	19.28	22.07
1200.00	5.11	5.42	5.27	0.32	21.07	25.93	20.77	1.64	16.90	19.74	22.80
1250.00	5.24	5.59	5.41	0.35	18.22	23.16	18.08	1.73	13.45	20.72	24.18
1300.00	5.44	5.83	5.62	0.39	16.00	20.05	15.93	1.79	10.86	22.51	27.00
1325.00	5.57	5.98	5.76	0.41	15.07	18.71	15.03	1.81	9.77	23.94	29.65

1. Total Loss = Insertion Loss + 4.8dB splitter loss.

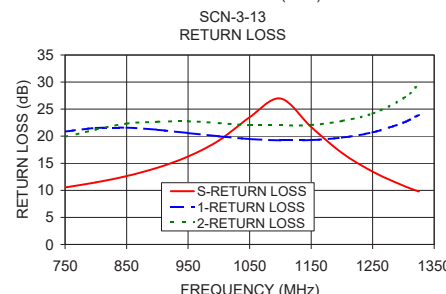
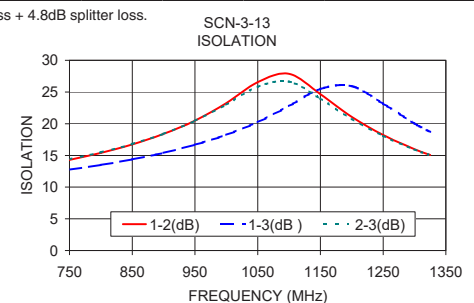
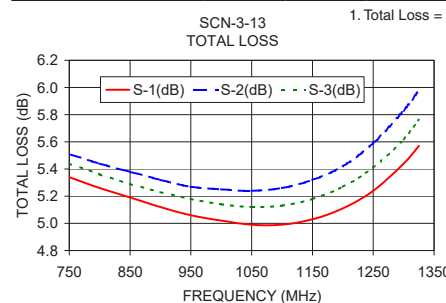

electrical schematic

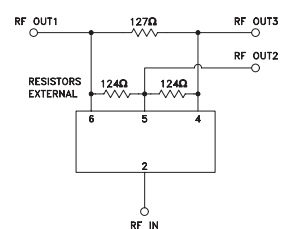

www.minicircuits.com P.O. Box 350166, Brooklyn, NY 11235-0003 (718) 934-4500 sales@minicircuits.com

REV. E
M151107
ED-11736/2
SCN-3-13
AD/DJ/CP/AM
150928
Page 1 of 1

3 Way-0° Power Splitter/Combiner

SCN-3-13

Typical Performance Data

TEST CONDITIONS: INPUT POWER = 0dBm @Temperature = +25°C

FREQ. (MHz)	TOTAL LOSS ¹ (dB)			AMP. UNBAL. (dB)	PHASE UNBAL. (deg.)	ISOLATION (dB)			VSWR (:1)			
	S-1	S-2	S-3			1-2	1-3	2-3	S	1	2	3
10	6.03	6.01	6.07	0.06	0.24	6.09	6.15	6.10	2.96	2.91	2.94	2.93
50	6.00	6.00	6.07	0.07	0.52	6.16	6.25	6.20	2.93	2.83	2.86	2.86
100	6.04	6.01	6.08	0.07	0.43	6.38	6.48	6.41	2.91	2.68	2.73	2.69
150	6.06	6.03	6.08	0.05	0.33	6.68	6.80	6.71	2.89	2.50	2.56	2.50
200	6.06	6.02	6.08	0.06	0.31	7.03	7.18	7.07	2.86	2.31	2.38	2.31
250	6.06	6.02	6.06	0.04	0.32	7.46	7.60	7.50	2.83	2.12	2.20	2.12
300	6.02	6.00	6.03	0.03	0.40	7.92	8.04	7.96	2.78	1.94	2.03	1.94
350	5.99	5.98	6.01	0.03	0.48	8.43	8.52	8.46	2.73	1.79	1.87	1.78
400	5.95	5.95	5.98	0.03	0.55	8.98	8.99	9.00	2.67	1.65	1.73	1.65
450	5.89	5.90	5.94	0.05	0.60	9.56	9.49	9.57	2.60	1.53	1.60	1.53
500	5.84	5.86	5.88	0.04	0.70	10.19	10.00	10.19	2.52	1.42	1.49	1.43
550	5.78	5.81	5.83	0.05	0.77	10.85	10.52	10.84	2.43	1.34	1.40	1.34
600	5.73	5.76	5.78	0.05	0.87	11.59	11.09	11.55	2.34	1.26	1.32	1.27
650	5.65	5.70	5.71	0.06	0.98	12.38	11.70	12.31	2.24	1.21	1.25	1.21
700	5.57	5.62	5.64	0.07	1.00	13.26	12.36	13.17	2.13	1.16	1.19	1.17
725	5.53	5.59	5.60	0.07	1.02	13.74	12.72	13.63	2.08	1.15	1.17	1.15
750	5.49	5.55	5.57	0.08	1.09	14.26	13.10	14.13	2.02	1.14	1.15	1.14
775	5.45	5.53	5.53	0.08	1.14	14.83	13.51	14.66	1.96	1.13	1.14	1.13
800	5.41	5.48	5.49	0.08	1.15	15.42	13.93	15.24	1.90	1.13	1.12	1.12
825	5.36	5.45	5.46	0.10	1.20	16.09	14.41	15.87	1.83	1.13	1.12	1.12
850	5.32	5.41	5.42	0.10	1.22	16.82	14.93	16.56	1.77	1.14	1.11	1.12
875	5.28	5.37	5.38	0.10	1.26	17.63	15.48	17.32	1.70	1.14	1.11	1.12
900	5.24	5.34	5.34	0.10	1.31	18.53	16.10	18.17	1.63	1.15	1.11	1.13
925	5.20	5.31	5.31	0.11	1.28	19.57	16.77	19.12	1.56	1.15	1.11	1.13
950	5.16	5.28	5.28	0.12	1.34	20.76	17.52	20.19	1.49	1.16	1.11	1.13
975	5.11	5.25	5.24	0.14	1.35	22.14	18.37	21.40	1.42	1.16	1.11	1.13
1000	5.08	5.23	5.22	0.15	1.36	23.75	19.32	22.76	1.35	1.16	1.11	1.13
1025	5.05	5.21	5.20	0.16	1.39	25.58	20.40	24.25	1.27	1.16	1.11	1.13
1050	5.03	5.20	5.18	0.17	1.41	27.47	21.58	25.68	1.20	1.16	1.11	1.13
1075	5.01	5.20	5.17	0.19	1.46	28.81	22.91	26.72	1.13	1.16	1.10	1.12
1100	5.00	5.20	5.18	0.20	1.47	28.53	24.29	26.73	1.06	1.15	1.10	1.11
1125	5.01	5.23	5.19	0.22	1.47	26.76	25.43	25.66	1.01	1.14	1.09	1.10
1150	5.02	5.26	5.21	0.24	1.46	24.60	25.92	24.04	1.09	1.12	1.08	1.09
1175	5.05	5.30	5.25	0.25	1.47	22.62	25.49	22.33	1.18	1.11	1.07	1.07
1200	5.09	5.36	5.30	0.27	1.51	20.86	24.26	20.75	1.28	1.09	1.05	1.06
1225	5.16	5.45	5.38	0.30	1.49	19.36	22.73	19.32	1.40	1.07	1.05	1.04
1250	5.24	5.56	5.48	0.32	1.54	18.04	21.18	18.06	1.53	1.06	1.05	1.05
1275	5.34	5.70	5.60	0.35	1.54	16.91	19.77	16.95	1.69	1.05	1.07	1.06
1300	5.48	5.86	5.76	0.38	1.53	15.91	18.49	15.97	1.86	1.06	1.10	1.09
1325	5.63	6.04	5.93	0.41	1.51	15.04	17.38	15.11	2.07	1.09	1.14	1.13
1350	5.82	6.27	6.14	0.45	1.51	14.26	16.39	14.34	2.30	1.13	1.18	1.17
1375	6.05	6.53	6.38	0.48	1.51	13.60	15.55	13.68	2.57	1.17	1.23	1.22
1400	6.31	6.82	6.65	0.52	1.51	13.02	14.79	13.10	2.89	1.22	1.28	1.27
1450	6.91	7.52	7.30	0.60	1.44	12.08	13.58	12.16	3.67	1.34	1.40	1.39
1500	7.65	8.35	8.08	0.70	1.40	11.40	12.68	11.49	4.70	1.47	1.54	1.53
1550	8.50	9.32	8.99	0.82	1.37	10.95	12.04	11.03	6.07	1.62	1.70	1.68
1600	9.46	10.43	10.01	0.97	1.52	10.68	11.60	10.75	7.87	1.78	1.87	1.85

¹ Total Loss = Insertion Loss+ 4.8dB Splitter Loss

3 Way-0° Power Splitter/Combiner

SCN-3-13

Typical Performance Data

TEST CONDITIONS: INPUT POWER = 0dBm @Temperature = -55°C

FREQ. (MHz)	TOTAL LOSS ¹ (dB)			AMP. UNBAL. (dB)	PHASE UNBAL. (deg.)	ISOLATION (dB)			VSWR (:1)			
	S-1	S-2	S-3			1-2	1-3	2-3	S	1	2	3
10	6.01	6.01	6.06	0.05	0.26	6.07	6.12	6.08	2.98	2.94	2.96	2.96
50	5.98	5.98	6.04	0.06	0.53	6.12	6.20	6.16	2.95	2.86	2.88	2.88
100	5.99	5.98	6.02	0.04	0.53	6.36	6.44	6.39	2.91	2.72	2.77	2.73
150	6.05	6.00	6.03	0.05	0.13	6.61	6.73	6.62	2.94	2.54	2.58	2.52
200	5.98	5.98	6.01	0.03	0.10	6.98	7.12	7.05	2.87	2.33	2.43	2.35
250	5.99	5.94	5.98	0.05	0.31	7.40	7.54	7.43	2.85	2.16	2.23	2.15
300	5.96	5.94	5.97	0.03	0.26	7.84	7.96	7.88	2.82	1.96	2.05	1.96
350	5.88	5.89	5.93	0.05	0.37	8.35	8.44	8.41	2.74	1.80	1.90	1.83
400	5.87	5.87	5.89	0.02	0.28	8.88	8.89	8.90	2.70	1.67	1.74	1.67
450	5.80	5.82	5.83	0.03	0.46	9.48	9.38	9.48	2.62	1.54	1.63	1.54
500	5.74	5.76	5.78	0.04	0.53	10.08	9.89	10.08	2.54	1.44	1.51	1.45
550	5.68	5.71	5.71	0.03	0.56	10.74	10.40	10.71	2.46	1.36	1.41	1.35
600	5.61	5.65	5.66	0.05	0.70	11.49	10.98	11.44	2.36	1.28	1.33	1.28
650	5.53	5.58	5.59	0.06	0.76	12.29	11.60	12.23	2.26	1.22	1.26	1.23
700	5.45	5.50	5.51	0.06	0.77	13.19	12.28	13.09	2.16	1.18	1.20	1.18
725	5.41	5.47	5.48	0.07	0.77	13.69	12.66	13.60	2.10	1.16	1.17	1.16
750	5.36	5.42	5.44	0.08	0.80	14.24	13.06	14.11	2.04	1.15	1.16	1.15
775	5.31	5.40	5.40	0.09	0.80	14.83	13.48	14.68	1.97	1.14	1.14	1.15
800	5.27	5.35	5.35	0.08	0.83	15.46	13.92	15.26	1.91	1.14	1.13	1.14
825	5.22	5.31	5.31	0.09	0.86	16.15	14.42	15.92	1.85	1.15	1.12	1.13
850	5.18	5.27	5.28	0.10	0.90	16.92	14.96	16.67	1.78	1.15	1.12	1.13
875	5.12	5.23	5.22	0.11	0.91	17.82	15.57	17.53	1.70	1.16	1.12	1.14
900	5.07	5.19	5.18	0.12	0.92	18.84	16.24	18.46	1.63	1.16	1.12	1.14
925	5.03	5.16	5.15	0.13	0.95	19.95	16.96	19.48	1.56	1.16	1.12	1.14
950	4.99	5.12	5.11	0.13	0.97	21.25	17.76	20.65	1.48	1.16	1.12	1.14
975	4.95	5.09	5.07	0.14	0.98	22.81	18.68	22.01	1.41	1.17	1.12	1.14
1000	4.91	5.07	5.05	0.16	1.00	24.74	19.76	23.63	1.33	1.17	1.13	1.14
1025	4.87	5.05	5.03	0.18	1.01	27.00	21.00	25.39	1.25	1.17	1.12	1.14
1050	4.85	5.04	5.01	0.19	1.02	29.18	22.35	26.94	1.18	1.16	1.12	1.13
1075	4.83	5.04	5.00	0.21	1.06	30.15	23.85	27.76	1.11	1.16	1.11	1.12
1100	4.83	5.04	5.00	0.21	1.06	28.80	25.43	27.18	1.04	1.16	1.10	1.11
1125	4.83	5.07	5.02	0.24	1.05	26.27	26.67	25.49	1.05	1.15	1.09	1.10
1150	4.85	5.10	5.04	0.25	1.03	23.82	26.77	23.49	1.13	1.13	1.08	1.09
1175	4.88	5.16	5.09	0.28	1.04	21.74	25.62	21.62	1.23	1.11	1.06	1.07
1200	4.92	5.22	5.15	0.30	1.06	20.01	23.89	19.98	1.34	1.09	1.04	1.05
1225	5.00	5.32	5.23	0.32	1.06	18.55	22.13	18.57	1.46	1.07	1.04	1.03
1250	5.09	5.43	5.34	0.34	1.12	17.26	20.48	17.32	1.61	1.05	1.05	1.04
1275	5.20	5.58	5.47	0.38	1.18	16.15	19.01	16.22	1.78	1.04	1.07	1.06
1300	5.36	5.76	5.65	0.40	1.20	15.17	17.71	15.25	1.99	1.06	1.11	1.10
1325	5.53	5.97	5.83	0.44	1.27	14.33	16.63	14.41	2.22	1.10	1.15	1.14
1350	5.74	6.21	6.06	0.47	1.34	13.59	15.66	13.68	2.50	1.14	1.20	1.19
1375	5.99	6.50	6.33	0.51	1.39	12.96	14.84	13.05	2.81	1.19	1.25	1.25
1400	6.27	6.82	6.63	0.56	1.46	12.42	14.12	12.51	3.19	1.25	1.32	1.31
1450	6.94	7.59	7.34	0.65	1.62	11.55	12.98	11.63	4.13	1.38	1.45	1.44
1500	7.73	8.51	8.20	0.78	1.75	10.95	12.15	11.04	5.44	1.53	1.61	1.60
1550	8.65	9.57	9.18	0.92	1.95	10.56	11.58	10.64	7.21	1.69	1.79	1.77
1600	9.69	10.76	10.28	1.07	2.16	10.35	11.21	10.42	9.69	1.87	1.99	1.95

¹ Total Loss = Insertion Loss+ 4.8dB Splitter Loss

3 Way-0° Power Splitter/Combiner

SCN-3-13

Typical Performance Data

TEST CONDITIONS: INPUT POWER = 0dBm @Temperature = +100°C

FREQ. (MHz)	TOTAL LOSS ¹ (dB)			AMP. UNBAL. (dB)	PHASE UNBAL. (deg.)	ISOLATION (dB)			VSWR (:1)			
	S-1	S-2	S-3			1-2	1-3	2-3	S	1	2	3
10	6.04	6.02	6.08	0.06	0.24	6.12	6.18	6.13	2.95	2.88	2.92	2.91
50	6.02	6.01	6.08	0.07	0.63	6.19	6.27	6.22	2.92	2.81	2.85	2.85
100	6.09	6.04	6.11	0.07	0.45	6.39	6.49	6.40	2.93	2.66	2.69	2.66
150	6.07	6.06	6.10	0.04	0.37	6.72	6.84	6.77	2.86	2.47	2.56	2.50
200	6.11	6.06	6.11	0.05	0.47	7.05	7.18	7.06	2.87	2.29	2.36	2.28
250	6.10	6.06	6.11	0.05	0.30	7.48	7.61	7.52	2.84	2.09	2.17	2.09
300	6.04	6.02	6.07	0.05	0.62	7.94	8.07	7.99	2.76	1.92	2.01	1.94
350	6.06	6.02	6.07	0.05	0.48	8.44	8.53	8.45	2.75	1.77	1.83	1.76
400	5.99	6.00	6.04	0.05	0.46	9.01	9.01	9.04	2.67	1.62	1.71	1.63
450	5.94	5.96	5.99	0.05	0.76	9.59	9.52	9.61	2.60	1.51	1.59	1.52
500	5.91	5.93	5.96	0.05	0.76	10.22	10.02	10.21	2.54	1.40	1.47	1.41
550	5.84	5.87	5.90	0.06	0.86	10.90	10.57	10.89	2.44	1.31	1.38	1.33
600	5.79	5.82	5.85	0.06	0.97	11.65	11.15	11.60	2.35	1.25	1.30	1.25
650	5.72	5.76	5.79	0.07	0.99	12.44	11.76	12.38	2.25	1.19	1.23	1.20
700	5.63	5.69	5.71	0.08	1.06	13.34	12.44	13.25	2.13	1.15	1.18	1.16
725	5.60	5.66	5.68	0.08	1.14	13.82	12.80	13.71	2.08	1.13	1.16	1.14
750	5.57	5.62	5.64	0.07	1.17	14.34	13.18	14.20	2.02	1.12	1.14	1.12
775	5.53	5.59	5.61	0.08	1.15	14.90	13.59	14.74	1.96	1.12	1.12	1.11
800	5.48	5.55	5.57	0.09	1.17	15.50	14.01	15.31	1.90	1.11	1.11	1.11
825	5.44	5.52	5.53	0.09	1.21	16.17	14.49	15.94	1.83	1.11	1.10	1.11
850	5.40	5.48	5.50	0.10	1.23	16.89	14.99	16.62	1.76	1.11	1.09	1.11
875	5.35	5.44	5.46	0.10	1.25	17.68	15.53	17.35	1.70	1.12	1.08	1.11
900	5.31	5.41	5.42	0.11	1.28	18.55	16.13	18.17	1.63	1.12	1.08	1.11
925	5.28	5.38	5.39	0.11	1.27	19.54	16.78	19.08	1.56	1.13	1.08	1.11
950	5.24	5.35	5.36	0.12	1.27	20.68	17.50	20.09	1.49	1.13	1.09	1.11
975	5.20	5.33	5.33	0.13	1.33	21.99	18.32	21.24	1.41	1.14	1.09	1.11
1000	5.17	5.30	5.30	0.13	1.29	23.45	19.21	22.47	1.34	1.14	1.09	1.11
1025	5.14	5.29	5.28	0.15	1.31	25.08	20.21	23.83	1.27	1.14	1.09	1.11
1050	5.12	5.28	5.27	0.16	1.31	26.67	21.29	25.05	1.20	1.13	1.08	1.10
1075	5.10	5.28	5.27	0.18	1.31	27.79	22.47	25.92	1.13	1.13	1.08	1.10
1100	5.10	5.29	5.27	0.19	1.31	27.69	23.63	26.01	1.06	1.12	1.07	1.09
1125	5.11	5.32	5.28	0.21	1.34	26.36	24.61	25.24	1.04	1.11	1.07	1.08
1150	5.12	5.35	5.31	0.23	1.30	24.55	25.06	23.89	1.11	1.10	1.06	1.07
1175	5.15	5.40	5.35	0.25	1.33	22.81	24.85	22.41	1.19	1.09	1.05	1.06
1200	5.19	5.46	5.40	0.26	1.31	21.14	23.97	20.96	1.29	1.07	1.05	1.05
1225	5.26	5.55	5.49	0.29	1.29	19.70	22.72	19.62	1.40	1.06	1.05	1.05
1250	5.35	5.66	5.58	0.31	1.27	18.42	21.36	18.40	1.53	1.06	1.07	1.06
1275	5.44	5.78	5.70	0.34	1.23	17.31	20.06	17.32	1.67	1.06	1.09	1.08
1300	5.58	5.95	5.85	0.37	1.21	16.33	18.86	16.36	1.84	1.08	1.12	1.11
1325	5.73	6.12	6.01	0.40	1.17	15.47	17.81	15.52	2.03	1.11	1.15	1.15
1350	5.91	6.33	6.21	0.42	1.16	14.70	16.86	14.77	2.25	1.14	1.19	1.18
1375	6.12	6.58	6.44	0.47	1.11	14.03	16.01	14.11	2.50	1.18	1.23	1.23
1400	6.36	6.85	6.69	0.50	1.08	13.45	15.26	13.52	2.79	1.23	1.28	1.28
1450	6.93	7.51	7.30	0.57	0.96	12.48	14.03	12.55	3.49	1.33	1.39	1.38
1500	7.61	8.28	8.03	0.67	0.86	11.77	13.10	11.84	4.39	1.45	1.51	1.50
1550	8.40	9.18	8.86	0.78	0.71	11.26	12.41	11.34	5.55	1.58	1.65	1.64
1600	9.30	10.20	9.81	0.90	0.53	10.93	11.93	11.01	7.02	1.73	1.80	1.79

¹ Total Loss = Insertion Loss+ 4.8dB Splitter Loss

3 Way-0° Power Splitter/Combiner

SCN-3-13

Typical Performance Curves

Total Loss

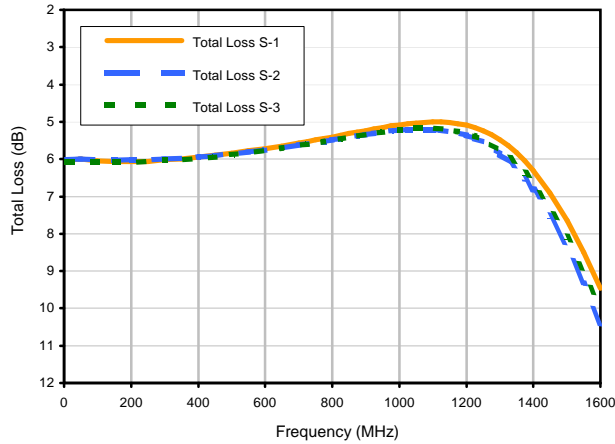

Total Loss S-1 vs. TEMPERATURE

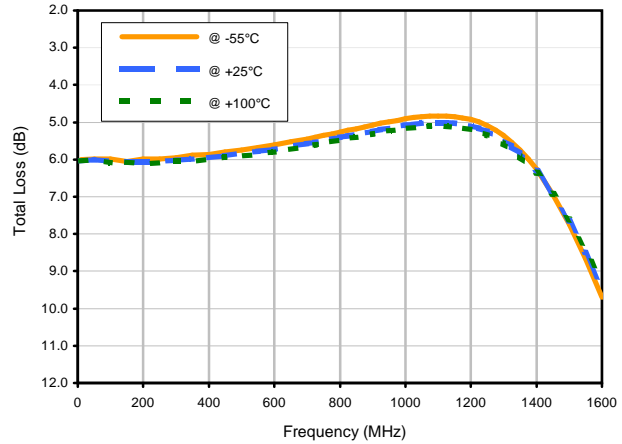

Amplitude Unbalance vs. TEMPERATURE

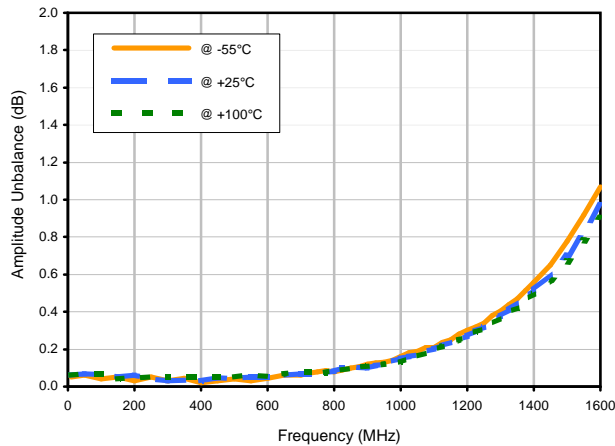

Phase Unbalance vs. TEMPERATURE

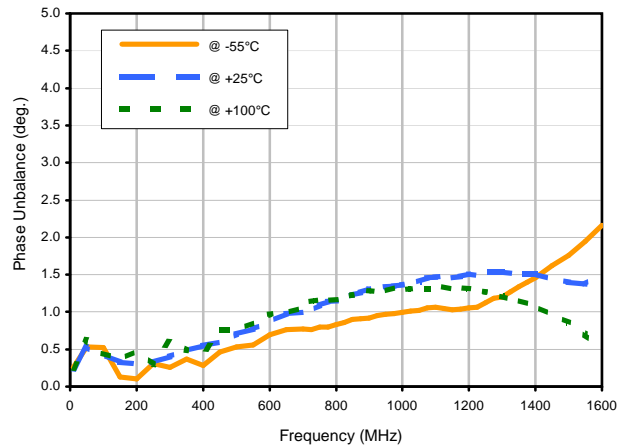

Isolation

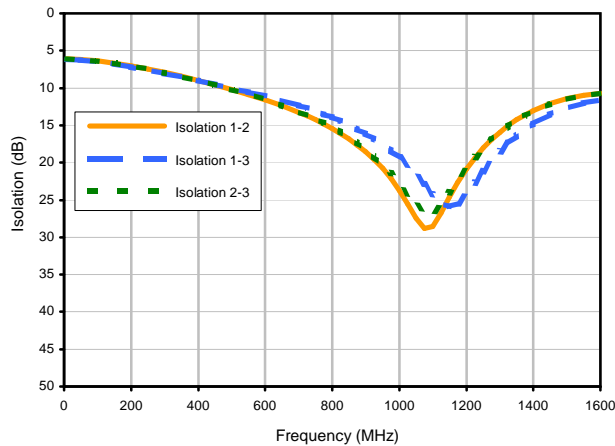

Isolation 1-2 vs. TEMPERATURE

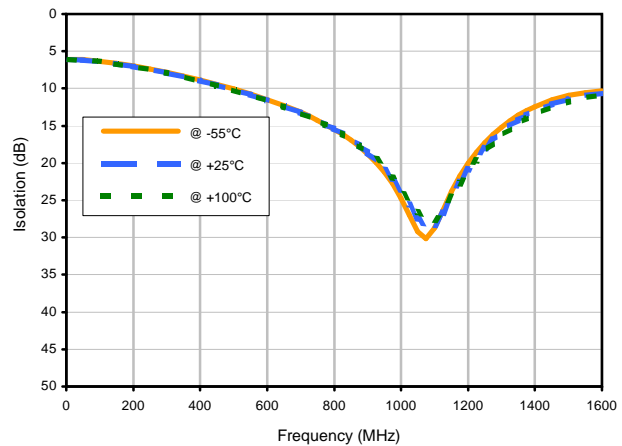

REV. X2
SCN-3-13
100627
Page 1 of 2



RF/MICROWAVE COMPONENTS • ISO 9001 ISO 14001 AS 9100 CERTIFIED • RoHS compliant
P.O. Box 350166, Brooklyn, New York 11235-0006 (718) 934-4500 Fax (718) 332-4661



The Design Engineers Search Engine finds the model you need, Instantly • For detailed performance specs & shopping online see



Typical Performance Curves

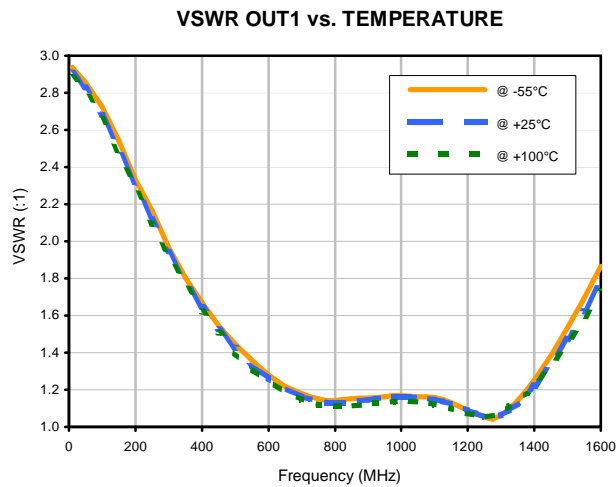
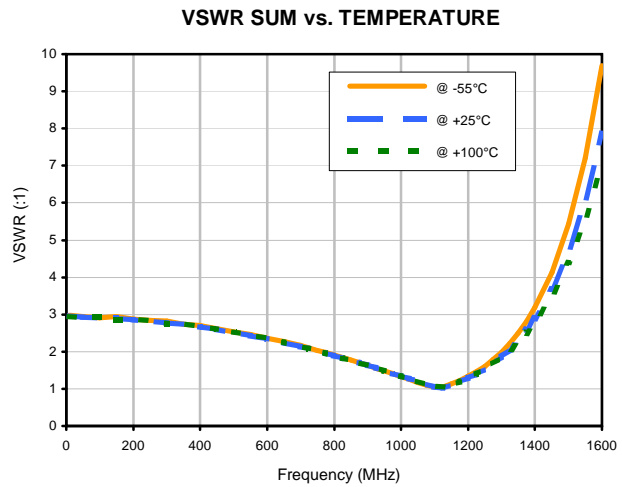
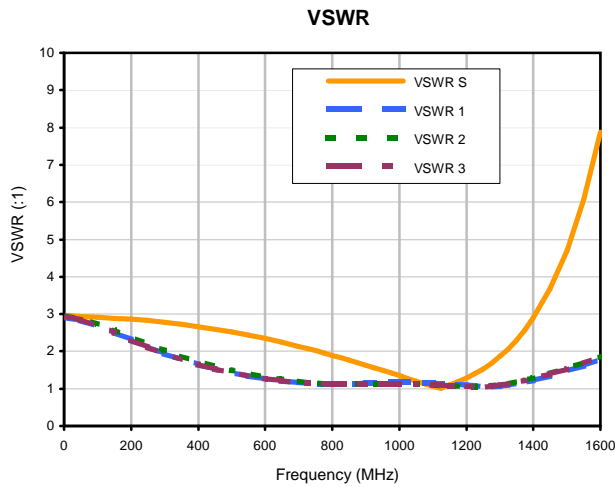

Outline Dimensions

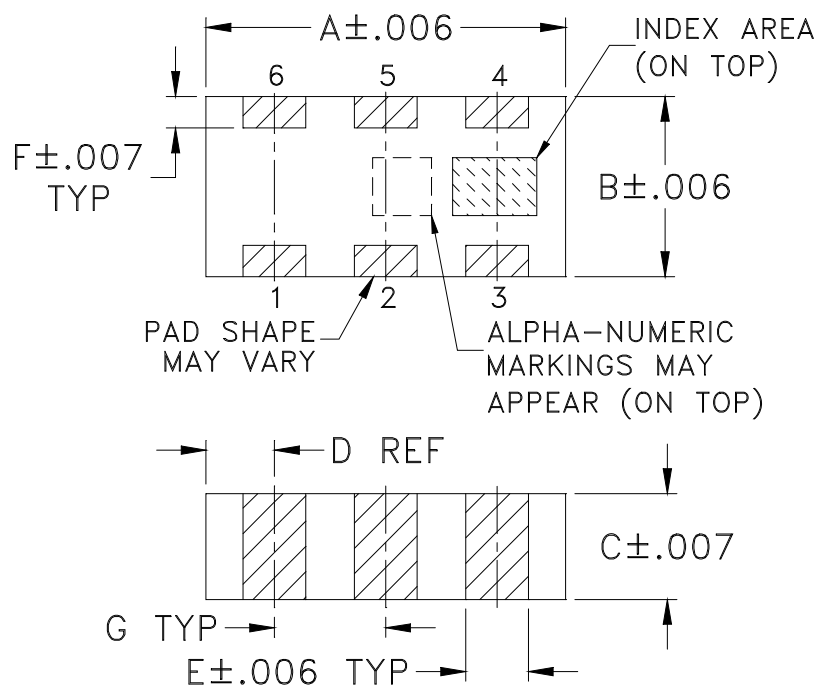

PCB Land Pattern

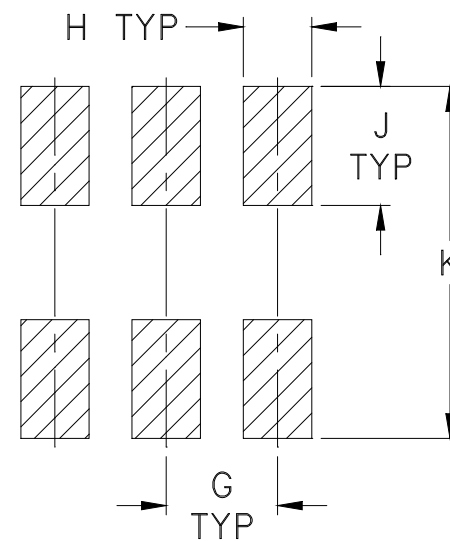

Suggested Layout,
Tolerance to be within $\pm.002$

CASE #	A	B	C	D	E	F	G	H	J	K	L	M	N	P	WT. GRAM
FV1206-1	.126 (3.20)	.063 (1.60)	.035 (0.89)	.024 (0.61)	.022 (0.56)	.011 (0.28)	.039 (0.99)	.024 (0.61)	.042 (1.07)	.123 (3.12)	--	--	--	--	.020

Dimensions are in inches (mm). Tolerances: 2 Pl. $\pm.01$; 3 Pl. $\pm.005$

Notes:

- Open style, ceramic base.
- Termination finish: **as shown below or indicated on Data Sheet.**
For RoHS Case Styles: Tin plate over Nickel plate. All models, (+) suffix.
For RoHS-5 Case Styles: Tin-Lead plate. All models, no (+) suffix.



P.O. Box 350166, Brooklyn, New York 11235-0003 (718) 934-4500 Fax (718) 332-4661 For detailed performance specs & shopping online see Mini-Circuits web site



The Design Engineers Search Engine Provides ACTUAL Data Instantly From MINI-CIRCUITS At: www.minicircuits.com

RF/IF MICROWAVE COMPONENTS

DEVICE ORIENTATION IN T&R

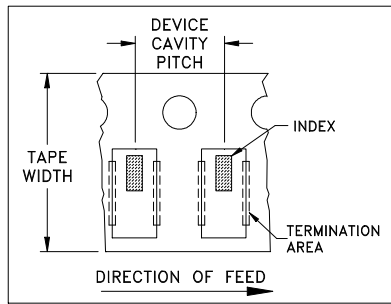

ILLUSTRATION 1

Applicable Case Styles
FV1206-1
FV1206-3

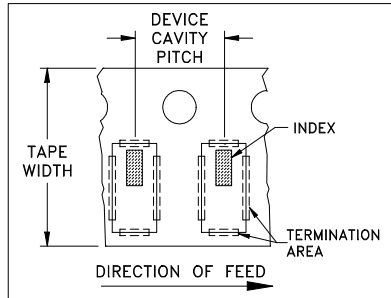

ILLUSTRATION 2

Applicable Case Styles
FV1206-4
FV1206-5
FV1206-6
FV1206-7
FV1206-9

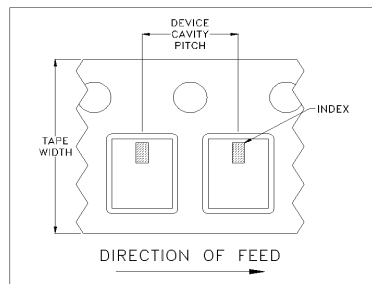

ILLUSTRATION 3

Applicable Case Styles
FV1206-11
FV1206-12
GE0805C-18
NL1008C-6
NL1008C-7
NL1008C-9
NL1008C-10
NL1008C-12

Tape Width, mm	Device Cavity Pitch, mm	Reel Size, inches	Devices per Reel	
8	4	7	Small quantity standards (see note)	20
				50
				100
				200
				500
				1000
			Standard	3000

Note: Please consult individual model data sheet to determine device per reel availability.

Mini-Circuits carrier tape materials provide protection from ESD (Electro-Static Discharge) during handling and transportation. Tapes are static dissipative and comply with industry standards EIA-481/EIA-541.

Go to: www.minicircuits.com/pages/pdfs/tape.pdf



Distribution Centers NORTH AMERICA 800-654-7949 • 417-335-5935 • Fax 417-335-5945 • EUROPE 44-1252-832600 • Fax 44-1252-837010
 Mini-Circuits ISO 9001 & ISO 14001 Certified

INTERNET <http://www.minicircuits.com>

P.O. Box 350166, Brooklyn, New York 11235-0003 (718) 934-4500 Fax (718) 332-4661

THIRD ANGLE PROJECTION

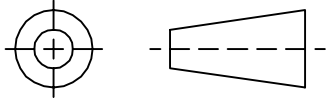

REVISIONS

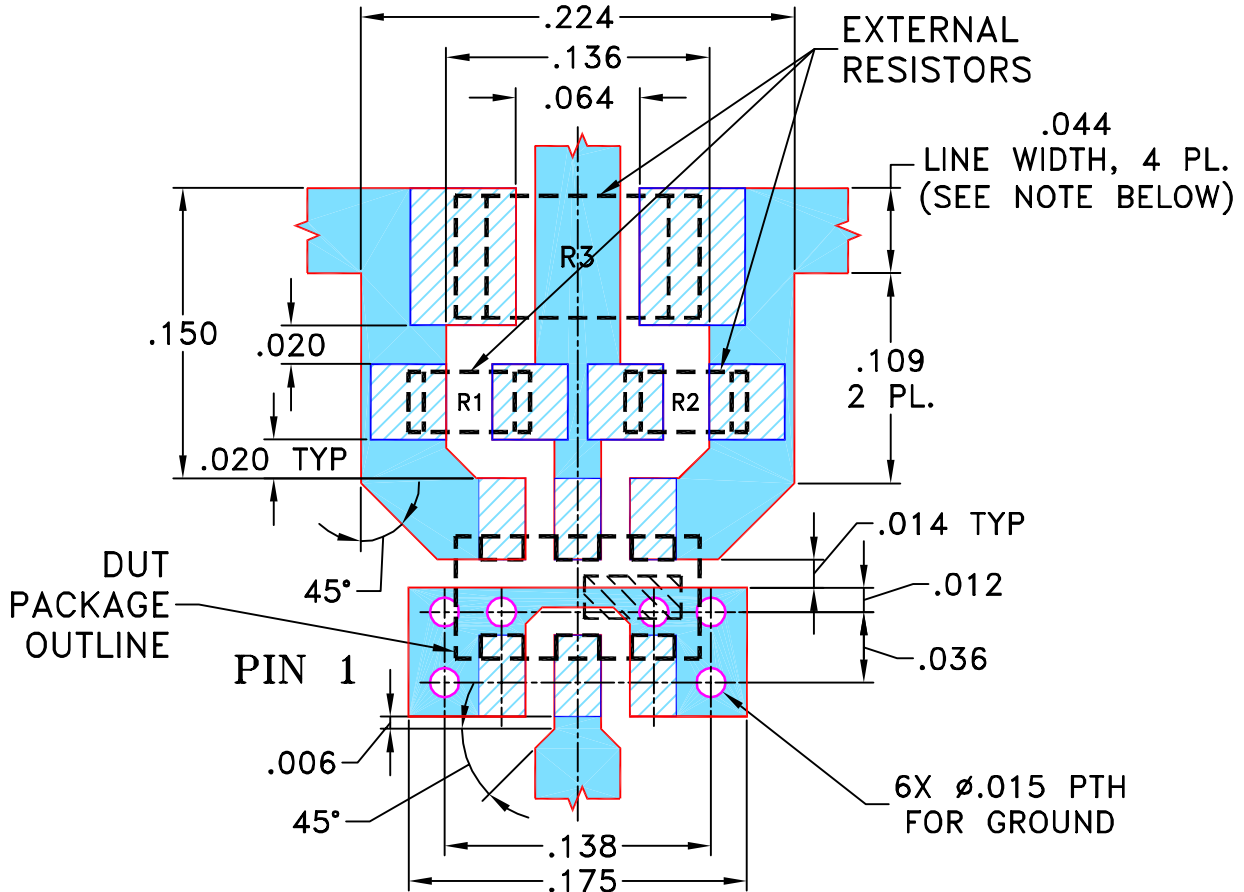

REV	ECN No.	DESCRIPTION	DATE	DR	AUTH
OR	M94644	NEW RELEASE	10/12/04	MMG	ABD
A	M102713	ADDED "...WITH SMOBC", REMOVED NOTE 2	01/20/06	GT	IL

SUGGESTED MOUNTING CONFIGURATION
FOR FV1206-1 CASE STYLE, "qc" PIN CONNECTION.



RESISTORS: R1-R2: 124 Ohm, 0603 SIZE; R3: 127 Ohm, 1206 SIZE.

- NOTES:** 1. TRACE WIDTH IS SHOWN FOR ROGERS R04350B WITH DIELECTRIC THICKNESS: .020" ± .0015"; COPPER: 1/2 OZ. EACH SIDE. FOR OTHER MATERIALS TRACE WIDTH MAY NEED TO BE MODIFIED.
 2. BOTTOM SIDE OF THE PCB IS CONTINUOUS GROUND PLANE.

 DENOTES PCB COPPER LAYOUT WITH SMOBC (SOLDER MASK OVER BARE COPPER)
 DENOTES COPPER LAND PATTERN FREE OF SOLDER MASK

UNLESS OTHERWISE SPECIFIED	INITIALS	DATE
DIMENSIONS ARE IN INCHES	DRAWN MMG	10/04/04
TOLERANCES ON:	CHECKED AV	10/12/04
2 PL DECIMALS ±	APPROVED ABD	10/12/04
3 PL DECIMALS ± .005		
ANGLES ±		
FRACTIONS ±		

 **Mini-Circuits®** 13 Neptune Avenue
 Brooklyn NY 11235

PL, qc, FV1206-1, SCN-3, TB-303

SIZE A	CODE IDENT 15542	DRAWING NO: 98-PL-171	REV: A
FILE: 98PL171	SCALE: 10:1	SHEET: 1 OF 1	

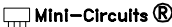
 Mini-Circuits®
 THIS DOCUMENT AND ITS CONTENTS ARE THE PROPERTY OF MINI-CIRCUITS. EXCEPT FOR USE EXPRESSLY GRANTED, IN WRITING, TO ITS VENDORS, VENDEE AND THE UNITED STATES GOVERNMENT, MINI-CIRCUITS RESERVES ALL PROPRIETARY DESIGN, USE, MANUFACTURING AND REPRODUCTION RIGHTS THERETO. THESE CONTENTS SHALL NOT BE USED, DUPLICATED OR DISCLOSED TO ANY OUTSIDE PARTY, IN WHOLE OR IN PART, WITHOUT WRITTEN PERMISSION OF MINI-CIRCUITS.

Evaluation Board and Circuit

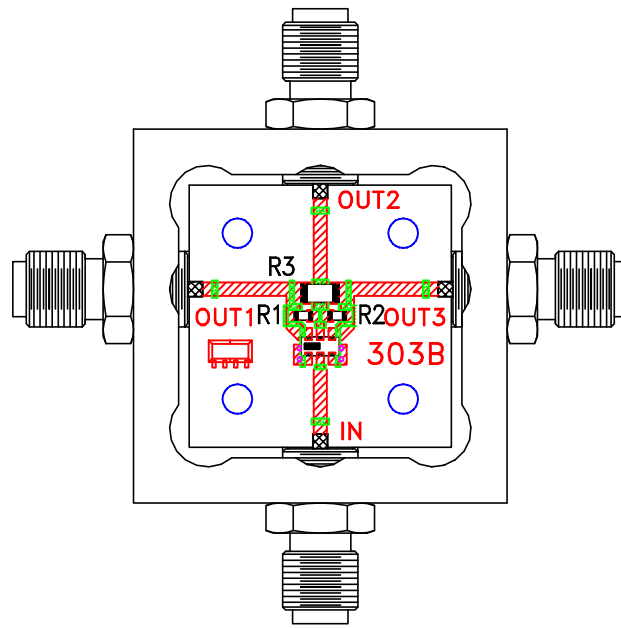

TB-303

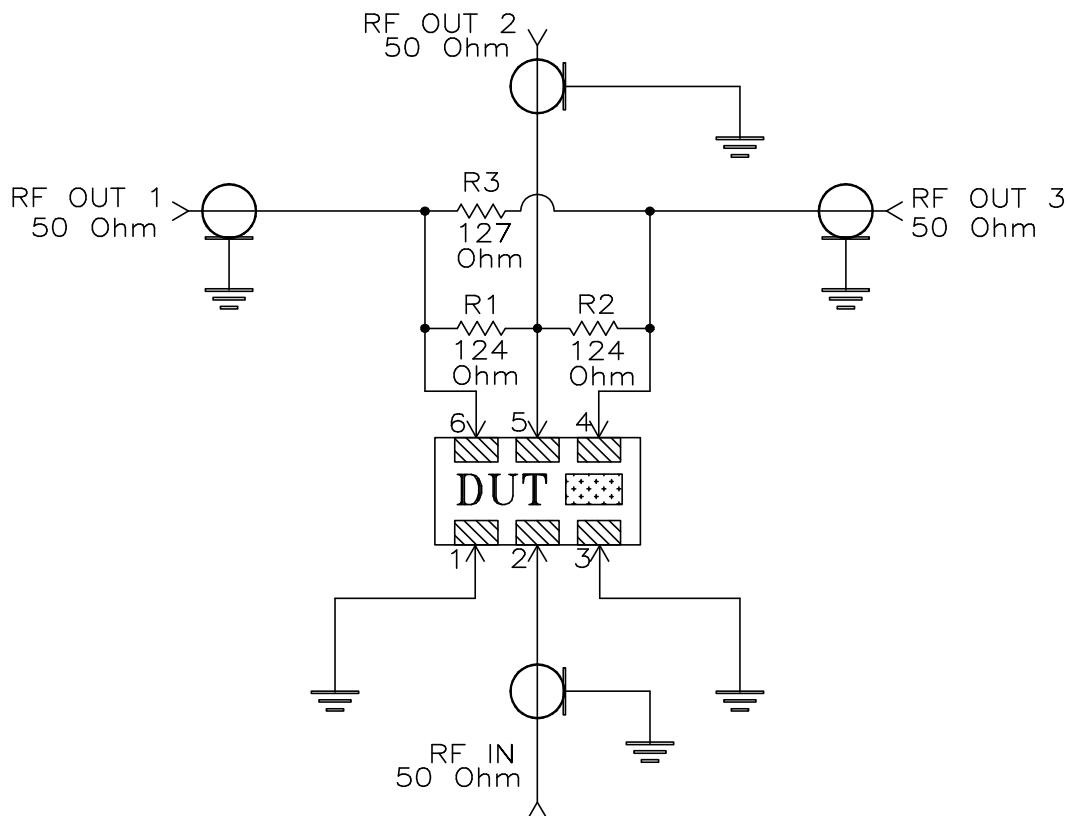

Schematic Diagram

Notes:

1. SMA Female connectors.
2. PCB Material: Rogers R04350 or equivalent,
Dielectric Constant=3.5, Thickness=.020 inch.

 **Mini-Circuits®**

All Mini-Circuits products are manufactured under exacting quality assurance and control standards, and are capable of meeting published specifications after being subjected to any or all of the following physical and environmental test.

Specification	Test/Inspection Condition	Reference/Spec
Operating Temperature	-55° to 100°C Ambient Environment	Individual Model Data Sheet
Storage Temperature	-55° to 100° C Ambient Environment	Individual Model Data Sheet
Humidity	90 to 95% RH, 240 hours, 50°C	MIL-STD-202, Method 103, Condition A, Except 50°C and end-point electrical test done within 12 hours
Solder Reflow Heat	Sn-Pb Eutetic Process: 225°C peak Pb-Free Process 245° - 250°C peak	J-STD-020, Table 4-1, 4-2 and 5-2, Figure 5-1
Solderability	10X Magnification	J-STD-002, Para 4.2.5, Test S, 95% Coverage
Vibration (High Frequency)	20g peak, 10-2000 Hz, 12 times in each of three perpendicular directions (total 36)	MIL-STD-202, Method 204, Condition D
Mechanical Shock	50g, 11 ms, 1/2-sine, 18 shocks: 3 each direction, each of 3 axes	MIL-STD-202, Method 213, Condition A