



COAXIAL

Adapter

SFR-KF50+

50Ω DC to 18 GHz Right-Angle SMA Female to 2.92 mm Female

THE BIG DEAL

- Low Insertion Loss, 0.08 dB typ. up to 18 GHz
- Excellent VSWR, 1.16:1 typ. up to 18 GHz
- Low cost adapters, available from stock
- Body brass alloy tri metal plated and gold-plated beryllium copper center connector



Generic photo used for illustration purposes only

Model No.	SFR-KF50+
Case Style	DJ2442-6
Connectors	Right-Angle SMA Female to 2.92 mm SMA Female

+RoHS Compliant

The +Suffix identifies RoHS Compliance. See our website for methodologies and qualifications

APPLICATIONS

- Interconnection of RF cable and equipment

PRODUCT OVERVIEW

Mini-Circuits' SFR-KF50+ is a right-angle SMA female to 2.92 mm female adapter supporting a wide range of applications from DC to 18 GHz. This model provides excellent VSWR, low insertion loss, and flat response versus frequency. The SFR-KF50+ features brass alloy tri metal plated body and Gold-plated beryllium copper construction center contact.

KEY FEATURES

Feature	Advantages
Wideband, DC to 18 GHz	Wide frequency range provides application flexibility and makes this model ideal for broadband and multi-band use.
Excellent VSWR <ul style="list-style-type: none"> • 1.12:1 typ. up to 18 GHz 	Provides good matching for 50Ω systems and minimizes signal reflections across wide frequency range.
Low insertion loss <ul style="list-style-type: none"> • 0.08 dB typ. up to 18 GHz 	Provides excellent signal power transmission from input to output.
Brass alloy tri metal plated body and Gold-plated beryllium copper center contact	Stands up to wear and tear in demanding environments and provides excellent reliability.
Very wide operating temperature range <ul style="list-style-type: none"> • -55 to +100 °C 	Withstands extreme operating conditions and is suitable for use near high power componentry where heat rise is common.

REV. A
ECO-016626
SFR-KF50+
MCL NY
260413





COAXIAL

Adapter

SFR-KF50+

50Ω DC to 18 GHz Right-Angle SMA Female to 2.92 mm Female

ELECTRICAL SPECIFICATIONS AT +25 °C

Parameter	Condition (GHz)	Min.	Typ.	Max.	Units
Frequency Range		DC		18	GHz
Insertion Loss	DC-18	-	0.08	-	dB
VSWR	DC-8	-	1.03	1.25	:1
	8-12	-	1.09	1.25	
	12-18	-	1.11	1.25	

ABSOLUTE MAXIMUM RATINGS

Parameter	Ratings
Operating Temperature	-55 °C to +100 °C
Storage Temperature	-55 °C to +100 °C

Permanent damage may occur if any of these limits are exceeded.

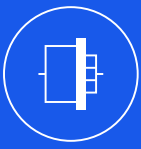

COAXIAL

Adapter

SFR-KF50+

Mini-Circuits

50Ω DC to 18 GHz Right-Angle SMA Female to 2.92 mm Female

OUTLINE DRAWING

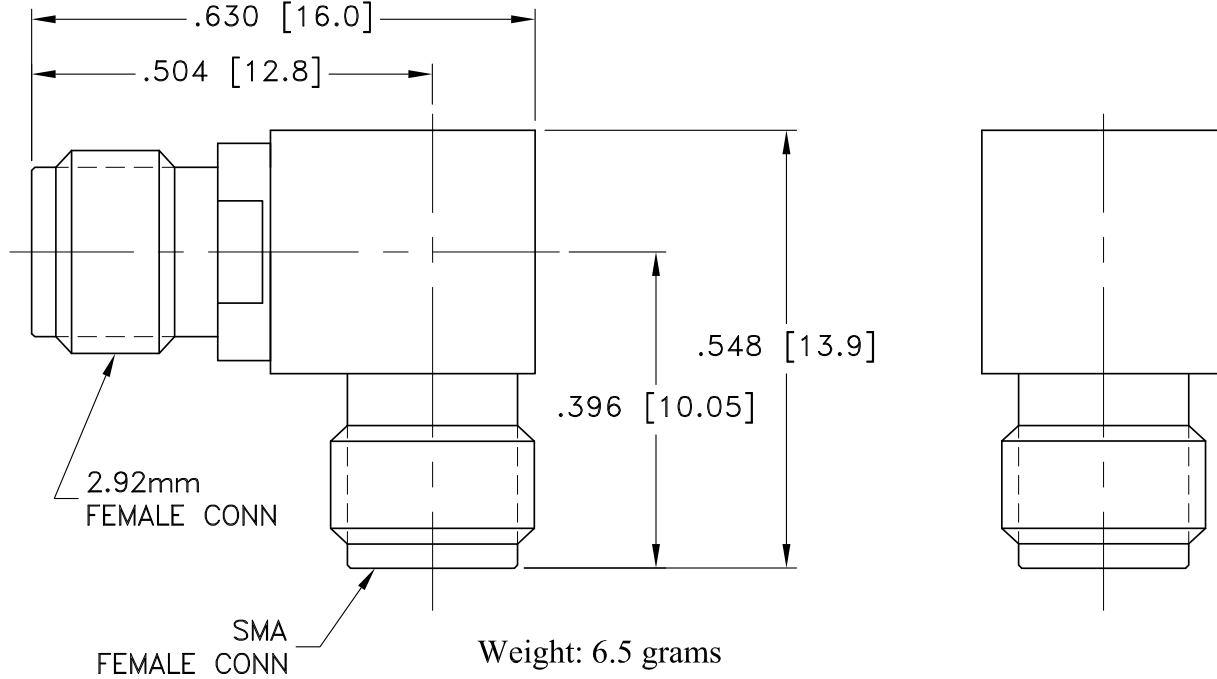

Dimensions are in inches [mm]. Tolerances: 2 Pl.±.03; 3 Pl. ±.015

Note: Parts may be marked as SFR-SF50+ or as SFR-KF50+



COAXIAL

Adapter

SFR-KF50+

50Ω DC to 18 GHz Right-Angle SMA Female to 2.92 mm Female

TYPICAL PERFORMANCE DATA

Frequency (MHz)	Insertion Loss (dB)	VSWR (:1)	
		Right-Angle SMA Female	2.92 mm Female
10	0.01	1.02	1.02
100	0.01	1.01	1.01
1000	0.05	1.02	1.02
2000	0.05	1.03	1.02
4000	0.06	1.03	1.02
6000	0.06	1.04	1.04
8000	0.06	1.04	1.04
9000	0.06	1.04	1.04
10000	0.06	1.08	1.08
11000	0.08	1.12	1.12
12000	0.08	1.15	1.16
15000	0.06	1.08	1.08
16000	0.06	1.02	1.02
18000	0.07	1.11	1.12

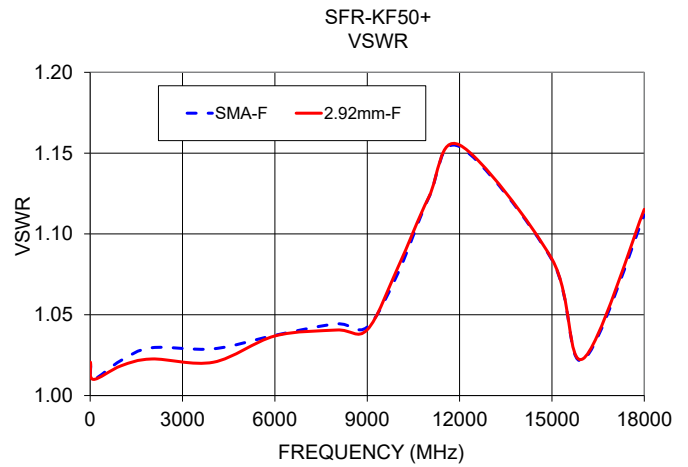
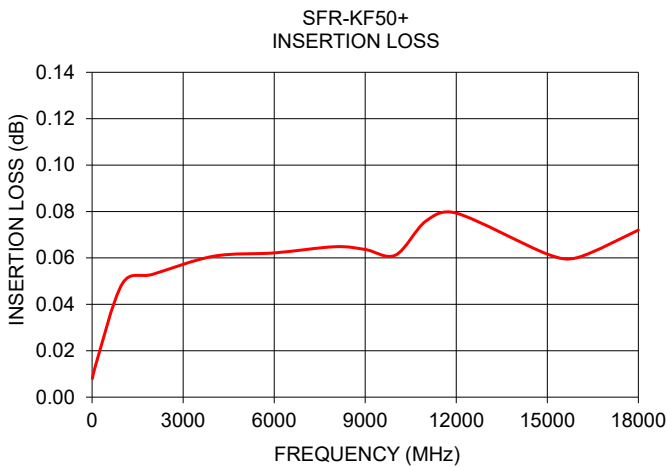

NOTES

- A. Performance and quality attributes and conditions not expressly stated in this specification document are intended to be excluded and do not form a part of this specification document.
- B. Electrical specifications and performance data contained in this specification document are based on Mini-Circuit's applicable established test performance criteria and measurement instructions.
- C. The parts covered by this specification document are subject to Mini-Circuits standard limited warranty and terms and conditions (collectively, "Standard Terms"); Purchasers of this part are entitled to the rights and benefits contained therein. For a full statement of the standard terms and the exclusive rights and remedies thereunder, please visit Mini-Circuits' website at www.minicircuits.com/terms/viewterm.html



Typical Performance Data

FREQUENCY (MHz)	INSERTION LOSS (dB)	SMA-FEMALE VSWR (:1)	2.92mm-FEMALE VSWR (:1)
10	0.001	1.02	1.02
20	0.017	1.01	1.01
30	0.016	1.00	1.00
40	0.022	1.00	1.00
50	0.018	1.00	1.00
60	0.016	1.00	1.00
70	0.020	1.00	1.00
80	0.016	1.00	1.00
90	0.016	1.01	1.00
100	0.018	1.00	1.00
500	0.041	1.01	1.01
1000	0.051	1.02	1.02
1500	0.056	1.03	1.02
2000	0.058	1.03	1.02
2500	0.062	1.03	1.02
3000	0.064	1.03	1.02
3500	0.065	1.03	1.02
4000	0.066	1.03	1.02
4500	0.068	1.03	1.02
5000	0.070	1.03	1.03
5500	0.066	1.03	1.03
6000	0.063	1.04	1.04
6500	0.066	1.04	1.04
7000	0.067	1.05	1.04
7500	0.067	1.05	1.04
8000	0.065	1.04	1.04
8500	0.067	1.04	1.03
9000	0.065	1.04	1.04
9500	0.067	1.05	1.06
10000	0.064	1.08	1.08
10500	0.069	1.10	1.10
11000	0.079	1.12	1.12
11500	0.077	1.14	1.14
12000	0.083	1.15	1.16
12500	0.087	1.16	1.17
13000	0.086	1.16	1.17
13500	0.087	1.16	1.16
14000	0.075	1.14	1.14
14500	0.071	1.11	1.12
15000	0.067	1.08	1.08
15500	0.063	1.05	1.05
16000	0.060	1.02	1.02
16500	0.062	1.02	1.02
17000	0.065	1.05	1.05
17500	0.070	1.09	1.08
18000	0.078	1.11	1.12

Typical Performance Curves

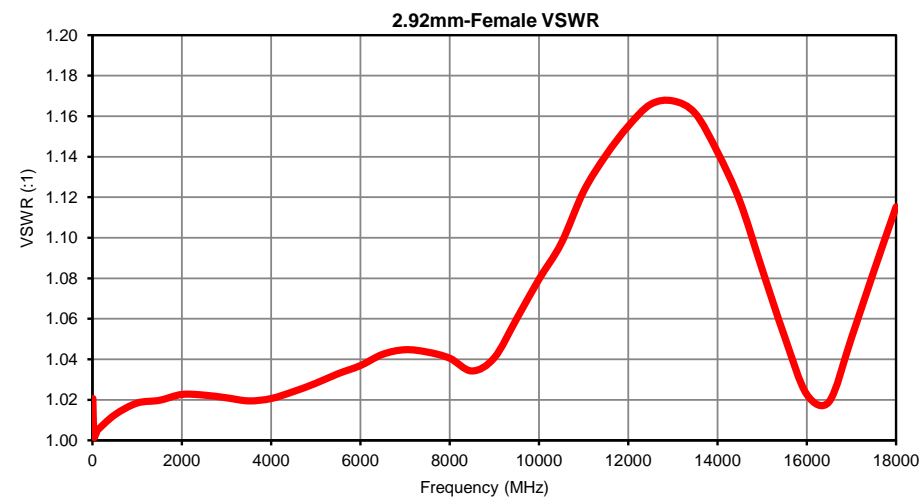
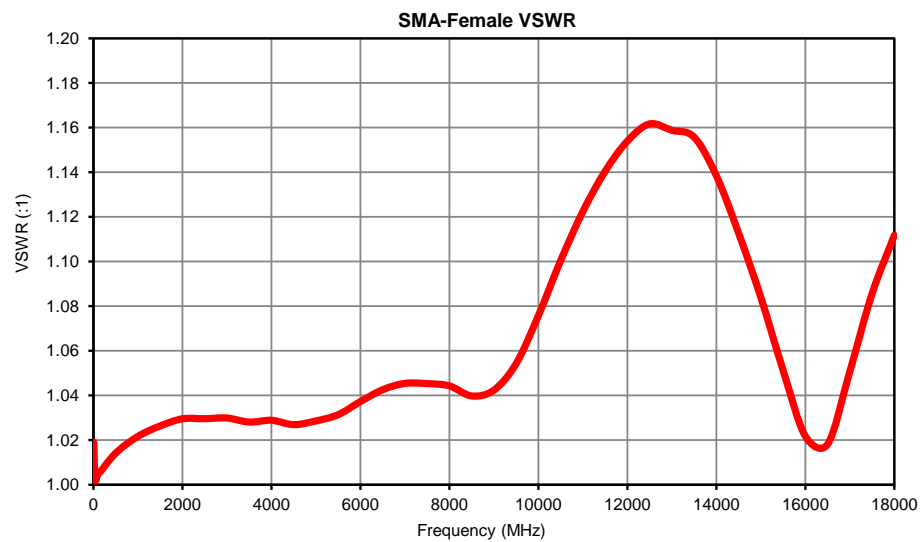

Outline Dimensions

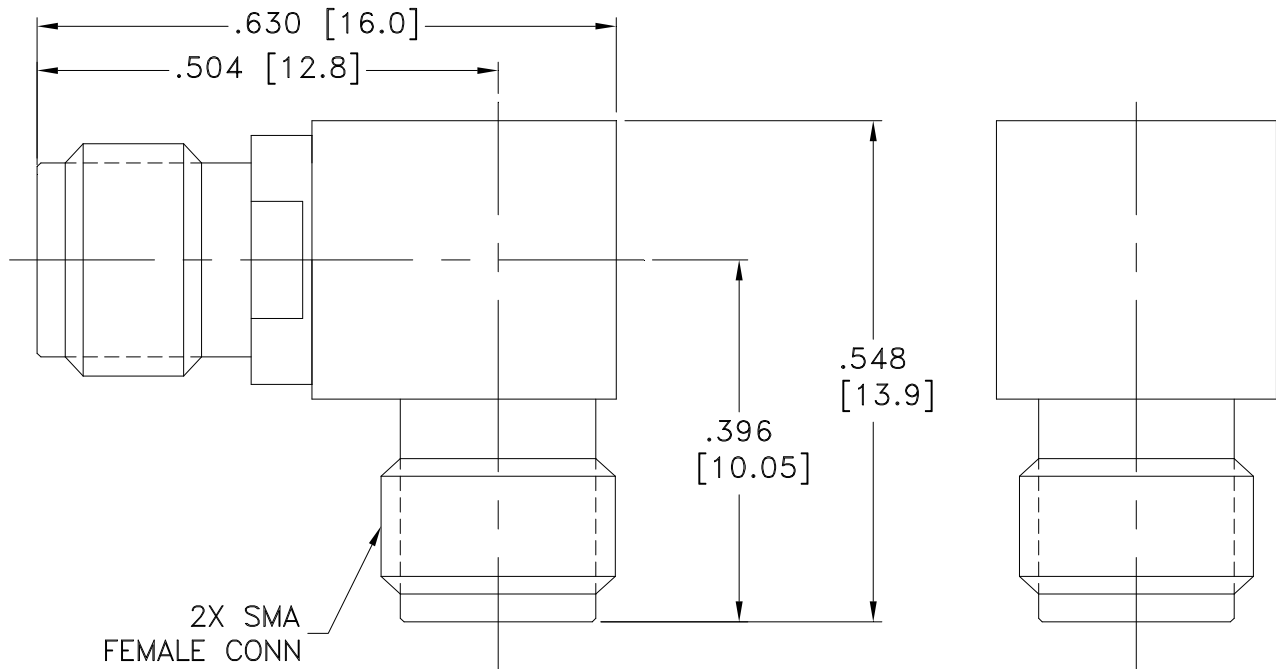

Weight: 6.5 gram

Dimensions are in inches (mm). Tolerances: 2 Pl. \pm .030; 3Pl. + .015

Note:

1. Case material: Brass Alloy
2. Finish: Tri Metal



P.O. Box 350166, Brooklyn, New York 11235-0003 (718) 934-4500 Fax (718) 332-4661 For detailed performance specs & shopping online see Mini-Circuits web site



The Design Engineers Search Engine Provides ACTUAL Data Instantly From MINI-CIRCUITS At: www.minicircuits.com

RF/IF MICROWAVE COMPONENTS

All Mini-Circuits products are manufactured under exacting quality assurance and control standards, and are capable of meeting published specifications after being subjected to any or all of the following physical and environmental test.

Specification	Test/Inspection Condition	Reference/Spec
Operating Temperature	-55° to 100°C Ambient Environment	Individual Model Data Sheet
Storage Temperature	-55° to 100° C Ambient Environment	Individual Model Data Sheet
Barometric Pressure	100,000 Feet	MIL-STD-202, Method 105, Condition D
Humidity	90% RH, 65°C Units may require bake-out after humidity to restore full performance.	MIL-STD-202, Method 103
Thermal Shock	-65° to 125°C, 5 cycles	MIL-STD-202, Method 107, Condition B
Vibration (High Frequency)	20g peak, 10-2000 Hz, 12 times in each of three perpendicular directions (total 36)	MIL-STD-202, Method 204, Condition D
Mechanical Shock	100g, 6ms sawtooth, 3 shocks each direction 3 axes (total 18)	MIL-STD-202, Method 213, Condition I