

Surface Mount Bandpass Filter

SYBP-232+

50Ω 2250 to 2500 MHz

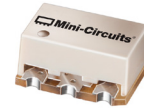

CASE STYLE: TT1423

Features

- High power handling
- Small size
- Temperature stable
- Excellent rejection

Applications

- Military radio
- Lab use

Electrical Specifications at 25°C

Parameter	F#	Frequency (MHz)	Min.	Typ.	Max.	Unit
Pass Band	Center Frequency	—	—	2300	—	MHz
	Insertion Loss	F1-F2	2250 - 2500	2.0	2.9	dB
	VSWR	F1-F2	2250 - 2500	1.8	2.5	:1
Stop Band, Lower	Insertion Loss	DC-F3	DC - 1520	20	23	dB
	VSWR	DC-F3	DC - 1520	—	15	:1
Stop Band, Upper	Insertion Loss	F4-F5	3720 - 4800	20	25	dB
	VSWR	F4-F5	3720 - 4800	—	10	:1

Maximum Ratings

Operating Temperature	-40°C to 85°C
Storage Temperature	-55°C to 100°C
RF Power Input	7W* max. at 25°C

*Passband rating, derate linearly to 3W at 85°C ambient
Permanent damage may occur if any of these limits are exceeded.

Functional Schematic

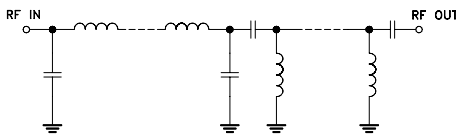

Typical Frequency Response

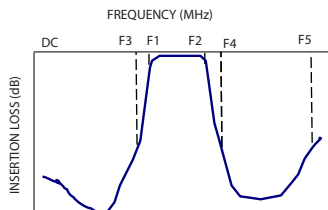

+RoHS Compliant

The +Suffix identifies RoHS Compliance. See our web site for RoHS Compliance methodologies and qualifications

Typical Performance Data at 25°C

Frequency (MHz)	Insertion Loss (dB)	VSWR (:1)
1.00	96.25	107689.00
500.00	62.12	35.24
1100.00	35.95	18.48
1520.00	26.94	14.37
2000.00	6.40	4.75
2250.00	2.37	1.77
2500.00	2.26	1.67
2700.00	2.82	2.57
3000.00	2.61	2.31
3400.00	11.93	9.45
3720.00	29.70	8.62
4000.00	24.38	8.94
4520.00	46.99	15.20
4680.00	36.39	16.43
4800.00	32.49	17.04

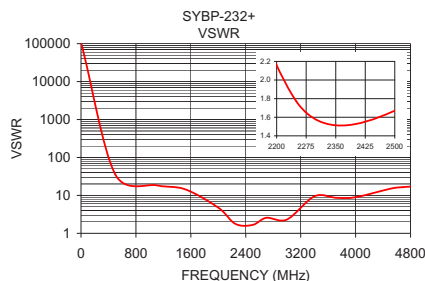
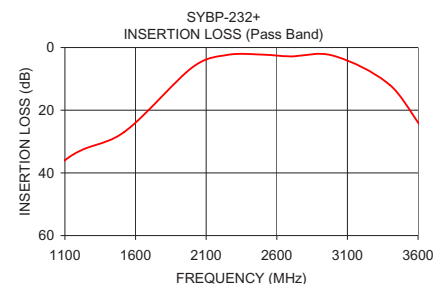
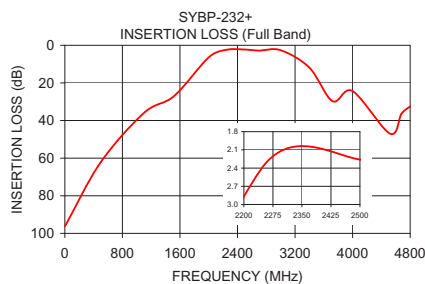

Notes

- Performance and quality attributes and conditions not expressly stated in this specification document are intended to be excluded and do not form a part of this specification document.
- Electrical specifications and performance data contained in this specification document are based on Mini-Circuit's applicable established test performance criteria and measurement instructions.
- The parts covered by this specification document are subject to Mini-Circuits standard limited warranty and terms and conditions (collectively, "Standard Terms"); Purchasers of this part are entitled to the rights and benefits contained therein. For a full statement of the Standard Terms and the exclusive rights and remedies thereunder, please visit Mini-Circuits' website at www.minicircuits.com/MCLStore/terms.jsp





Pin Connections

RF IN	4
RF OUT	6
GROUND	1,2,3,5

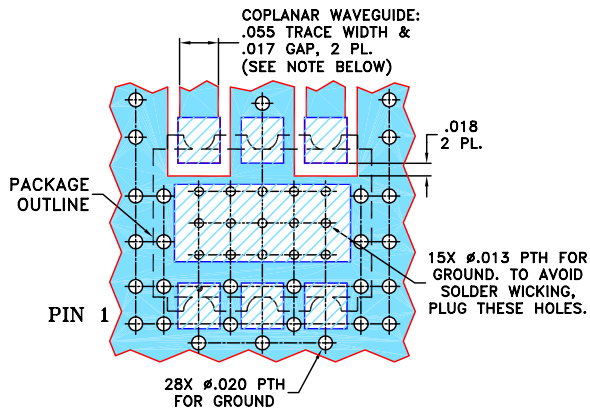
Demo Board MCL P/N: TB-517+
Suggested PCB Layout (PL-308)



NOTES:

- COPLANAR WAVEGUIDE PARAMETERS ARE SHOWN FOR ROGERS R04350B WITH THICKNESS $.030 \pm .002$; COPPER: 1/2 OZ. EACH SIDE. FOR OTHER MATERIALS TRACE WIDTH AND GAP MAY NEED TO BE MODIFIED.
 - BOTTOM SIDE OF THE PCB IS CONTINUOUS GROUND PLANE.
-  DENOTES PCB COPPER LAYOUT WITH SMOBC (SOLDER MASK OVER BARE COPPER)
-  DENOTES COPPER LAND PATTERN FREE OF SOLDER MASK

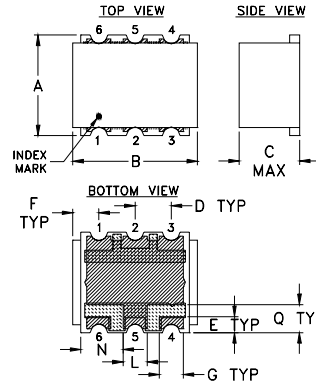

Outline Drawing

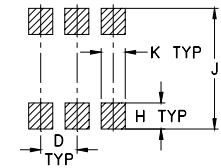

PCB Land Pattern



Suggested Layout,
Tolerance to be within ± 0.002

-  METALLIZATION
-  SOLDER RESIST

Outline Dimensions (inch)

A	B	C	D	E	F	G	H
.25	.31	.15	.090	.040	.065	.060	.065
6.35	7.87	3.81	2.29	1.02	1.65	1.52	1.65
J	K	L	N	Q	wt.		
.300	.060	.060	.105	.070	grams		
7.62	1.52	1.52	2.67	1.78	0.50		

Notes

- Performance and quality attributes and conditions not expressly stated in this specification document are intended to be excluded and do not form a part of this specification document.
- Electrical specifications and performance data contained in this specification document are based on Mini-Circuit's applicable established test performance criteria and measurement instructions.
- The parts covered by this specification document are subject to Mini-Circuits' standard limited warranty and terms and conditions (collectively, "Standard Terms"); Purchasers of this part are entitled to the rights and benefits contained therein. For a full statement of the Standard Terms and the exclusive rights and remedies thereunder, please visit Mini-Circuits' website at www.minicircuits.com/MCLStore/terms.jsp

Typical Performance Data

FREQ. (MHz)	INSERTION LOSS (dB)	INPUT RETURN LOSS (dB)	OUTPUT RETURN LOSS (dB)
1.0	96.25	0.00	0.00
10.0	79.56	0.00	0.00
50.0	65.25	0.01	0.01
100.0	59.62	0.04	0.01
200.0	55.07	0.12	0.04
300.0	54.24	0.23	0.07
400.0	56.43	0.36	0.11
500.0	62.12	0.49	0.16
600.0	54.01	0.61	0.21
700.0	47.76	0.71	0.26
800.0	43.18	0.80	0.32
900.0	40.02	0.85	0.37
1100.0	35.95	0.94	0.48
1200.0	34.53	0.98	0.54
1400.0	30.93	1.09	0.66
1500.0	27.73	1.19	0.74
1520.0	26.94	1.21	0.76
1550.0	25.70	1.25	0.79
1600.0	23.45	1.34	0.85
1700.0	18.64	1.57	1.03
1800.0	13.88	1.94	1.36
1900.0	9.69	2.57	2.00
2000.0	6.40	3.71	3.18
2100.0	4.13	5.69	5.06
2200.0	2.77	8.90	7.68
2210.0	2.68	9.31	7.97
2220.0	2.59	9.74	8.27
2230.0	2.51	10.17	8.57
2240.0	2.44	10.62	8.86
2250.0	2.37	11.09	9.16
2260.0	2.31	11.57	9.44
2280.0	2.21	12.54	9.99
2300.0	2.12	13.49	10.47
2320.0	2.07	14.34	10.86
2340.0	2.03	14.92	11.13
2350.0	2.02	15.06	11.20
2360.0	2.01	15.08	11.23
2370.0	2.01	15.01	11.22
2380.0	2.00	14.84	11.18
2390.0	2.01	14.59	11.10
2400.0	2.02	14.28	10.99
2420.0	2.04	13.54	10.68
2440.0	2.08	12.72	10.31
2450.0	2.11	12.30	10.12
2460.0	2.13	11.90	9.91
2470.0	2.16	11.51	9.71
2480.0	2.19	11.14	9.50
2490.0	2.22	10.79	9.30
2500.0	2.26	10.45	9.11
2600.0	2.61	8.04	7.61
2800.0	2.73	7.49	8.36
3000.0	2.61	9.74	17.02
3200.0	6.24	3.39	3.94
3400.0	11.93	1.84	2.09
3500.0	15.35	1.74	1.99
3600.0	19.99	1.82	2.09
3720.0	29.70	2.02	2.30
3750.0	32.21	2.07	2.35
3800.0	30.99	2.12	2.40
3900.0	25.78	2.10	2.41
4000.0	24.38	1.95	2.29
4200.0	27.11	1.54	1.91
4400.0	35.64	1.24	1.63
4500.0	45.06	1.16	1.54
4520.0	46.99	1.14	1.52
4600.0	41.58	1.10	1.48
4680.0	36.39	1.06	1.45
4800.0	32.49	1.02	1.43



Typical Performance Curves

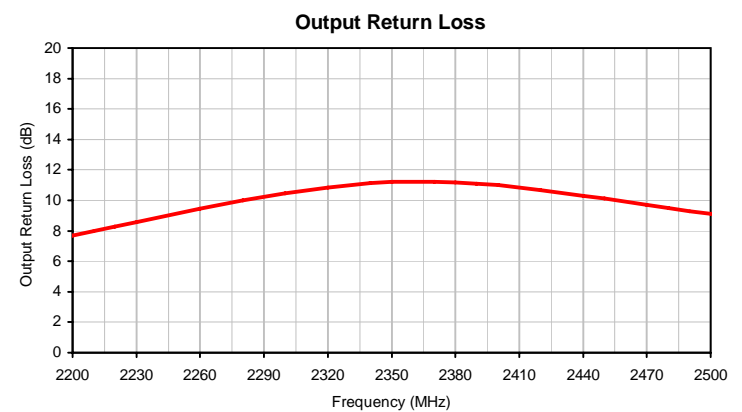
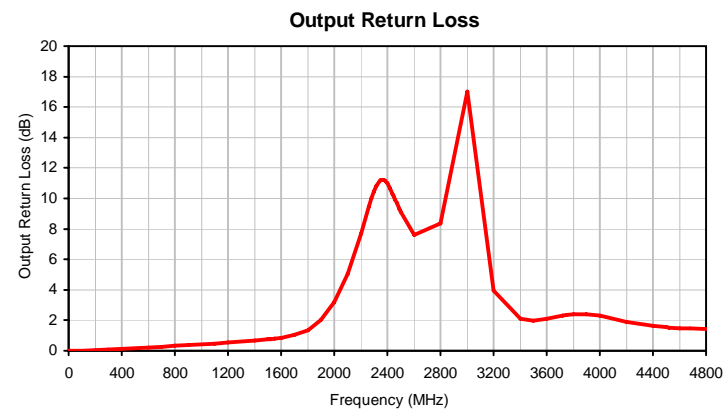
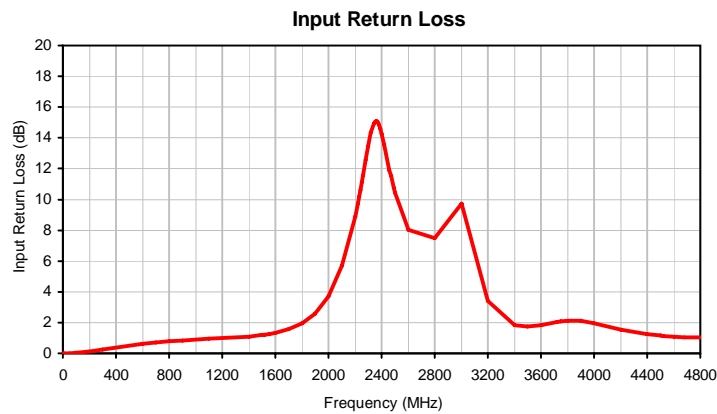
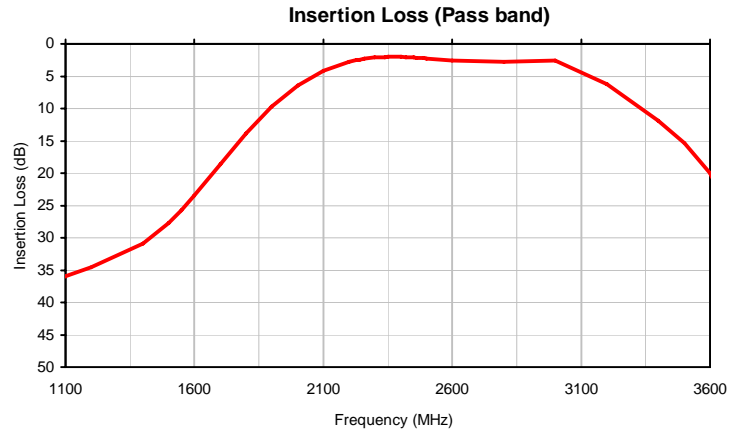
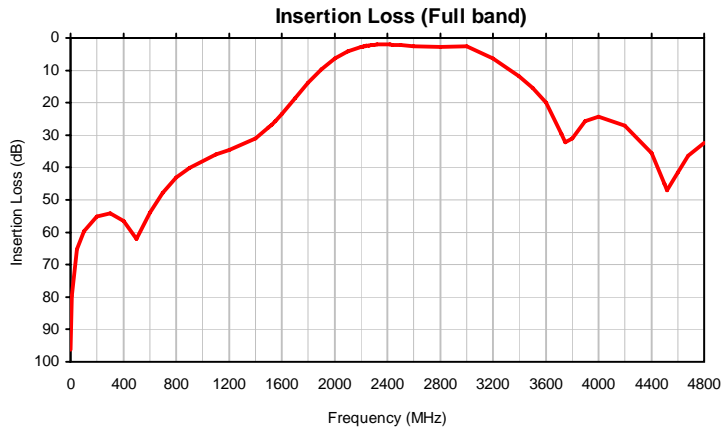

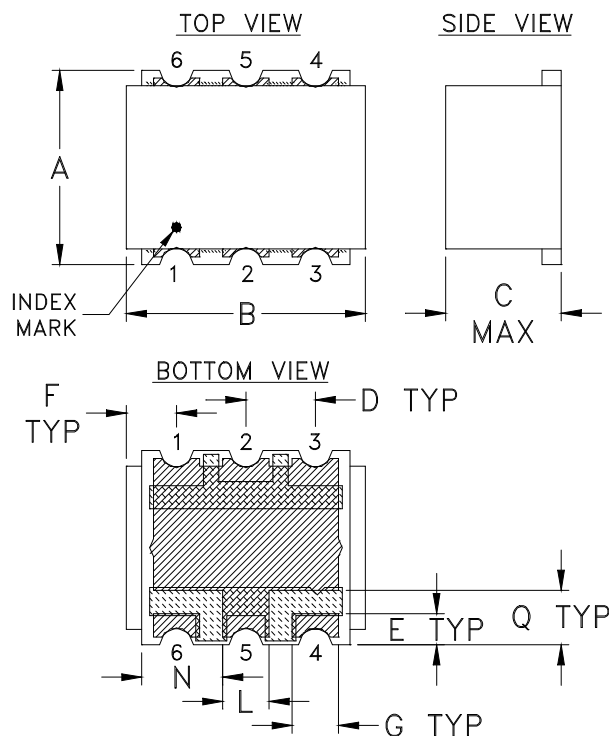

Outline Dimensions

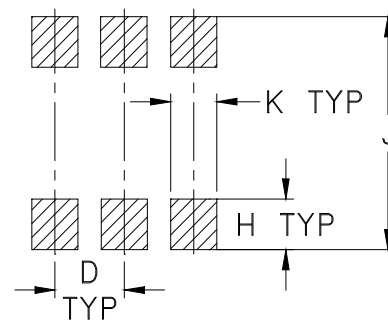

PCB Land Pattern



Suggested Layout,
Tolerance to be within ± 0.002

 METALLIZATION
 SOLDER RESIST

CASE #	A	B	C	D	E	F	G	H	J	K	L	M
TT1423	.25 (6.35)	.31 (7.87)	.15 (3.81)	.090 (2.29)	.040 (1.02)	.065 (1.65)	.060 (1.52)	.065 (1.65)	.300 (7.62)	.060 (1.52)	.060 (1.52)	- -

CASE #	N	P	Q	WT. GRAM
TT1423	.105 (2.67)	- -	.070 (1.78)	.50

Dimensions are in inches (mm). Tolerances: 2Pl. $\pm .01$; 3 Pl. $\pm .005$

Notes:

- Case material: Plastic.
- Terminations: 2-10 μ inch (.05-.25 microns) Gold over 100-300 μ inch (2.54-7.62 microns) Nickel plate.



P.O. Box 350166, Brooklyn, New York 11235-0003 (718) 934-4500 Fax (718) 332-4661 For detailed performance specs & shopping online see Mini-Circuits web site



The Design Engineers Search Engine Provides ACTUAL Data Instantly From MINI-CIRCUITS At: www.minicircuits.com

RF/IF MICROWAVE COMPONENTS

Tape & Reel Packaging TR-F2

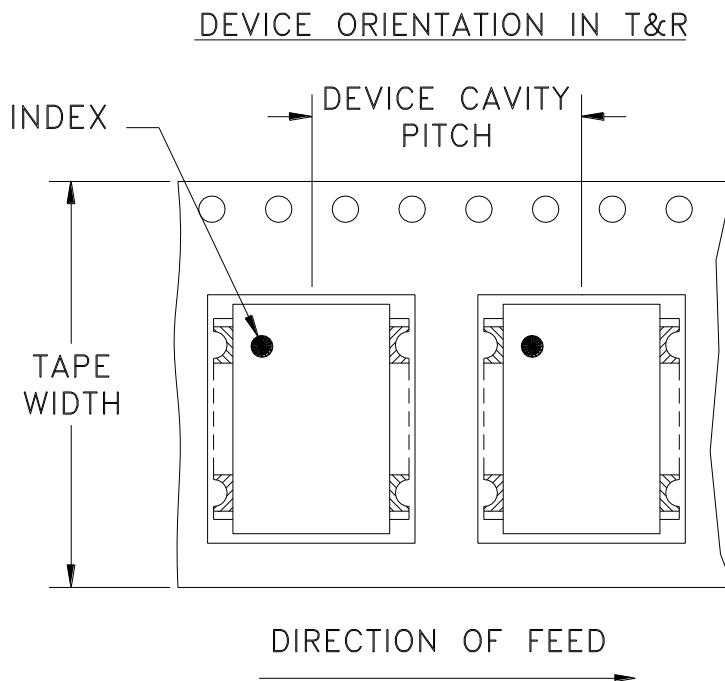

Tape Width, mm	Device Cavity Pitch, mm	Reel Size, inches	Devices per Reel See note
16	12	7	10
			20
			50
			100
			200
		13	500

Note: Please consult individual model data sheet to determine device per reel availability

Mini-Circuits carrier tape materials provide protection from ESD (Electro-Static Discharge) during handling and transportation. Tapes are static dissipative and comply with industry standards EIA-481/EIA-541.

Go to: www.minicircuits.com/pages/pdfs/tape.pdf



INTERNET <http://www.minicircuits.com>

P.O. Box 350166, Brooklyn, New York 11235-0003 (718) 934-4500 Fax (718) 332-4661

Distribution Centers NORTH AMERICA 800-654-7949 • 417-335-5935 • Fax 417-335-5945 • EUROPE 44-1252-832600 • Fax 44-1252-837010

Mini-Circuits ISO 9001 & ISO 14001 Certified

THIRD ANGLE PROJECTION

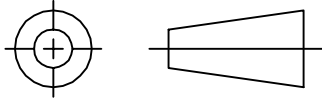

REVISIONS

REV	ECN No.	DESCRIPTION	DATE	DR	AUTH
OR	M123346	NEW RELEASE	07/10/09	AV	DY

**SUGGESTED MOUNTING CONFIGURATION
FOR TT1423 CASE STYLE "06FL04" PIN CONNECTION**

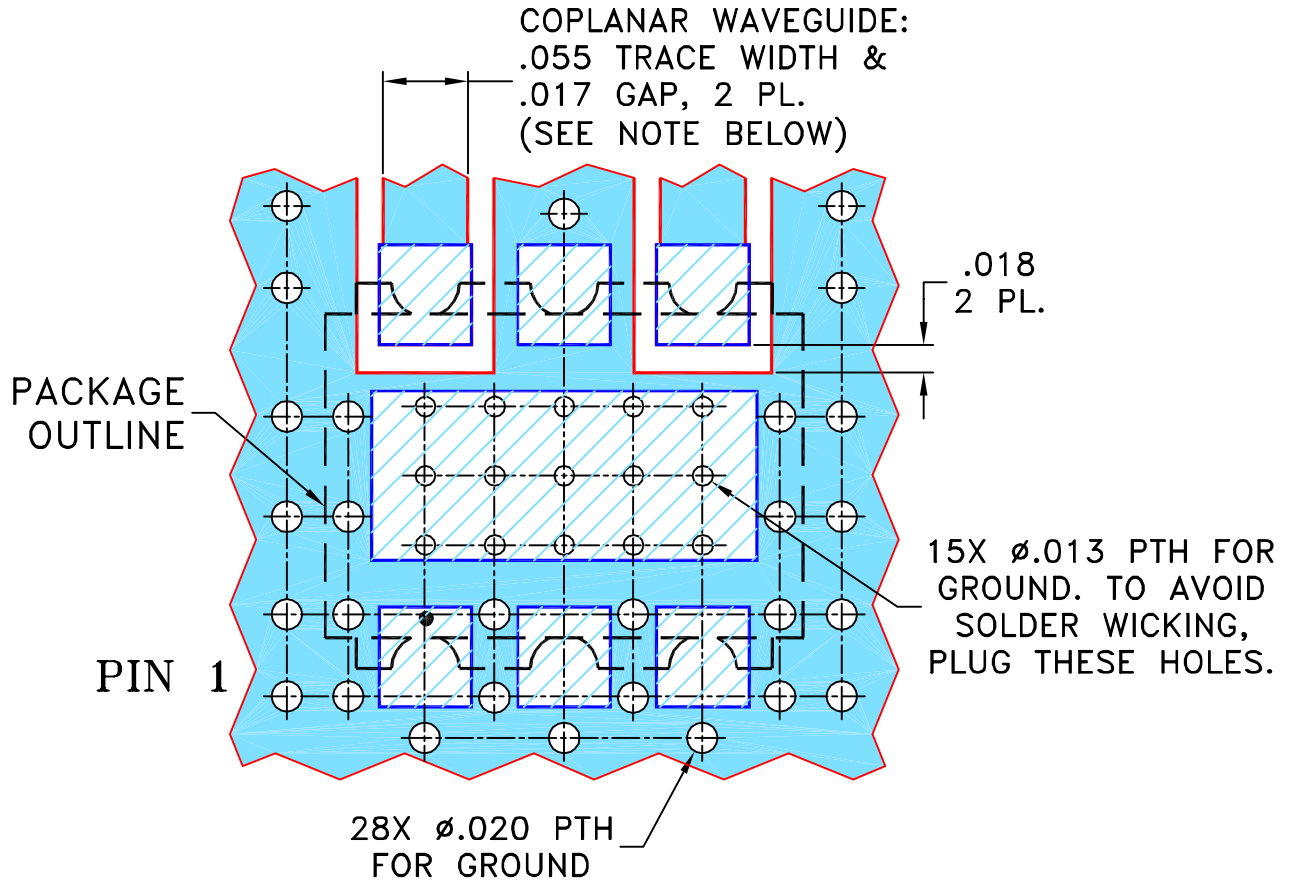

NOTES:

1. COPLANAR WAVEGUIDE PARAMETERS ARE SHOWN FOR ROGERS RO4350B WITH THICKNESS .030" \pm .002"; COPPER: 1/2 OZ. EACH SIDE. FOR OTHER MATERIALS TRACE WIDTH AND GAP MAY NEED TO BE MODIFIED.
2. BOTTOM SIDE OF THE PCB IS CONTINUOUS GROUND PLANE.



DENOTES PCB COPPER LAYOUT WITH SMOBC
(SOLDER MASK OVER BARE COPPER)

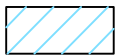

DENOTES COPPER LAND PATTERN FREE OF SOLDER MASK

UNLESS OTHERWISE SPECIFIED

DIMENSIONS ARE IN INCHES
TOLERANCES ON:
2 PL DECIMALS \pm
3 PL DECIMALS \pm .005
ANGLES \pm
FRACTIONS \pm

	INITIALS	DATE
DRAWN	AV	06/22/09
CHECKED	IL	07/10/09
APPROVED	DY	07/10/09



Mini-Circuits[®]

13 Neptune Avenue
Brooklyn NY 11235

PL, 06FL04, TT1423, SYBP, TB-517+

Mini-Circuits[®]
THIS DOCUMENT AND ITS CONTENTS ARE THE PROPERTY OF MINI-CIRCUITS. EXCEPT FOR USE EXPRESSLY GRANTED, IN WRITING, TO ITS VENDORS, VENDEE AND THE UNITED STATES GOVERNMENT, MINI-CIRCUITS RESERVES ALL PROPRIETARY DESIGN, USE, MANUFACTURING AND REPRODUCTION RIGHTS THERETO. THESE CONTENTS SHALL NOT BE USED, DUPLICATED OR DISCLOSED TO ANY OUTSIDE PARTY, IN WHOLE OR IN PART, WITHOUT WRITTEN PERMISSION OF MINI-CIRCUITS.

ASHEETA1.DWG REV:A DATE:01/12/95

SIZE	CODE IDENT	DRAWING NO:	REV:
A	15542	98-PL-308	OR
FILE:	98PL308	SCALE:	8:1
SHEET:	1	OF	1

Evaluation Board and Circuit

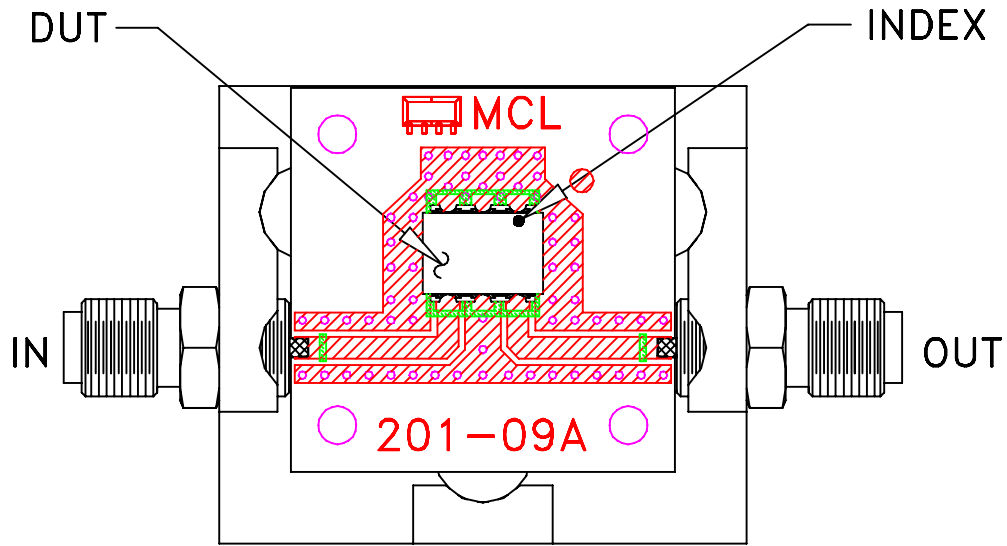

TB-517+

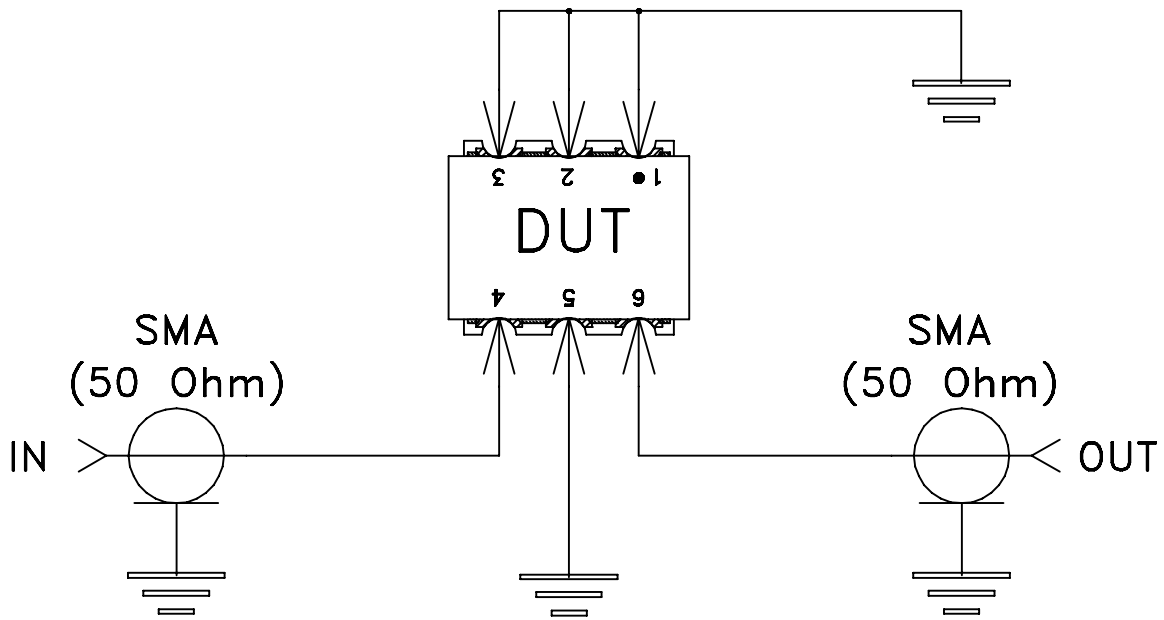

Schematic Diagram

Notes:

1. 50 Ohm SMA Female connectors.
2. PCB Material: R04350 or equivalent,
Dielectric Constant=3.5, Thickness=.020 inch.

 **Mini-Circuits®**

All Mini-Circuits products are manufactured under exacting quality assurance and control standards, and are capable of meeting published specifications after being subjected to any or all of the following physical and environmental test.

Specification	Test/Inspection Condition	Reference/Spec
Operating Temperature	-40° to 85°C Ambient Environment	Individual Model Data Sheet
Storage Temperature	-55° to 100° C Ambient Environment	Individual Model Data Sheet
Humidity	90 to 95% RH, 240 hours, 50°C	MIL-STD-202, Method 103, Condition A, Except 50°C and end-point electrical test done within 12 hours
Thermal Shock	-55° to 100°C, 100 cycles	MIL-STD-202, Method 107, Condition A-3, except +100°C
Solder Reflow Heat	Sn-Pb Eutetic Process: 225°C peak Pb-Free Process 245° - 250°C peak	J-STD-020, Table 4-1, 4-2 and 5-2, Figure 5-1
Solderability	10X Magnification	J-STD-002, 95% Coverage
Vibration (High Frequency)	20g peak, 10-2000 Hz, 12 times in each of three perpendicular directions (total 36)	MIL-STD-202, Method 204, Condition D
Mechanical Shock	50g, 11 ms, 1/2-sine, 18 shocks: 3 each direction, each of 3 axes	MIL-STD-202, Method 213, Condition A
Marking Resistance to Solvents	Isopropyl alcohol + mineral spirits at 25°C; terpene defluxer at 25°C; distilled water + proylene glycol monomethyl ether + monoethanolamine at 63°C to 70°C	MIL-STD-202, Method 215