

Low Noise, Medium Current, High IP3 E-PHEMT Transistor Die

TAV2-501-D+

50Ω 0.4 to 3.9 GHz

The Big Deal

- Single Positive Supply Voltage
- Low Noise Figure, 0.6 dB at 0.9 GHz
- Gain, 15 dB at 2 GHz
- High Output IP3, 43 dBm at 2 GHz
- P1dB, 30.6 dBm at 0.9 GHz, 27.7 dBm at 2 GHz
- External biasing and matching required

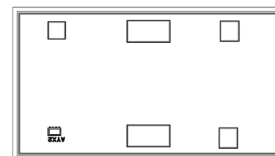

Product Overview

Mini-Circuits' TAV2-501-D+ is a MMIC E-PHEMT* transistor die with an operating frequency range from 0.4 to 3.9 GHz. It has outstanding Noise Figure, particularly below 2.5 GHz, and when combining this noise figure with high IP3 performance in a single device it makes it an ideal amplifier for demanding cellular infrastructure.

Key Features

Feature	Advantages
Wideband, 0.4 to 3.9 GHz	A single device covers many wireless communications bands including cellular, ISM, GSM, WCDMA, WiMax, WLAN, and more.
High IP3 vs. DC power consumption <ul style="list-style-type: none"> • +42.9 dBm at 0.9 GHz • +42.9 dBm at 2 GHz • +43.9 dBm at 3.9 GHz For additional data, see Tables 1-4 on Page 5	The TAV2-501-D+ matches industry leading IP3 performance relative to device size and power consumption. Enhanced linearity over a broad frequency range makes the device ideal for use in: <ul style="list-style-type: none"> • Driver amplifiers for complex waveform up converter paths • Drivers in linearized transmit systems
High P1dB <ul style="list-style-type: none"> • +30.6 dBm at 0.9 GHz • +27.7 dBm at 2 GHz • +30.0 dBm at 3.9 GHz For additional data, see Tables 1-4 on Page 5	Results in a very dynamic range preventing amplifier saturation under strong interfering signals.
Combines high gain (23.5 dB) with very low Noise Figure (0.6 dB)	The unique combination of high gain and low Noise Figure results in lower overall system noise.
Unpackaged Die	Enables the user to integrate the amplifier directly into hybrids

* Enhancement mode Pseudomorphic High Electron Mobility Transistor.

Low Noise, Medium Current, High IP3 E-PHEMT Transistor Die

TAV2-501-D+

Product Features

- Single Positive Supply Voltage
- Low Noise Figure, 0.6 dB at 0.9 GHz
- Gain, 15 dB at 2 GHz
- High Output IP3, 42.9 dBm at 2 GHz
- P1dB, 30.6 dBm at 0.9 GHz, 27.7 dBm at 2 GHz
- External biasing and matching required

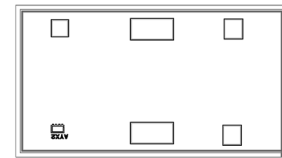

Typical Applications

- Cellular
- ISM
- GSM
- WCDMA
- WiMax
- WLAN

+RoHS Compliant
The +Suffix identifies RoHS Compliance. See our web site for RoHS Compliance methodologies and qualifications

Ordering Information: Refer to Last Page

General Description

Mini-Circuits' TAV2-501-D+ is a MMIC E-PHEMT* transistor die with an operating frequency range from 0.4 to 3.9 GHz. It has outstanding Noise Figure, particularly below 2.5 GHz, and when combining this noise figure with high IP3 performance in a single device it makes it an ideal amplifier for demanding cellular infrastructure.

Simplified Schematic and Pad description

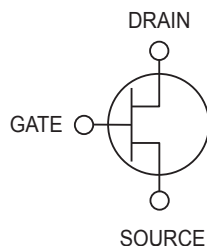

Pad#	Description
1 & 5	GATE used for RF-IN
2 & bottom of die	SOURCE Terminal, normally connected to ground
3 & 4	DRAIN used for RF-OUT

Bonding Pad Position

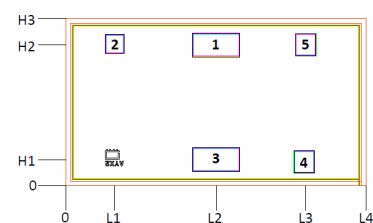

Dimensions in μm , Typical

L1	L2	L3	L4	H1	H2	H3
154	475	759	950	84	446	530

Thickness	Die size	Pad Size 1 & 3	Pad size 2	Pad Size 4 & 5
100	950 x 530	144 x 69	301 x 69	59 x 64

Electrical Specifications at $T_{AMB}=25^{\circ}\text{C}$

Symbol	Parameter	Condition	Min.	Typ.	Max.	Units
DC Specifications						
V_{TH}	Threshold Voltage	$V_{DS}=4.5\text{V}, I_{DS}=28\text{ mA}$		0.38		V
I_{DSS}	Saturated Drain Current	$V_{DS}=4.5\text{V}, V_{GS}=0\text{ V}$	—	0.5	—	μA
G_M	Transconductance	$=4.5\text{V}, G_m = \Delta I_{DS} / \Delta V_{GS}$ $\Delta V_{GS} = V_{GS1} - V_{GS2}$ $V_{GS1} = V_{GS\text{ typ}} - 0.05$ $V_{GS2} = V_{GS\text{ typ}} + 0.05$	—	2600	—	mS
I_{GSS}	Gate leakage Current	$V_{GD} = V_{GS} = -6.7\text{V}$	—	65		μA

RF & DC Specifications, $Z_0=50\text{ Ohms}$					
Parameter	Condition (GHz)	$V_{DS} = 4.5\text{V},$ $I_{DS} = 280\text{mA}$			Units
		Min.	Typ.	Max.	
Gain	0.9		$23.5^{2,4}$		dB
	2.0		15.1^3		
P1dB	0.9		$30.6^{2,4}$		dBm
	2.0		27.7^3		
OIP3 Pout=0dBm/Tone	0.9		$42.9^{2,5}$		dBm
	2.0		42.9^3		
Noise Figure	0.9		0.6^1		dB
	2.0		1.3^3		
Power Added Efficiency	0.9		$45^{2,4}$		dB
	2.0		45^3		
I_{DS}	DC		280		mA
V_{GS}	DC	0.39	0.52	0.65	V

- For measurements at 0.9 GHz, die is packaged in 2x2mm, 8-lead MCLP package and soldered on Mini-Circuits characterization board TB-TAV2-501+ with no optimization.
- For measurements at 0.9 GHz, die is packaged in 2x2 mm, 8-lead MCLP package and soldered on Mini-Circuits characterization board TB-TAV2-501+ with load and source pull test (See Fig. 1).
- For measurements at 2 GHz, die is packaged in 2x2 mm, 8-lead MCLP package and soldered on Mini-Circuits matching circuit test board TB-TAV2-501M+ (See Fig. 2).
- Measurements at 0.9 GHz obtained for optimized P1dB. Die is packaged in 2x2mm, 8-lead MCLP package and soldered on Mini-Circuits characterization board TB-TAV2-501+.
- Measurements at 0.9 GHz obtained for optimized IP3. Die is packaged in 2x2mm, 8-lead MCLP package and soldered on Mini-Circuits characterization board TB-TAV2-501+.

Absolute Maximum Ratings^{1,2,3,6}

Symbol	Parameter	Max.	Units
V_{DS}^7	Drain-Source Voltage	7	V
V_{GS}^7	Gate-Source Voltage at $V_{DS}=4.5\text{V}$	-5 to +0.8	V
I_{DS}^7	Drain Current at $V_{DS}=4\text{V}$	500	mA
I_{GS}	Gate Current	60	μA
P_{DISS}	Total Dissipated Power	2.4	mW
P_{IN}^8	RF Input Power	28	dBm
T_{CH}	Channel Temperature	150	$^{\circ}\text{C}$
T_{OP}	Operating Temperature	-40 to 85	$^{\circ}\text{C}$
T_{STD}	Storage Temperature	-65 to 150	$^{\circ}\text{C}$
θ_{JC}	Thermal Resistance	23	$^{\circ}\text{C/W}$

- Operation of this device above any one of these parameters may cause permanent damage.
- Assumes DC quiescent conditions.
- I_{GS} is limited to $60\mu\text{A}$ during test.

Characterization Test Circuit

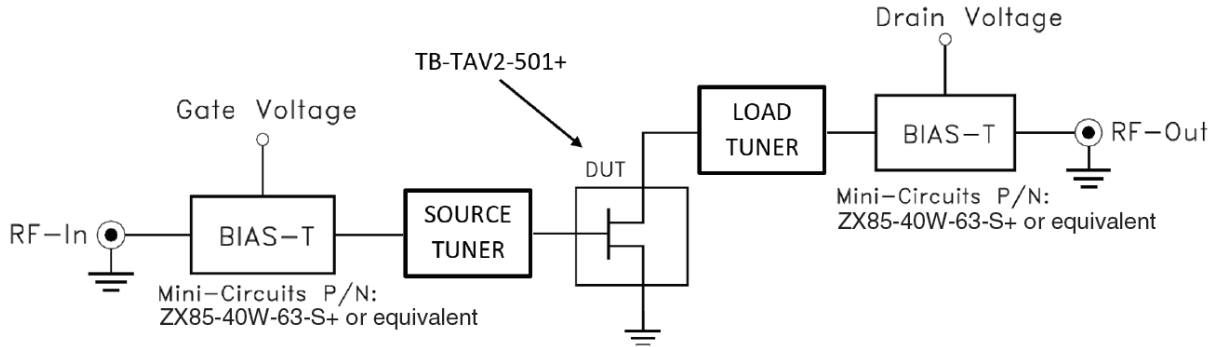

Fig 1. Block Diagram of Test Circuit used for characterization. (Die is packaged in 2x2 mm, 8-lead MCLP package and soldered on Mini-Circuits Test Board TB-TAV2-501+) Gain, Output power at 1dB compression (P1 dB) and output IP3 are measured using Keysight Network Analyzer N5424A PNAx and Maury automated tuner.

Conditions (Optimized IP3):

1. Drain voltage (with reference to source, VDS) = 4.5V as shown.
2. Gate Voltage (with reference to source, VGS) is set to obtain desired Drain-Source current (IDS) as shown in specification table or load and source pull tables.
3. Gain: Pin= -25dBm
4. Pin for IP3: -10 dBm at 0.9 GHz, -5 dBm at 2.0 GHz, -1 dBm at 2.4 GHz, 0 dBm at 3.9 GHz.

Conditions (Optimized P1dB):

1. Drain voltage (with reference to source, VDS) = 4.5V as shown.
2. Gate Voltage (with reference to source, VGS) is set to obtain desired Drain-Source current (IDS) as shown in specification table or load and source pull tables.
3. Gain: Pin= -25dBm
4. Pin for IP3: -10 dBm at 0.9 GHz, -5 dBm at 2.0 GHz and 2.4 GHz, -2 dBm at 3.9 GHz.

Recommended Application Circuit

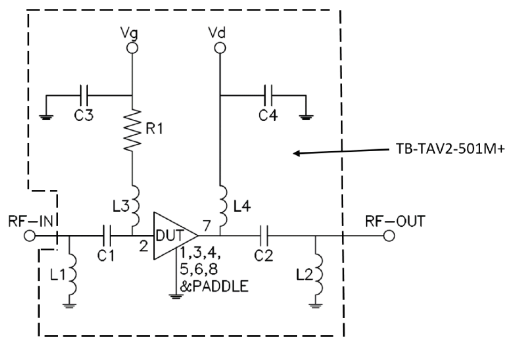

VDS, V (nom)	4.5
IDS, mA (nom)	280
R1	15 Ω
C1	2.4 pF
C2	2.4 pF
C3	2.2 μ F
C4	2.2 μ F
L1	1.2 nH
L2	1.5 nH
L3	15 nH
L4	47 nH

Fig 2. Recommended Application Circuit used for characterization. (Die is packaged in 2x2 mm, 8-lead MCLP package and soldered on Mini-Circuits Matching Circuit Test Board TB-TAV2-501M+)

Table 1: Optimum OIP3 at 4.5 V, 280 mA

Freq (GHz)	OIP3 (dBm)	Gain (dB)	P1dB (dBm)	PAE (%)	Γ_{source}	Γ_{load}
0.9	45.11	19.98	29.85	49.66	0.694 \angle - 114.29°	0.693 \angle - 91.12°
2.0	46.32	14.22	28.68	48.82	0.842 \angle 29.84°	0.715 \angle 35.13°
2.4	44.64	11.23	27.44	42.12	0.724 \angle 123.43°	0.638 \angle 75.56°
3.9	43.89	11.00	27.83	42.76	0.884 \angle - 108.07°	0.679 \angle - 114.78°

Table 2: Optimum P1dB at 4.5 V, 280 mA

Freq (GHz)	OIP3 (dBm)	Gain (dB)	P1dB (dBm)	PAE (%)	Γ_{source}	Γ_{load}
0.9	40.18	22.77	30.03	52.30	0.658 \angle - 87.51°	0.690 \angle - 73.64°
2.0	41.52	17.02	30.23	56.73	0.743 \angle 39.55°	0.715 \angle 43.14°
2.4	41.11	15.10	30.52	53.56	0.742 \angle 92.52°	0.720 \angle 93.56°
3.9	39.53	11.72	29.95	46.67	0.759 \angle - 95.66°	0.687 \angle - 96.87°

Table 3: Optimum OIP3 at 4.5 V, 400 mA

Freq (GHz)	OIP3 (dBm)	Gain (dB)	P1dB (dBm)	PAE (%)	Γ_{source}	Γ_{load}
0.9	47.67	16.84	29.54	50.28	0.645 \angle - 138.14°	0.602 \angle - 69.95°
2.0	45.77	15.97	29.23	50.14	0.649 \angle 40.96°	0.613 \angle 40.33°
2.4	48.05	13.40	29.66	48.74	0.803 \angle 112.01°	0.619 \angle 92.12°
3.9	46.32	11.40	29.57	46.28	0.884 \angle - 108.07°	0.684 \angle - 105.84°

Table 4: Optimum P1dB at 4.5 V, 400 mA

Freq (GHz)	OIP3 (dBm)	Gain (dB)	P1dB (dBm)	PAE (%)	Γ_{source}	Γ_{load}
0.9	42.99	23.04	30.01	45.83	0.658 \angle -87.51°	0.785 \angle - 87.47°
2.0	42.01	18.53	30.68	48.45	0.833 \angle 43.23°	0.827 \angle 42.17°
2.4	44.45	17.26	30.16	55.62	0.874 \angle 94.67°	0.726 \angle 86.88°
3.9	43.13	12.90	30.83	49.36	0.875 \angle -101.14°	0.784 \angle - 99.28°

Assembly Diagram

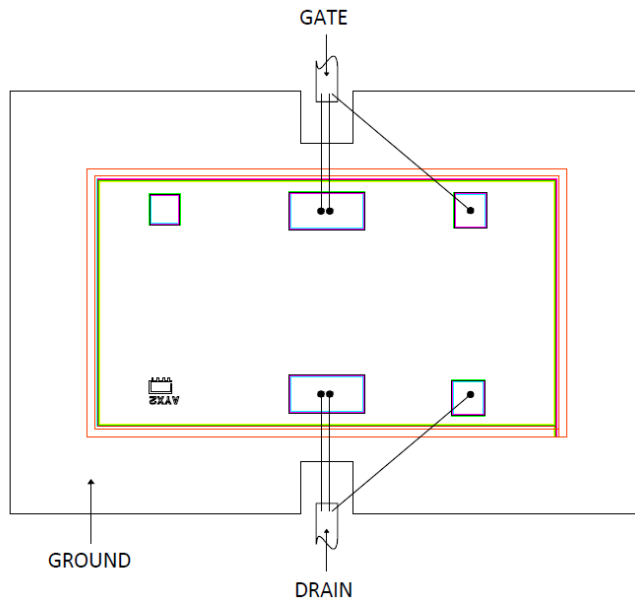

Assembly and Handling Procedure

1. Storage
Dice should be stored in a dry nitrogen purged desiccators or equivalent.
2. ESD
MMIC E-PHEMT transistor dice are susceptible to electrostatic and mechanical damage. Die are supplied in antistatic protected material, which should be opened in clean room conditions at an appropriately grounded anti-static workstation. Devices need careful handling using correctly designed collets, vacuum pickup tips or sharp antistatic tweezers to deter ESD damage to dice.
3. Die Attach
The die mounting surface must be clean and flat. Using conductive silver filled epoxy, recommended epoxies are DieMat DM6030HK-PT/H579 or Ablestik 84-1LMISR4. Apply sufficient epoxy to meet required epoxy bond line thickness, epoxy fillet height and epoxy coverage around total die periphery. Parts shall be cured in a nitrogen filled atmosphere per manufacturer's cure condition. It is recommended to use antistatic die pick up tools only.
4. Wire Bonding
Bond pad openings in the surface passivation above the bond pads are provided to allow wire bonding to the dice gold bond pads. Thermosonic bonding is used with minimized ultrasonic content. Bond force, time, ultrasonic power and temperature are all critical parameters. Suggested wire is pure gold, 1 mil diameter. Bonds must be made from the bond pads on the die to the package or substrate. All bond wires should be kept as short as low as reasonable to minimize performance degradation due to undesirable series inductance.

Typical Performance Data

Definitions:

Input Return Loss = -S11 (dB)

Gain(Power Gain) = S21 (dB)

Reverse Isolation = -S12 (dB)

Output Return Loss = -S22 (dB)

TEST CONDITIONS: Vd = 4.50V, Id = 281mA @ Temperature = +25°C

FREQ (MHz)	Gain (dB)	Isolation (dB)	Input Return Loss (dB)	Output Return Loss (dB)	Stability	
					K	Measure
400	20.17	37.00	0.50	2.30	0.20	0.76
450	19.15	37.03	0.51	2.31	0.25	0.76
500	18.22	37.28	0.53	2.31	0.29	0.76
550	17.39	37.25	0.53	2.31	0.32	0.76
600	16.64	36.94	0.54	2.32	0.34	0.76
650	15.94	37.14	0.56	2.32	0.37	0.76
700	15.29	37.05	0.58	2.33	0.41	0.76
750	14.69	36.86	0.57	2.36	0.44	0.77
800	14.13	37.09	0.59	2.36	0.48	0.77
850	13.62	37.13	0.59	2.34	0.51	0.77
900	13.12	37.25	0.59	2.38	0.56	0.77
950	12.65	36.96	0.60	2.38	0.57	0.77
1000	12.21	37.07	0.61	2.38	0.61	0.77
1050	11.78	36.84	0.62	2.38	0.61	0.78
1100	11.37	36.96	0.63	2.39	0.69	0.78
1150	11.00	36.77	0.63	2.41	0.70	0.78
1200	10.62	36.58	0.64	2.42	0.72	0.78
1250	10.28	36.66	0.64	2.42	0.76	0.78
1300	9.95	36.73	0.65	2.42	0.80	0.78
1350	9.61	36.53	0.66	2.44	0.84	0.78
1400	9.31	36.78	0.65	2.44	0.88	0.79
1450	9.01	36.37	0.66	2.45	0.88	0.79
1500	8.73	36.55	0.67	2.46	0.95	0.79
1550	8.46	36.17	0.67	2.46	0.93	0.79
1600	8.20	36.29	0.67	2.46	0.95	0.79
1650	7.95	36.63	0.68	2.47	1.04	0.79
1700	7.71	36.23	0.68	2.47	1.03	0.79
1750	7.46	36.06	0.67	2.47	1.05	0.79
1800	7.24	36.24	0.68	2.47	1.07	0.79
1850	7.02	36.19	0.68	2.48	1.11	0.79
1900	6.80	35.80	0.68	2.48	1.09	0.79
1950	6.60	35.94	0.68	2.49	1.14	0.79
2000	6.40	35.77	0.68	2.48	1.13	0.79
2050	6.21	35.77	0.68	2.48	1.15	0.79
2100	6.02	35.66	0.68	2.50	1.16	0.80
2150	5.84	35.65	0.68	2.48	1.20	0.79
2200	5.67	35.40	0.67	2.49	1.16	0.80
2250	5.49	35.32	0.67	2.50	1.20	0.80
2300	5.32	35.46	0.66	2.50	1.21	0.80
2350	5.15	35.16	0.67	2.50	1.21	0.80
2400	5.00	35.23	0.66	2.49	1.24	0.80
2450	4.84	35.31	0.66	2.51	1.27	0.80
2500	4.70	35.05	0.66	2.49	1.26	0.80
2550	4.54	35.10	0.65	2.49	1.28	0.80
2600	4.41	35.01	0.65	2.49	1.28	0.80
2650	4.25	34.84	0.65	2.49	1.28	0.80
2700	4.11	34.86	0.66	2.50	1.33	0.80
2750	3.99	34.93	0.65	2.50	1.34	0.80
2800	3.84	34.73	0.65	2.49	1.33	0.80
2850	3.71	34.52	0.65	2.49	1.34	0.79
2900	3.58	34.46	0.65	2.50	1.33	0.80
2950	3.45	34.48	0.64	2.49	1.34	0.80
3000	3.32	34.42	0.66	2.48	1.35	0.80
3050	3.19	34.48	0.64	2.50	1.38	0.80
3100	3.06	34.38	0.65	2.49	1.40	0.80
3150	2.96	34.12	0.64	2.50	1.36	0.80
3200	2.82	34.07	0.65	2.50	1.40	0.80
3250	2.69	34.13	0.66	2.51	1.44	0.80
3300	2.58	34.03	0.65	2.51	1.44	0.80
3350	2.45	33.98	0.67	2.50	1.49	0.80
3400	2.33	33.91	0.66	2.52	1.47	0.80
3450	2.22	33.80	0.66	2.51	1.48	0.80
3500	2.08	33.82	0.68	2.52	1.54	0.80
3550	1.96	33.66	0.69	2.53	1.54	0.80
3600	1.86	33.61	0.68	2.52	1.55	0.80
3650	1.72	33.82	0.71	2.53	1.65	0.80
3700	1.62	33.57	0.69	2.54	1.61	0.80
3750	1.49	33.44	0.71	2.55	1.63	0.80
3800	1.39	33.41	0.71	2.55	1.67	0.80
3850	1.27	33.57	0.72	2.55	1.71	0.81
3900	1.14	33.34	0.73	2.56	1.72	0.81
3950	1.03	33.40	0.74	2.57	1.77	0.81
4000	0.91	33.26	0.75	2.56	1.81	0.80

Note: Test data of Die packaged in industry standard 8-lead 2x2mm MCLP pack.



Typical Performance Data

Definitions:

Input Return Loss = -S11 (dB)

Gain(Power Gain) = S21 (dB)

Reverse Isolation = -S12 (dB)

Output Return Loss = -S22 (dB)

TEST CONDITIONS: Vd = 4.50V, Id = 227mA @ Temperature = -45°C

FREQ (MHz)	Gain (dB)	Isolation (dB)	Input Return Loss (dB)	Output Return Loss (dB)	Stability	
					K	Measure
400	20.43	37.02	0.49	2.41	0.21	0.79
450	19.42	36.84	0.50	2.41	0.25	0.78
500	18.49	36.91	0.52	2.41	0.26	0.79
550	17.67	36.98	0.53	2.41	0.30	0.79
600	16.92	36.95	0.53	2.42	0.32	0.79
650	16.21	36.96	0.55	2.42	0.33	0.80
700	15.57	37.01	0.57	2.43	0.40	0.79
750	14.97	36.75	0.56	2.45	0.41	0.80
800	14.41	36.66	0.58	2.46	0.45	0.79
850	13.90	36.84	0.57	2.44	0.48	0.79
900	13.39	36.69	0.58	2.47	0.49	0.80
950	12.93	36.64	0.58	2.48	0.52	0.80
1000	12.48	36.46	0.60	2.47	0.56	0.80
1050	12.06	36.63	0.61	2.48	0.60	0.80
1100	11.65	36.70	0.62	2.49	0.62	0.80
1150	11.27	36.48	0.62	2.50	0.66	0.80
1200	10.90	36.47	0.63	2.51	0.68	0.81
1250	10.55	36.51	0.63	2.51	0.70	0.81
1300	10.22	36.42	0.64	2.52	0.75	0.81
1350	9.88	36.19	0.65	2.53	0.78	0.81
1400	9.58	36.59	0.64	2.54	0.83	0.81
1450	9.28	36.25	0.65	2.55	0.84	0.81
1500	9.00	36.29	0.66	2.55	0.86	0.81
1550	8.73	36.19	0.66	2.54	0.91	0.81
1600	8.47	36.18	0.66	2.55	0.92	0.81
1650	8.21	35.83	0.67	2.56	0.93	0.81
1700	7.97	36.13	0.67	2.56	0.96	0.82
1750	7.73	35.88	0.66	2.56	0.96	0.82
1800	7.50	35.96	0.67	2.56	1.00	0.82
1850	7.28	35.82	0.67	2.57	1.02	0.82
1900	7.06	35.95	0.66	2.57	1.04	0.82
1950	6.86	35.85	0.67	2.58	1.06	0.82
2000	6.66	35.61	0.67	2.57	1.06	0.82
2050	6.47	35.59	0.66	2.56	1.09	0.82
2100	6.28	35.60	0.66	2.59	1.11	0.82
2150	6.09	35.55	0.66	2.56	1.12	0.82
2200	5.93	35.45	0.66	2.58	1.14	0.82
2250	5.75	35.26	0.66	2.59	1.15	0.82
2300	5.58	35.37	0.65	2.59	1.17	0.82
2350	5.41	35.23	0.66	2.58	1.17	0.82
2400	5.26	34.84	0.65	2.58	1.15	0.82
2450	5.10	35.10	0.65	2.59	1.19	0.82
2500	4.95	34.88	0.64	2.58	1.19	0.82
2550	4.80	35.01	0.64	2.57	1.22	0.82
2600	4.66	34.82	0.63	2.58	1.20	0.82
2650	4.52	34.74	0.63	2.57	1.21	0.82
2700	4.37	34.65	0.64	2.58	1.23	0.82
2750	4.24	34.60	0.63	2.58	1.25	0.82
2800	4.10	34.70	0.63	2.57	1.27	0.82
2850	3.97	34.46	0.64	2.57	1.26	0.82
2900	3.84	34.55	0.63	2.57	1.28	0.82
2950	3.71	34.35	0.62	2.57	1.26	0.82
3000	3.58	34.24	0.63	2.56	1.28	0.82
3050	3.45	34.24	0.62	2.58	1.28	0.82
3100	3.32	34.16	0.63	2.58	1.30	0.82
3150	3.21	34.12	0.61	2.58	1.30	0.82
3200	3.07	34.05	0.62	2.58	1.33	0.82
3250	2.95	34.00	0.64	2.59	1.36	0.82
3300	2.84	33.93	0.63	2.59	1.35	0.82
3350	2.70	33.90	0.64	2.58	1.39	0.82
3400	2.59	33.82	0.64	2.59	1.39	0.82
3450	2.48	33.74	0.63	2.58	1.39	0.82
3500	2.34	33.77	0.65	2.59	1.43	0.82
3550	2.23	33.65	0.66	2.61	1.46	0.82
3600	2.11	33.46	0.66	2.59	1.45	0.82
3650	1.98	33.58	0.67	2.61	1.52	0.82
3700	1.88	33.53	0.67	2.62	1.52	0.83
3750	1.75	33.41	0.68	2.61	1.54	0.82
3800	1.64	33.56	0.69	2.62	1.60	0.82
3850	1.53	33.30	0.68	2.63	1.58	0.83
3900	1.40	33.36	0.69	2.64	1.61	0.83
3950	1.29	33.14	0.70	2.63	1.63	0.83
4000	1.17	33.19	0.72	2.64	1.67	0.83

Note: Test data of Die packaged in industry standard 8-lead 2x2mm MCL P pack



Typical Performance Data

Definitions:

- Input Return Loss = -S11 (dB)
- Gain(Power Gain) = S21 (dB)
- Reverse Isolation = -S12 (dB)
- Output Return Loss = -S22 (dB)

TEST CONDITIONS: Vd = 4.50V, Id = 309mA @ Temperature = +85°C

FREQ (MHz)	Gain (dB)	Isolation (dB)	Input Return Loss (dB)	Output Return Loss (dB)	Stability	
					K	Measure
400	19.97	37.02	0.49	2.41	0.23	0.75
450	18.95	36.84	0.50	2.41	0.26	0.75
500	18.02	37.51	0.54	2.26	0.31	0.75
550	17.19	37.20	0.55	2.27	0.35	0.74
600	16.44	37.56	0.55	2.27	0.37	0.75
650	15.74	37.14	0.57	2.27	0.39	0.75
700	15.09	37.20	0.58	2.29	0.45	0.75
750	14.49	37.33	0.58	2.31	0.48	0.76
800	13.93	37.26	0.60	2.32	0.49	0.76
850	13.42	37.28	0.60	2.30	0.53	0.76
900	12.92	37.18	0.60	2.33	0.57	0.76
950	12.45	37.03	0.61	2.34	0.58	0.77
1000	12.01	36.97	0.62	2.33	0.63	0.76
1050	11.59	37.15	0.63	2.34	0.67	0.76
1100	11.18	36.93	0.64	2.35	0.69	0.76
1150	10.81	36.82	0.64	2.37	0.72	0.77
1200	10.43	36.93	0.65	2.38	0.77	0.77
1250	10.09	36.87	0.65	2.38	0.80	0.77
1300	9.76	36.82	0.66	2.38	0.84	0.77
1350	9.42	36.90	0.67	2.40	0.88	0.78
1400	9.13	36.65	0.66	2.40	0.90	0.77
1450	8.83	36.55	0.67	2.41	0.92	0.78
1500	8.54	36.45	0.68	2.42	0.96	0.78
1550	8.27	36.40	0.68	2.42	0.98	0.78
1600	8.02	36.60	0.68	2.42	1.01	0.78
1650	7.76	36.56	0.69	2.43	1.06	0.78
1700	7.52	36.38	0.69	2.43	1.08	0.78
1750	7.28	36.43	0.69	2.44	1.11	0.78
1800	7.06	36.21	0.69	2.44	1.12	0.78
1850	6.84	36.14	0.69	2.45	1.14	0.78
1900	6.62	36.23	0.69	2.44	1.16	0.78
1950	6.42	35.76	0.70	2.46	1.14	0.79
2000	6.22	35.70	0.69	2.44	1.17	0.78
2050	6.03	35.97	0.69	2.46	1.23	0.79
2100	5.84	35.83	0.69	2.47	1.24	0.79
2150	5.65	35.72	0.69	2.45	1.24	0.79
2200	5.49	35.49	0.69	2.46	1.24	0.79
2250	5.31	35.75	0.69	2.47	1.31	0.79
2300	5.14	35.53	0.68	2.47	1.27	0.79
2350	4.97	35.39	0.69	2.47	1.31	0.79
2400	4.82	35.36	0.69	2.47	1.30	0.79
2450	4.66	35.17	0.68	2.48	1.33	0.79
2500	4.52	35.14	0.68	2.48	1.32	0.79
2550	4.36	35.00	0.68	2.47	1.34	0.79
2600	4.23	34.91	0.67	2.47	1.31	0.79
2650	4.07	34.99	0.67	2.47	1.36	0.79
2700	3.92	34.85	0.68	2.48	1.38	0.79
2750	3.80	35.01	0.67	2.48	1.39	0.79
2800	3.65	34.74	0.68	2.47	1.41	0.79
2850	3.52	34.57	0.68	2.47	1.41	0.79
2900	3.39	34.75	0.68	2.48	1.45	0.79
2950	3.26	34.35	0.67	2.47	1.40	0.79
3000	3.13	34.41	0.69	2.47	1.44	0.79
3050	3.00	34.23	0.67	2.49	1.43	0.79
3100	2.87	34.30	0.68	2.49	1.48	0.79
3150	2.76	34.37	0.67	2.48	1.47	0.79
3200	2.62	34.11	0.68	2.49	1.48	0.79
3250	2.49	34.06	0.69	2.50	1.51	0.79
3300	2.38	34.08	0.69	2.50	1.53	0.80
3350	2.25	34.12	0.71	2.49	1.58	0.79
3400	2.13	33.86	0.70	2.50	1.57	0.80
3450	2.02	33.83	0.70	2.50	1.58	0.79
3500	1.88	33.87	0.72	2.50	1.64	0.79
3550	1.76	33.62	0.73	2.52	1.65	0.80
3600	1.65	33.56	0.73	2.51	1.65	0.79
3650	1.51	33.86	0.75	2.53	1.76	0.80
3700	1.41	33.61	0.74	2.54	1.73	0.80
3750	1.28	33.55	0.76	2.53	1.78	0.80
3800	1.17	33.48	0.76	2.55	1.80	0.80
3850	1.06	33.23	0.76	2.55	1.79	0.80
3900	0.93	33.44	0.77	2.56	1.86	0.80
3950	0.81	33.39	0.78	2.57	1.90	0.80
4000	0.69	33.45	0.80	2.57	1.97	0.80

Note: Test data of Die packaged in industry standard 8-lead 2x2mm MCL P pack



Typical Performance Data

Definitions:

Input Return Loss = -S11 (dB)
 Gain(Power Gain) = S21 (dB)
 Reverse Isolation = -S12 (dB)
 Output Return Loss = -S22 (dB)

TEST CONDITIONS: Vd = 4.50V, Id = 281mA @ Temperature = +25°C

FREQ	Gain	Isolation	Input Return Loss	Output Return Loss	Stability		IP-3 Output	1dB Comp. Output	Noise Figure
					K	Measure			
(MHz)	(dB)	(dB)	(dB)	(dB)			(dBm)	(dBm)	(dB)
400	-44.12	84.21	0.08	0.09	481.91	0.04	-	-	-
450	-40.62	72.55	0.09	0.10	110.82	0.05	-	-	-
500	-37.67	70.71	0.10	0.11	69.97	0.05	-6.66	-22.23	32.89
550	-35.20	69.75	0.11	0.11	55.55	0.05	-6.82	-19.75	30.95
600	-32.58	73.58	0.10	0.11	63.04	0.05	3.28	-17.95	30.96
650	-30.16	74.62	0.08	0.11	43.32	0.05	2.33	-14.46	21.88
700	-28.16	70.71	0.12	0.16	42.43	0.07	5.73	-12.60	21.49
750	-25.80	73.08	0.13	0.17	47.36	0.07	9.86	-10.81	20.33
800	-23.62	72.22	0.13	0.19	38.61	0.08	15.74	-8.09	15.64
850	-21.52	70.39	0.14	0.21	29.31	0.09	15.84	-5.89	12.94
900	-19.44	72.17	0.15	0.24	34.66	0.10	19.37	-4.29	12.65
950	-17.39	70.16	0.16	0.27	24.87	0.12	19.53	-3.92	11.87
1000	-15.34	60.39	0.17	0.30	7.90	0.13	23.07	-2.94	8.36
1050	-13.32	61.69	0.18	0.36	9.28	0.16	27.97	0.58	7.79
1100	-11.29	59.78	0.21	0.44	7.91	0.19	27.46	3.72	7.78
1150	-9.23	56.36	0.24	0.53	5.54	0.22	30.72	4.27	6.20
1200	-7.17	54.32	0.27	0.66	4.54	0.27	32.56	4.46	5.89
1250	-5.08	52.22	0.33	0.82	4.06	0.33	34.74	6.94	5.75
1300	-2.94	50.15	0.38	1.04	3.64	0.41	35.48	9.00	5.37
1350	-0.78	47.35	0.47	1.34	2.85	0.51	34.76	11.80	5.48
1400	1.39	44.43	0.59	1.75	2.38	0.63	35.52	14.49	5.02
1450	3.56	41.57	0.76	2.30	2.03	0.77	34.62	15.34	4.18
1500	5.73	39.20	0.99	3.04	1.83	0.93	34.40	16.43	3.63
1550	7.80	37.09	1.32	4.02	1.78	1.09	35.97	18.56	3.13
1600	9.79	34.49	1.75	5.17	1.56	1.21	37.88	22.87	2.78
1650	11.66	32.24	2.34	6.37	1.45	1.27	37.55	24.95	2.37
1700	13.39	30.25	3.18	7.52	1.38	1.25	37.42	26.06	2.06
1750	14.98	28.35	4.43	8.63	1.31	1.16	38.41	27.11	1.96
1800	16.30	26.76	6.33	10.38	1.28	1.05	37.16	28.00	1.63
1850	17.16	25.51	8.29	14.51	1.23	0.99	40.89	28.57	1.56
1900	17.26	25.10	7.47	34.61	1.21	1.02	39.45	29.36	1.29
1950	16.50	25.61	4.90	15.44	1.20	1.10	39.89	29.07	1.27
2000	15.19	26.59	3.07	9.68	1.19	1.14	40.86	27.63	1.24
2050	13.66	27.80	2.02	7.02	1.19	1.14	37.72	27.10	1.31
2100	12.15	29.07	1.43	5.51	1.19	1.10	40.02	26.63	1.24
2150	10.73	30.18	1.08	4.54	1.20	1.04	40.44	26.11	1.62
2200	9.44	31.22	0.86	3.90	1.21	0.99	38.15	25.45	1.36
2250	8.28	32.06	0.71	3.43	1.21	0.94	36.71	24.49	1.38
2300	7.21	33.02	0.62	3.08	1.25	0.89	36.71	24.16	1.56
2350	6.26	33.43	0.54	2.80	1.22	0.84	36.69	22.31	1.64
2400	5.40	34.28	0.49	2.59	1.26	0.81	34.74	20.82	2.44
2450	4.60	34.66	0.45	2.43	1.26	0.78	33.46	19.87	2.61
2500	3.89	35.17	0.42	2.27	1.29	0.74	37.15	18.72	2.34
2550	3.25	35.33	0.39	2.15	1.26	0.72	35.09	17.75	2.28
2600	2.64	35.94	0.37	2.07	1.30	0.70	33.57	16.71	2.64
2650	2.08	36.56	0.34	1.98	1.32	0.68	33.45	16.07	3.19
2700	1.58	36.45	0.34	1.91	1.33	0.66	35.94	15.70	2.99
2750	1.12	36.88	0.33	1.84	1.39	0.65	32.23	15.28	3.02
2800	0.67	36.65	0.32	1.80	1.35	0.63	36.72	15.39	3.48
2850	0.27	37.15	0.32	1.74	1.39	0.62	33.20	15.69	3.66
2900	-0.09	37.11	0.31	1.70	1.39	0.61	34.43	15.35	3.57
2950	-0.44	37.20	0.30	1.67	1.40	0.60	34.10	13.86	3.79
3000	-0.77	37.49	0.30	1.66	1.44	0.60	34.46	13.81	4.27
3050	-1.04	37.42	0.29	1.62	1.42	0.59	34.09	12.99	3.98
3100	-1.31	37.47	0.30	1.61	1.44	0.59	32.87	11.98	4.25
3150	-1.57	37.79	0.30	1.58	1.51	0.58	36.11	12.28	4.05
3200	-1.82	37.32	0.30	1.58	1.49	0.58	34.35	11.14	4.75
3250	-2.02	37.95	0.30	1.55	1.54	0.57	33.64	17.38	4.12
3300	-2.22	37.50	0.31	1.54	1.54	0.56	33.75	17.65	5.43
3350	-2.40	37.45	0.31	1.56	1.57	0.57	33.46	17.11	4.74
3400	-2.59	37.50	0.32	1.55	1.64	0.57	33.52	17.28	5.27
3450	-2.71	37.61	0.31	1.54	1.61	0.57	33.97	17.05	5.12
3500	-2.87	37.40	0.32	1.53	1.63	0.56	32.31	17.13	5.07
3550	-3.00	37.34	0.33	1.55	1.68	0.57	33.55	16.61	4.69
3600	-3.13	37.17	0.33	1.55	1.67	0.57	33.74	16.97	5.88
3650	-3.22	37.30	0.34	1.55	1.70	0.57	33.85	16.48	5.83
3700	-3.32	37.09	0.35	1.55	1.72	0.57	32.27	15.85	5.44
3750	-3.39	37.12	0.35	1.56	1.75	0.57	33.99	16.64	5.09
3800	-3.46	37.16	0.35	1.57	1.76	0.58	34.07	15.77	6.13
3850	-3.53	36.29	0.38	1.58	1.76	0.57	31.88	15.60	5.12
3900	-3.58	36.70	0.37	1.59	1.81	0.58	33.94	16.53	5.33
3950	-3.61	36.44	0.38	1.59	1.79	0.58	31.98	15.84	5.89
4000	-3.64	36.39	0.39	1.62	1.83	0.59	33.61	16.32	5.25

Note: Test data of Die packaged in industry standard 8-lead 2x2mm MCLP package



Typical Performance Data

Definitions:

Input Return Loss = -S11 (dB)
 Gain(Power Gain) = S21 (dB)
 Reverse Isolation = -S12 (dB)
 Output Return Loss = -S22 (dB)

TEST CONDITIONS: Vd = 4.50V, Id = 182mA @ Temperature = -45°C

FREQ	Gain	Isolation	Input Return Loss	Output Return Loss	Stability		IP-3 Output	1dB Comp. Output	Noise Figure
					K	Measure			
(MHz)	(dB)	(dB)	(dB)	(dB)			(dBm)	(dBm)	(dB)
400	-43.29	84.21	0.08	0.09	75.94	0.04	-	-	-
450	-40.80	72.55	0.09	0.10	68.09	0.05	-	-	-
500	-37.54	73.45	0.09	0.11	91.30	0.05	-8.56	-22.57	30.85
550	-34.82	83.03	0.11	0.12	257.32	0.05	-3.81	-19.09	28.87
600	-32.33	65.81	0.10	0.12	26.12	0.05	-2.49	-19.09	28.89
650	-29.98	79.24	0.10	0.13	99.59	0.06	2.45	-14.10	20.53
700	-27.71	66.59	0.12	0.16	25.30	0.07	4.92	-11.95	20.23
750	-25.43	68.40	0.13	0.16	26.52	0.07	7.80	-11.10	17.95
800	-23.27	62.34	0.12	0.16	9.84	0.07	13.00	-8.46	17.50
850	-21.17	68.25	0.14	0.21	21.16	0.09	13.90	-5.80	14.09
900	-19.11	72.43	0.14	0.22	30.44	0.10	24.54	-4.79	13.51
950	-17.06	68.83	0.15	0.25	18.36	0.11	20.82	-4.25	12.80
1000	-15.09	66.93	0.18	0.31	16.44	0.13	24.37	-4.42	11.30
1050	-13.05	62.78	0.18	0.35	9.62	0.15	24.71	0.81	8.19
1100	-11.01	58.53	0.20	0.42	5.93	0.18	27.15	3.40	8.00
1150	-8.99	55.45	0.24	0.50	4.58	0.21	28.82	4.55	7.21
1200	-6.92	53.85	0.26	0.63	3.80	0.26	31.09	5.11	5.57
1250	-4.85	50.82	0.30	0.79	2.89	0.32	34.16	6.82	5.37
1300	-2.73	48.35	0.35	0.99	2.25	0.39	34.46	8.90	4.64
1350	-0.61	46.43	0.45	1.28	2.21	0.49	33.29	11.84	4.26
1400	1.52	44.35	0.56	1.69	2.06	0.62	32.91	13.39	3.45
1450	3.64	41.79	0.73	2.22	1.87	0.76	31.34	15.37	3.19
1500	5.75	39.38	0.93	2.92	1.66	0.91	31.69	16.65	2.87
1550	7.80	37.03	1.21	3.80	1.50	1.06	30.81	17.85	2.40
1600	9.76	34.44	1.61	4.80	1.35	1.18	33.24	20.91	2.00
1650	11.63	32.13	2.12	5.82	1.23	1.24	32.28	21.74	1.77
1700	13.37	30.23	2.85	6.75	1.20	1.23	33.53	23.42	1.48
1750	14.99	28.23	3.93	7.65	1.15	1.15	34.60	25.00	1.36
1800	16.43	26.48	5.51	9.04	1.11	1.05	34.47	28.28	1.31
1850	17.47	25.15	7.31	12.25	1.09	0.98	36.31	29.70	1.14
1900	17.73	24.61	6.99	22.58	1.08	1.01	36.08	30.22	0.85
1950	17.08	24.88	4.73	17.87	1.06	1.10	40.59	29.53	0.78
2000	15.78	25.92	2.93	10.53	1.06	1.16	40.85	25.83	0.80
2050	14.23	27.25	1.90	7.48	1.07	1.16	40.06	27.25	0.82
2100	12.66	28.47	1.33	5.79	1.07	1.13	38.96	26.39	0.77
2150	11.22	29.66	1.01	4.75	1.09	1.07	37.20	25.50	1.00
2200	9.90	30.77	0.81	4.06	1.11	1.01	36.50	24.70	0.94
2250	8.69	31.57	0.67	3.57	1.11	0.96	38.51	23.42	0.98
2300	7.62	32.50	0.59	3.21	1.14	0.91	36.08	21.84	1.04
2350	6.67	33.04	0.52	2.93	1.15	0.87	36.20	22.09	1.26
2400	5.77	33.70	0.48	2.71	1.17	0.83	33.64	21.59	1.50
2450	5.00	34.26	0.43	2.52	1.16	0.80	33.93	19.60	1.91
2500	4.27	35.02	0.40	2.37	1.23	0.77	36.67	18.61	1.75
2550	3.60	35.24	0.40	2.23	1.25	0.74	34.92	17.50	1.69
2600	3.01	35.80	0.37	2.13	1.27	0.72	33.69	16.50	2.10
2650	2.44	35.96	0.35	2.05	1.27	0.70	35.49	16.27	2.37
2700	1.94	36.18	0.35	1.98	1.31	0.68	32.23	15.76	2.42
2750	1.48	36.55	0.34	1.91	1.33	0.66	34.08	16.65	2.71
2800	1.03	36.86	0.33	1.86	1.33	0.65	33.31	16.47	2.56
2850	0.63	36.84	0.32	1.81	1.34	0.64	33.98	16.39	3.15
2900	0.27	36.95	0.32	1.76	1.34	0.63	34.15	15.53	3.04
2950	-0.08	37.37	0.31	1.73	1.40	0.62	34.58	13.76	3.22
3000	-0.39	37.08	0.32	1.69	1.38	0.61	35.15	13.96	3.59
3050	-0.68	37.41	0.31	1.66	1.42	0.60	33.36	13.82	2.88
3100	-0.95	37.56	0.30	1.64	1.43	0.60	35.15	13.54	3.08
3150	-1.20	37.70	0.30	1.63	1.44	0.59	34.75	12.47	2.85
3200	-1.44	37.67	0.30	1.62	1.49	0.59	32.28	11.53	2.80
3250	-1.65	37.27	0.30	1.60	1.46	0.58	32.73	18.09	3.60
3300	-1.85	37.90	0.31	1.59	1.53	0.58	32.85	17.95	2.97
3350	-2.03	37.38	0.31	1.57	1.47	0.58	34.33	17.44	4.13
3400	-2.19	37.24	0.31	1.57	1.50	0.58	32.96	17.28	4.02
3450	-2.35	37.38	0.32	1.56	1.54	0.57	33.11	16.04	4.12
3500	-2.48	37.28	0.32	1.56	1.51	0.57	33.86	16.45	3.37
3550	-2.62	37.31	0.32	1.57	1.58	0.58	33.70	16.61	3.73
3600	-2.73	37.18	0.33	1.58	1.56	0.58	34.29	16.06	3.86
3650	-2.86	36.79	0.34	1.57	1.58	0.58	33.39	16.33	4.56
3700	-2.94	37.36	0.34	1.57	1.66	0.57	33.44	16.25	3.71
3750	-3.03	36.84	0.37	1.58	1.69	0.57	32.92	16.01	4.24
3800	-3.10	36.67	0.35	1.59	1.65	0.58	34.16	15.69	4.76
3850	-3.16	36.79	0.37	1.59	1.69	0.58	32.19	15.57	4.85
3900	-3.22	36.50	0.37	1.61	1.64	0.59	32.55	16.15	4.21
3950	-3.28	36.43	0.37	1.61	1.69	0.58	34.61	16.51	4.94
4000	-3.33	36.08	0.39	1.64	1.71	0.59	32.21	16.03	3.87

Note: Test data of Die packaged in industry standard 8-lead 2x2mm MCLP package



Typical Performance Data

Definitions:

Input Return Loss = -S11 (dB)
 Gain(Power Gain) = S21 (dB)
 Reverse Isolation = -S12 (dB)
 Output Return Loss = -S22 (dB)

TEST CONDITIONS: Vd = 4.50V, Id = 364mA @ Temperature = +85°C

FREQ	Gain	Isolation	Input Return Loss	Output Return Loss	Stability		IP-3 Output	1dB Comp. Output	Noise Figure
					K	Measure			
(MHz)	(dB)	(dB)	(dB)	(dB)			(dBm)	(dBm)	(dB)
400	-43.41	84.21	0.08	0.09	172.22	0.06	-	-	-
450	-40.86	72.55	0.09	0.10	170.18	0.07	-	-	-
500	-37.66	75.86	0.12	0.16	240.94	0.07	-10.29	-22.91	32.56
550	-35.17	78.84	0.14	0.18	312.75	0.08	-2.66	-19.51	29.87
600	-32.65	69.97	0.14	0.18	87.75	0.08	4.71	-19.51	30.40
650	-30.35	77.65	0.14	0.19	170.88	0.08	-1.21	-14.52	22.22
700	-28.08	69.00	0.16	0.22	61.50	0.10	9.11	-12.36	21.72
750	-25.82	64.94	0.17	0.23	33.69	0.10	8.60	-11.51	18.58
800	-23.70	67.16	0.16	0.23	33.79	0.10	10.38	-8.85	18.45
850	-21.56	68.03	0.18	0.28	37.59	0.12	14.16	-6.17	14.97
900	-19.51	66.06	0.19	0.30	26.44	0.13	19.60	-5.16	14.66
950	-17.44	76.95	0.20	0.32	84.24	0.14	22.42	-4.61	13.57
1000	-15.43	65.40	0.22	0.39	22.88	0.17	25.07	-4.77	13.27
1050	-13.38	64.45	0.23	0.44	19.57	0.19	30.13	0.48	11.71
1100	-11.36	61.93	0.25	0.52	13.99	0.22	29.47	3.11	8.46
1150	-9.30	56.76	0.29	0.60	8.00	0.25	29.68	4.27	8.36
1200	-7.22	53.77	0.32	0.73	5.69	0.30	31.81	4.84	8.14
1250	-5.12	51.66	0.36	0.90	4.74	0.36	37.31	6.58	7.83
1300	-2.98	49.69	0.42	1.11	3.95	0.43	38.70	8.71	6.99
1350	-0.83	47.08	0.52	1.42	3.36	0.53	35.58	11.72	6.36
1400	1.33	44.50	0.65	1.84	2.85	0.65	37.23	13.34	5.47
1450	3.50	41.70	0.83	2.41	2.43	0.79	36.02	15.45	4.97
1500	5.65	39.50	1.06	3.16	2.19	0.94	36.29	16.79	4.40
1550	7.73	36.99	1.38	4.13	1.91	1.10	36.74	18.14	3.81
1600	9.72	34.65	1.84	5.28	1.75	1.21	37.00	21.54	3.34
1650	11.59	32.40	2.47	6.48	1.59	1.26	37.84	24.59	2.86
1700	13.31	30.56	3.39	7.62	1.54	1.23	37.41	26.22	2.51
1750	14.85	28.61	4.79	8.78	1.45	1.14	39.30	26.91	2.48
1800	16.12	26.96	6.89	10.65	1.38	1.03	43.08	27.85	2.08
1850	16.90	25.82	8.95	15.13	1.33	0.98	39.87	29.15	1.70
1900	16.90	25.56	7.72	34.68	1.31	1.03	39.82	29.43	1.63
1950	16.08	26.15	4.96	14.97	1.31	1.12	40.87	28.75	1.59
2000	14.75	27.03	3.13	9.64	1.29	1.16	37.92	27.16	1.61
2050	13.25	28.22	2.10	7.05	1.29	1.15	39.77	26.99	1.67
2100	11.75	29.51	1.50	5.56	1.30	1.11	40.26	26.35	1.70
2150	10.36	30.40	1.15	4.62	1.29	1.05	37.43	25.82	2.00
2200	9.09	31.54	0.94	3.98	1.33	1.00	39.64	24.54	2.00
2250	7.91	32.47	0.79	3.52	1.36	0.95	36.80	23.07	2.14
2300	6.88	33.04	0.69	3.17	1.37	0.90	37.26	21.50	2.25
2350	5.94	33.71	0.61	2.91	1.38	0.86	36.44	21.81	2.52
2400	5.07	34.43	0.57	2.69	1.43	0.83	35.33	21.30	2.90
2450	4.31	34.90	0.52	2.52	1.44	0.79	34.10	19.22	3.19
2500	3.60	35.52	0.49	2.37	1.48	0.77	37.56	18.15	2.84
2550	2.93	36.19	0.47	2.26	1.55	0.74	35.99	17.02	3.77
2600	2.36	36.30	0.45	2.16	1.54	0.72	34.33	15.98	3.75
2650	1.80	36.70	0.43	2.07	1.58	0.70	35.64	15.77	4.23
2700	1.30	36.69	0.42	1.99	1.57	0.68	32.51	15.25	4.27
2750	0.84	36.84	0.41	1.94	1.61	0.67	35.27	16.18	4.51
2800	0.40	37.21	0.40	1.88	1.65	0.65	33.92	16.00	4.52
2850	0.01	37.31	0.39	1.84	1.65	0.65	36.57	15.92	4.91
2900	-0.35	37.30	0.39	1.80	1.70	0.63	34.49	15.03	4.94
2950	-0.69	37.37	0.38	1.77	1.71	0.63	35.31	13.22	5.08
3000	-1.00	37.60	0.38	1.74	1.75	0.62	35.53	13.42	5.54
3050	-1.29	37.57	0.38	1.71	1.75	0.61	34.16	13.27	5.11
3100	-1.55	37.59	0.36	1.69	1.76	0.61	36.54	12.99	5.44
3150	-1.81	37.94	0.37	1.69	1.83	0.61	35.26	11.91	5.24
3200	-2.03	37.66	0.38	1.67	1.84	0.60	32.58	10.95	5.15
3250	-2.24	37.80	0.37	1.66	1.86	0.60	35.11	17.75	5.74
3300	-2.44	37.56	0.37	1.64	1.86	0.59	33.84	17.60	5.53
3350	-2.61	37.77	0.38	1.64	1.91	0.59	36.66	17.07	6.27
3400	-2.78	37.53	0.38	1.64	1.93	0.59	33.59	16.90	6.41
3450	-2.93	37.65	0.40	1.63	1.98	0.59	33.08	15.62	6.39
3500	-3.07	37.27	0.39	1.63	1.96	0.59	35.25	16.04	5.77
3550	-3.19	37.60	0.40	1.65	2.04	0.59	33.92	16.21	6.09
3600	-3.30	37.40	0.40	1.66	2.05	0.60	34.70	15.65	6.11
3650	-3.42	37.25	0.42	1.66	2.07	0.60	33.70	15.93	6.76
3700	-3.49	37.02	0.42	1.66	2.08	0.59	35.55	15.86	6.40
3750	-3.58	36.58	0.44	1.68	2.08	0.60	32.27	15.61	6.61
3800	-3.64	36.87	0.43	1.68	2.11	0.60	35.39	15.28	7.31
3850	-3.69	36.65	0.45	1.69	2.13	0.60	33.86	15.17	7.18
3900	-3.74	36.45	0.45	1.70	2.13	0.61	32.55	15.77	6.63
3950	-3.78	36.54	0.46	1.72	2.19	0.61	36.71	16.14	7.31
4000	-3.83	36.09	0.48	1.75	2.21	0.62	33.61	15.66	6.75

Note: Test data of Die packaged in industry standard 8-lead 2x2mm MCLP package



Typical Performance Curves

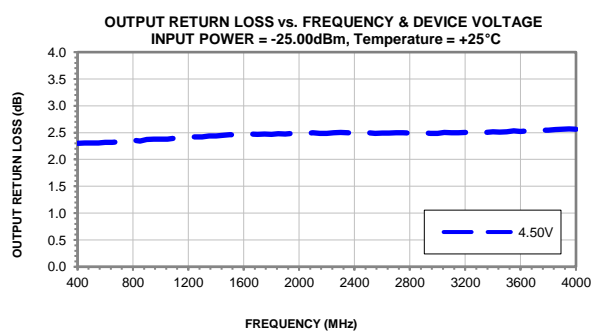
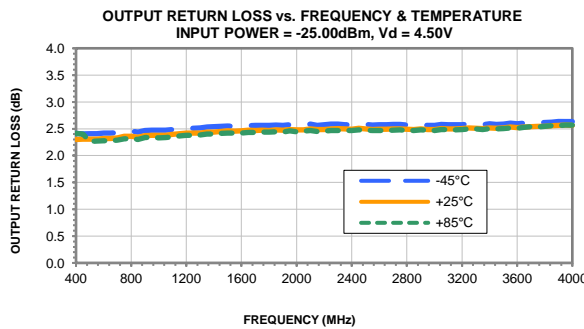
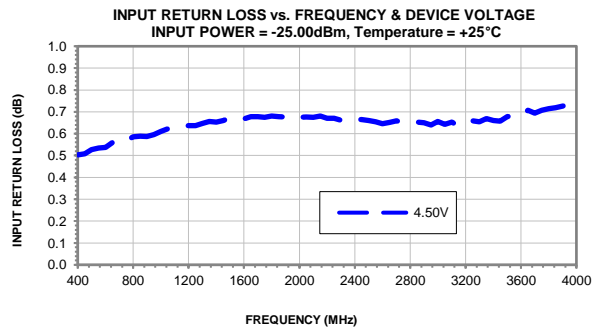
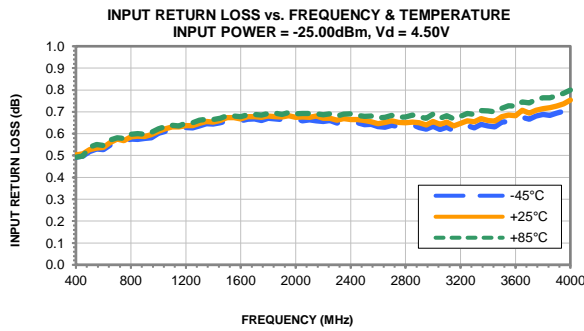
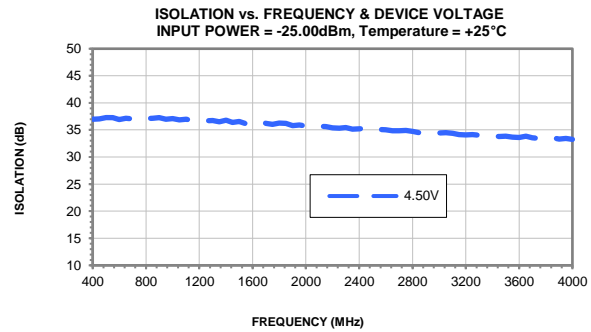
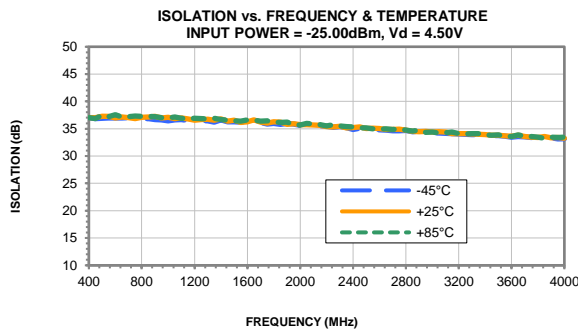
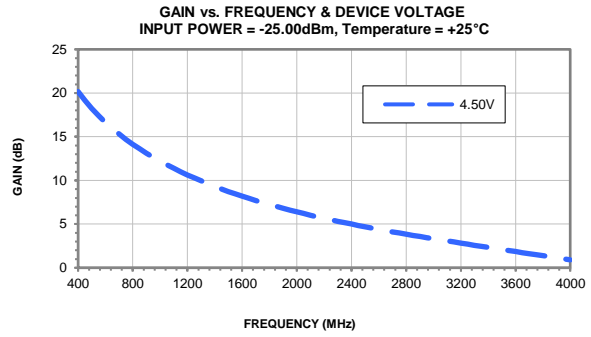
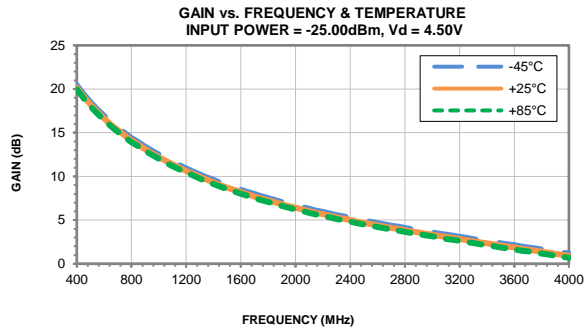

Note: Test data of Die packaged in industry standard 8-lead 2x2mm MCLP package

Typical Performance Curves

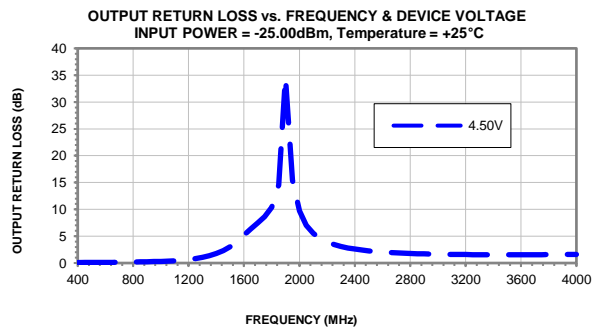
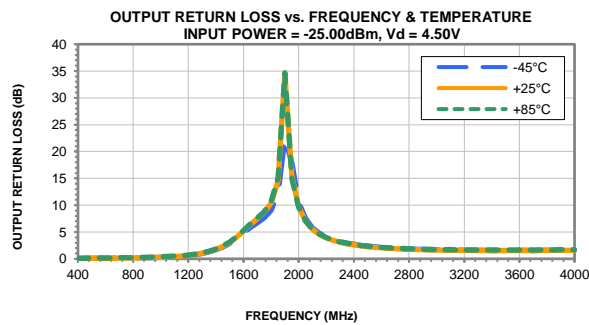
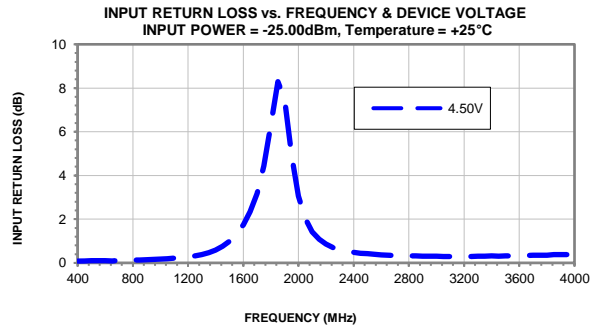
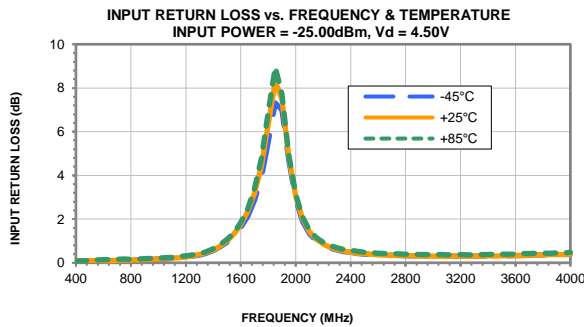
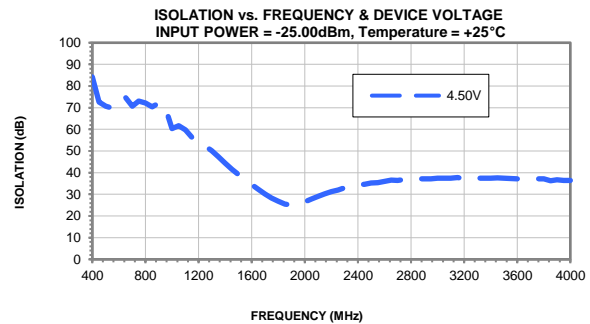
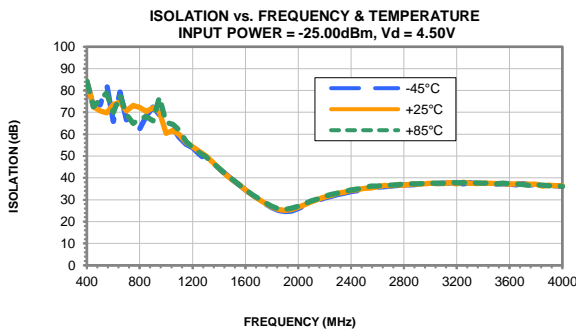
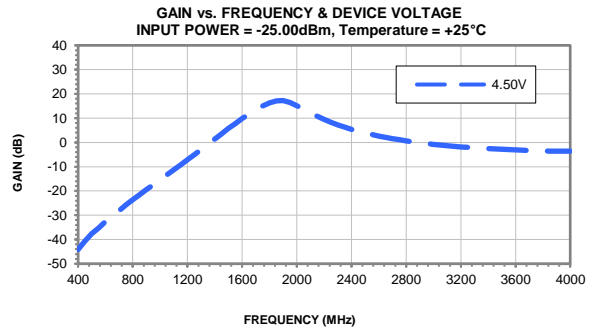
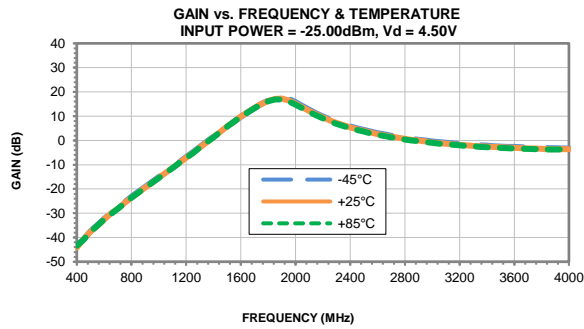

Note: Test data of Die packaged in industry standard 8-lead 2x2mm MCLP package

Typical Performance Curves

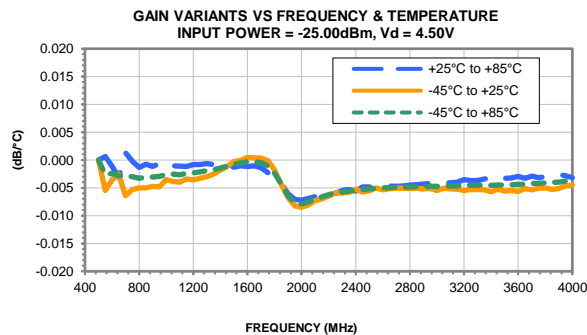
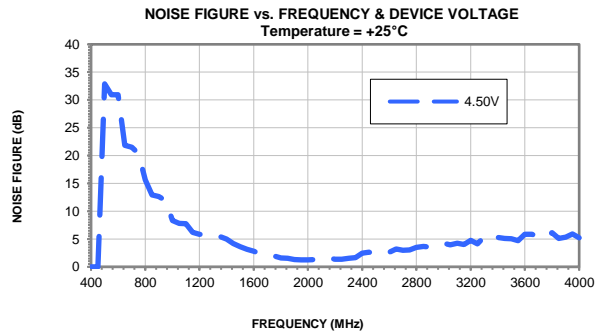
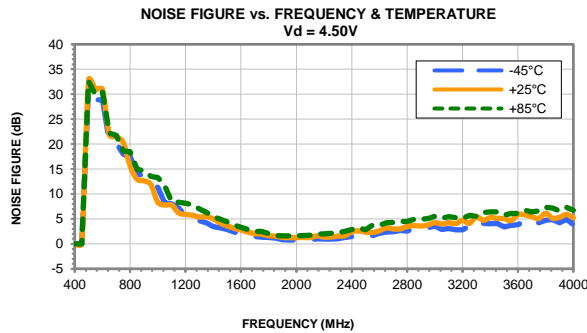
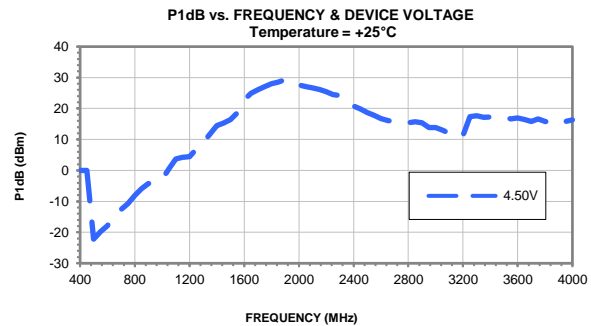
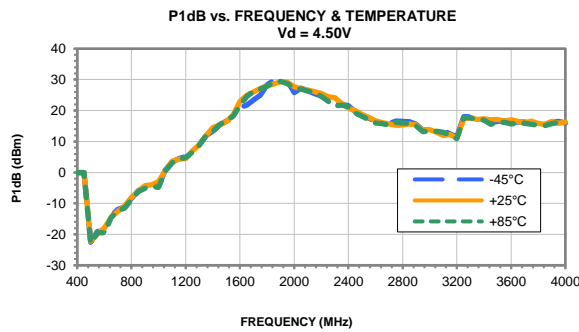
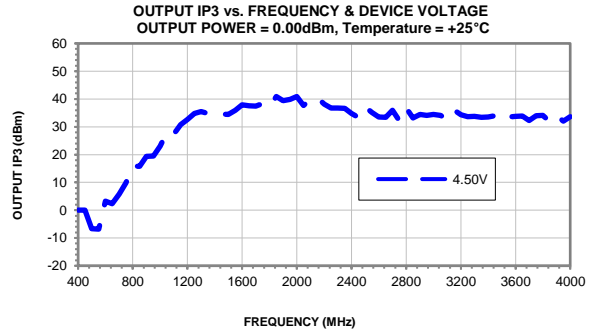
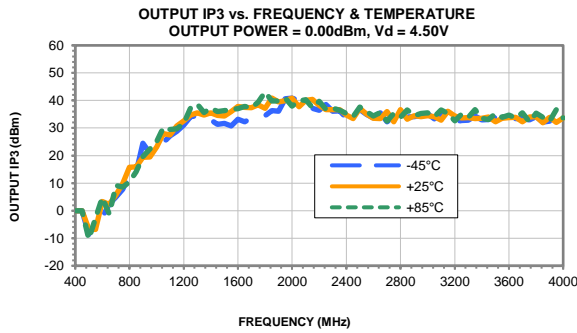

Note: Test data of Die packaged in industry standard 8-lead 2x2mm MCLP package

All Mini-Circuits products are manufactured under exacting quality assurance and control standards, and are capable of meeting published specifications after being subjected to any or all of the following physical and environmental test.

Specification	Test/Inspection Condition	Reference/Spec
Operating Temperature	-40° to 85° C or -40° to 105° C or -55° to 105° C or -45° to 105° C Ambient Environment	Refer to Individual Model Data Sheet
Storage Environment (Die)	-65° to 150°C	Individual Model Data Sheet
Storage Environment(Packaging)	-40° to 70°C and 40 to 60% humidity (In Factory Shipped Package)	