

ELECTRICAL SCHEME-GENERAL

(TB for KSN)

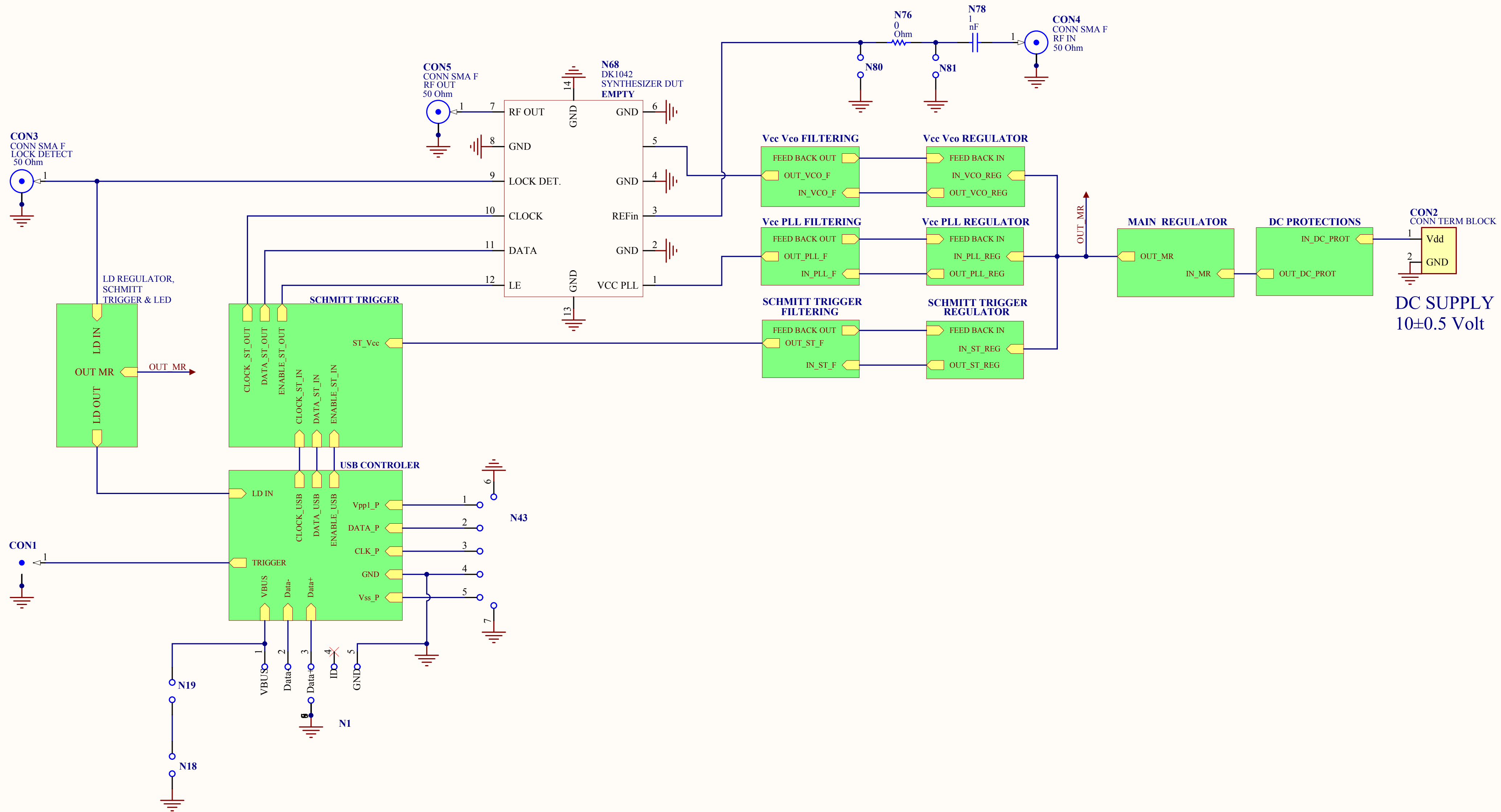

DC PROTECTIONS

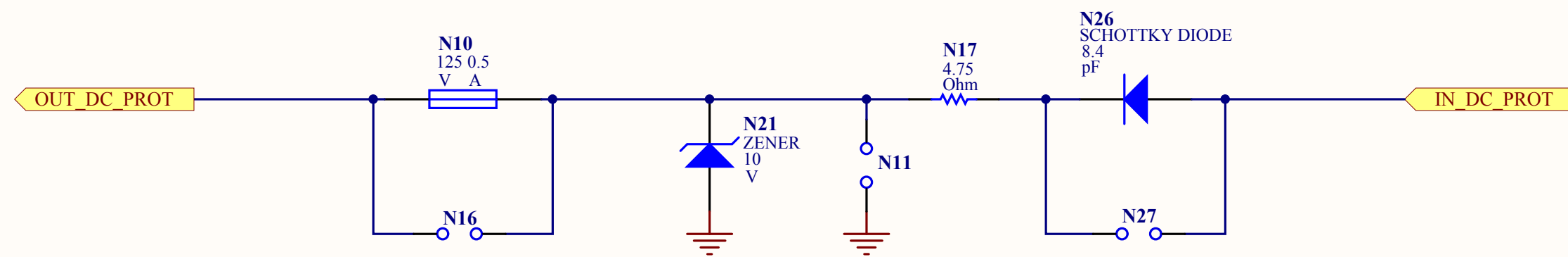

MAIN REGULATOR

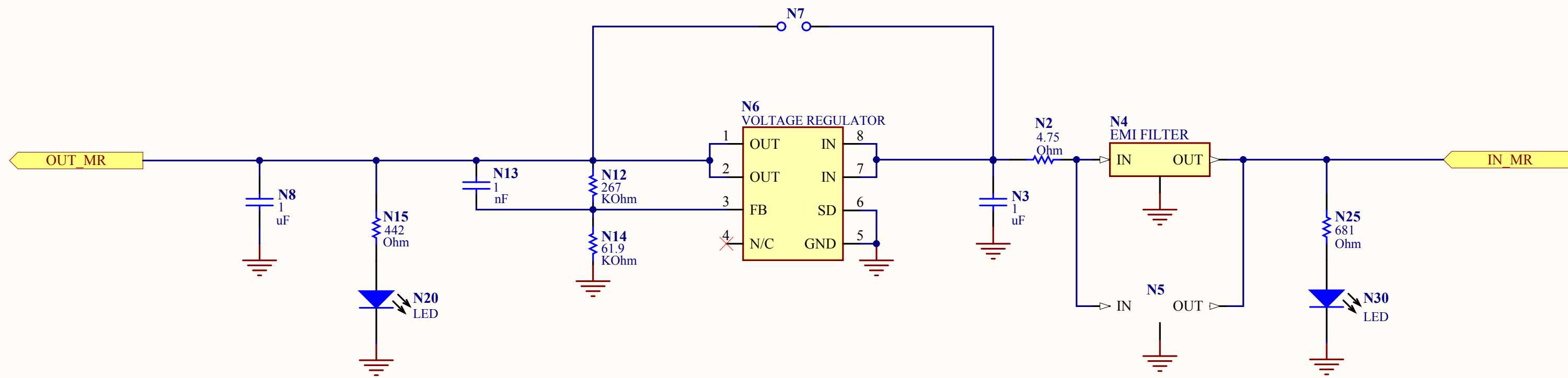

VCC PLL REGULATOR

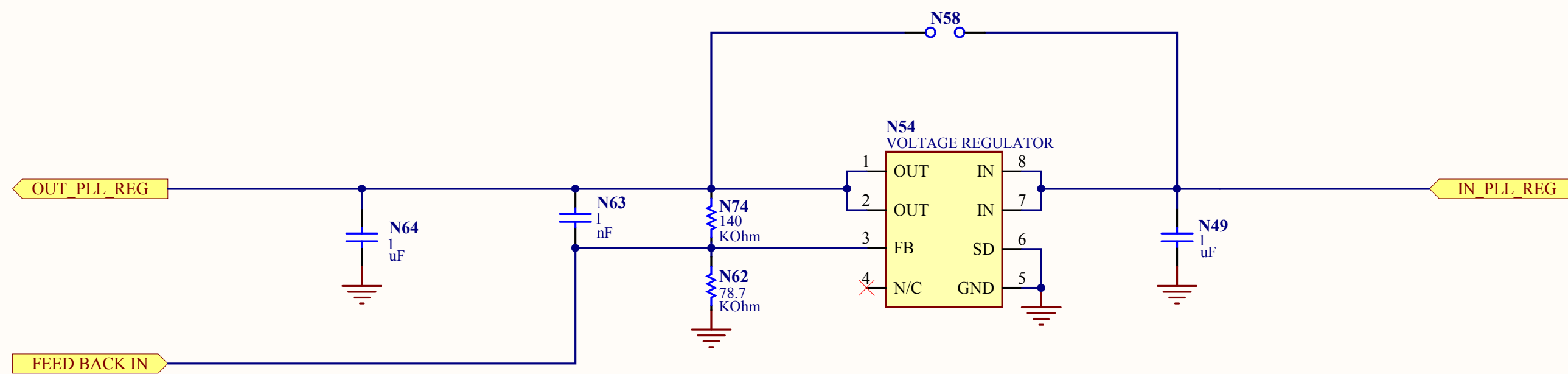

SCHMITT TRIGGER REGULATOR

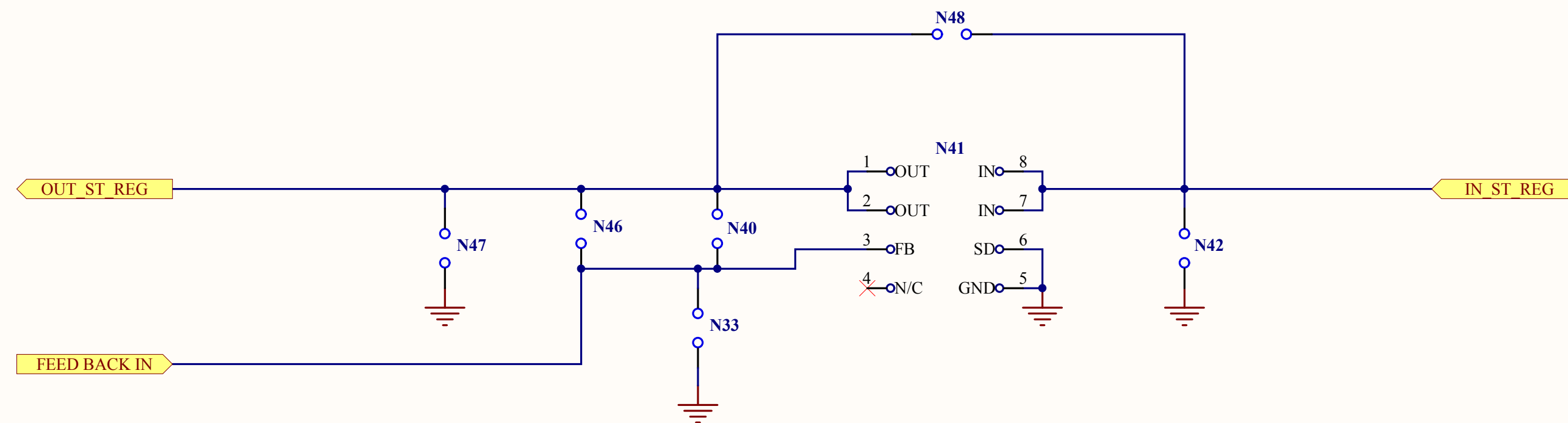

VCC VCO FILTERING

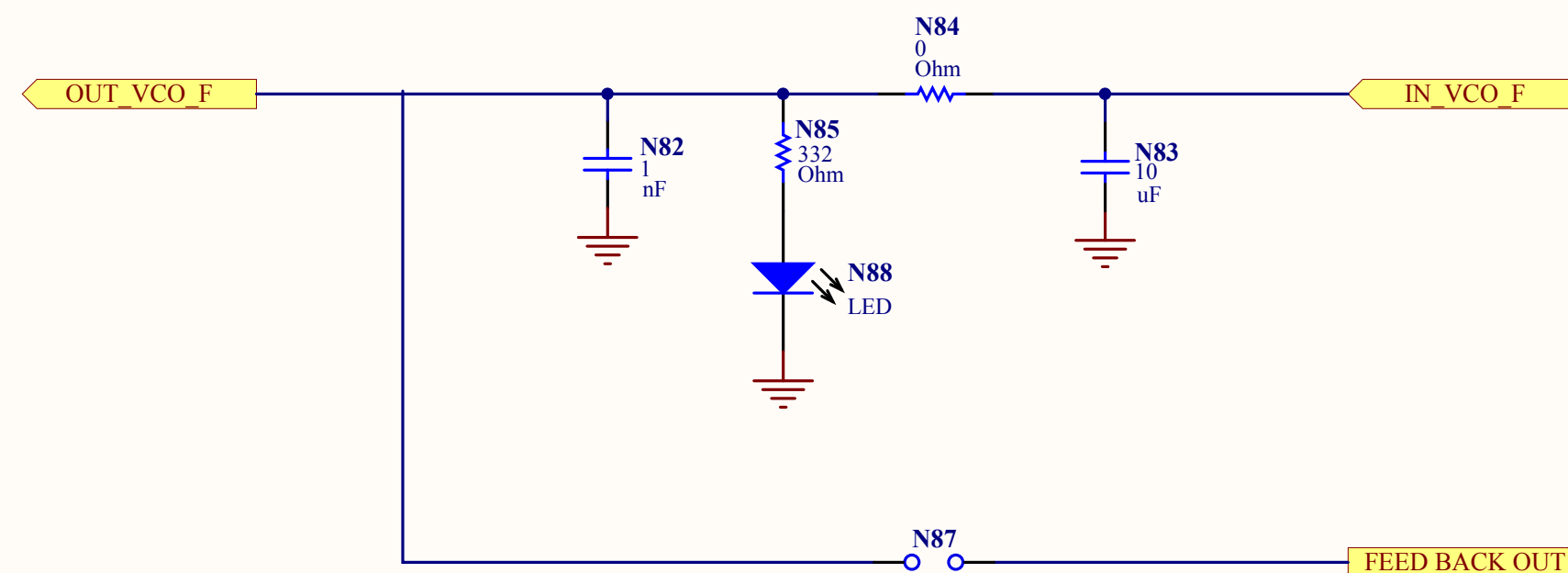

VCC PLL FILTERING

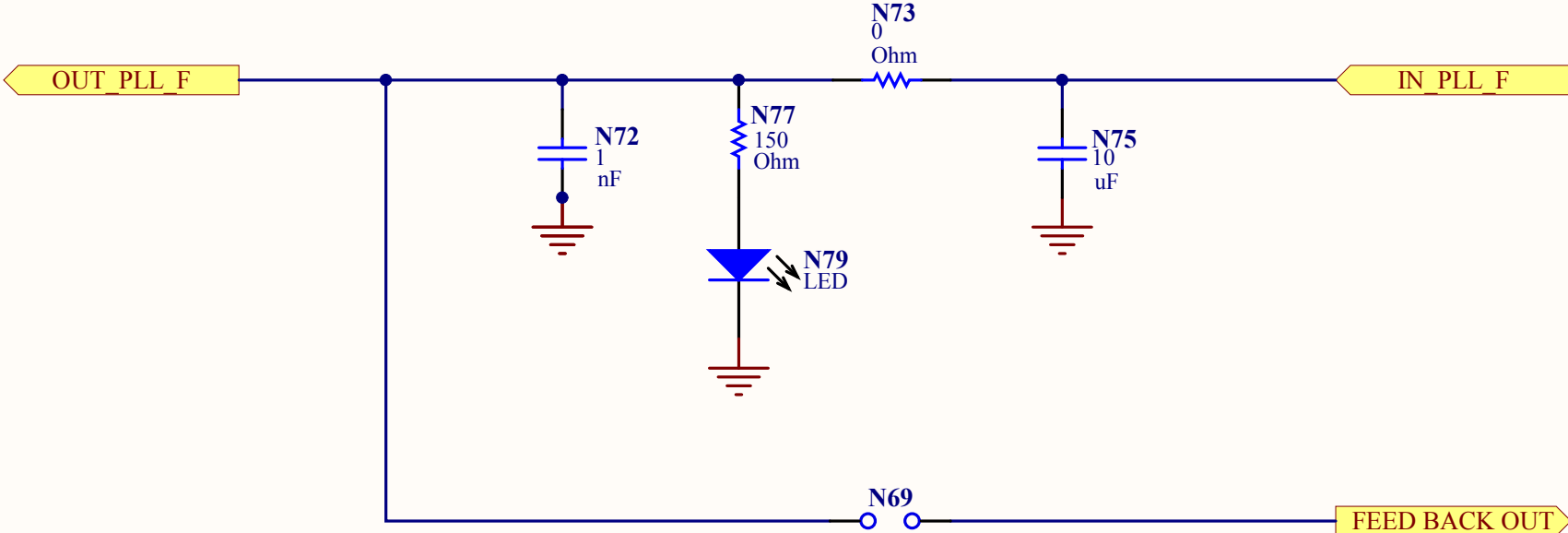

SCHMITT TRIGGER FILTERING

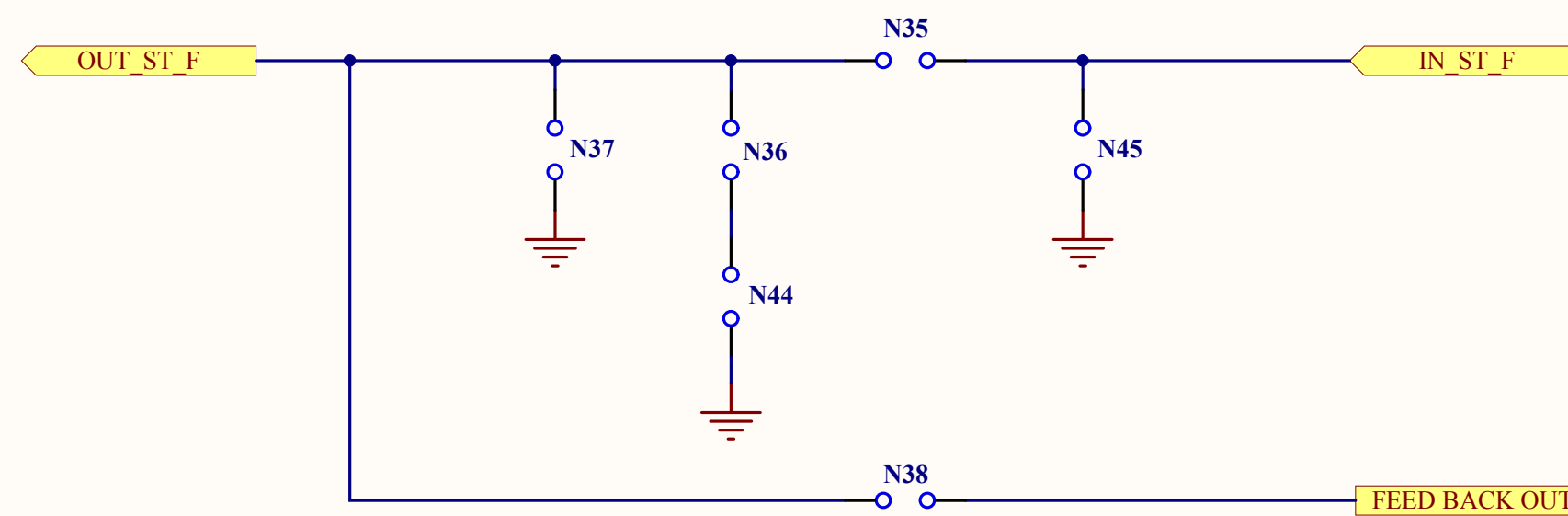

SCHMITT TRIGGER

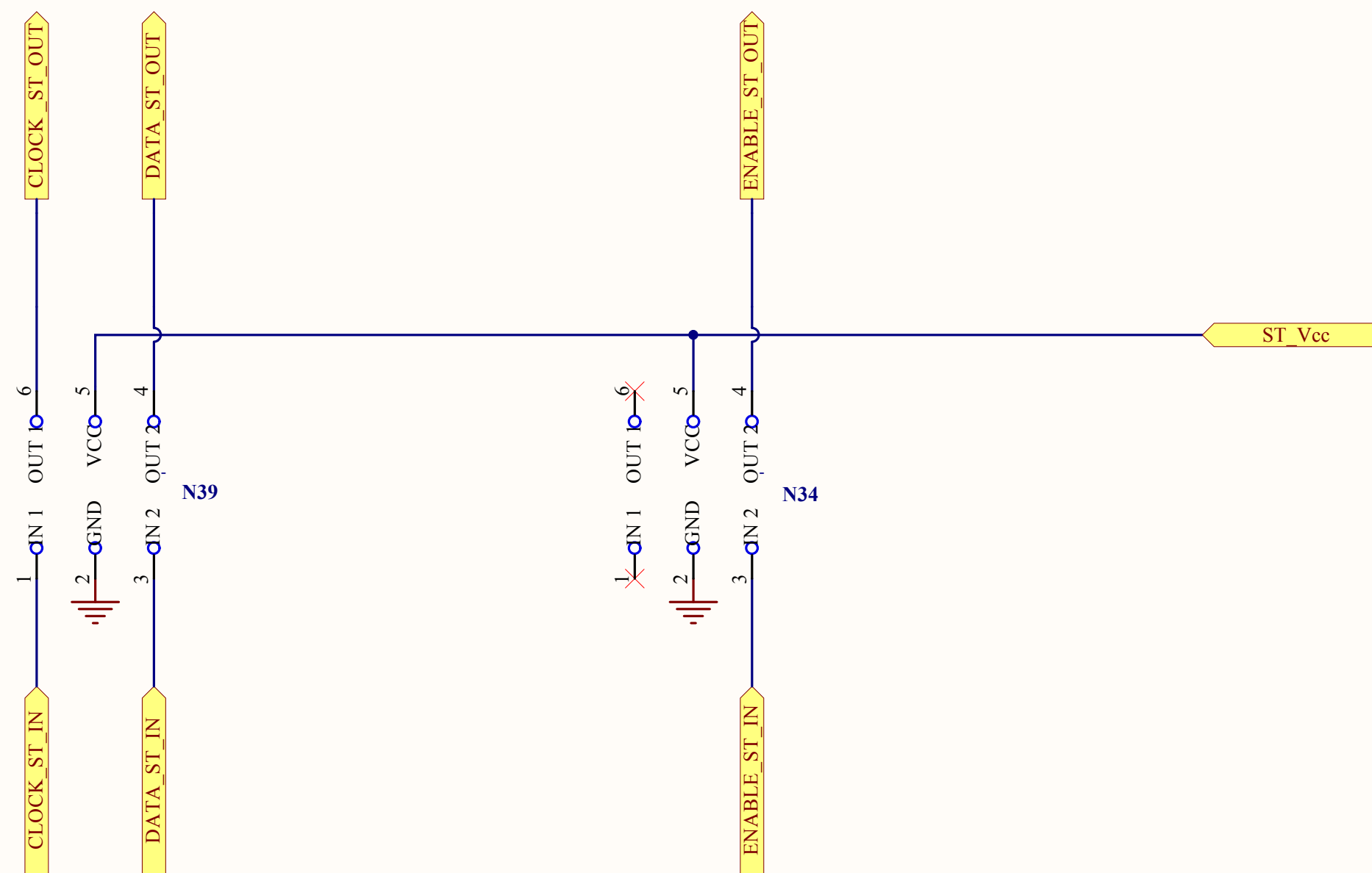

USB CONTROLER

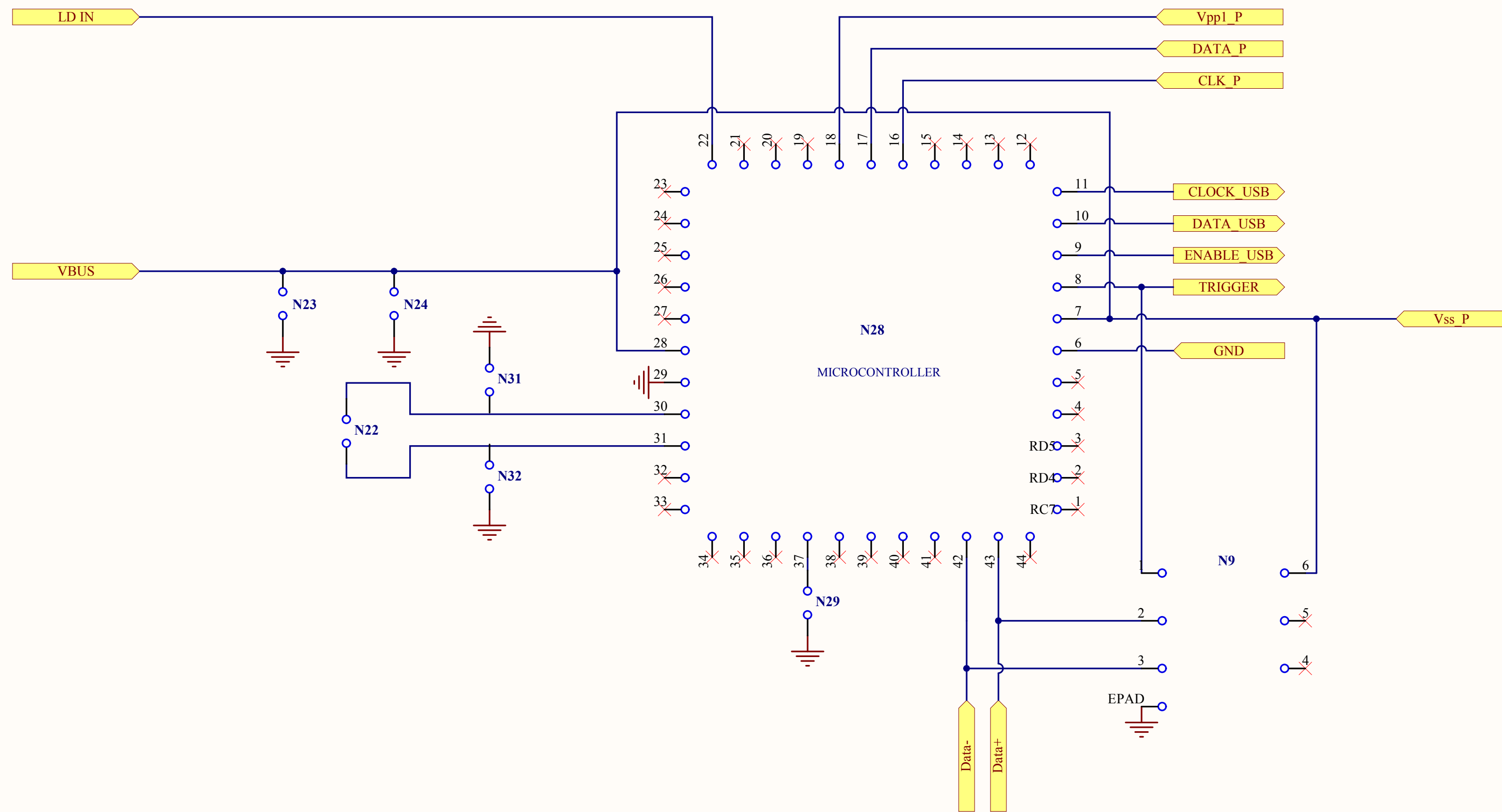

LD REGULATOR SCHMITT TRIGGER AND LED

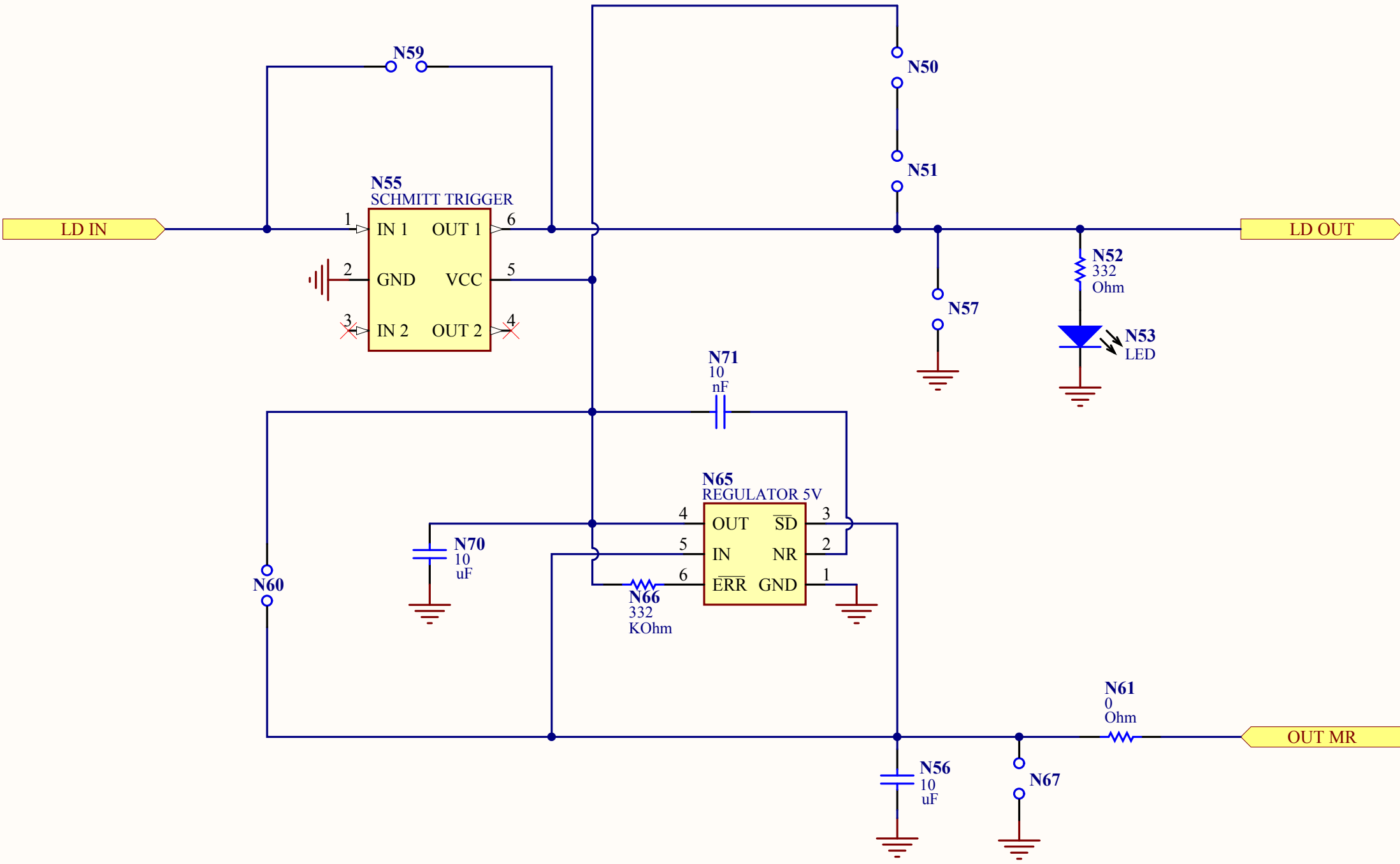

VCC VCO REGULATOR

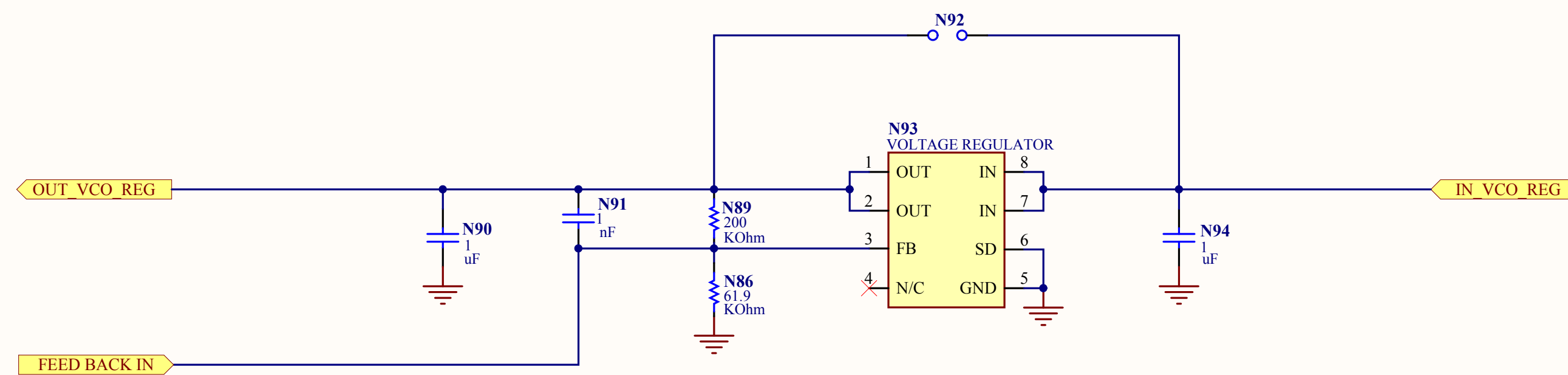

Evaluation Board and Circuit

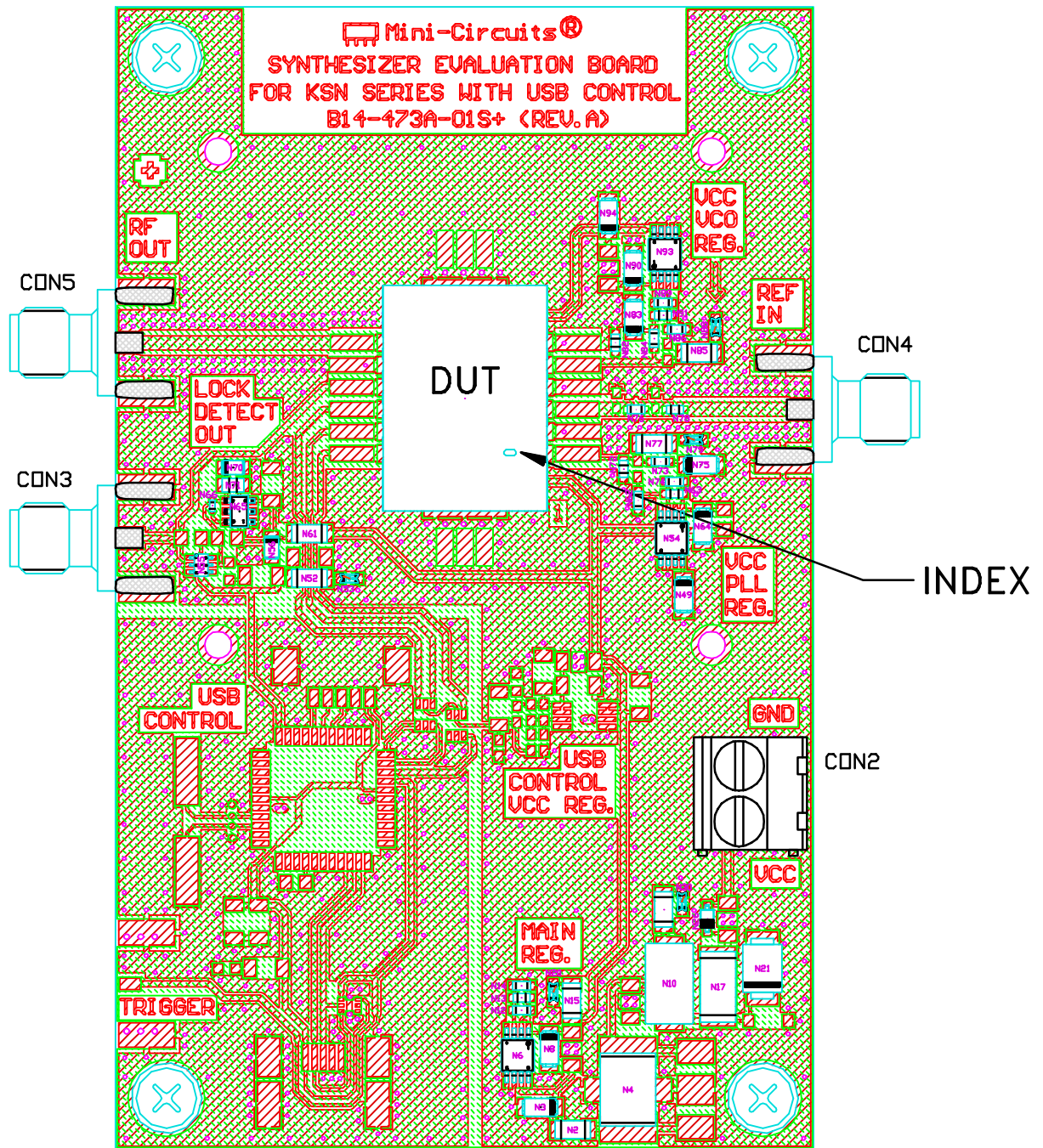

TB-567-1+F

N20,N30

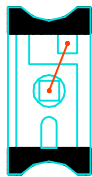

N88

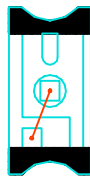

N53,N79

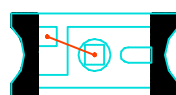

NOTES:

1. SMA F JACK CONNECTORS.
2. PCB MATERIAL: FR4 OR EQUIVALENT, DIALECTRIC CONSTANT=4.7, DIALECTRIC THICKNESS=.059 INCH.