

# Evaluation Board and Circuit

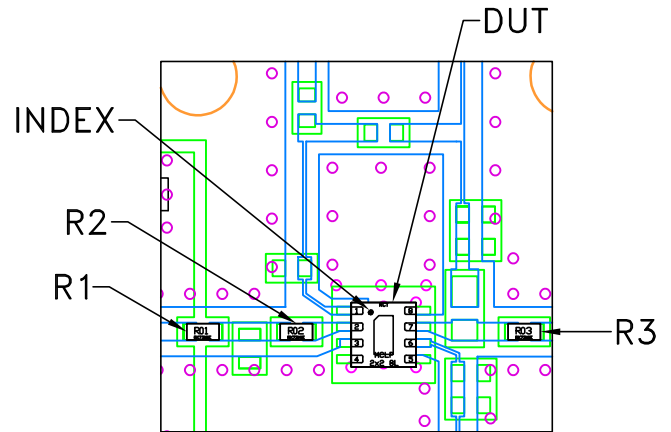

DETAIL "A"  
LOCATION OF COMPONENTS ON THE PCB  
(SCALE 3:1)

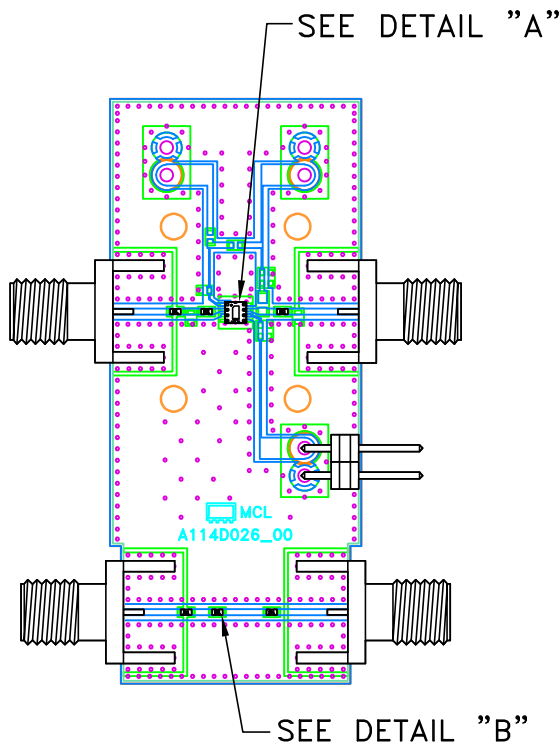
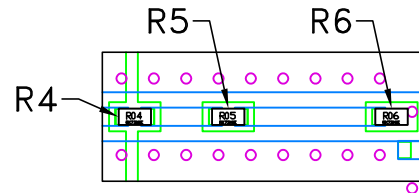

DETAIL "B"  
LOCATION OF COMPONENTS ON THE PCB  
(SCALE 3:1)

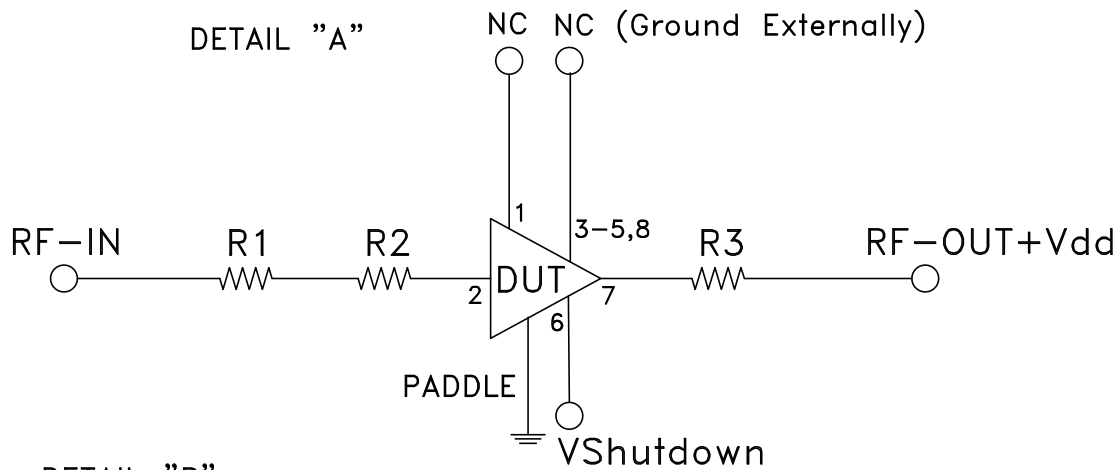

DETAIL "B"



THRU LINE  
SCHEMATIC DIAGRAM

Component	Size	Value	Part Number	Manufacturer
R1,R2,R3,R4,R5,R6	0402	00hm	RK73Z1ETTP	KOA Speer

## NOTES:

- 50 Ohm SMA Female Connectors.
- PCB Material: Roger R04350B or equivalent, Dielectric constant=3.5, Thickness=0.010 inch

 **Mini-Circuits®**