

Ceramic

RF Transformer

TCO1-462+

50Ω 3300 to 5900 MHz 1:1 Ratio

The Big Deal

- Tiny size, 0402
- Industry leading combination of size/bandwidth
- Good Power handling



CASE STYLE: NK0402C

Product Overview

Mini-Circuits' TCO1-462+ is a tiny ceramic RF balun transformer with an impedance ratio of 1:1, covering a variety of wireless communications applications from 3300 to 5900 MHz. This model provides low insertion loss, low phase unbalance (relative to 180°), low amplitude unbalance, and RF input power handling up to 2W. Fabricated using LTCC technology, the unit comes housed in a tiny, rugged ceramic package suitable for harsh operating environments.

Key Features

Feature	Advantages
2W power handling	Supports a wide range of power requirements
Tiny size, 0402	Accommodates tight space requirements for dense PCB layouts.
LTCC construction	LTCC process enables tiny size and low cost, suitable for high-volume production. Rugged ceramic package provides excellent reliability in harsh operating environments.
Wrap-around terminations	Provides excellent solderability and easy visual inspection

Ceramic

RF Transformer

50Ω 3300 to 5900 MHz 1:1 Ratio

TCO1-462+



Generic photo used for illustration purposes only

CASE STYLE: NK0402C

+RoHS Compliant

The +Suffix identifies RoHS Compliance. See our web site for RoHS Compliance methodologies and qualifications



Available Tape and Reel at no extra cost

Reel Size	Devices/Reel
7"	20, 50, 100, 200, 500, 1000, 4000

Features

- miniature size 0402 (0.039"[1.0mm] x 0.020"[0.5mm] x 0.015"[0.37mm])
- low insertion loss
- LTCC construction
- aqueous washable

Applications

- WLAN/Wi-Fi
- 5G sub 6 GHz
- LTE

Electrical Specifications at 25°C

Parameter	Frequency (MHz)	Min.	Typ.	Max.	Unit
Impedance Ratio			1		
Frequency Range		3300	—	5900	MHz
Insertion Loss ¹	3300 - 5900	—	0.8	—	dB
Amplitude Unbalance	3300 - 4200	—	1.7	—	dB
	4200 - 5900	—	0.7	—	dB
Phase Unbalance ²	3300 - 5900	—	10	—	Degree
Unbalance Return Loss	3300 - 5900	—	13	—	dB

1. Tested on Evaluation Board TB-TCO1-462+

2. Relative to 180°

Maximum Ratings

Parameter	Ratings
Operating Temperature	-55°C to 125°C
Storage Temperature*	-55°C to 125°C
RF Power**	2W at 25°C

Permanent damage may occur if any of these limits are exceeded.

* Refer to product storage temperature after installation.

Suggestion for T&R unused product storage condition: +5~+35°C, Humidity 45~75%RH, 12 Month max.

** Derate linearly to 0.5W at 125°C.

Pad Connections

Function	Pad Number
PRIMARY DOT (Unbalanced Port)	1
PRIMARY (GND)	4
SECONDARY DOT (Balanced)	2
SECONDARY (Balanced)	3

Configuration G

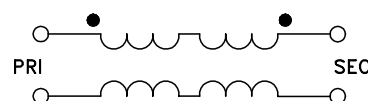

TCO1-462+

Outline Drawing

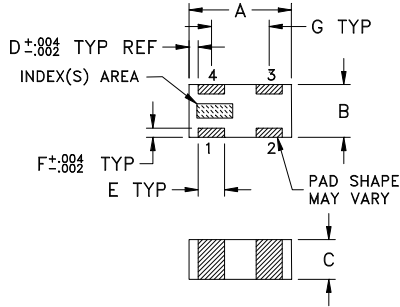

Outline Dimensions (inch/mm)

A	B	C	D	E	F	G	wt
.039	.020	.015	.004	.010	.004	.022	grams
1.0	0.51	0.38	0.10	0.25	0.10	0.56	.0007

Evaluation Board MCL P/N: TB-TCO1-462+ Suggested PCB Layout (PL-624)

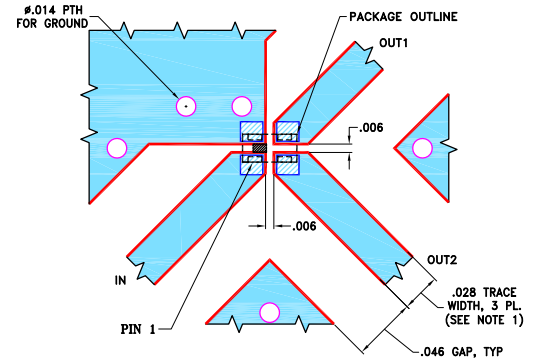

- NOTES:**
- TRACE WIDTH & GAP ARE SHOWN FOR FR4, GRADE IT-180TC (ITEQ CORP.) WITH DIELECTRIC THICKNESS .016±.0015. COPPER: 1/2 OZ. EACH SIDE. FOR OTHER MATERIALS TRACE WIDTH & GAP MAY NEED TO BE MODIFIED.
 - BOTTOM SIDE OF THE PCB IS CONTINUOUS GROUND PLANE.
- DENOTES PCB COPPER LAYOUT WITH SMOBC (SOLDER MASK OVER BARE COPPER).
 ■ DENOTES COPPER LAND PATTERN FREE OF SOLDER MASK.

Typical Performance Data³

Frequency (MHz)	Insertion Loss (dB)	Input R. Loss (dB)	Amplitude Unbalance (dB)	Phase Unbalance (Deg.)
3300	0.58	19.87	1.72	0.09
4750	0.52	16.14	0.05	0.51
4900	0.46	15.69	0.05	1.07
5000	0.44	15.57	0.12	1.55
5200	0.46	15.61	0.25	2.60
5350	0.51	15.73	0.34	3.58
5500	0.56	15.75	0.42	4.55
5650	0.61	15.71	0.44	5.75
5700	0.58	15.91	0.49	6.10
5800	0.56	16.10	0.49	6.90
5900	0.51	16.50	0.49	7.60

3. Measured with Agilent N5242A network analyzer using impedance conversion and port extension.

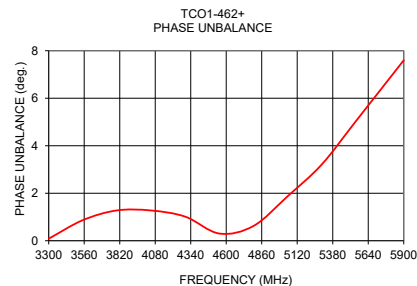
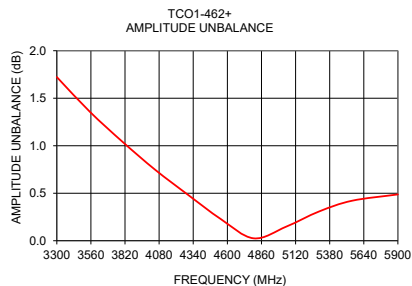
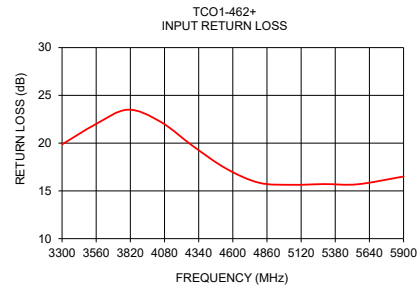
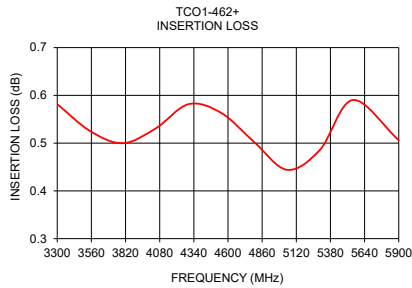

Additional Notes

- Performance and quality attributes and conditions not expressly stated in this specification document are intended to be excluded and do not form a part of this specification document.
- Electrical specifications and performance data contained in this specification document are based on Mini-Circuits' applicable established test performance criteria and measurement instructions.
- The parts covered by this specification document are subject to Mini-Circuits standard limited warranty and terms and conditions (collectively, "Standard Terms"); Purchasers of this part are entitled to the rights and benefits contained therein. For a full statement of the Standard Terms and the exclusive rights and remedies thereunder, please visit Mini-Circuits' website at www.minicircuits.com/MCLStore/terms.jsp



Typical Performance Data

FREQUENCY (MHz)	AVERAGE INSERTION LOSS (dB)	INPUT RETURN LOSS (dB)	AMPLITUDE UNBALANCE (dB)	PHASE UNBALANCE ⁽¹⁾ (deg.)
3000	0.63	18.34	2.17	1.91
3050	0.63	18.53	2.09	1.55
3100	0.62	18.72	2.02	1.22
3150	0.61	18.96	1.94	0.92
3200	0.60	19.23	1.87	0.65
3250	0.59	19.56	1.79	0.34
3300	0.58	19.87	1.72	0.09
3350	0.57	20.29	1.64	0.16
3400	0.56	20.61	1.58	0.36
3450	0.55	21.10	1.50	0.57
3500	0.54	21.53	1.43	0.71
3550	0.53	21.93	1.36	0.87
3600	0.52	22.37	1.30	0.95
3650	0.51	22.73	1.22	1.08
3700	0.51	23.10	1.17	1.17
3750	0.50	23.21	1.10	1.24
3800	0.50	23.50	1.04	1.28
3850	0.50	23.31	0.97	1.30
3900	0.50	23.42	0.92	1.34
3950	0.52	22.89	0.86	1.31
4000	0.52	22.82	0.81	1.35
4050	0.53	22.23	0.75	1.27
4100	0.54	21.90	0.69	1.31
4150	0.55	21.29	0.64	1.22
4200	0.56	20.80	0.59	1.18
4250	0.56	20.23	0.54	1.07
4300	0.58	19.65	0.48	1.01
4350	0.57	19.16	0.43	0.90
4400	0.59	18.57	0.38	0.78
4450	0.57	18.22	0.33	0.62
4500	0.59	17.66	0.28	0.48
4550	0.56	17.33	0.23	0.30
4600	0.57	16.88	0.20	0.14
4650	0.55	16.63	0.14	0.11
4700	0.54	16.29	0.11	0.21
4750	0.52	16.14	0.05	0.51
4800	0.50	15.85	0.03	0.62
4850	0.48	15.81	0.02	0.98
4900	0.46	15.69	0.05	1.07
4950	0.46	15.69	0.09	1.40
5000	0.44	15.57	0.12	1.55
5050	0.44	15.64	0.15	1.87
5100	0.44	15.59	0.19	2.07
5150	0.45	15.67	0.22	2.35
5200	0.46	15.61	0.25	2.60
5250	0.47	15.70	0.28	2.93
5300	0.49	15.71	0.31	3.21
5350	0.51	15.73	0.34	3.58
5400	0.52	15.75	0.37	3.86
5450	0.55	15.71	0.39	4.34
5500	0.56	15.75	0.42	4.55
5550	0.59	15.69	0.42	5.04
5600	0.58	15.78	0.46	5.30
5650	0.61	15.71	0.44	5.75
5700	0.58	15.91	0.49	6.10
5750	0.59	15.90	0.44	6.37
5800	0.56	16.10	0.49	6.90
5850	0.54	16.19	0.44	6.96
5900	0.51	16.50	0.49	7.60
5950	0.47	16.65	0.46	7.50
6000	0.43	16.97	0.48	8.17

⁽¹⁾ Relative to 180°

Typical Performance Data

Average Insertion Loss

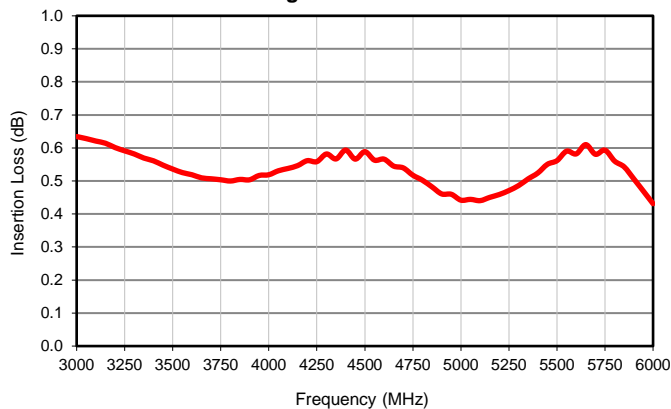

Input Return Loss

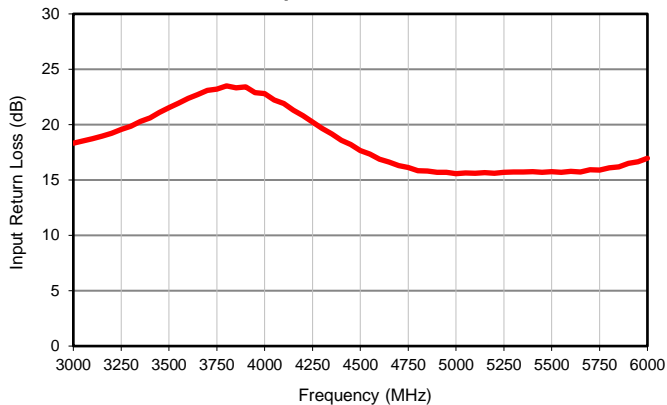

Amplitude Unbalance

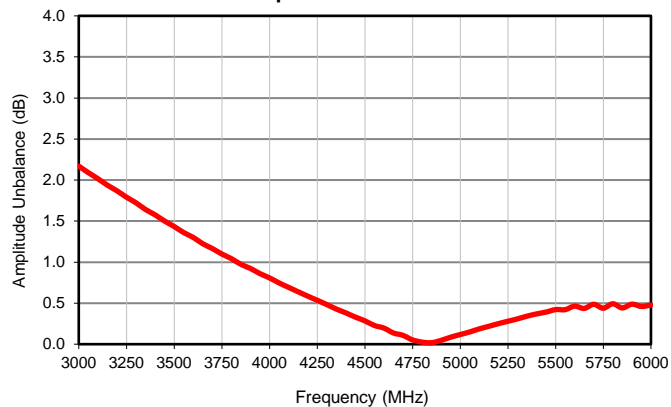

Phase Unbalance

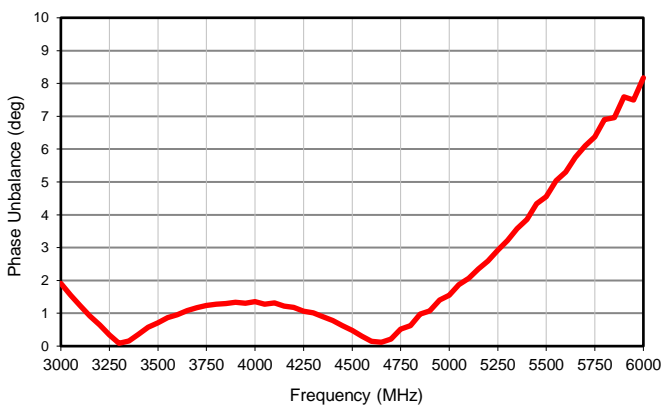

Outline Dimensions

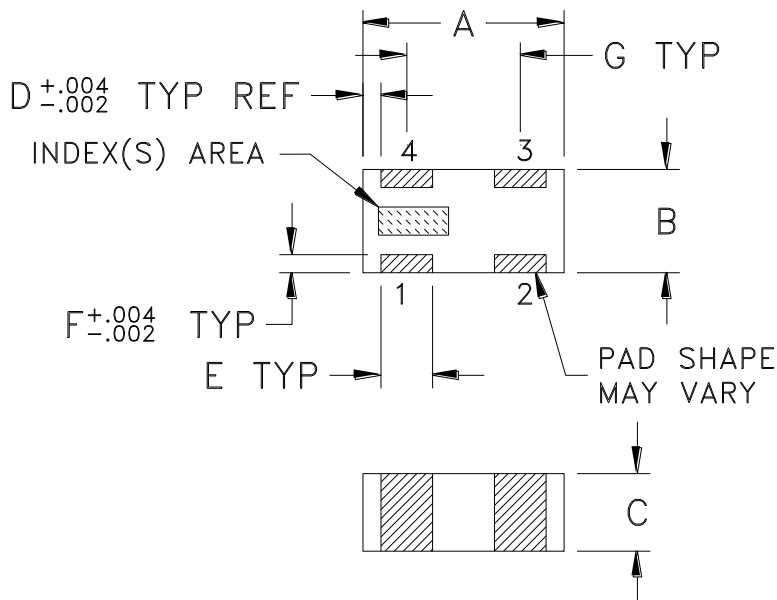

PCB Land Pattern

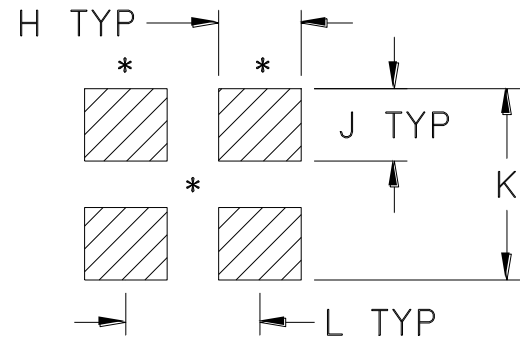

Suggested Layout,
Tolerance to be within $\pm .002$

CASE#	A	B	C	D	E	F	G	H	J	K	L	WT.GRAMS
NK0402C	.039 (1.00)	.020 (.50)	.015 (0.37)	.004 (0.10)	.010 (0.25)	.004 (0.10)	.022 (0.55)	.016 (0.41)	.014 (0.36)	.037 (0.94)	.026 (0.65)	.0007

Dimensions are in inches (mm). Tolerances: 2 Pl. $\pm .01$; 3 Pl. $\pm .005$

Notes:

1. Open style, ceramic base.
2. Termination finish:
For RoHS Case Styles: Matte Tin over Nickel plating. Models with (+) suffix.
3. *Line width should be designed to match 50 Ω characteristic impedance, depending on PCB material and thickness.



P.O. Box 350166, Brooklyn, New York 11235-0003 (718) 934-4500 Fax (718) 332-4661 For detailed performance specs & shopping online see Mini-Circuits web site



The Design Engineers Search Engine Provides ACTUAL Data Instantly From MINI-CIRCUITS At: www.minicircuits.com

RF/IF MICROWAVE COMPONENTS

THIRD ANGLE PROJECTION

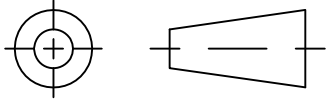

REVISIONS

REV	ECN No.	DESCRIPTION	DATE	DR	AUTH
OR	M173420	NEW RELEASE	03/26/19	ITG	SL

SUGGESTED MOUNTING CONFIGURATION
FOR NK0402C CASE STYLE, "04TG01" PIN CODE

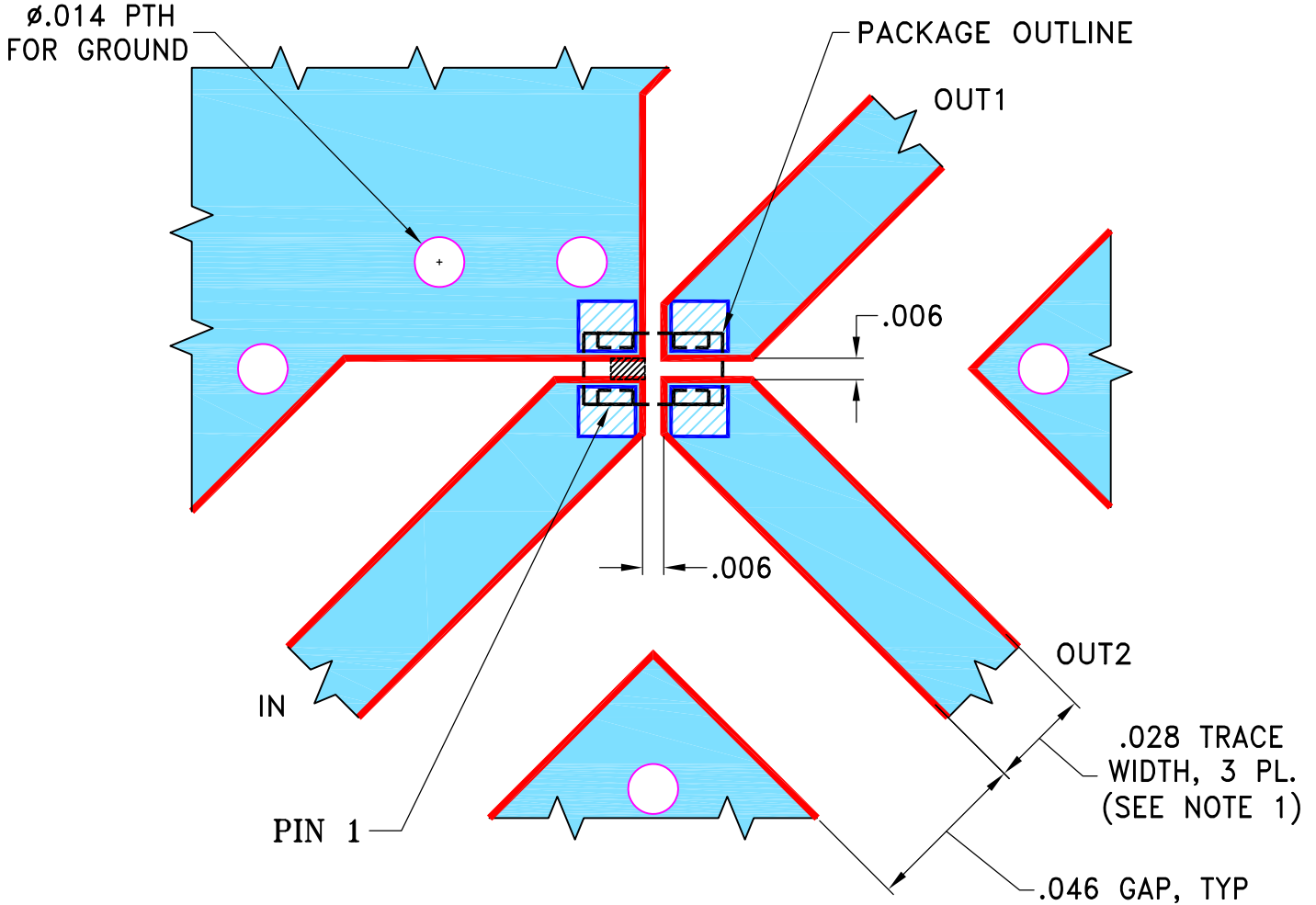

NOTES:

- TRACE WIDTH & GAP ARE SHOWN FOR FR4, GRADE IT-180TC (ITEQ CORP.) WITH DIELECTRIC THICKNESS $.016 \pm .0015$. COPPER: 1/2 OZ. EACH SIDE. FOR OTHER MATERIALS TRACE WIDTH & GAP MAY NEED TO BE MODIFIED.
- BOTTOM SIDE OF THE PCB IS CONTINUOUS GROUND PLANE.



DENOTES PCB COPPER LAYOUT WITH SMOBC (SOLDER MASK OVER BARE COPPER).

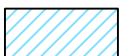

DENOTES COPPER LAND PATTERN FREE OF SOLDER MASK.

UNLESS OTHERWISE SPECIFIED	INITIALS	DATE
DIMENSIONS ARE IN INCHES TOLERANCES ON: 2 PL DECIMALS ± 3 PL DECIMALS ± .005 ANGLES ± FRACTIONS ±	DRAWN	ITG 03/22/19
	CHECKED	GF 03/22/19
	APPROVED	SL 03/26/19



Mini-Circuits®

13 Neptune Avenue
Brooklyn NY 11235

PL, 04TG01, NK0402C, TB-1012-X542+

SIZE A	CODE IDENT 15542	DRAWING NO: 98-PL-624	REV: OR
FILE: 98PL624	SCALE: 20:1	SHEET: 1 OF 1	

Mini-Circuits®
THIS DOCUMENT AND ITS CONTENTS ARE THE PROPERTY OF MINI-CIRCUITS. EXCEPT FOR USE EXPRESSLY GRANTED, IN WRITING, TO ITS VENDORS, VENDEE AND THE UNITED STATES GOVERNMENT, MINI-CIRCUITS RESERVES ALL PROPRIETARY DESIGN, USE, MANUFACTURING AND REPRODUCTION RIGHTS THERETO. THESE CONTENTS SHALL NOT BE USED, DUPLICATED OR DISCLOSED TO ANY OUTSIDE PARTY, IN WHOLE OR IN PART, WITHOUT WRITTEN PERMISSION OF MINI-CIRCUITS.

Evaluation Board and Circuit

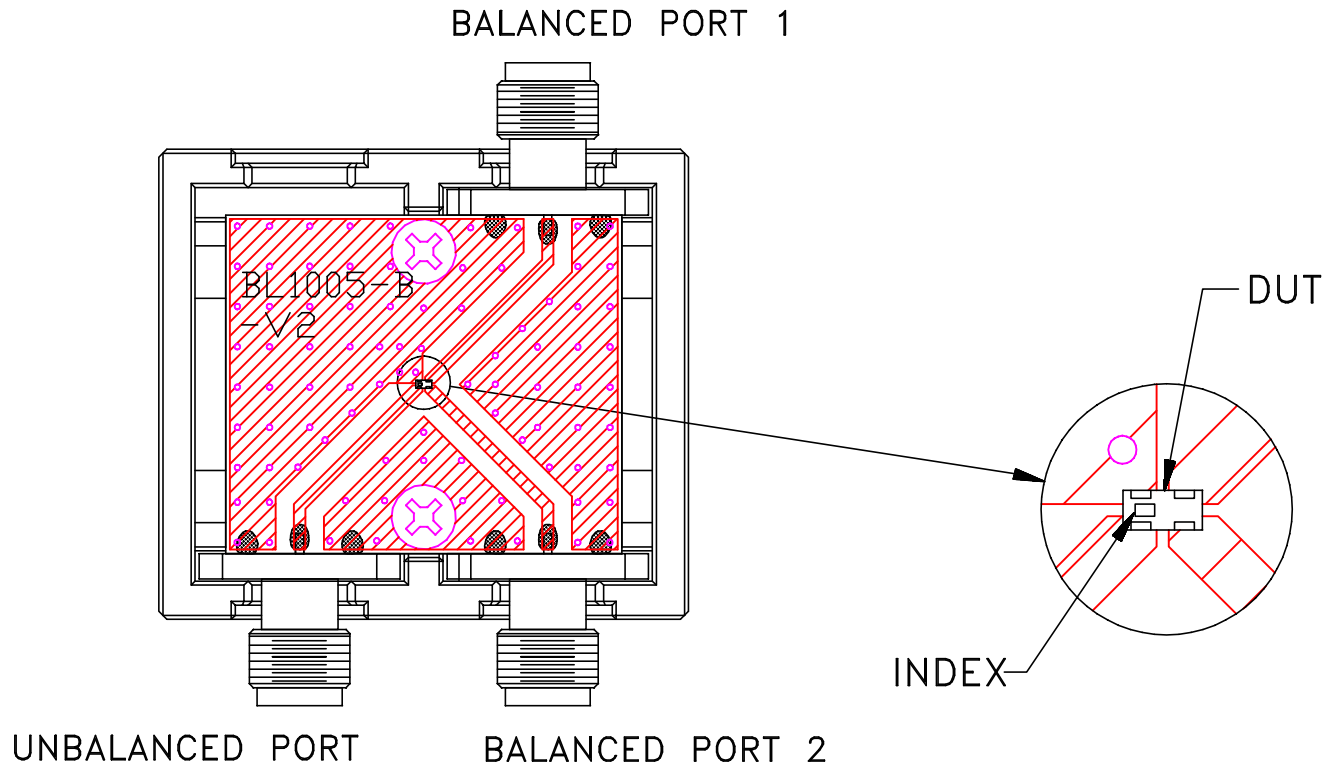

TB-1012-1542+

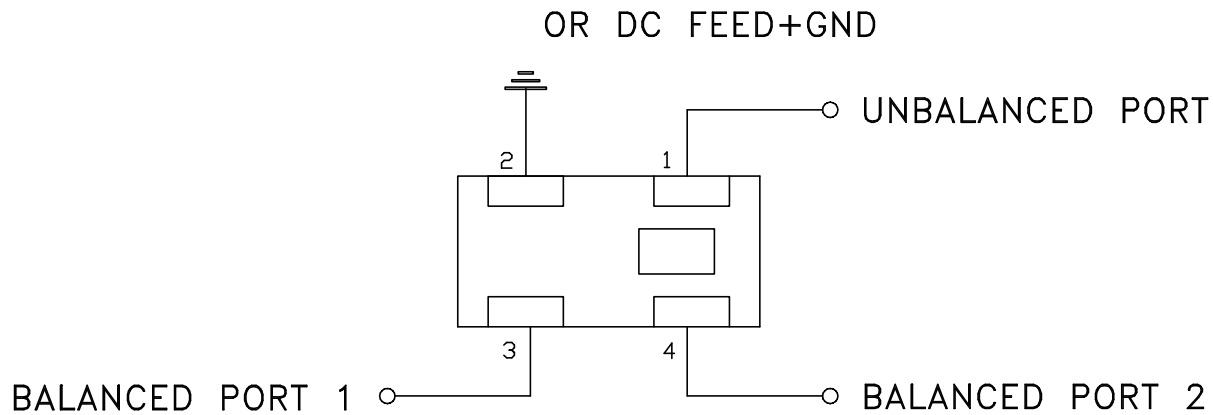

Schematic Diagram

Notes:

1. 50 Ohm SMA Female connectors.
2. PCB Material: FR4 or equivalent,
Dielectric Constant=4.5, Thickness=.016 inch.

 **Mini-Circuits®**

All Mini-Circuits products are manufactured under exacting quality assurance and control standards, and are capable of meeting published specifications after being subjected to any or all of the following physical and environmental test.

Specification	Test/Inspection Condition	Reference/Spec
Operating Temperature	-55° to 125° C Ambient Environment	Individual Model Data Sheet
Storage Temperature	-55° to 125° C Ambient Environment	Individual Model Data Sheet
Humidity	90 to 95% RH, 240 hours, 50°C	MIL-STD-202, Method 103, Condition A, Except 50°C and end-point electrical test done within 12 hours
Solder Reflow Heat	Sn-Pb Eutectic Process: 225°C peak Pb-Free Process: 250°C peak	J-STD-020C, Table 4-1, 4-2 and 5-2; Figure 5-1
Solderability	10X Magnification	J-STD-002, Para 4.2.5, Test S, 95% Coverage
Vibration (High Frequency)	20g peak, 10-2000 Hz, 12 times in each of three perpendicular directions (total 36)	MIL-STD-202, Method 204, Condition D
Mechanical Shock	50g, 11 ms, 1/2-sine, 18 shocks: 3 each direction, each of 3 axes	MIL-STD-202, Method 213, Condition A